



Supermarine Spitfire Mk.XVI

Die Supermarine Spitfire Mk.XVI war äußerlich mit der Spitfire Mk.IX identisch, sie unterschied sich von ihr nur durch den verwendeten Motortyp: die Mk.IX wurde von einem Rolls Royce 66 oder 70-Motor angetrieben, die Mk. XVI von einem 1.705 PS starken Merlin 266-Motor, der von American Packard in Lizenz gebaut wurde. Die Produktion startete im September 1944, das erste Flugzeug wurde im Januar 1945 an die No. 443 Squadron der Royal Canadian Air Force ausgeliefert. Alle 1.054 Maschinen wurden im riesigen Werk von Castle Bromwich bei Birmingham in England gebaut. Die letzte Auslieferung fand im August 1945 statt. Die Version war für Tiefflug-Einsätze als Jagdbomber optimiert worden und hatte die typischen „E-Flügel“ mit langläufigen 20mm-Kanonen außenbords der Maschinenengewehre des Kalibers 12,7mm. Mit Spitfire Mk.XVI wurden 36 Squadrons der Royal Air Force ausgerüstet, einschließlich acht Squadrons der Royal Auxiliary Air Force nach dem Krieg. Die Flugzeuge waren bis 1951 im Dienst, bis sie von den strahlgetriebenen Flugzeugtypen Vampire und Meteor ersetzt wurden. Die SL718 der No. 612 Squadron der Royal Auxiliary Air Force war eine von mehreren Spitfire-Flugzeugen, die nach dem Krieg an Luftrennen im Vereinigten Königreich teilnahmen. Maschinen der Version Mk.XVI wurden auch an die Luftstreitkräfte Frankreichs, Belgiens und Burmas geliefert. Im Jahr 2012 gibt es von der Spitfire Mk.XVI noch fünf flugtüchtige bzw. in Restaurierung befindliche Exemplare, die wieder für den Flugeinsatz flott gemacht werden sollen; etliche weitere sind in Museen rund um den Erdball ausgestellt. Mit dem Merlin 266-Motor erreichte sie eine Höchstgeschwindigkeit von 652km/h (405 mph) auf einer Höhe von 6.705m (22.000ft). Die maximale Reichweite betrug 1.577km (980 Meilen). Spannweite: 9,93m (32ft 7 in.), Länge 9,55m (31ft 4 in.).

Supermarine Spitfire Mk.XVI

The Supermarine Spitfire Mk.XVI was externally identical to the Spitfire Mk.IX, differing only by the type of Merlin engine fitted - the Mk.IX having a Rolls-Royce 66 or 70 powerplant and the Mk.XVI used the American Packard licence-built 1,705hp Merlin 266 engine. Production commenced in September 1944 with the first aircraft reaching No.443 Sqn. Royal Canadian Air Force in January 1945. All 1054 aircraft were built at the huge Castle Bromwich factory near Birmingham, with the last delivery taking place in August 1945. Optimised for low-level fighter-bomber role, this version was typically fitted with the 'E' wing having the long 20mm cannon barrels outboard of the 0.5in machine guns. Spitfire Mk.XVIs equipped 36 RAF squadrons, including eight squadrons of the Royal Auxiliary Air Force after the war, these serving until 1951 when they were replaced by jet powered Vampires and Meteors. SL718 of No.612 Sqn, Royal Auxiliary Air Force, was one of several Spitfires entered in post war UK air races. Mk.XVIs were also supplied to the air forces of France, Belgium and Burma. In 2012, five Spitfire Mk.XVIs are airworthy or being restored to flying condition, with several others displayed in museums around the world. The Merlin 266 engine gave a maximum speed of 652km/h (405mph) at 6,705m (22,000ft). Maximum range was 1,577km (980 miles). Wingspan: 9.93m (32ft 7in.) Length: 9.55m (31ft 4in.)

Benötigte Farben / Used Colors

Benötigte Farben
Required colours

Peintures nécessaires
Benodigde kleuren

Pinturas necesarias
Tintas necessárias

Colori necessari
Använda färger

Tarvittavat värit
Du trenger følgende farger

Nødvendige farger
Необходимые краски

Potrzebne kolory
Απαιτούμενα χρώματα

Gerekli renkler
Potřebné barvy

Szükséges színek.
Potrebne barve

A

Dunkelgrün, matt 68
Dark green, matt
Vert foncé, mat
Donkergroen, mat
Verde oscuro, mate
Verde oscuro, opaco
Mörkgrön, matt
Tummanvihreä, matta
Mörkgrön, mat
Mörkgrønn, matt
Темно-зеленый, матовый
Ciemnozielony, matowy
Πράσινο σκούρο, ματ
Koyu yeşil, mat
Sötétzöld, matt
Tmavozelená, matná
Temnozelená, brez leska

B

staubgrau, matt 77
dust grey, matt
gris poussière, mat
stolgrijs, mat
cincento, mate
cinzento de pó, fosco
Verde scuro, opaco
dammgrå, matt
pölyharmaa, himmeä
stovgrå, mat
stovgrå, matt
Серый пыльный, матовый
szary kurz, matowy
χρώμα σκόνης, ματ
toz grisi, mat
prachová šedá, matná
porszürke, matt
prah siva, mat

C

Mittelgrau, matt 43
Medium grey, matt
Gris moyen, mat
Middelgrijs, mat
Gris medio, mate
Cinzento-médio, mate
grigio medio, opaco
Mellangrå, matt
Keskiharmaa, matta
Mellomgrå, mat
Mellomgrå, matt
Серый, матовый
Srednioszary, matowy
Γκρι μεσαίο, ματ
Orta gri, mat
Középszürke, matt
Sifedná šedivá, matná
Srednjesiva, brez leska

D

gelb, matt 15
yellow, matt
jaune, mat
geel, mat
amarillo, mate
amarlo, fosco
giallo, opaco
gul, mat
keltainen, himmeä
gul, mat
gul, mat
желтый, матовый
žółty, matowy
κιτρινο, ματ
sari, mat
žlutá, matná
sárga, matt
rumena, mat

E

schwarz, matt 8
black, matt
noir, mat
zwart, mat
negro, mate
preto, fosco
nero, opaco
svart, matt
musta, himmeä
sort, mat
sort, matt
черный, матовый
czarny, matowy
μαύρο, ματ
siyah, mat
černá, matná
fekete, matná
črna, mat

25 % **F** 75 %

eisen, metallic 91
steel, metallic
coloris fer, métallique
ijzerkleurig, metallic
ferroso, metalizado
ferro, metálico
ferro, metallico
järnfärg, metallic
teräksenvärinen, metallikiilto
jern, metallak
jern, metallic
стальной, металл
żelazo, metaliczny
σιδηρού, μεταλλικό
demir, metalik
železná, metaliza
vas, metáll
železná, metalik

rost, matt 83
rust, matt
rouille, mat
roest, mat
orin, mate
ferrugem, fosco
color ruggine, opaco
rost, matt
ruoste, himmeä
rust, mat
rust, matt
ржавчина, матовый
rdzawy, matowy
χρώμα σκουριάς, ματ
pas rengi, mat
rezavá, matná
rozsa, matt
rjava, mat

G

anthrazit, matt 9
anthracite grey, matt
anthracite, mat
antraciet, mat
antracita, mate
antracite, fosco
antracite, opaco
antracit, matt
antrasiti, himmeä
koksgrå, mat
antrasit, matt
антрацит, матовый
antracyt, matowy
ανθρακι, ματ
antrasit, mat
antracit, matná
antracit, matt
tamno siva, mat

H

feuerrot, seidenmatt 330
fiery red, silky-matt
rouge feu, satiné mat
rood heider, zijdemat
rojo fuego, mate seda
vermelho vivo, fosco sedoso
rosso fuoco, opaco seta
elirdó, sidenmatt
tulipunainen, silkkihimmeä
idrórd, silkenat
idrórd, silkenat
огненно-красный, шелк.-матовый
szczerwony ognisty, jedwabisto-mat.
κόκκινο φωτιάς, μεταξωτό ματ
ateş kırmızı, ipek mat
ohnivě červená, hedvábně matná
tűzpiros, selyemmatt
ogey rdéca, svila mat

I

laubgrün, seidenmatt 364
leaf green, silky-matt
vert feuille, satiné mat
bladgroen, zijdemat
verde foliage, mate seda
verde gaio, fosco sedoso
verde foglia, opaco seta
lövgroen, sidenmatt
lehdenvihreä, silkkihimmeä
lövgrön, silkenat
lövgrön, silkenat
лиственно-зеленый, шелк.-матовый
zielony liściasty, jedwabisto-matowy
πράσινο φυλλωμάτων, μεταξ. ματ
yaprak yeşili, ipek mat
zelená jako listí, hedvábně matná
lombzöld, selyemmatt
list zelena, svila mat

J

eisen, metallic 91
steel, metallic
coloris fer, métallique
ijzerkleurig, metallic
ferroso, metalizado
ferro, metálico
ferro, metallico
järnfärg, metallic
teräksenvärinen, metallikiilto
jern, metallak
jern, metallic
стальной, металл
żelazo, metaliczny
σιδηρού, μεταλλικό
demir, metalik
železná, metaliza
vas, metáll
železná, metalik

30 %

gelb, matt 15
yellow, matt
jaune, mat
geel, mat
amarillo, mate
amarlo, fosco
giallo, opaco
gul, mat
keltainen, himmeä
gul, mat
gul, mat
желтый, матовый
žółty, matowy
κιτρινο, ματ
sari, mat
žlutá, matná
sárga, matt
rumena, mat

40 %

seegrün, matt 48
sea green, matt
vert d'eau, mat
zeegroen, mat
verde mar, mate
verde-mar, fosco
verde lago, opaco
havsgrön, matt
merenvihreä, himmeä
havgrön, mat
sjøgrønn, matt
зеленый морской, матовый
zielefi morska, matowy
πράσινο λιμνής, ματ
göl yeşili, mat
mořská zelená, matná
tengerzöld, matt
morsko zelena, mat

K

30 %

hellgrau, matt 76
Light grey, matt
Gris clair, mat
Lichtgrijs, mat
Gris claro, mate
Cinzento-chiaro, mate
Grigio chiaro, opaco
Ljusgrå, matt
Vaaleanharmaa, matta
Lysegrå, mat
Lysgrå, matt
Светло-серый, матовый
Jasnoszary, matowy
Γκρι ανοιχτό, ματ
Açık gri, mat
Világosszürke, matt
Svetle šedivá, matná
Svetlosiva, brez leska

L

aluminium, metallic 99
aluminium, metallic
aluminium, métallique
aluminium, metallic
aluminio, metalizado
aluminio, metálico
aluminio, metallico
aluminium, metallic
aluminium, metallikiilto
aluminium, metallak
aluminium, metallic
алюминиевый, металл
aluminium, metaliczny
αλουμινίου, μεταλλικό
aluminium, metalik
hlíniková, metaliza
aluminium, metáll
aluminium, metalik

M

lederbraun, matt 84
leather brown, matt
brun cuir, mat
lederbruin, mat
marrón cuero, mate
castanho couro, fosco
marrone cuoio, opaco
läderbrun, matt
nahkanruskea, himmeä
läderbrun, mat
läzbrun, matt
коричневая кожа, матовый
brunatny jak skóra, matowy
καφέ δερμάτινο, ματ
deri kahverengi, mat
kožené hnědá, matná
börbarna, matt
koža rjava, mat

75%

anthrazit, matt 9
anthracite grey, matt
anthracite, mat
antraciet, mat
antracita, mate
antracite, fosco
antracite, opaco
antracit, matt
antrasiti, himmeä
koksgrå, mat
antrasit, matt
антрацит, матовый
antracyt, matowy
ανθρακι, ματ
antrasit, mat
antracit, matná
antracit, matt
tamno siva, mat

N

25 %

eisen, metallic 91
steel, metallic
coloris fer, métallique
ijzerkleurig, metallic
ferroso, metalizado
ferro, metálico
ferro, metallico
järnfärg, metallic
teräksenvärinen, metallikiilto
jern, metallak
jern, metallic
стальной, металл
żelazo, metaliczny
σιδηρού, μεταλλικό
demir, metalik
železná, metaliza
vas, metáll
železná, metalik

O

weiß, matt 5
white, matt
blanc, mat
wit, mat
bianco, mate
branco, fosco
bianco, opaco
vit, mat
valkoinen, himmeä
hvid, mat
hvit, matt
белый, матовый
biały, matowy
λευκό, ματ
beyaz, mat
bilá, matná
fehér, matt
bela, mat

33 %

Dunkelgrün, matt 39
Dark green, matt
Vert foncé, mat
Donkergroen, mat
Verde oscuro, mate
Verde oscuro, mate
Mörkgrön, matt
Tummanvihreä, matta
Mörkgrön, mat
Темно-зеленый, матовый
Ciemnozielony, matowy
Πράσινο σκούρο, ματ
Koyu yeşil, mat
Sötétzöld, matt
Tmavomodrá, matná
Temnozelená, brez leska

P

67 %

khakibraun, matt 86
olive brown, matt
brun khaki, mat
khakibruin, mat
caqui, mate
castanho caqui, fosco
marrone caqui, opaco
kaki-brun, matt
khakiruskea, himmeä
khakibrun, mat
khakibrun, mat
коричневый "хаки", матовый
brązowy khaki, matowy
καφε-χακί, ματ
hâki renkli, mat
hnědá khaki, matná
kekibarna, matt
kaki rjava, mat



Öffnungen mit Spachtelmasse verschließen und Oberfläche mit Schleifpapier angleichen
Close openings with putty and sand down surface
Reboucher les orifices avec du mastic et uniformiser les surfaces avec du papier à corner.
Dicht de openingen af met plamuur en maak het oppervlak glad met schuurpapier.
Rellenar las aberturas con masilla de emplastecer y alisar con papel de lija
Fechar as aberturas com massa de aparelhar e igualar a superfície com uma lixa
Chiudere le aperture con stucco e uguagliare la superficie con carta abrasiva
Stäng öppningarna med spackelmasa och jämna till ytan med slippapper
Sulje aukot siloteaineella ja tasoitaa pinta hiekkapaperilla.
Åbningen lukkes med spartelmasse og overfladen gøres plan med sandpapier
Tett åpningene med sparkel og puss overflaten med sliperappir.
Шели заделать шпаклевкой и выровнять поверхность шлифовальной бумагой
Zatkąć otwory masą szpachlową i wygładzić powierzchnie papierem ściernym
Κλείστε τ' ανοίγματα με στόκο και λείψετε την εξωτερική επιφάνεια με γυαλόχαρτο
Delikleri macun ile kapatın ve üst yüzeyi zımpara kağıdı ile düzeltin
Otvory překryť tmelem a povrch vyrovnať smirkovým papierom
Nyílásokat alapozomással zárnai és a felületet dörzspapírral elegyengetni
Zatvoriti otvore smesom za popunjavanje a površinu poravnati brusnim papirom



Wegfeilen
File off
Enlever avec une lime
Wegvlijen
Retirar
Eliminare
Tag loss
Poista
Fjernes
Fjern
Удалить
Usun
απομακρύνετε
Temizleyin
Odstranit
eltávolítani
Ostrantiti



Nicht benötigte Teile
Parts not used
Pièces non utilisées
Niet benodigde onderdelen
Piezas no necesarias
Peças não utilizadas
Parti non usate
Inte använda delar
Tarpeettomat osat
Ikke nødvendige dele
Deler som ikke er nødvendige
Ненужные детали
Elementy niepotrzebne
μη χρειαζόμενα εξαρτήματα
Gereksiz parçalar
Nepotřebné díly
fel nem használt alkatrészek
Nepotrebni deli

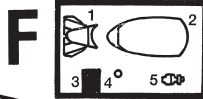
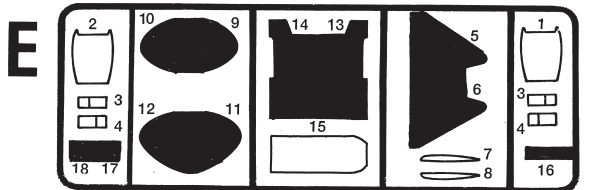
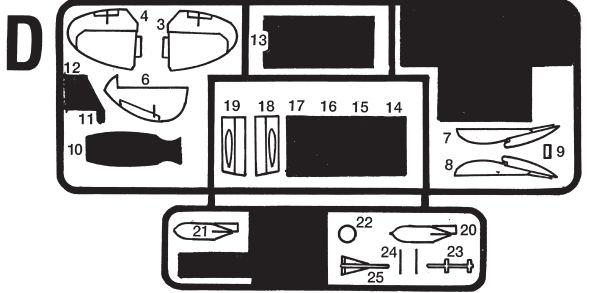
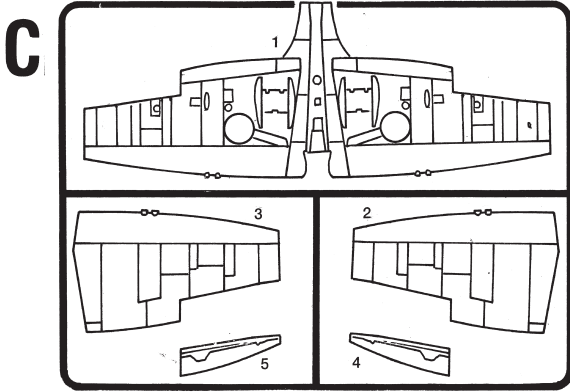
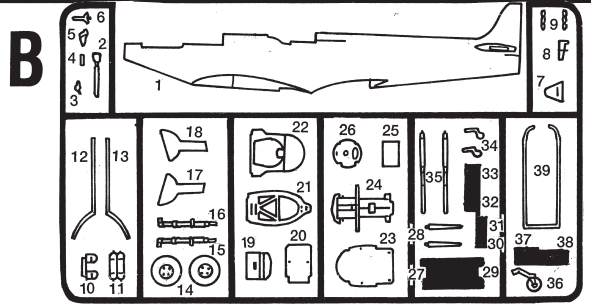
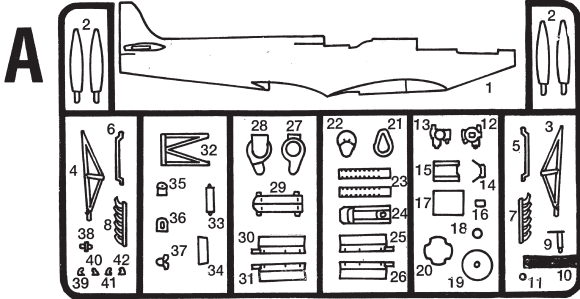

1. Version ? A

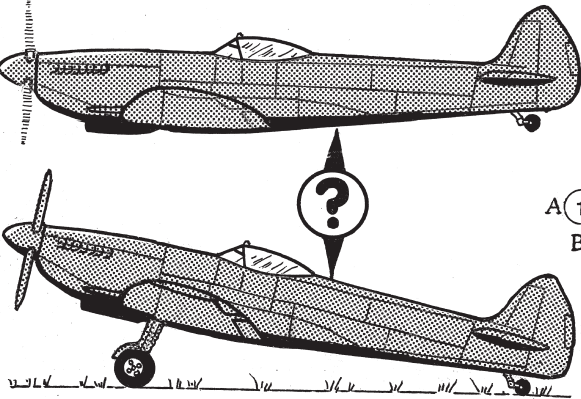

2. Version ? B

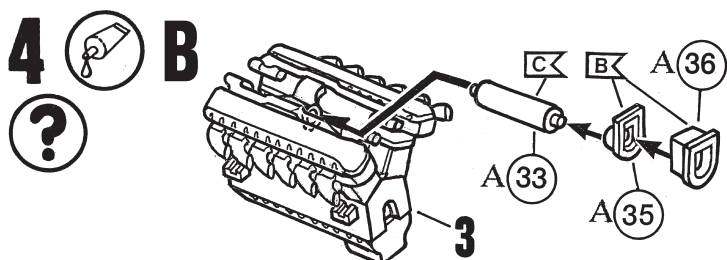
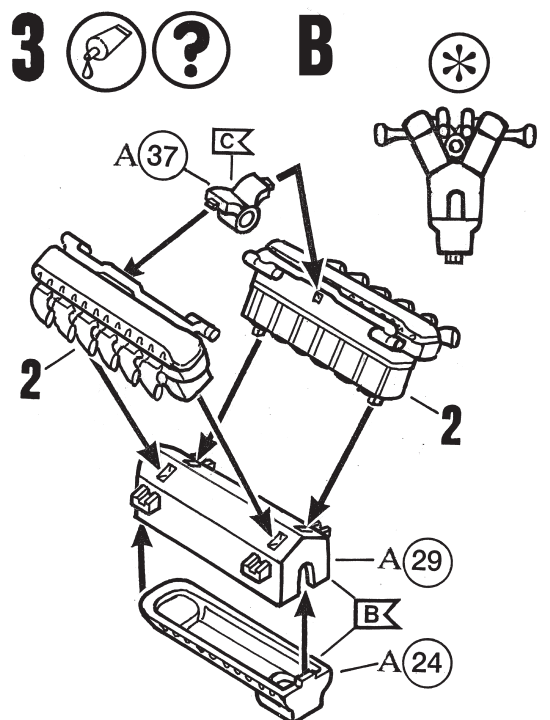
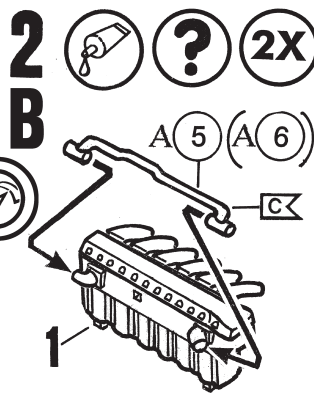
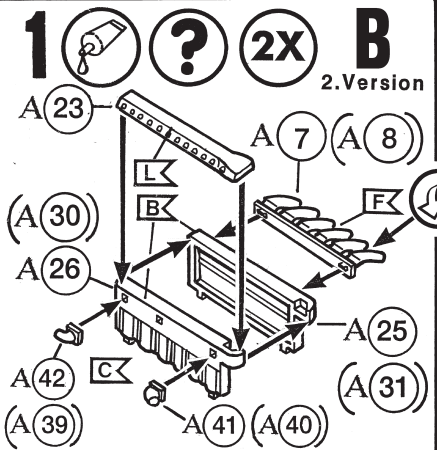
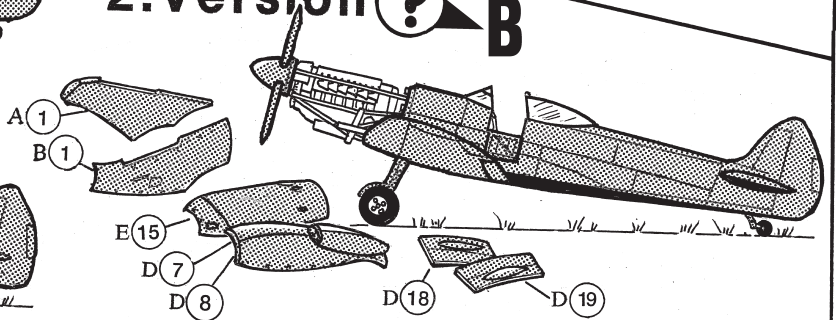

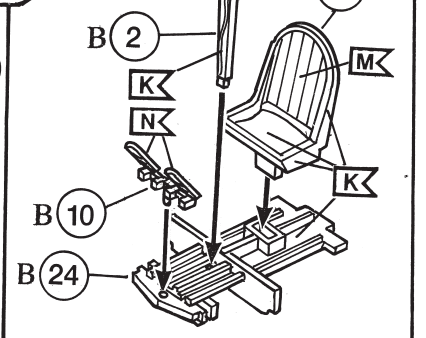
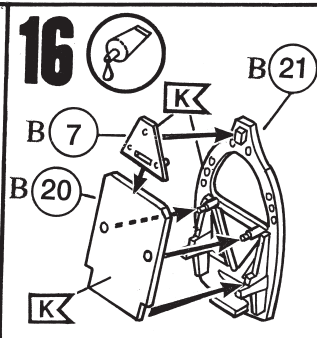
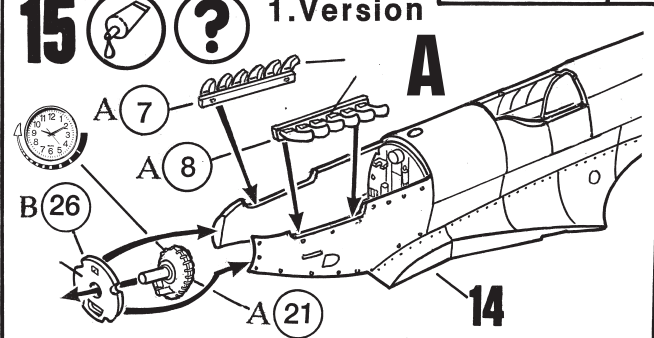
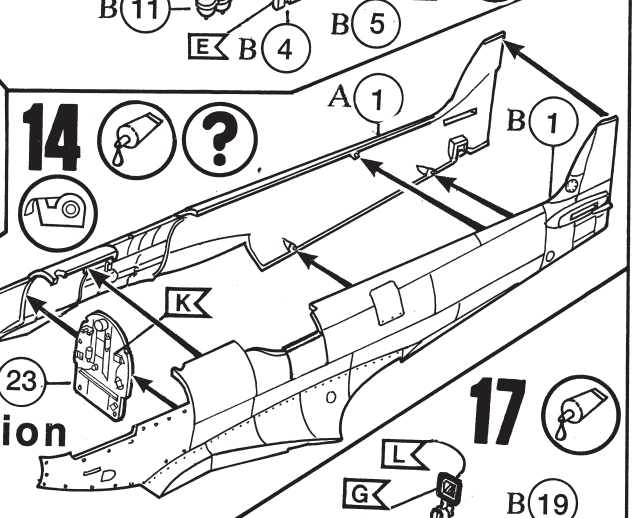
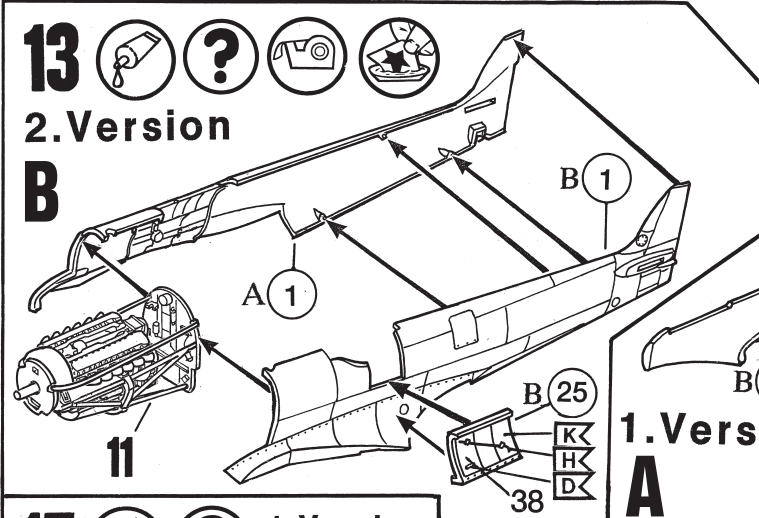
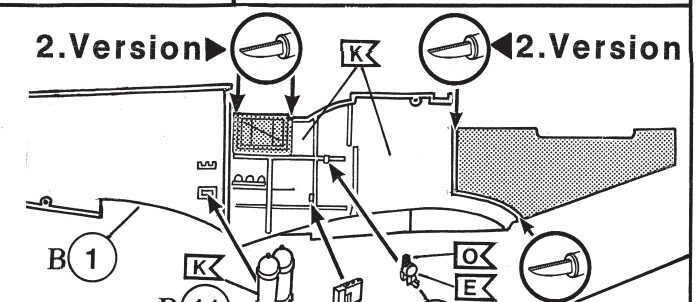
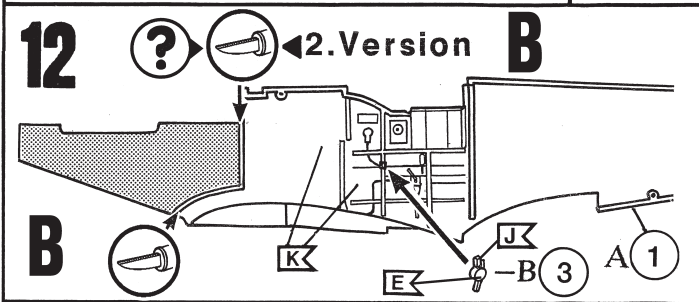
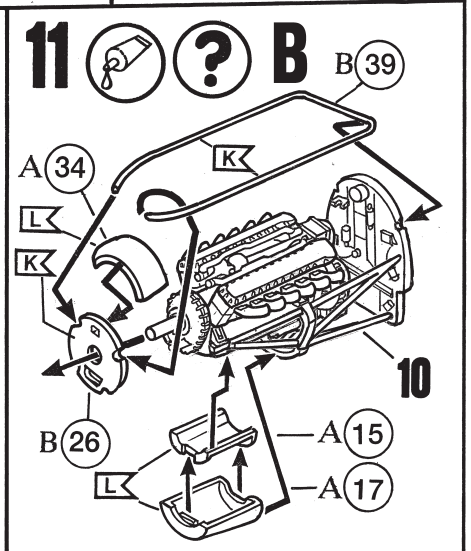
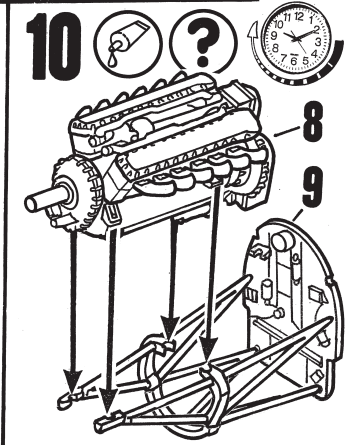
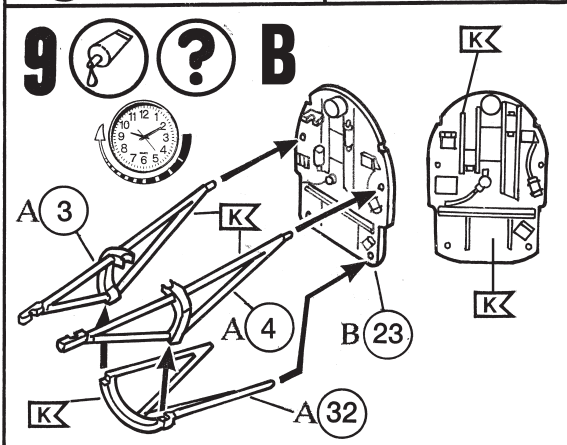
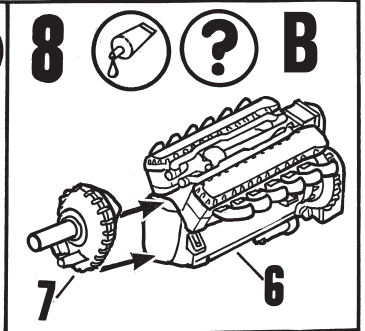
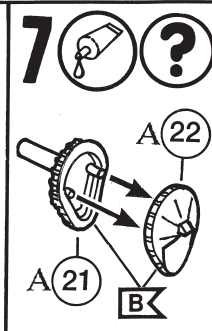
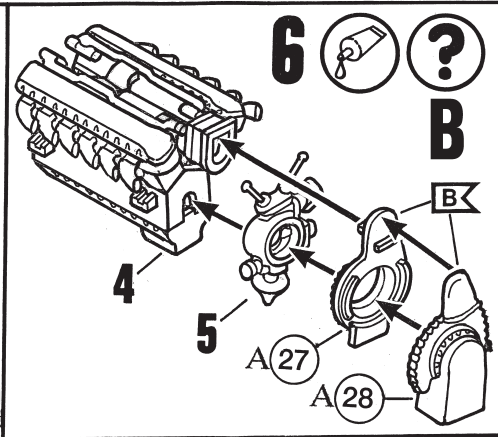
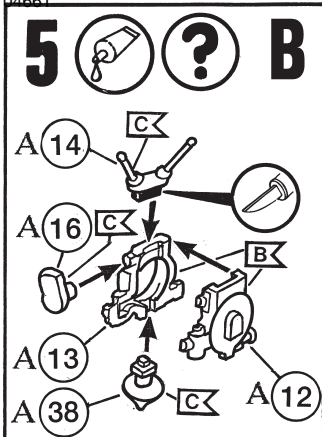

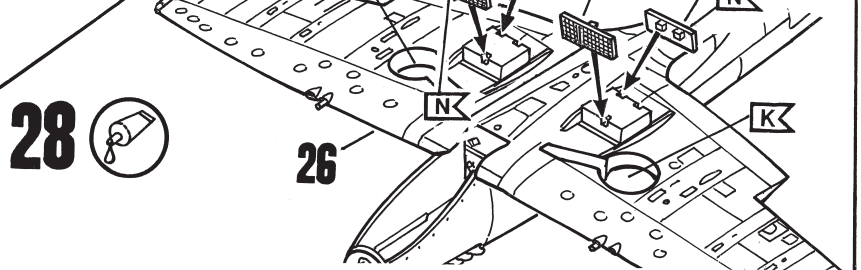
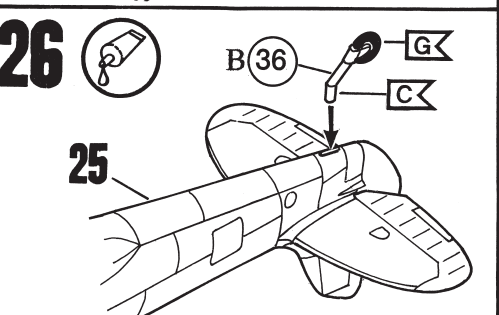
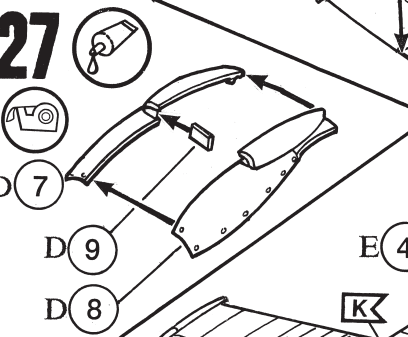
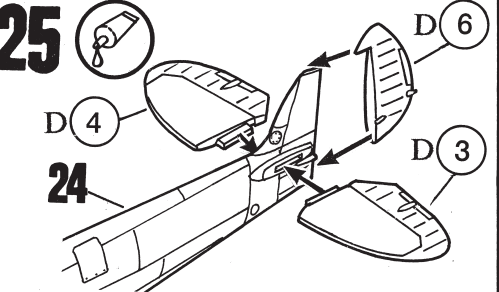
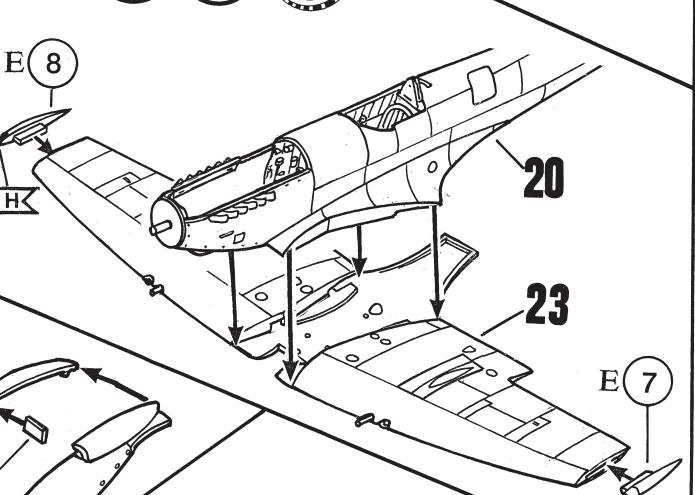
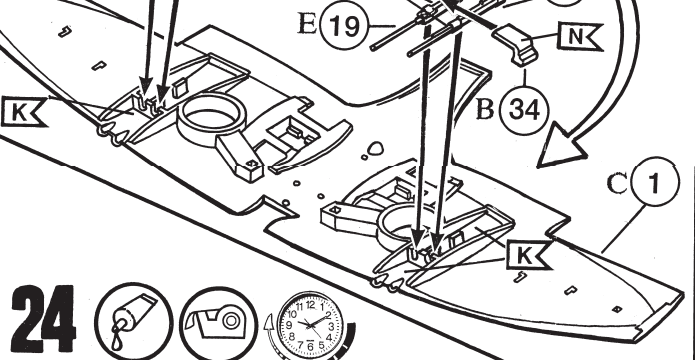
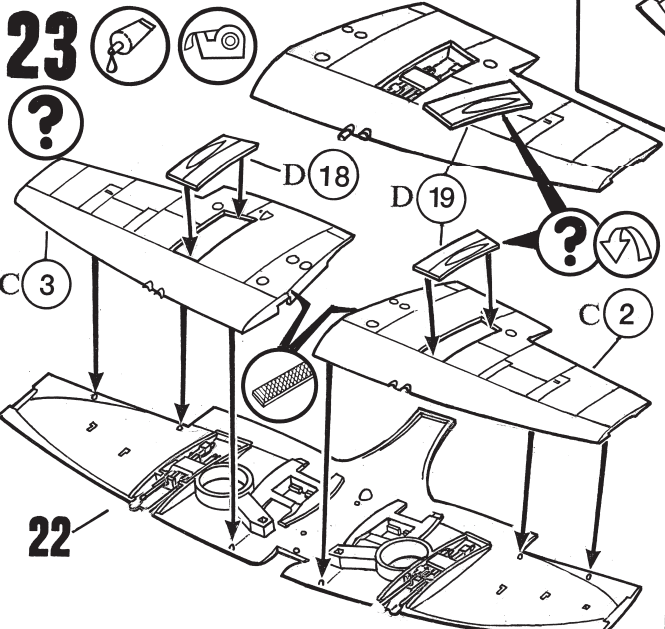
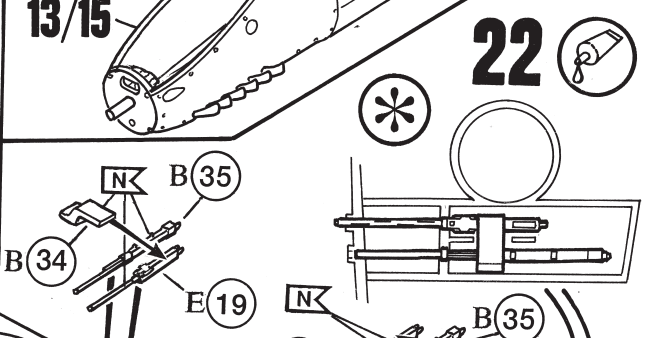
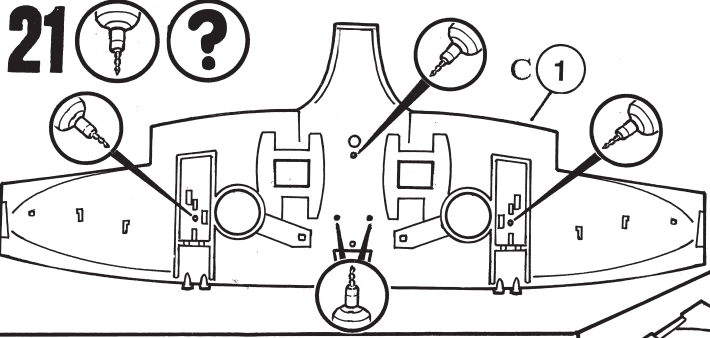
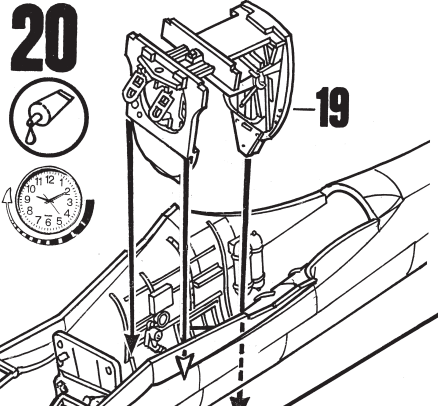
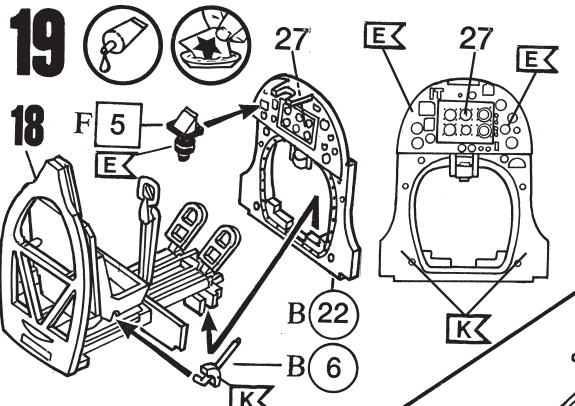
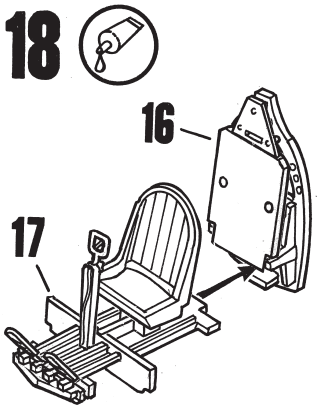

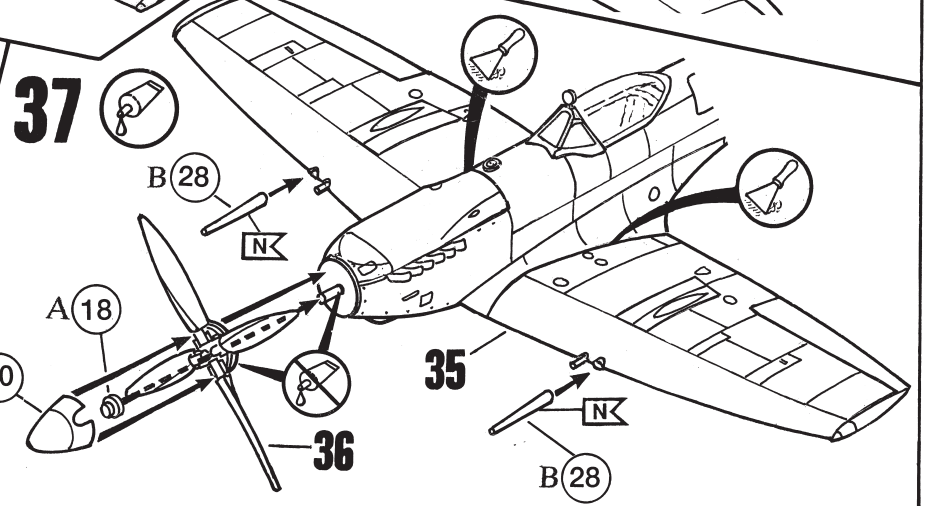
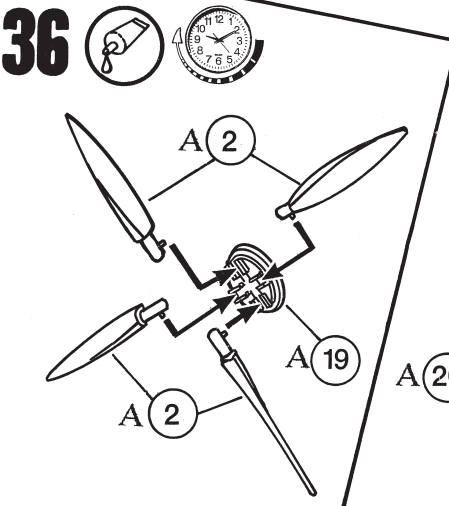
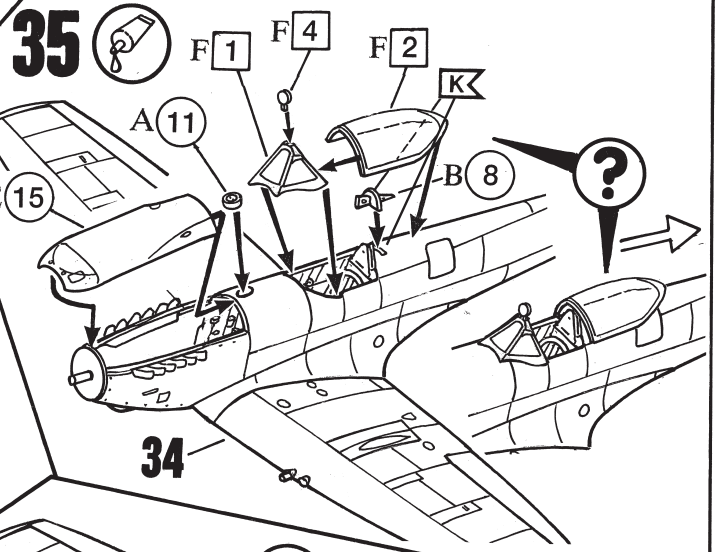
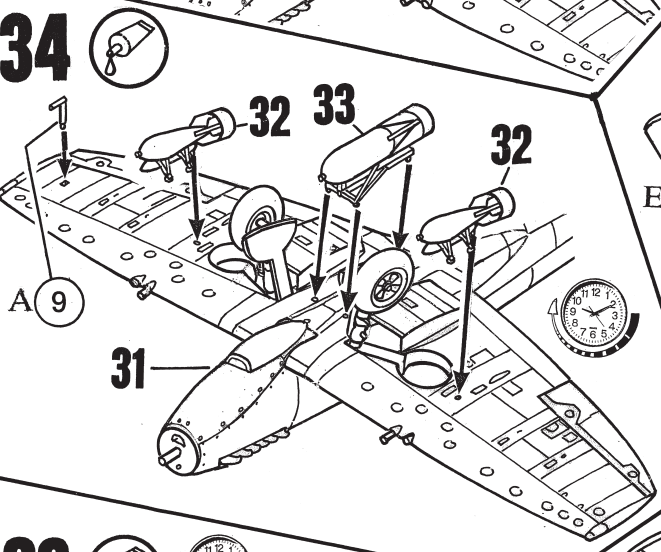
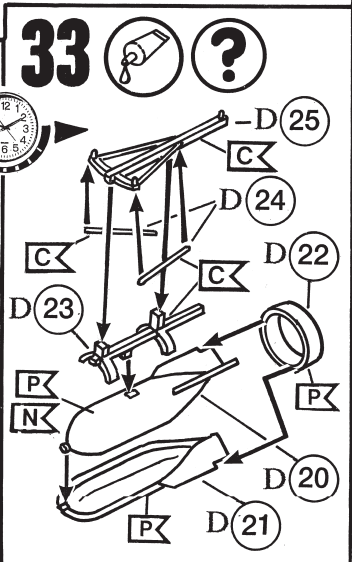
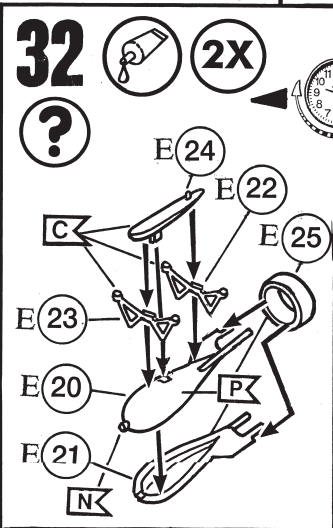
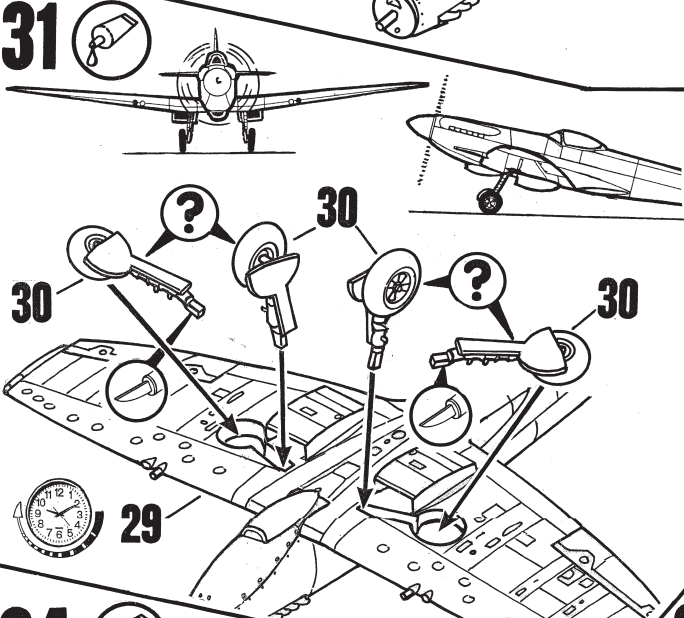
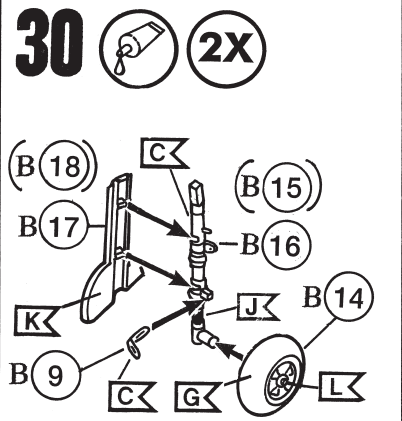
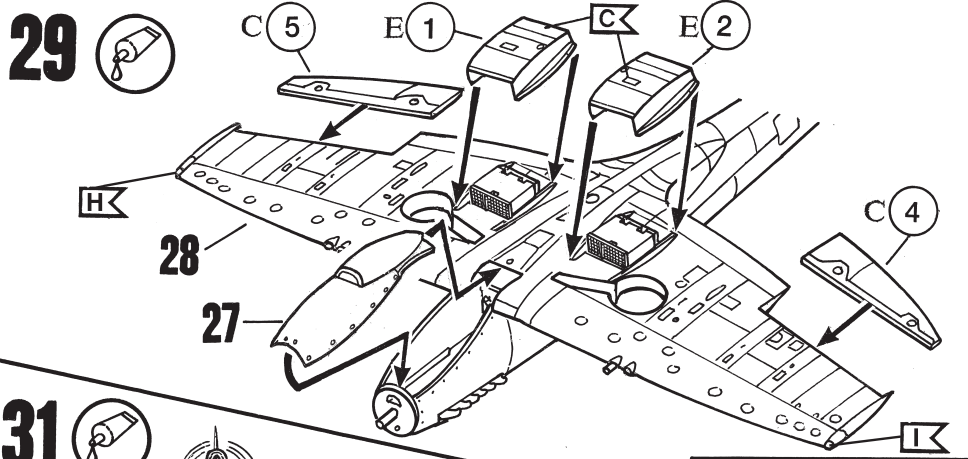

Supermarine Spitfire Mk.XVI, No.421 Squadron, Royal Canadian Air Force, Germany, April 1945.

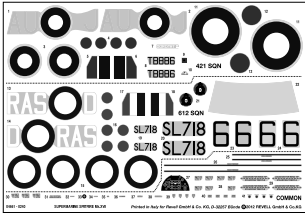

38

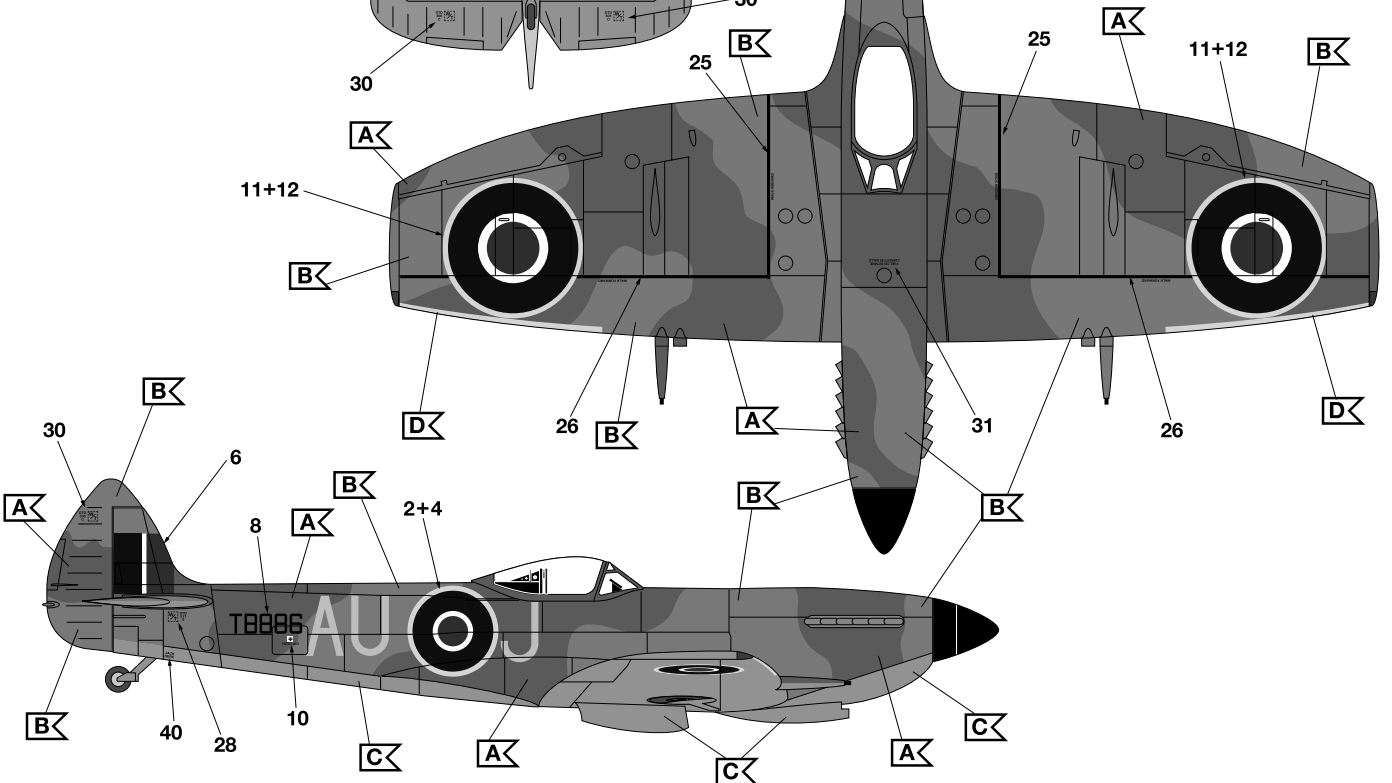
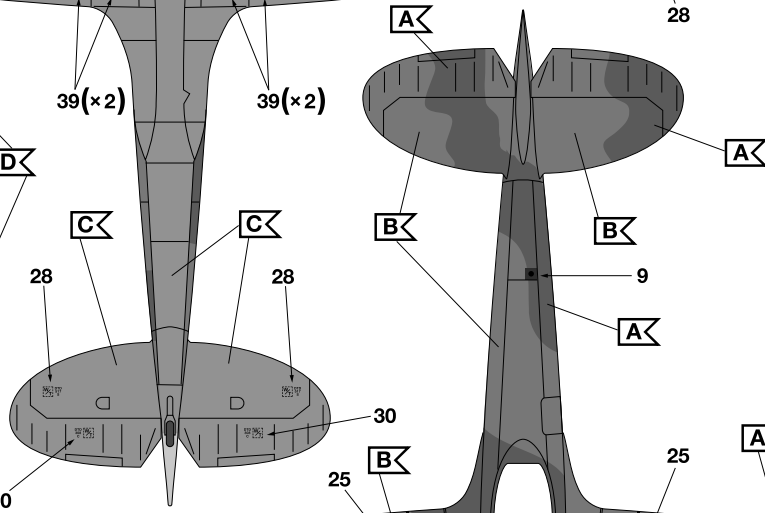
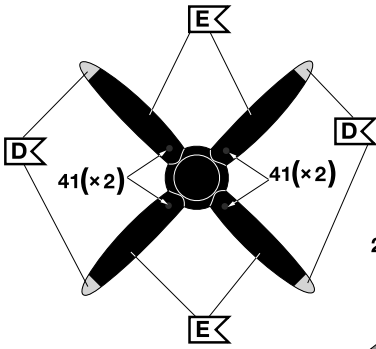
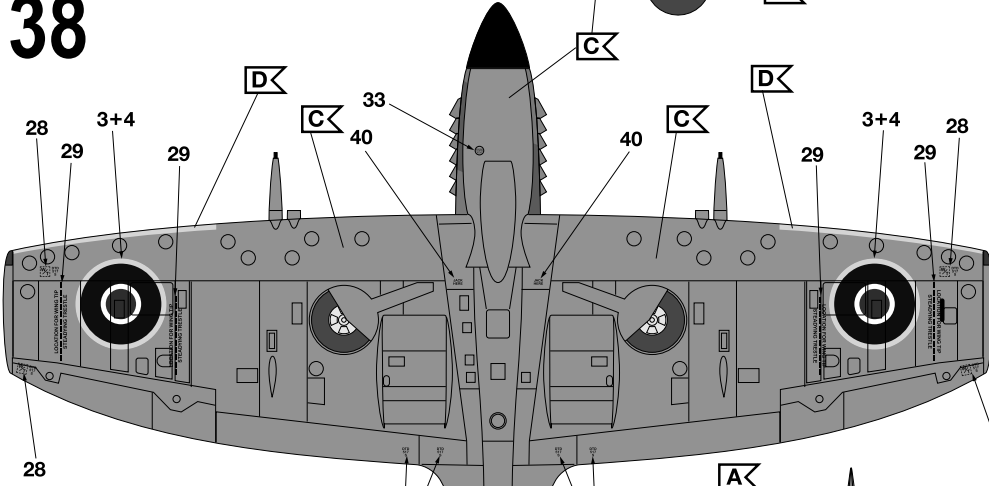
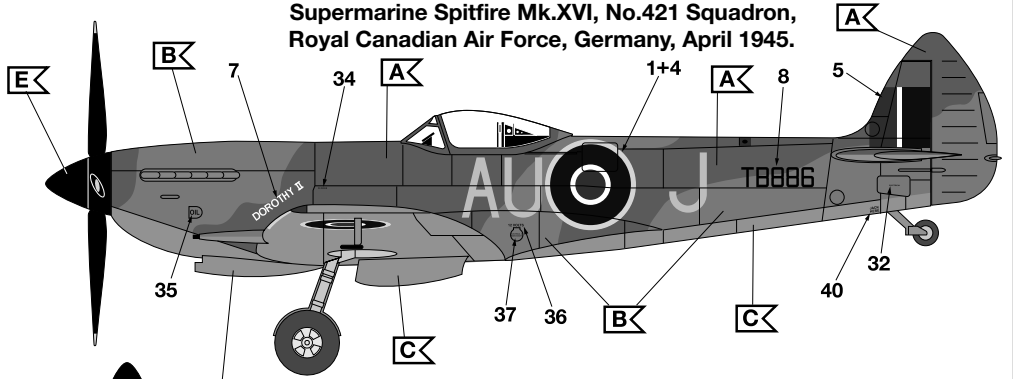

Supermarine Spitfire Mk.XVI, No.612 Squadron,
Royal Auxiliary Air Force, Dyce, Scotland, August 1949.

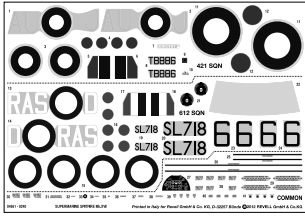

39

