



Dornier Do-27H-2 'Three Blade Propeller'

INSTRUCTIONS / NÁVOD



In the post war year, many German aircraft designers feared the possible ban on aircraft production and begun to leave the country. Among them also Claudius Dornier Jr., the son of the famous German WW2 aircraft builder. He settled in Spain where he founded company named Oficinas Técnicas Dornier (OTEDO). In the middle 50's, the Spanish Air Ministry was looking for a new STOL aircraft and having received the order, Dornier designed the Dornier Do 25 type, a high wing aircraft for a crew of four. Two prototype airframes were built by CASA company in Spain, while in Germany, in rebuilt Dornier works, the type was redesigned to the Do 27, powered by the Lycoming GSO-480-B1B6 engine. This type was also finally put into production, becoming the first aircraft to be mass-produced in Germany after the war. In total, 428 airframes were built in several different versions and they were operated by all three services of the newly built German military, ie. the air force, navy and land forces. At the same time, a 50-unit batch was also produced in Spain for their military, named the CASA C-127/U.9. The type's many versions differed mainly by the style of the undercarriage, engine and propeller used, the shape of the tail fin or by having either single or twin controls in the cockpit. The Dornier Do 27 was not only used by air forces of many European countries, namely by Portugal, Belgium, Sweden, Switzerland and some others, but also elsewhere over the globe. It could be seen flying in several African countries, in the State of Israel and also in Turkey. The type found its way to civil aviation market too and was quite liked by so-called bush pilots for its excellent performance in harsh conditions of irregular transport lines in Africa or South America. In Europe, the Do 27 served as touring or skydiving aircraft.

Wingspan: 12.0 m, Length: 9.6 m, Max. Speed 210 kmh, Range: 1,350 km, Ceiling: 5,000 m.



Dr. Claudius Dornier ml. odešel po druhé světové válce, podobně jako jiní němečtí konstruktéři do zahraničí. Obával se zákazu stavby letadel. Založil ve Španělsku továrnu OTEDA (Oficinas Técnicas Dornier). Zde zkonstruoval v polovině padesátých let na objednávku španělského ministerstva letectví čtyřmístný celokovový hornoplošník s vlastnostmi STOL označený Dornier Do 25. Dva prototypy byly postaveny továrnou CASA. První prototyp byl poháněn motorem Elizalde Tigre G-IV-B, druhý Continentalem O-470-J. Oba motory se ale ukázaly slabé. V rekonstruované továrně Dornier v Německu vznikl na základě Do 25 nový prototyp Dornier Do 27 s motorem Lycoming GSO-480-B1B6. Dornier Do 27 byl přijat do sériové výroby a stal se prvním velkosériově vyráběným letadlem v Německu po druhé světové válce. Celkově bylo vyrobeno 428 ks letadel, které odebíraly postupně v několika verzích tři složky nově budovaných německých ozbrojených sil, letectvo, námořnictvo i pozemní síly. Zároveň se ve Španělsku rozeběhla výroba padesátikusové série pro španělské letectvo s označením CASA C-127/U.9. Dornier Do 27 byl vyráběn v několika verzích lišících se podvozkem, typem motoru a použité vrtule, dvojím nebo jednoduchým řízením a tvarem svislé ocasní plochy. Do 27 byl dodáván mnoha evropským ozbrojeným silám (např. Portugalsko, Belgie, Švédsko, Švýcarsko), létal ale i jinde ve světě. Kromě několika afrických zemí i v Brazílii, státu Izrael a Turecku. Mimo vojenských sil se Do 27 dočkaly širokého uplatnění u civilních uživatelů. Letouny byly s oblibou používány „bush piloty“ v drsných podmínkách nepravidelné dopravy v Africe a Jižní Americe. V Evropě byly používány jako turistické a k vysazování parašutistů. Nejslavnějším civilním Do 27 byl patrně „zebrí stroj“ Bernharda Grzimeka použitý při filmování zvěře v Africe. Některé civilní stroje létají dodnes.

Rozpětí: 12,0 m, délka: 9,6 m, max. rychlost: 210 km/h, dolet 1 350 km, dostup: 5 000 m.

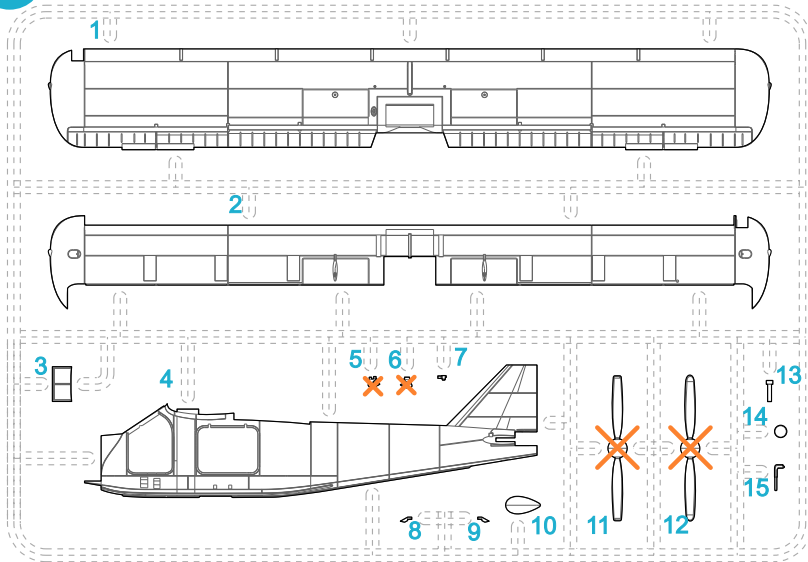
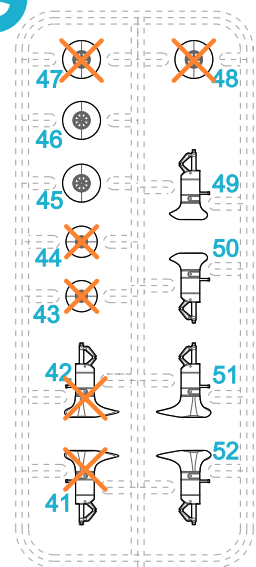
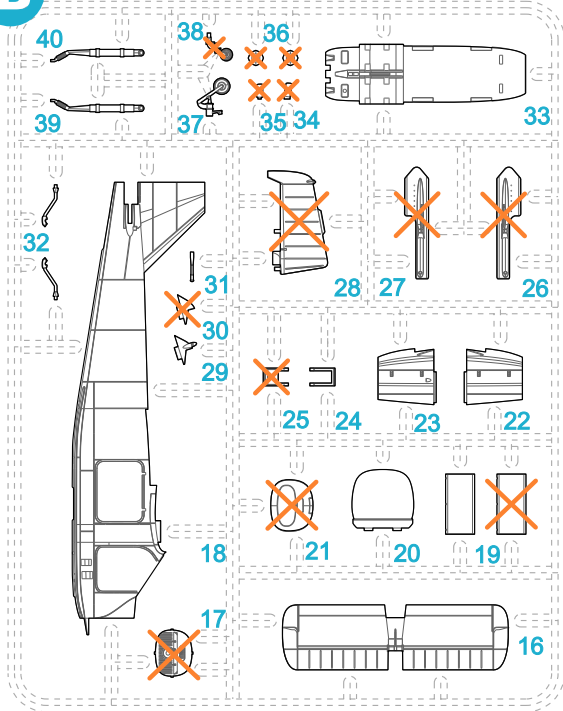
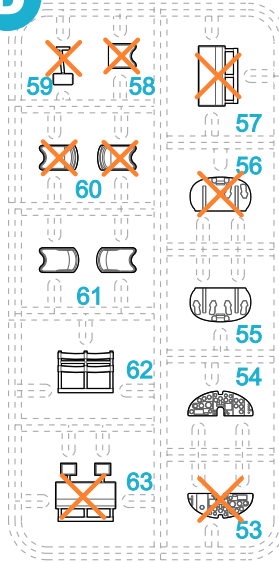
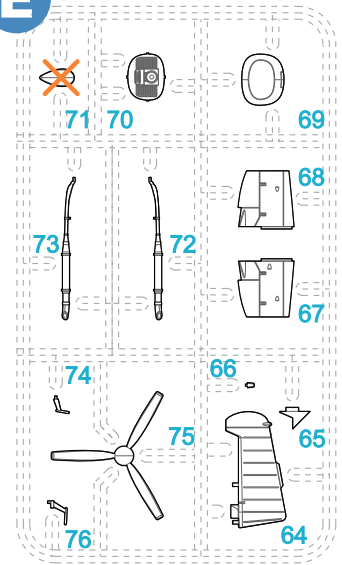
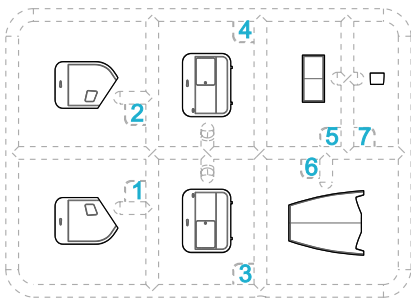
A**C****B****D****E****CLEAR PARTS (CP)****PHOTO-ETCHED PARTS (PP)**

X Tento díl nepoužít.
Do not use this part.

Barvy GUNZE/ GUNZE Colour No.

A	Black / černá	H12/C33
B	Gray / šedá	H325/C325
C	Aluminium / hliník	H8/C8
D	Leather / hnědočervená	H47/C41
E	Brown / hnědá	H310/C310
F	Linen (Tan) / plátno	H27/C44
G	Red / červená	H3/C3
H	Burnt Iron / opálený kov	H76/C61
I	Tire Black / barva pneu	H77/C137
J	Clear Red / červená čirá	H90/C47
K	Clear Green / zelená čirá	H94/C138
L	Chrome Silver / chrom. stříbrná	MC211
M	White / bílá	H1/C1
N	Yellow / žlutá	H4/C4
O	Olive Yellow / olivová žlutá	H340/C340

SYMBOLS

? MOŽNOST VOLBY
OPTIONAL
NACH BELIEBEN
OPTION

💧 POUŽÍT KYANOAKRYLÁTOVÉ LEPIDLO
INSTANT CYANOACRYLATE GLUE
ZYANOAKRYLÁTKLEBER
COLLE CYANOACRYLATE

↩ OHNOUT
BEND
BIEGEN
COURBER

✋ ZHOTOVIT NOVÉ
SCRATCH BUILD
FERTIGSTELLEN
ACHEVER

✂ ŘEZAT/VRTAT
CUT OFF/DRILL
ENTFERNEN
COUPER/PERCER

A NATŘÍT
COLOUR
FARBEN
PEINDRE
GSI
colour
code

1

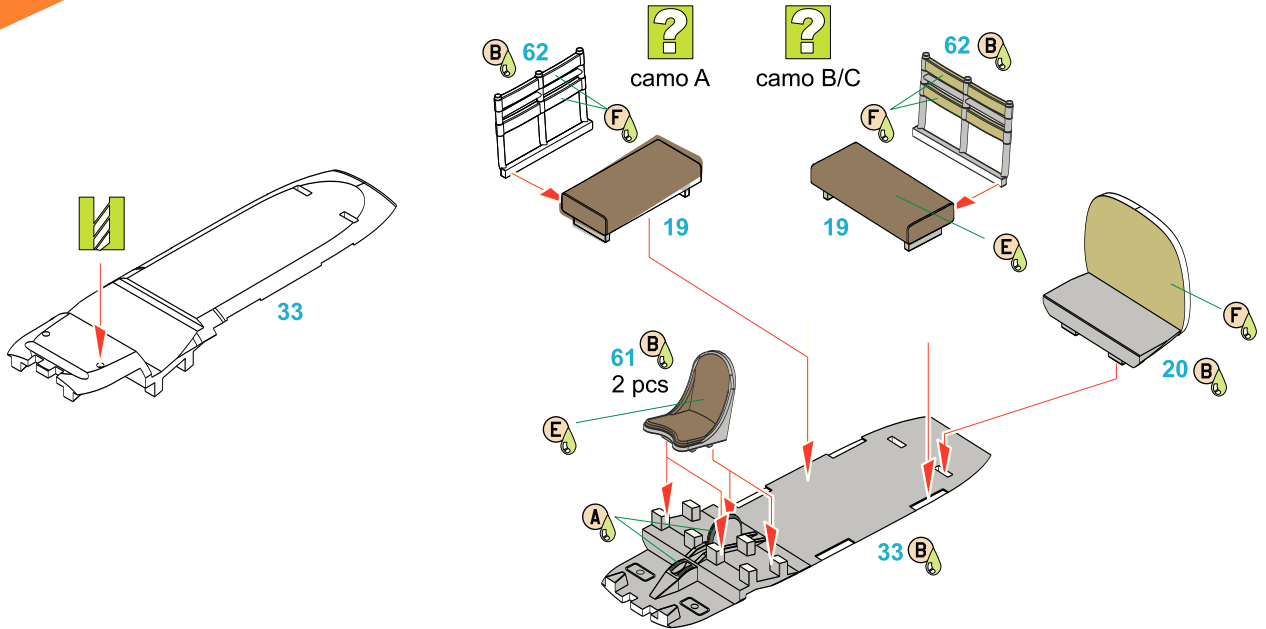

2

STEP 1
camo A

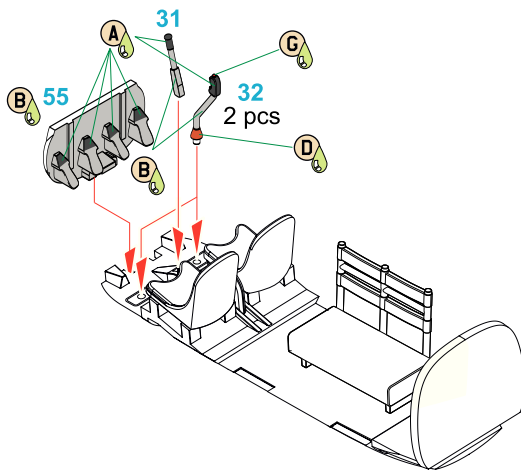

STEP 1
camo B/C

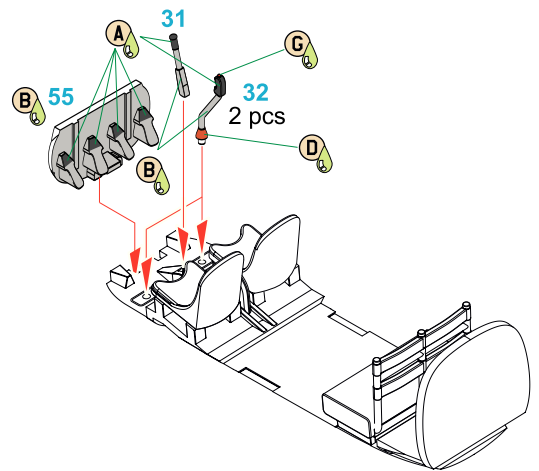

3

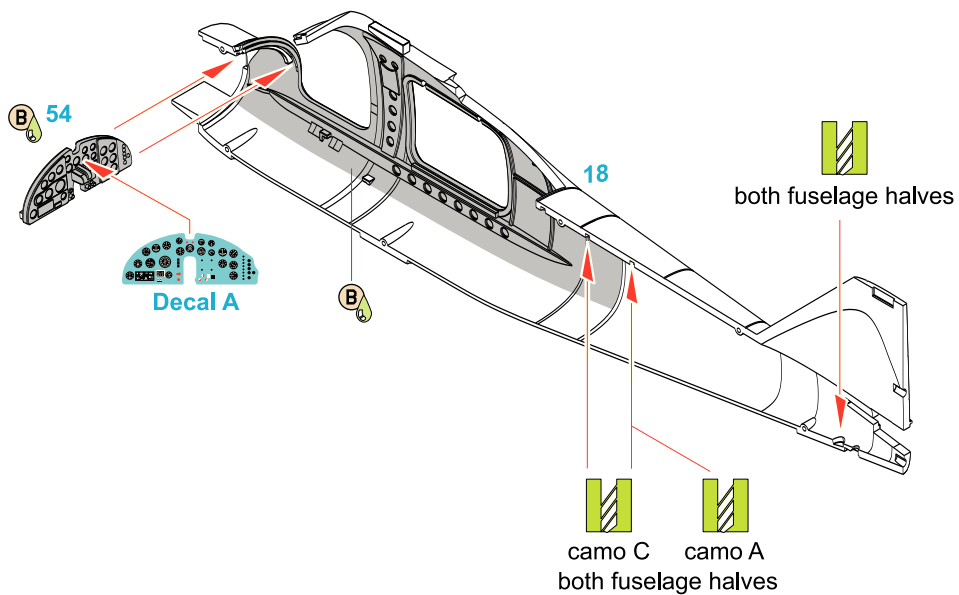

4

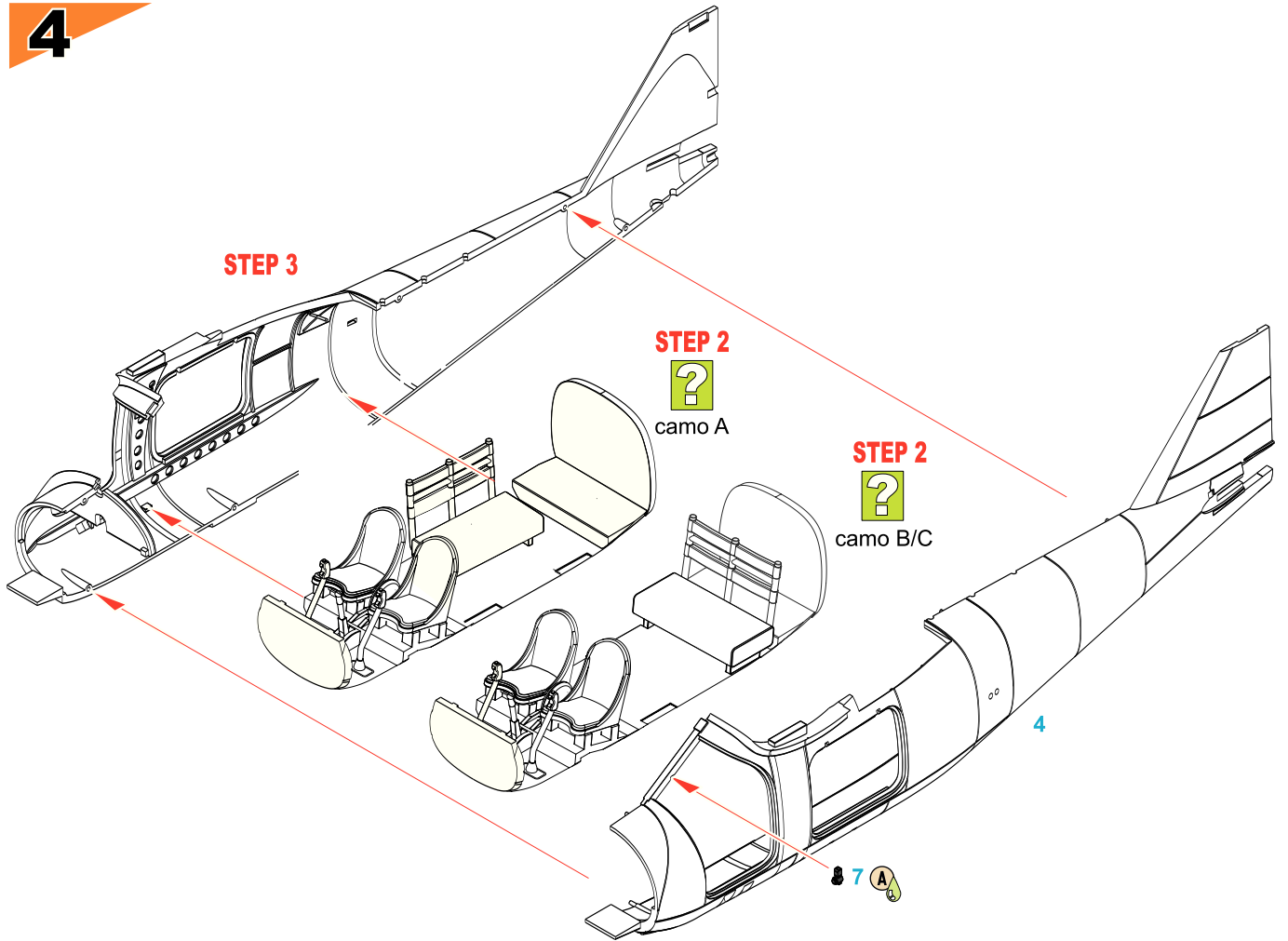

5

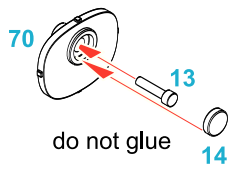

6

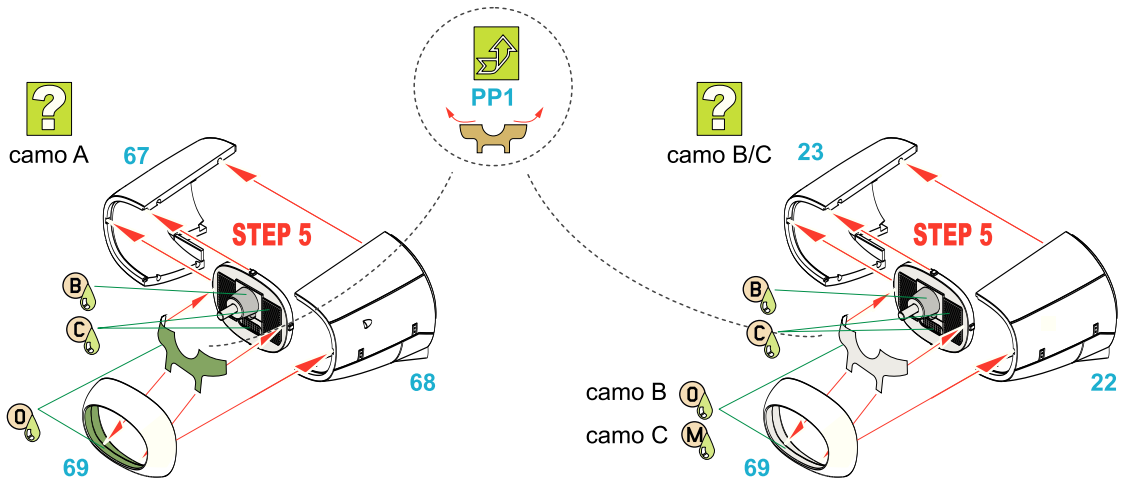

7

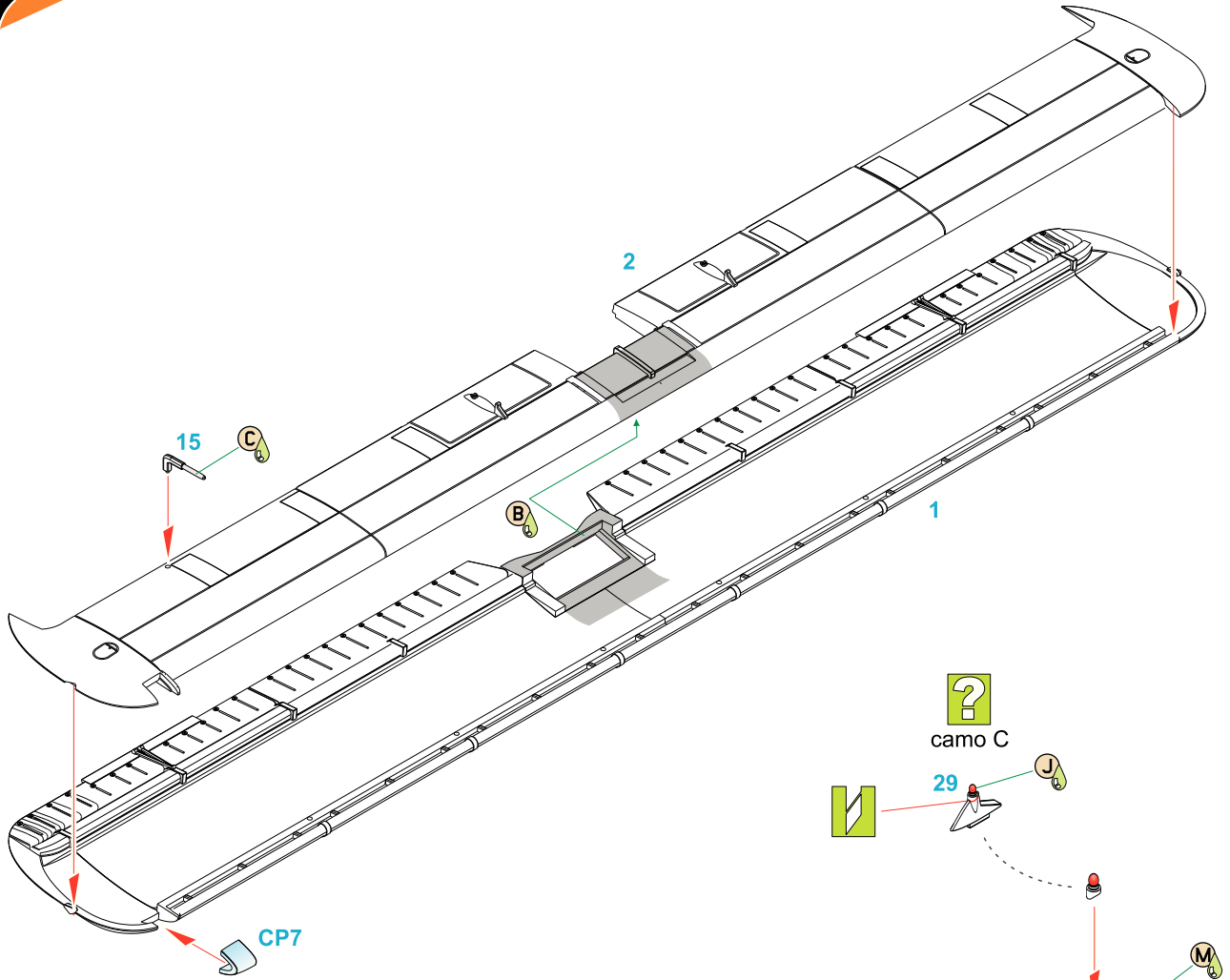

8

STEP 6

 camo B/C

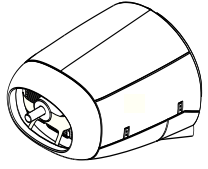

STEP 6

 camo A

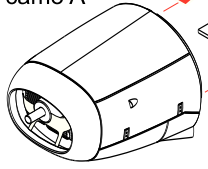

STEP 4

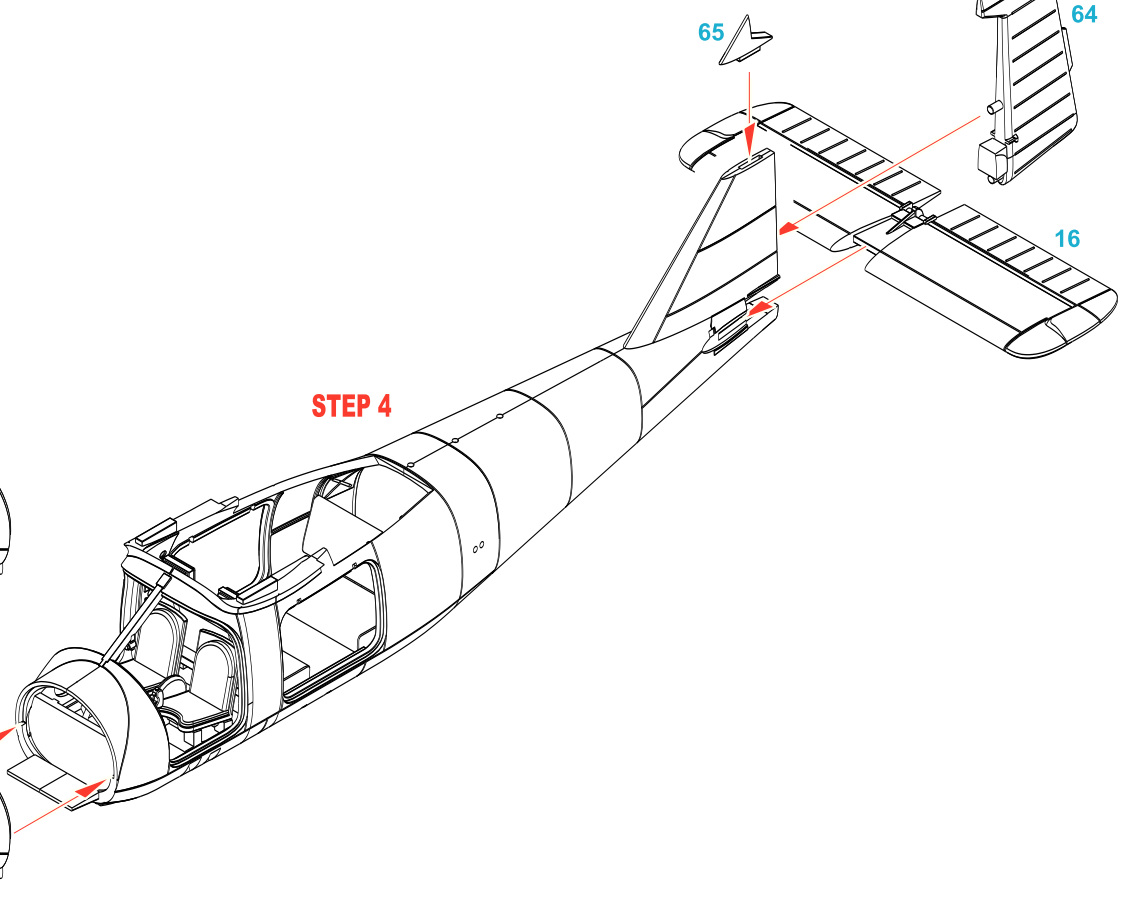

9

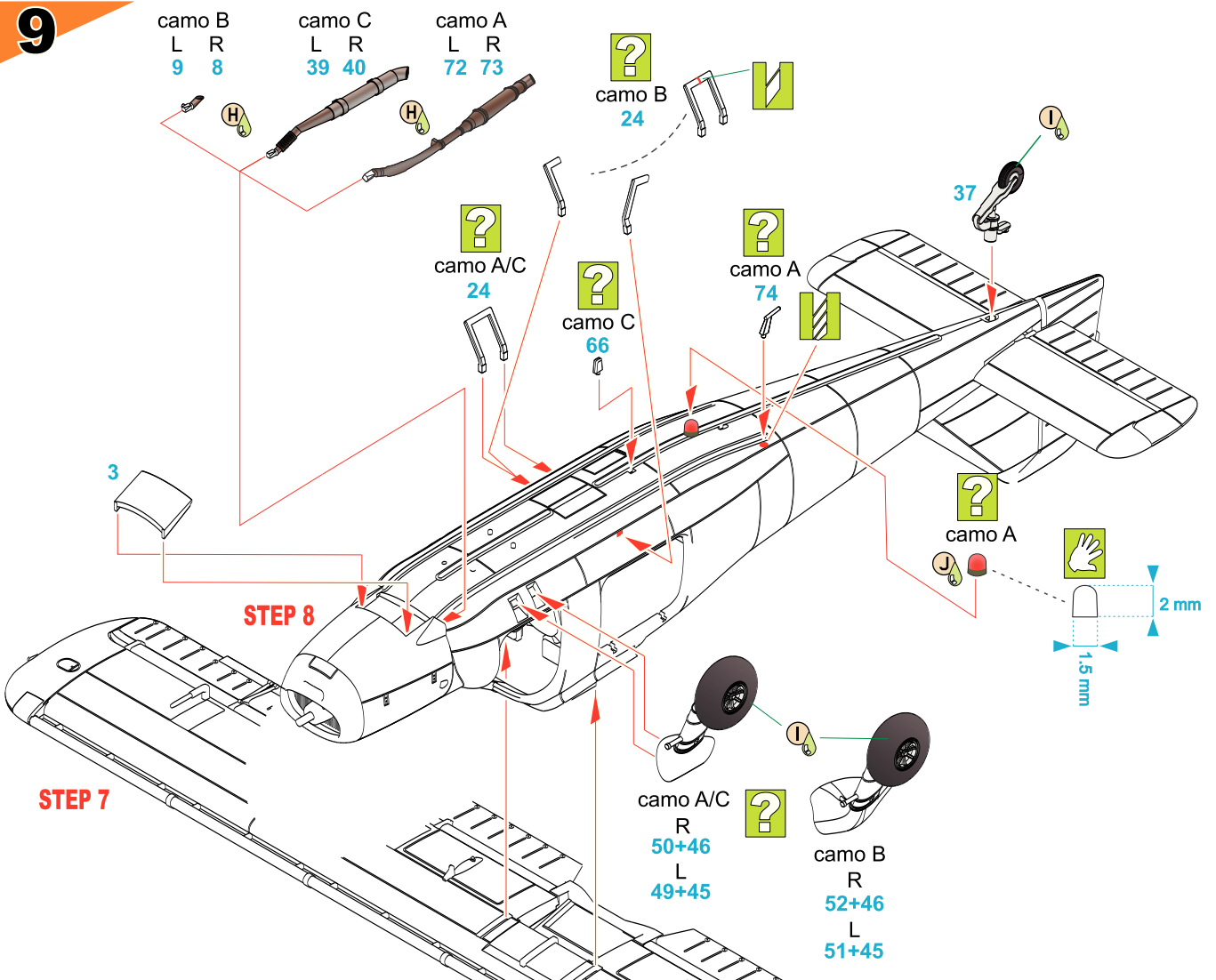

10

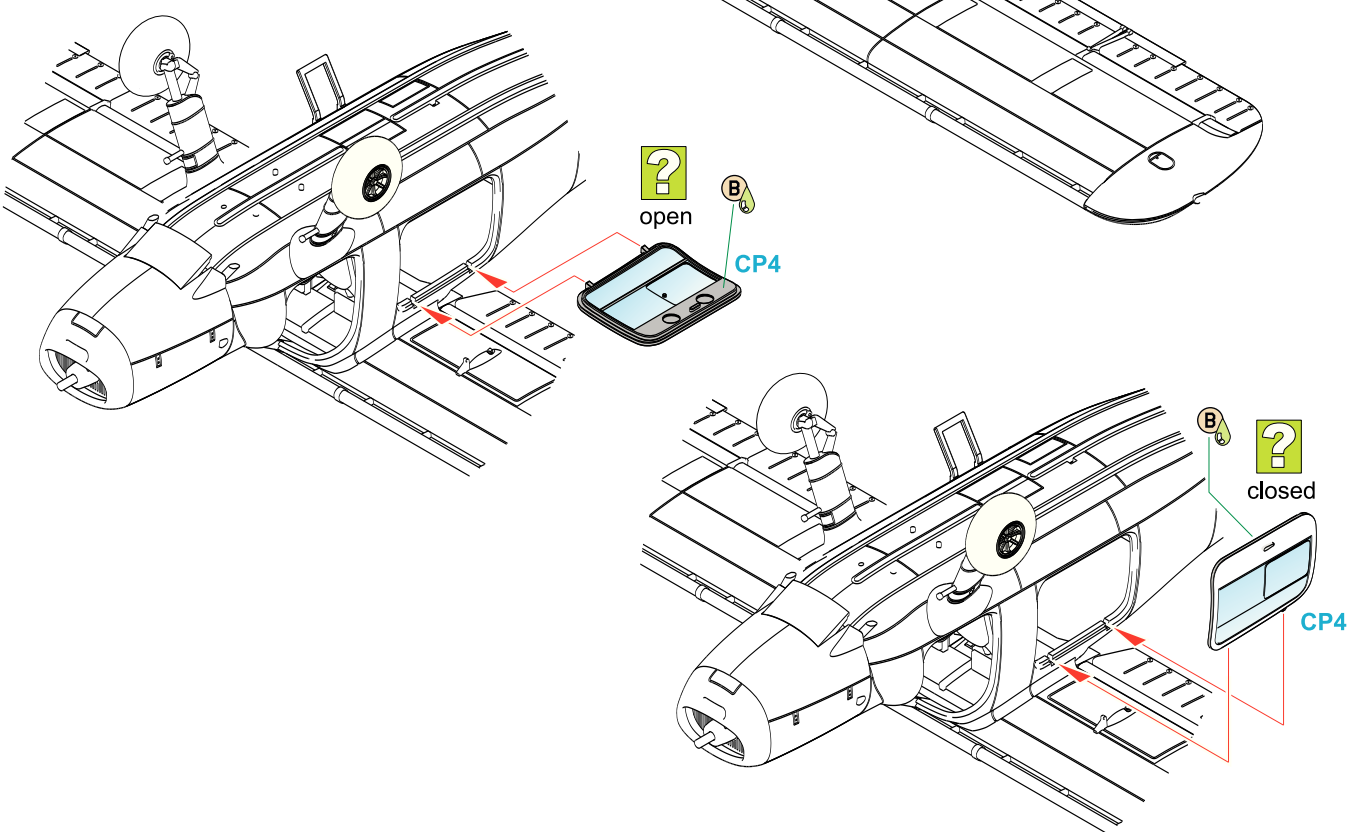

11

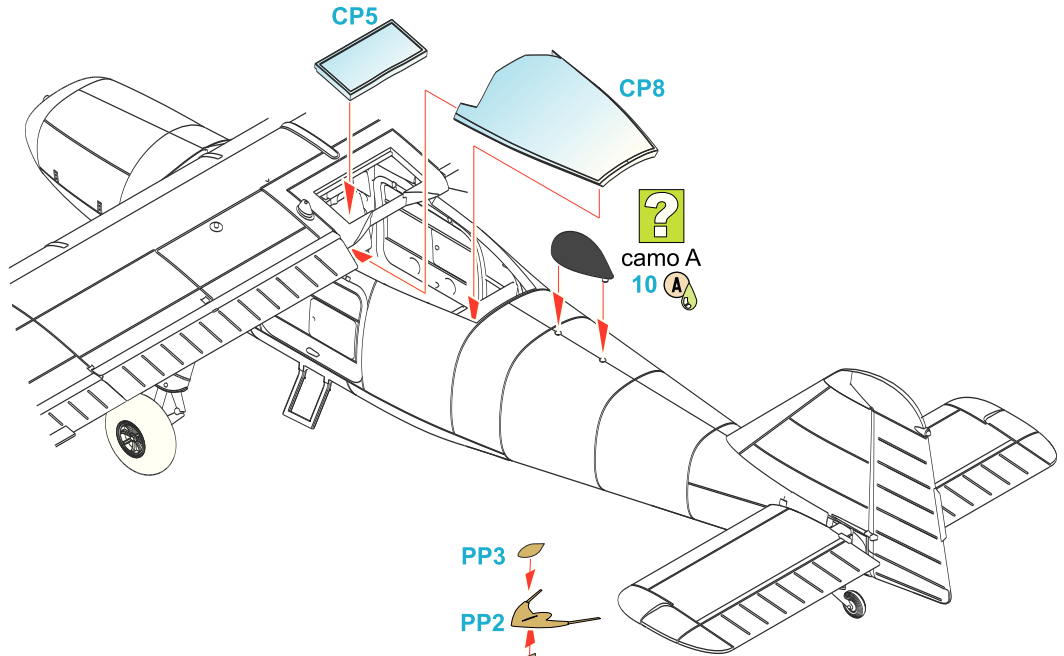

12

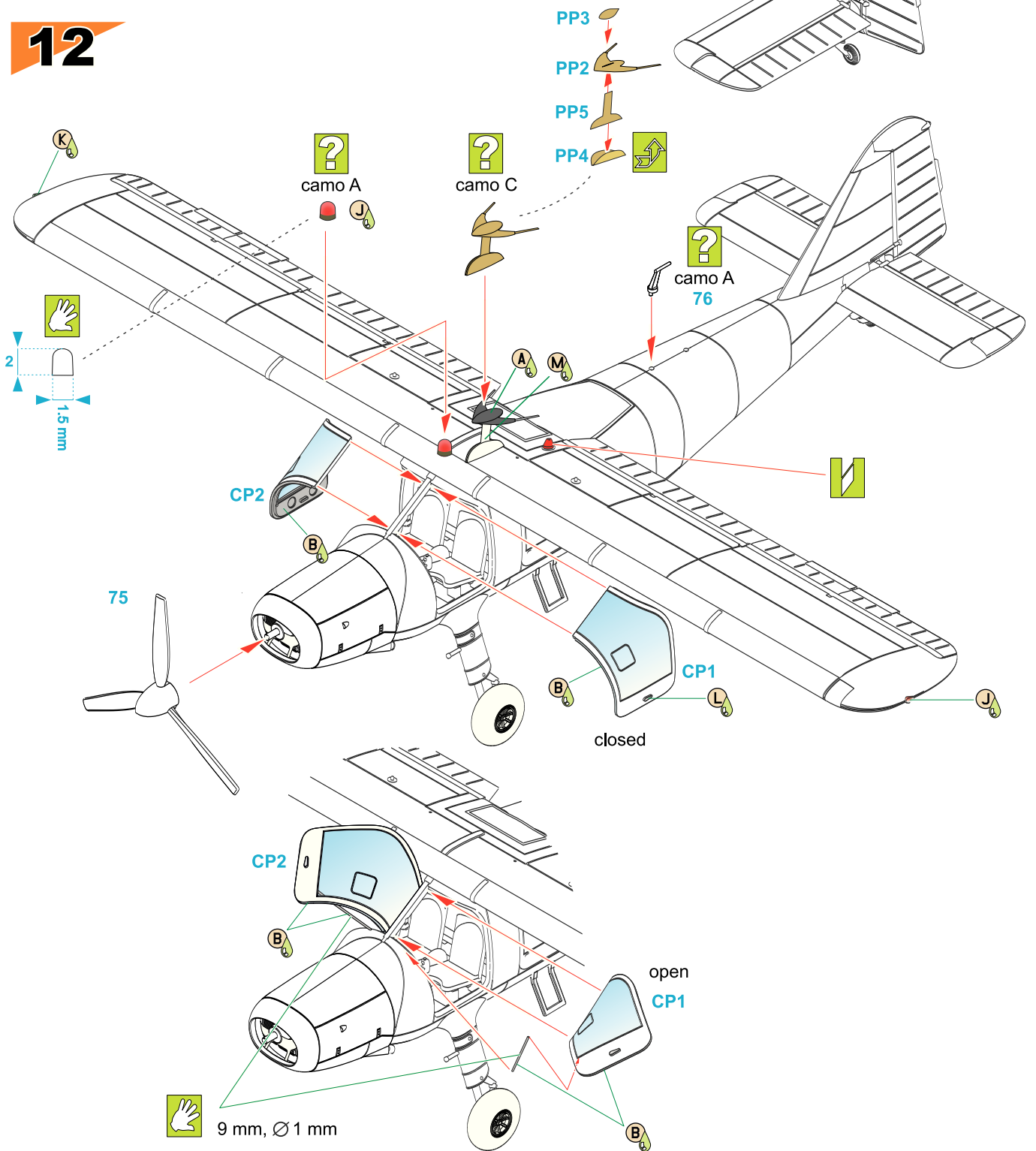

Dornier Do 27 H-2, V-607, Swiss Air Force (SAF), 1958–2008. V-607 was one of a total of seven Do 27s acquired for the SAF. The machine was delivered with special high altitude reconnaissance equipment and remained in service the longest of all Swiss Do 27s. Now it is displayed at the Flieger Flab Museum in Dübendorf.

Dornier Do 27 H-2, V-607, Švýcarské letectvo (SAF), 1958–2008. V-607 byl jedním ze sedmi Do 27 zakoupených SAF. Byl dodán se speciálním vybavením pro výškové průzkumné lety a používán nejdéle ze všech Do 27 SAF. Nyní je vystaven ve Flieger Flab Museum v Dübendorfu.

Scheme A

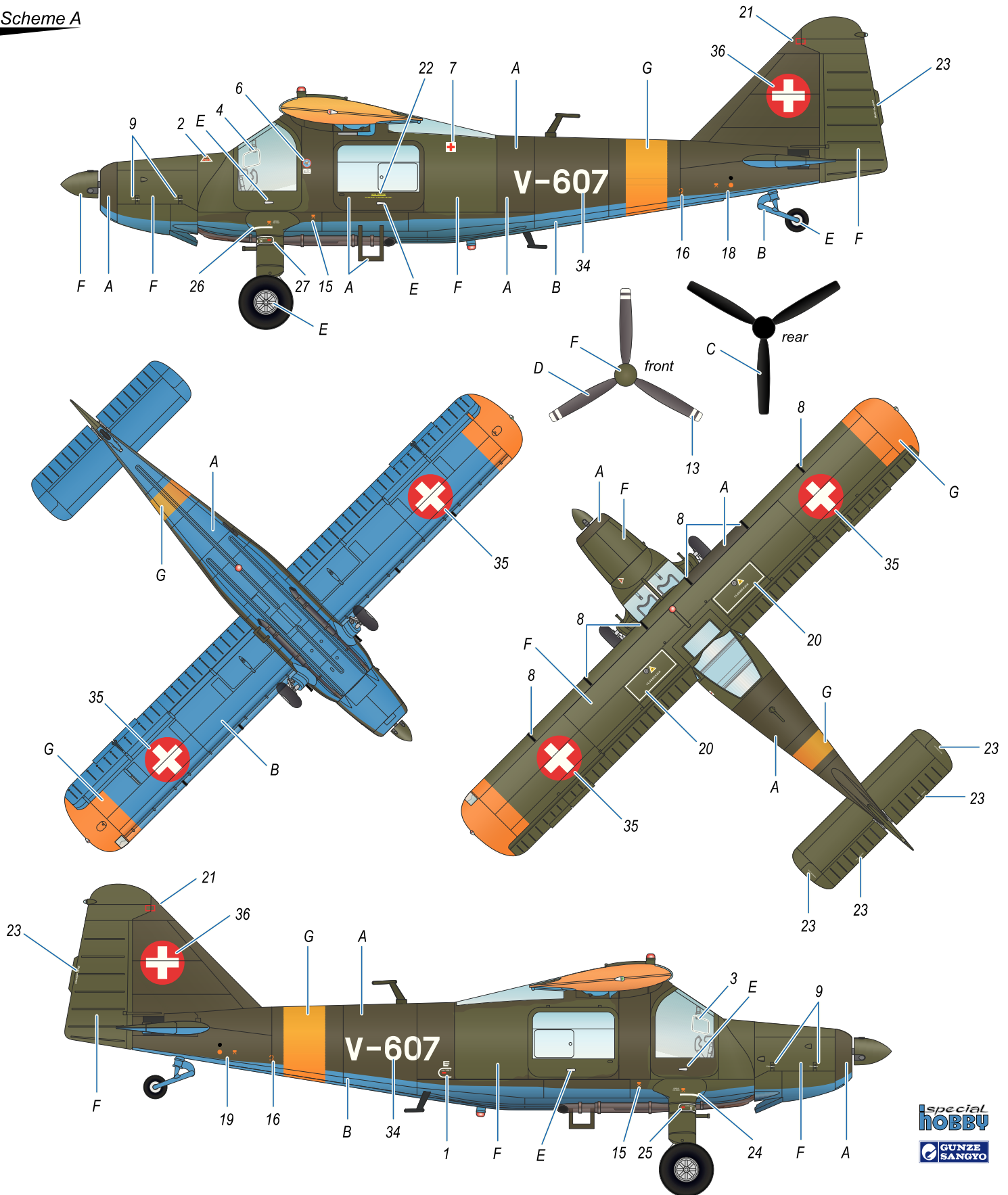

- | | | | | | | |
|---|--|------------------------------------|---------------------------------|--|---|--|
| A Olive Yellow (Brownish)
olivově žlutá
Gelboliv
H/C340 | B Light Blue
světle modrá
Hellblau
H25/C34 | C Black
černá
H12/C33 | D Gray
šedá
H/C317 | E Aluminium
hliníková
H/8 | F Olive Yellow (Greenish)
olivově žlutá
H/C340 | G Dayglo oranžová
Dayglo Orange
Leuchtorange
H/C98 |
|---|--|------------------------------------|---------------------------------|--|---|--|

Dornier Do 27 H-2, 10293 (Wr.N. 2142), one of two Do 27H-2s and three Do 27B-1s that the Turkish Army Air Force (Türk Kara Ordusu Havacılığı) acquired between 1964–65.

Dornier Do 27 H-2, 10293 (Wr.N. 2142), jeden z dvou Do 27H-2 a tří Do 27B-1, které Turecké armádní letectvo (Türk Kara Ordusu Havacılığı) zakoupilo v letech 1964–65.

Scheme B

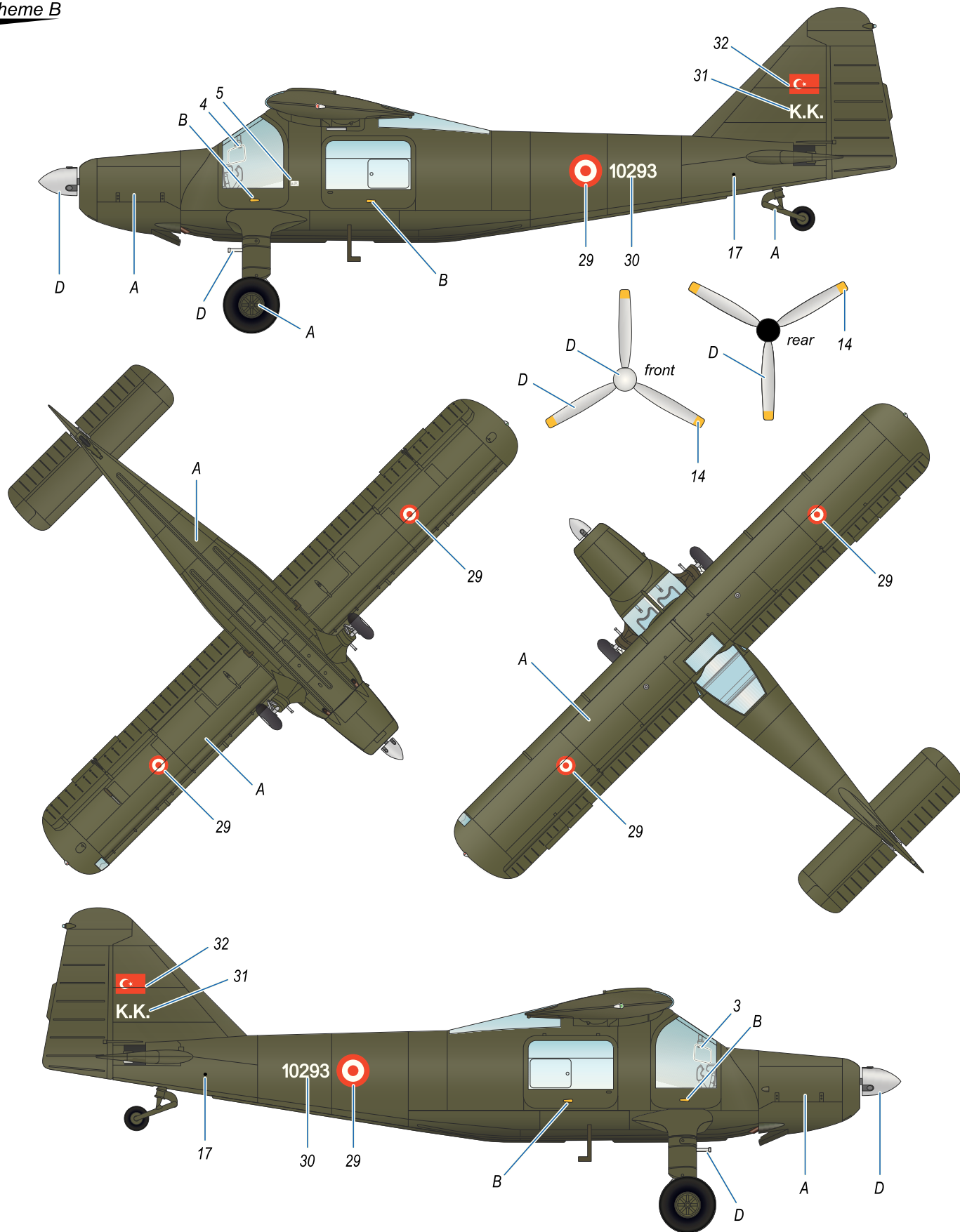

- | | | | | | | | |
|----------|--|----------|-------------------------|----------|---------------------------|----------|--------------------------------|
| A | Olive Yellow
olivově žlutá
Gelboliv
H340/C340 | B | Yellow
žlutá
H/C4 | C | Black
černá
H12/C33 | D | Aluminium
hliníková
H/C8 |
|----------|--|----------|-------------------------|----------|---------------------------|----------|--------------------------------|



Dornier Do 27 H-2, D-EDFS (Wr.N. 2006), still flying, privately owned aircraft, Germany.

Dornier Do 27 H-2, D-EDFS (Wr.N. 2006), dosud létající stroj soukromého majitele, Německo.

Scheme C

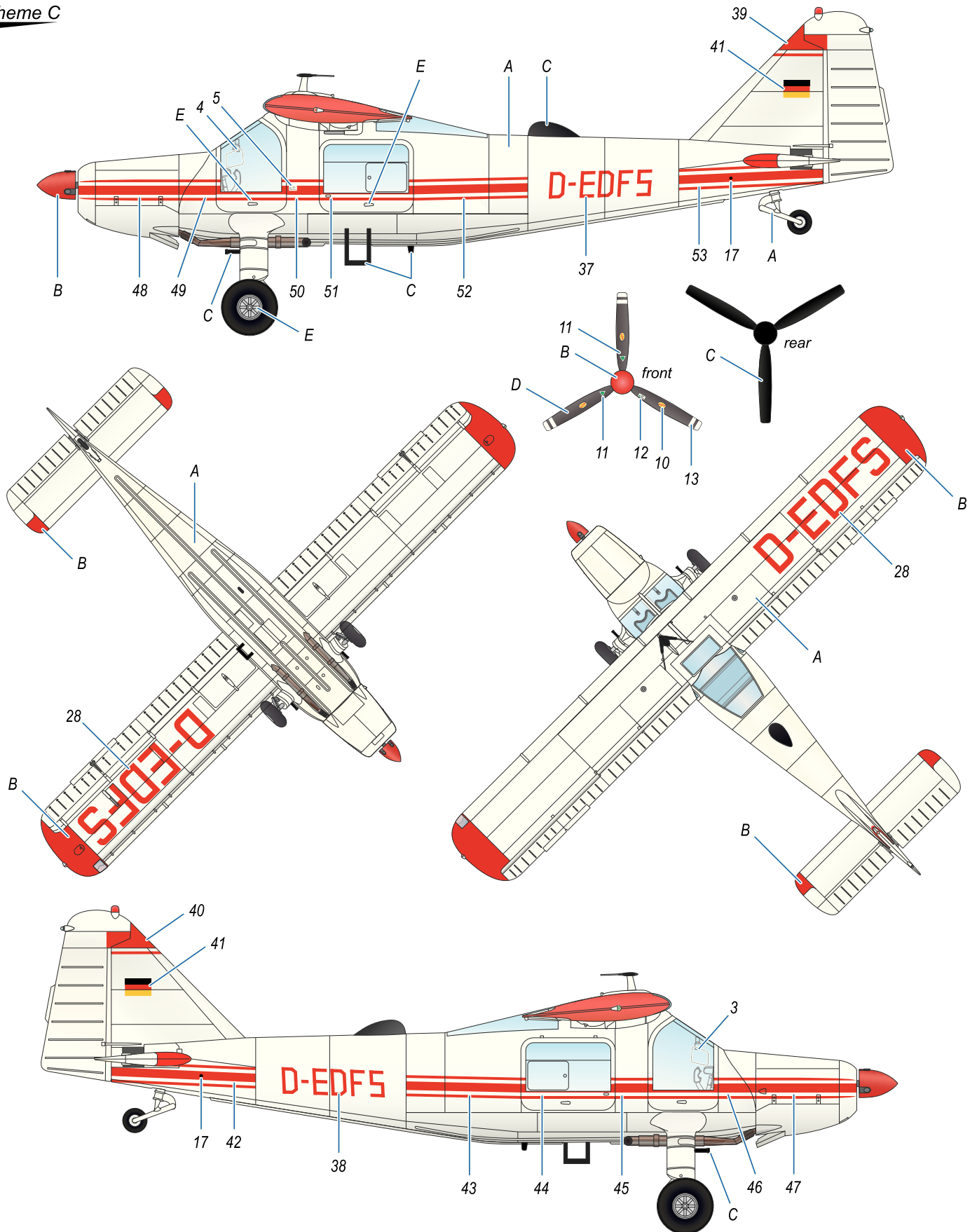

- | | | | | | | | | | |
|----------|-----------------------|----------|------------------------|----------|---------------------------|----------|------------------------|----------|--------------------------------|
| A | White
bílá
H/C1 | B | Red
červená
H/C3 | C | Black
černá
H12/C33 | D | Gray
šedá
H/C317 | E | Aluminium
hliníková
H/C8 |
|----------|-----------------------|----------|------------------------|----------|---------------------------|----------|------------------------|----------|--------------------------------|



Pre-cut mask set M72028 (sold separately) is a great help in painting the canopy frames and undercarriage wheels tyres. Get yours, too!

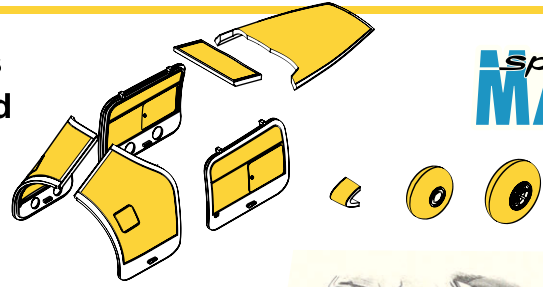

**Special
MASK**

Special Hobby offer for 1/72 Dornier Do 27 kits these resin sets and figures.



7410
Dornier Do-27
Control Surface set

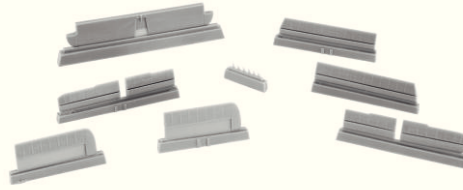

7411
Dornier Do-27
Cockpit set

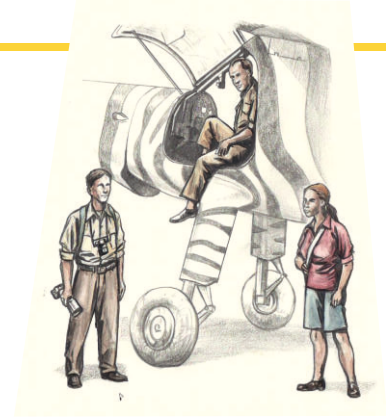

F72348
Do-27 Civilian Crew (pilot,
photographer with two cameras,
woman zoologist) 3 figures



1/72 SH72510

F-84F Thunderstreak 'Luftwaffe' HI-TECH



1/72 SH72490

Fouga CM.170 Magister 'Aerobatic Teams'

1/72 SH72523



**SMB-2 Super Mystere
'The First French Supersonic'**

1/72 SH72437



A.W. Meteor NF Mk.11 'RAF Squadrons'

1/72
SH72427



**AH-1G
Cobra
'Early Tails'**