

PEGASUS

Lancaster House, P.O. Box 50,
Whitstable, Kent, CT5 2UX, GREAT BRITAIN

Fokker D.XXIII

CONSTRUCTION NOTES

1. Firstly separate all parts from Sprues, and clean off all Flash & Moulding marks.
2. Locate Cockpit Floor moulding, and attach the Seat, Next attach the Instrument Panel to the port fuselage half. Add the Fuel Tank to the scribed portion of the floor, when dry add the metal Nosewheel compartment. underneath (Metal parts may be attached with any 'Cyano-Acrylate' adhesive such as Superglue).
3. Add the completed Cockpit assembly to the PORT Fuselage half, when dry join Fuselage halves and remove the joint line.
4. At this point add the Nose & Tail Cowlings to the front & rear of the Fuselage. When dry add the metal Propellers.
5. Next, join together the upper and lower Wing & Tail Boom mouldings, When dry add the Wings to the fillets on the Fuselage checking the dihedral angle with the general arrangement drawing on the reverse of the box. When dry add the Twin Booms & Tailplane mouldings. (The slots on the Fin should point inwards).
6. Invert model and attach the U/C Legs & U/C Doors, when dry add the Main Wheels, and the Under Fins to the slots in the bottom of the Booms.
7. Locate and attach the Canopy moulding. Finally, paint model in accordance with the Colouring Notes, and add the transfers.



PEGASUS

Lancaster House, P.O. Box 50,
Whitstable, Kent, CT5 2UX, GREAT BRITAIN

Fokker D.XXIII

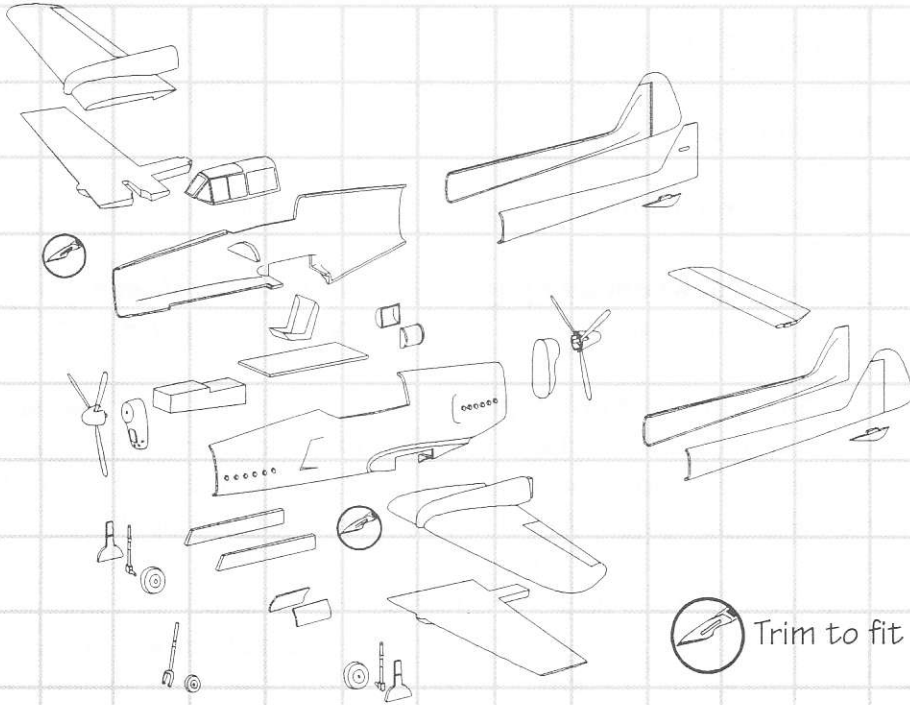

 Trim to fit

| COLOUR | METHUEN | FEDERAL STANDARDS | HUMBROL |
|-------------|---------|-------------------|---------|
| Roodbruin | 9E6 | F520076 | 133 |
| Zandkleurig | 5D5 | F520219 | 118 |
| Olijfgroen | 29F5 | F524159 | 114 |
| Zwart | N/A | N/A | 22 |
| Zwarte | N/A | N/A | 33 |

All colour values are approximate. 'Xtracolor' is the registered trade name of Messrs. Hannants of Lowestoft.

COLOURING NOTES & DECAL APPLICATION.

The Fokker D.XXIII depicted in the main plan on the reverse of the box was the first prototype Wr Nr. 155 at the time of the application of Military markings in April 1940. The upper camouflage was the standard Dutch three colour disruptive scheme of Zandkleurig (Sand), Olijfgroen (Olive Green), and Roodbruin (Red Brown), with all the undersurfaces, wheel wells, U/C etc. in Roodbruin. For some of the flight testing White bands edged in Black were carried, although it is not clear just how long these were employed for. The standard Black edged Orange National Markings were carried in six positions, with the Rudders being similarly finished. (Note: It is not known for certain if these markings were carried on the inside surfaces as well). The White call sign 998 was carried on the outer surfaces of the Booms. The propeller blades were Black, with the cockpit in medium Grey. A study of contemporary photographs indicates that the camouflage pattern had a tightly sprayed soft edge, and the whole airframe had an 'eggshell' finish. Weathering was kept to a minimum. Our thanks are gratefully extended to the following people who assisted with the research for this kit: Han Krol, Henk Timmers, (Luchtvaart Hobby Shop), and Joe Gian Francesco for the original idea.



©

Kit No: 4005



PEGASUS

1:72

1750

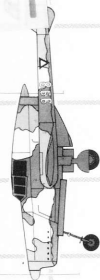

Fokker D.XXIII

Printed by R.G. LITHO
Whitstable Kent England

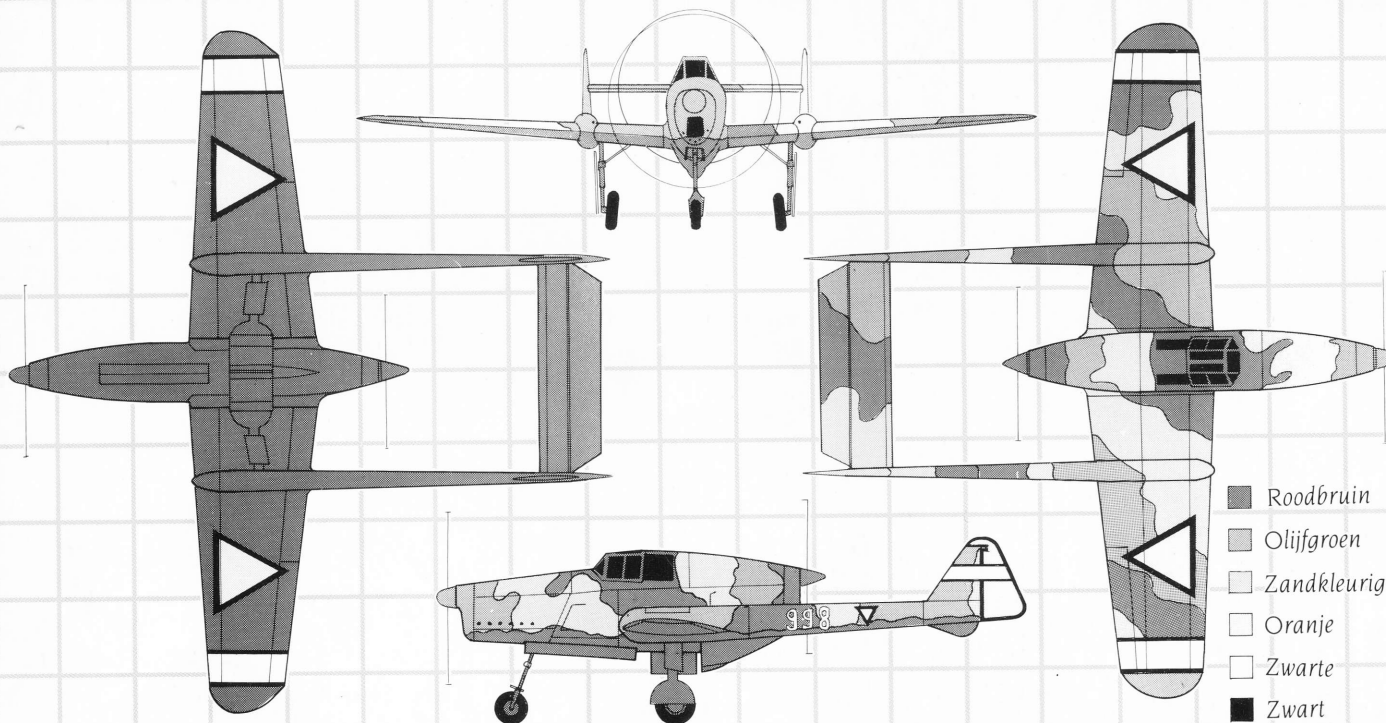

- Roodbruin
- Olijfgroen
- Zandkleurig
- Oranje
- Zwarte
- Zwart