

**RS**  
MODELS

**Dewoitine D-520**  
Francouzské stíhací letadlo - French fighter

SCALE  
1:72  
PLASTIC KIT

92090 92097  
92091 92101

The prototype flew for the first time on 2 October 1938 with Marcel Doret at the controls and the first production aircraft flew on 31 October 1939. By the time the German Blitzkrieg was launched only 50 D.520s were with front-line units. By 22 June 1940, 220 were in service. They did well in combat, claiming 77 definite victories against only 34 losses. Vichy units included four Groupes de Chasse and two Aeronavale escadilles in North Africa. Production restarted for a period by Vichy and then resumed under German supervision. Vichy D.520s fought in Syria and in North Africa during the Allied landings. 75 went to the Regia Aeronautica and 100 to Bulgaria, where they flew with the 6th Fighter Regiment. Final operations were with the Free French Groupe Doret against German pockets of resistance in France from November 1944 to May 1945. Post-World War II, a few were converted as D.520 DC two-seat dual-control trainers. Powered by a supercharged 678kW Hispano-Suiza 12Y45 engine, the D.520 was armed with an engine-mounted HS-404 20mm cannon and four wing-mounted 7.5mm MAC machine-guns.

Prototyp D.520 poprvé vzletl 2. října 1938 pilotován Marcellem Doretem a první sériový letoun D.520 vzletl koncem října 1939. Do vypuknutí války bylo k jednotkám dodáno jen 50 letadel, do 22. června celkem 220 ks. Během bojů zaznamenaly 77 vítězství při ztrátě 34 strojů. Po kapitulaci byly letouny dále používány letečtvem Vichy a po čase i obnovena výroba. Byly dodány i Bulharsku a Itálii, Vichy je používala během bojů v Africe a Sýrii. Posledního bojového nasazení se dočkaly po invazi u Svobodných Francouzů. Po válce bylo ještě 5 strojů přestavěno na cvičné dvojmístné. Dewoitine D.520 byla poháněna motorem HS-12Y45 o výkonu 860 k a vyzbrojena 20 mm kanonem HS-404 v ose vrtule a čtyřmi kulomety MAC 7,5 mm v křídle.

**Osádka / Crew:** 1 (pilot)  
**Rozpětí / Wingspan:** 10,25 m  
**Délka / Length:** 8,75 m  
**Výška / Height:** 2,6 m  
**Nosná plocha / Wing area:** 16 m<sup>2</sup>  
**Hmotnost prázdného stroje / Empty weight:** 2090 kg  
**Vzletová hmotnost / Take off weight:** 2670 kg  
**Pohonná jednotka / Powerplant:** Hispano-Suiza 12Y-45/ 690 kW  
**Maximální rychlost / Max. speed:** 537 km/h  
**Dolet / Range:** 1250 km  
**Dostup / Service ceiling:** 11 000 m

Díly - Parts

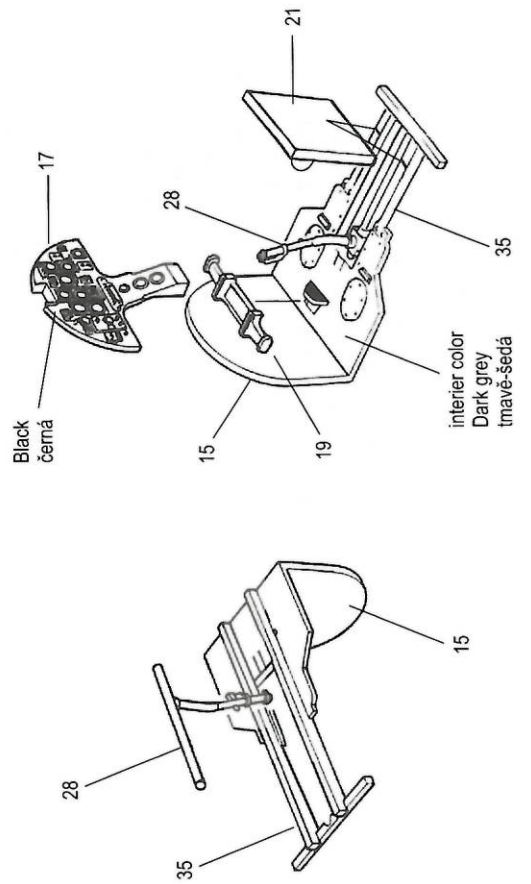
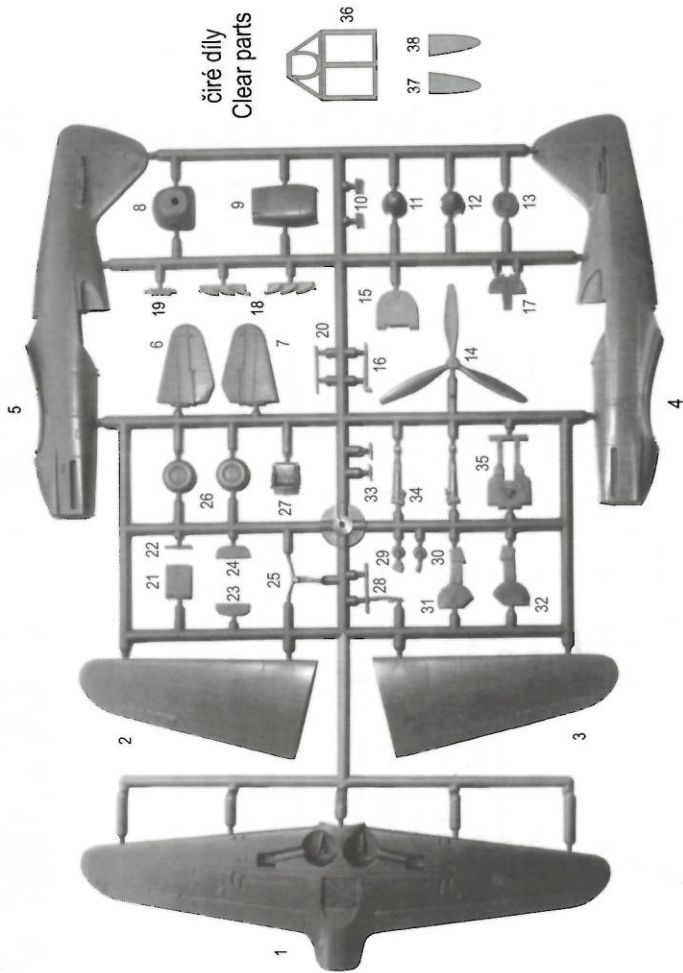

2

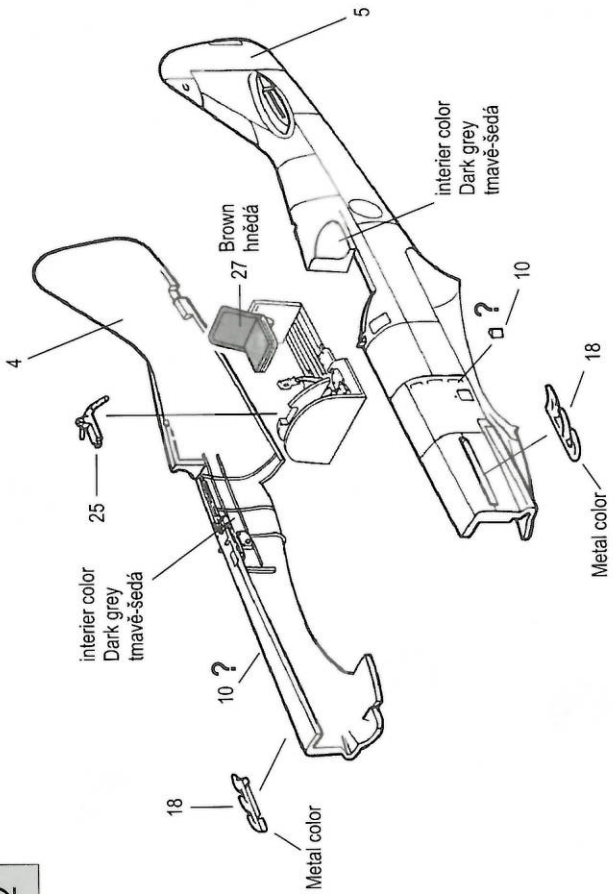

3

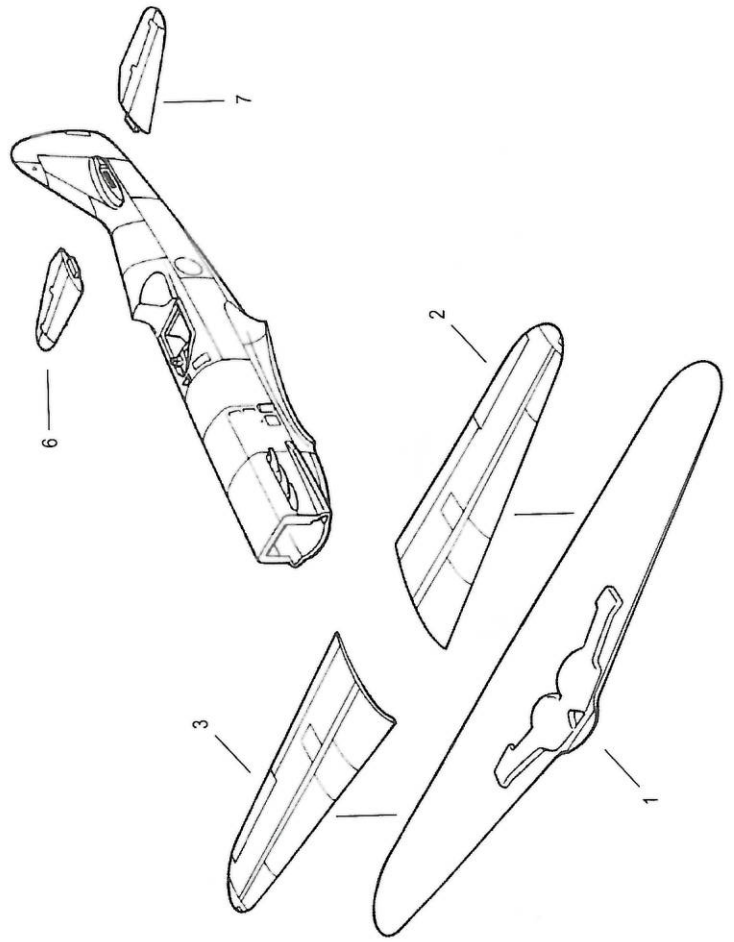

1



③ D.520, St. Martin-du-Touch, France 1941

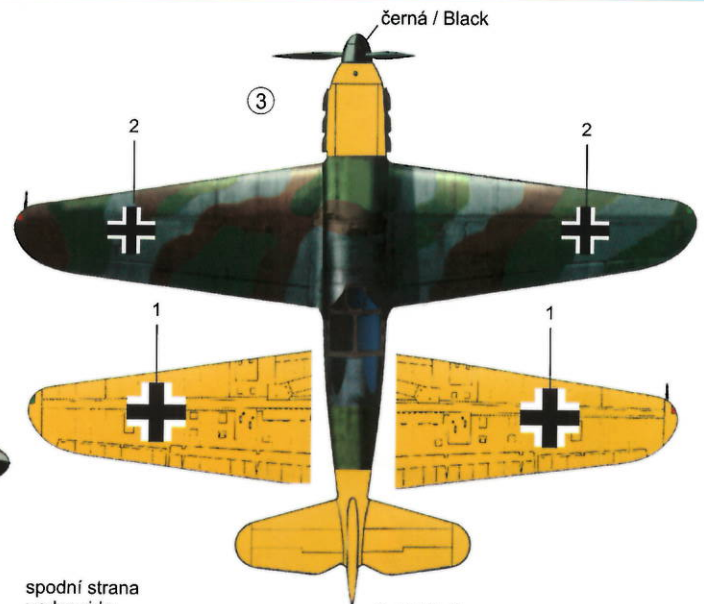
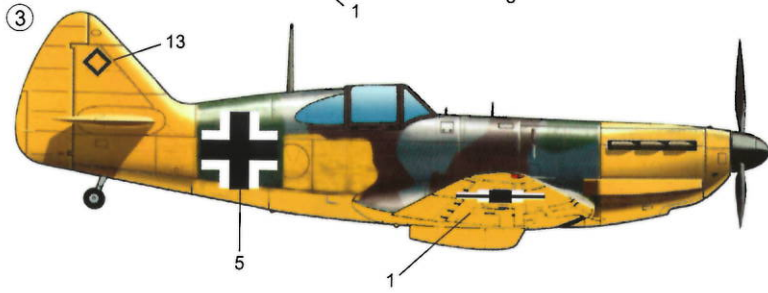
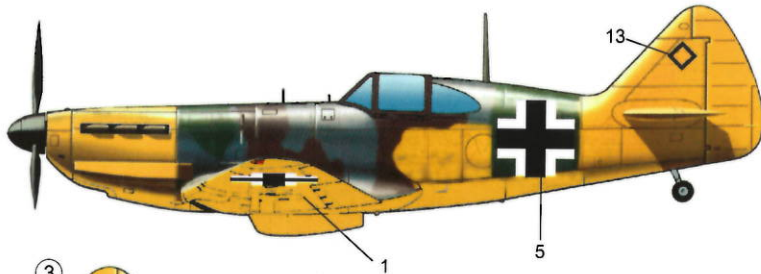

④ D.520 "1", 3 Esc. GC II/5, Lt. Pierre Villacéque, Casablanca, November 1942

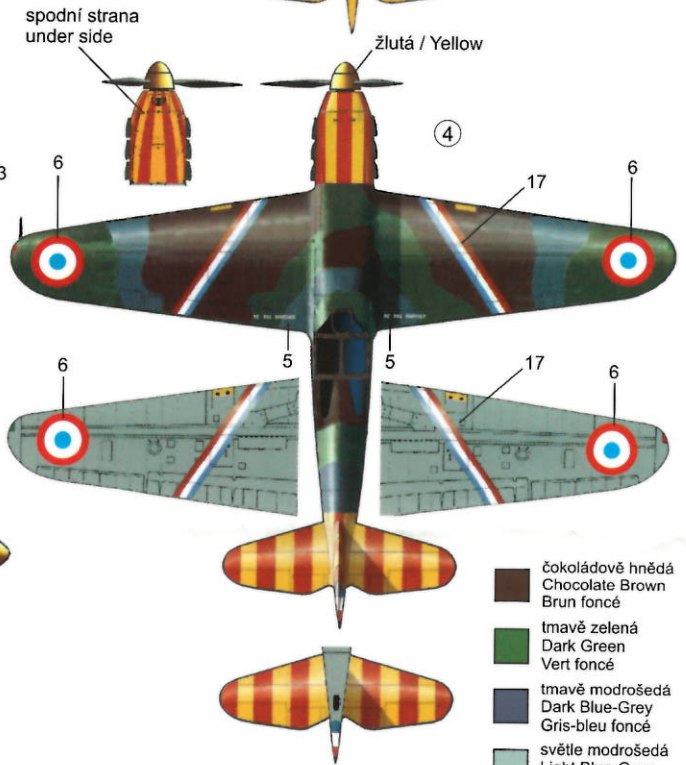
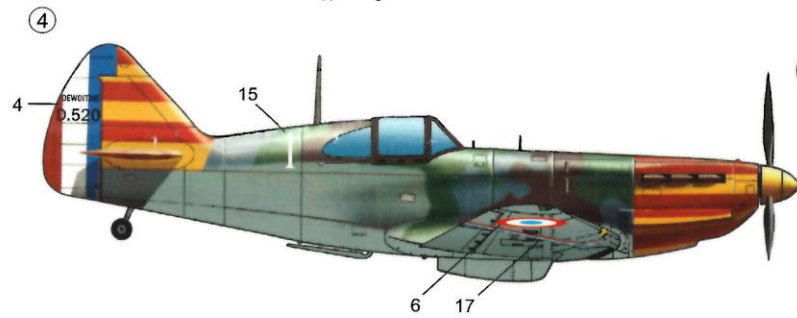
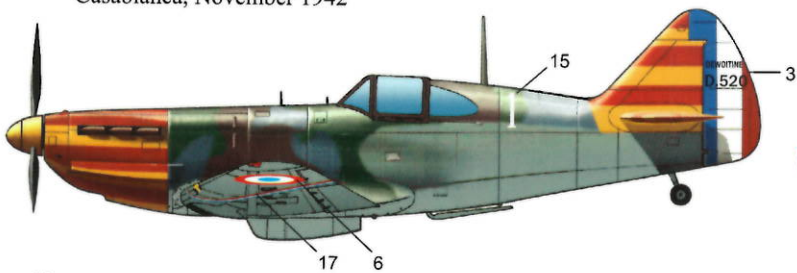

⑤ D.520, Factory airfield Toulouse-Francazal, 1943/44

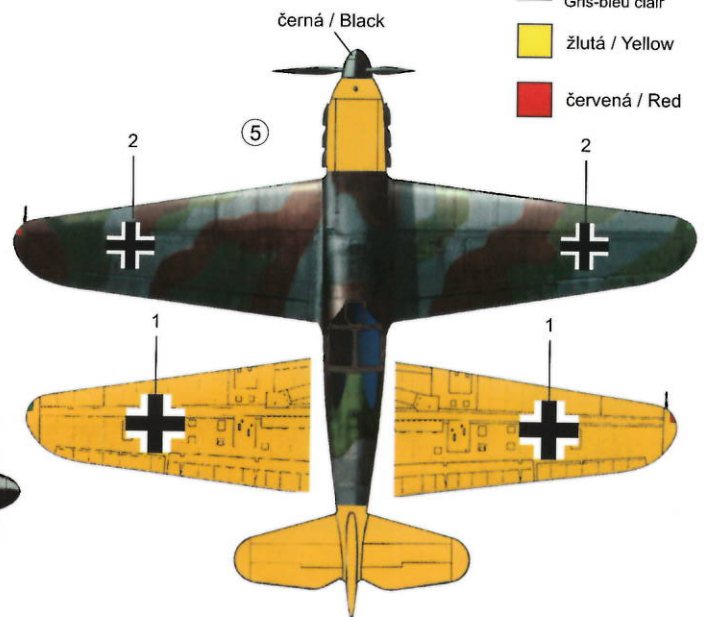
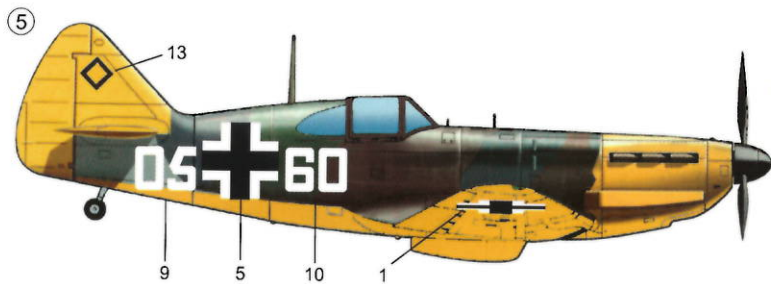
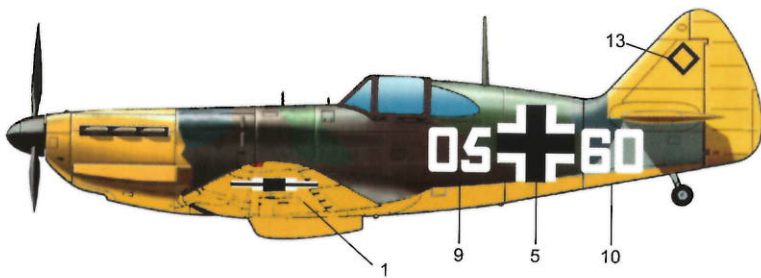

- čokoládově hnědá  
Chocolate Brown  
Brun foncé
- tmavě zelená  
Dark Green  
Vert foncé
- tmavě modrošedá  
Dark Blue-Grey  
Gris-bleu foncé
- světle modrošedá  
Light Blue-Grey  
Gris-bleu clair
- žlutá / Yellow
- červená / Red

další zbarvení pro model - next markings for model

**Dewoitine D-520**

[www.rsmodels.cz](http://www.rsmodels.cz)



**92097**



RS models  
U Lomu 7, 795 01 Rýmařov  
email: [rsmodels@rsmodels.cz](mailto:rsmodels@rsmodels.cz)  
Czech republic

1:72 SCALE AIRCRAFT SERIES



