

JAGDTIGER

Sd.Kfz.186

EARLY/LATE PRODUCTION

2IN1

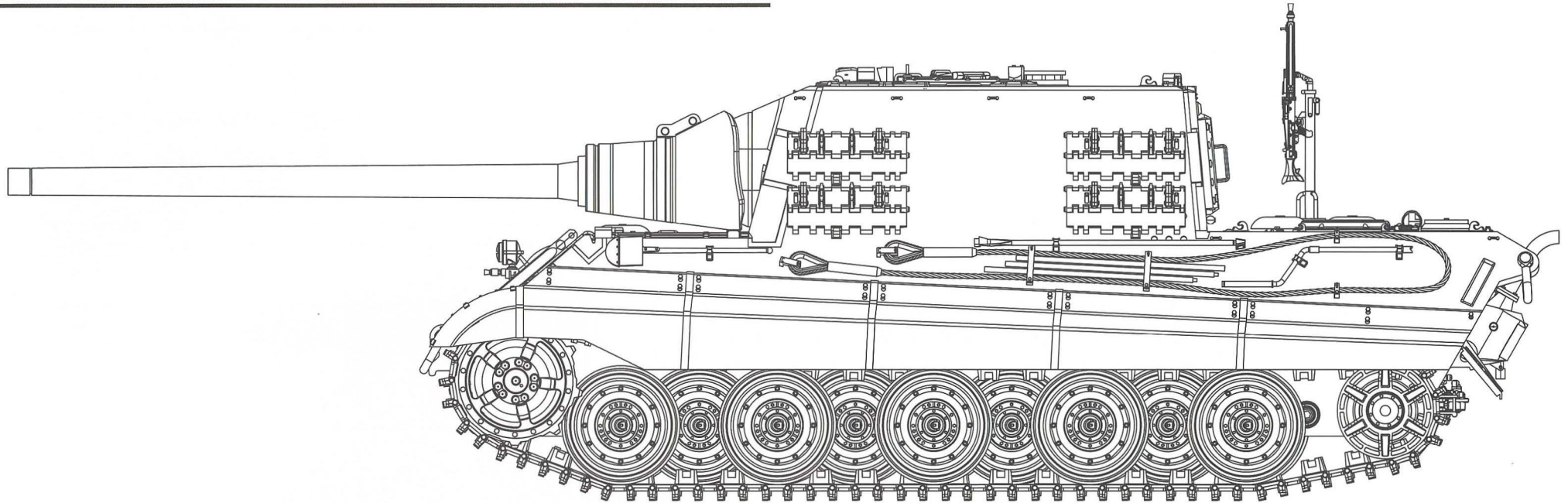

Based on the highly successful King Tiger, the 72-ton German Sd.Kfz.186 Panzerjäger Tiger Ausf. B, or Jagdtiger, was the ultimate operational German Tank Hunter of WW2.

Two prototypes were produced, one by Henschel and one by Porsche, mainly differing by their road wheel and suspension systems, with the Henschel suspension system being eventually chosen for series production. An order of 150 vehicles was placed, with production commencing at Nibelungenwerk in St. Valentin (Steyr-Daimler-Puch) in July 1944. Production was slow due to the cumbersome weight of the various elements of the vehicle, as well as the factory being targeted by Allied strategic bombing missions. Only around 80 examples were produced before the end of the war.

The Jagdtiger was armed with the most powerful anti-tank gun in the German arsenal during WW2, the Krupp 12.8 cm PaK 44 L/55, capable of out-ranging and defeating any Allied tank it could have faced. Additional armament consisted of a single Rheinmetall 7.92 mm MG 34 provided with a ball mount in the left side of the hull, and provisions for mounting another of these weapons externally on the engine deck for aerial defense. The main gun mount offered a very limited traverse of 10 degrees, so if targets were outside its field of fire, the entire tank had to be turned & re-aimed, causing considerable stress on the engine and often jarring the gun out of calibration..

The greatest weakness of the vehicle was its powerplant, the 690 hp V-12 Maybach HL 230 P30 gasoline engine. Straining under the heavy weight with high fuel consumption, the operational range was only some 120 km (75 miles) on-road, and 80 km (50 miles) off-road. The huge casemate featured 250 mm thick armor at the front, while the glacis plate featured the same 150 mm thickness as the King Tiger. This heavy armor added serious weight to the vehicle, and the engine proved significantly underpowered, resulting in a poor power-to-weight ratio. This resulted in strained components and caused low speed and poor off-road capability, as well as unreliability and inefficiency. These problems were so severe that most vehicles were lost due to these issues, rather than to enemy fire.

Serving on both the eastern and western fronts, only two heavy tank-hunter battalions received the vehicle. These were the 512th Heavy Panzerjager Battalion and the 653rd Heavy Panzerjager Battalion. About 20% of the Jagdtigers supplied to these units were lost due to fuel shortages and the vehicle's mechanical unreliability.

03.02.8001

READ BEFORE ASSEMBLY

CAUTION

- Read carefully and fully understand the instructions before commencing assembly. A supervising adult should also read the instructions if a child assembles the model.
- When assembling this kit, tools including knives used. Extra care should be taken to avoid personal injury.
- Keep out of reach of small children. Children must not be allowed to suck any part, or pull vinyl bag over their heads.



Optional



Do Not Cement



Remove



Be Careful



Drill



Instant Glue
for Metal



Fill Holes

PAINTS REQUIRED

Color info and profiles by Mig Jimenez

A.MIG-0032	Satin Black	A.MIG-0034	Rust Traks	A.MIG-0045	Gun Metal	A.MIG-0041	Dark Rust
A.MIG-0096	Crystal Periscope Green	A.MIG-0037	New Wood	A.MIG-0038	Light Wood	A.MIG-0010	RAL 7028 Dunkelgelb (mid war)
A.MIG-0001	RAL 6003 Olivgrun opt.1	A.MIG-0015	RAL 8017 Schokobraun	A.MIG-0036	Old Wood	A.MIG-0002	RAL 6003 Olivgrun opt.2
A.MIG-0014	RAL 8012 Rotbraun	A.MIG-0012	RAL 7028 Dunkelgelb Aus '44 DG III	A.MIG-0003	RAL 6011 Resedagrün	A.MIG-0011	RAL 7028 Dunkelgelb Aus '44 DG I
A.MIG-0004	RAL 6011 B Resedagrün						

APPLYING DECALS

1. Clean the model surface with a wet cloth.
2. Cut out each decal design from sheet, and dip it in tepid water for 15~20 sec.
3. Hold the backing sheet edge and slide decal onto the model.
4. Move decal into position by wetting decal with finger.
5. Press decal gently down with a soft cloth until excess water and air bubbles are gone.

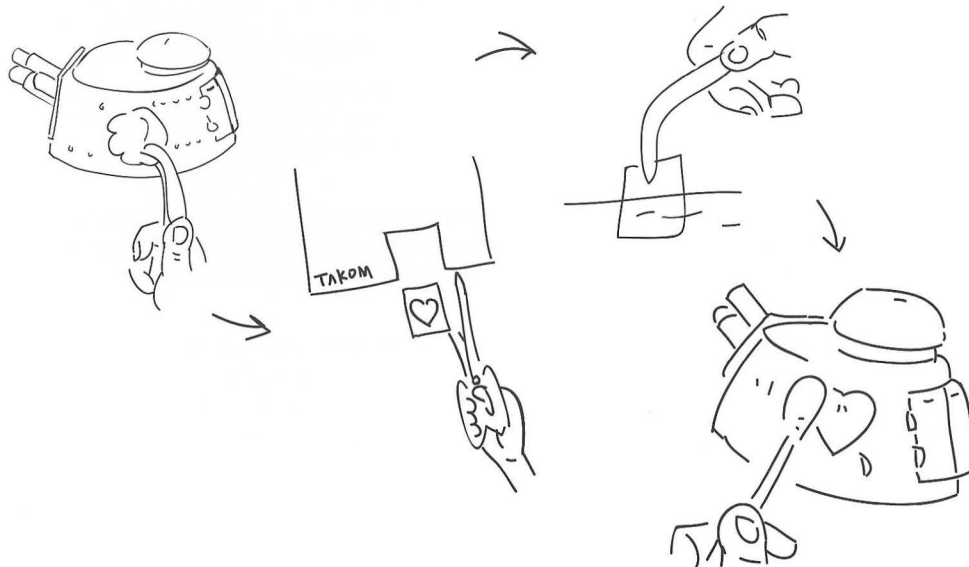

REMOVING PE

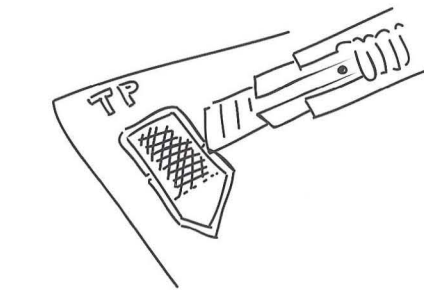

Be careful not to hurt when removing PE parts.

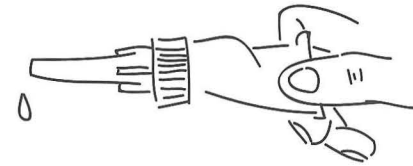

Secure using instant glue (not included).

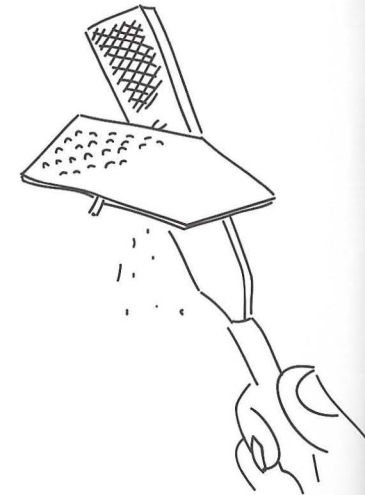

Finish using file.

PARTS

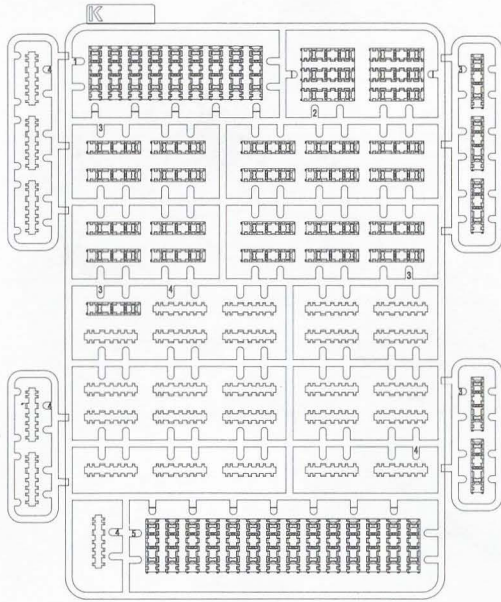

X2

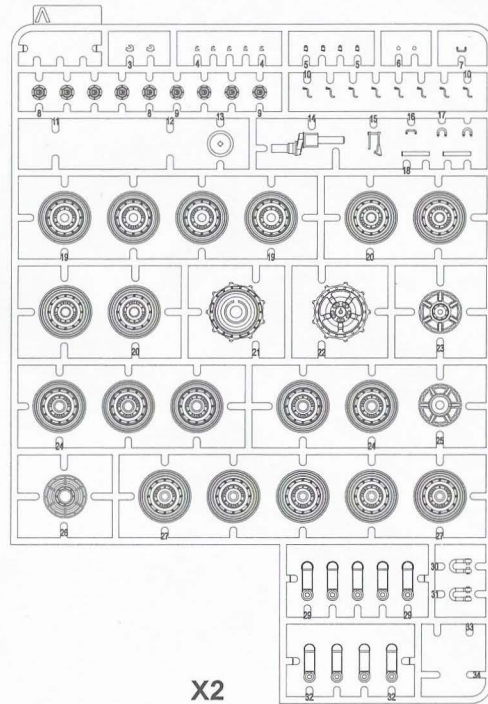
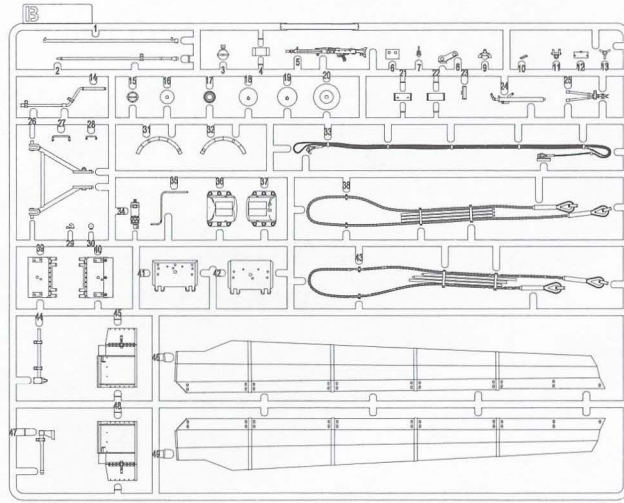

X2

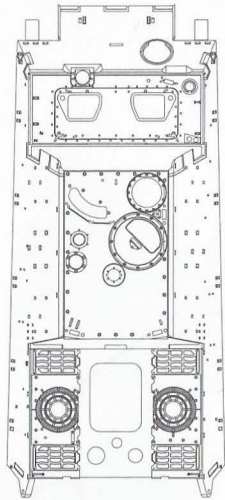

Upper Hull

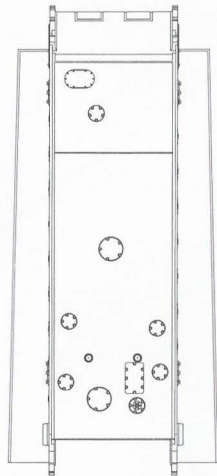

Lower Hull

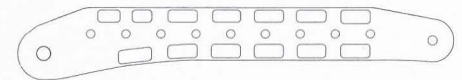
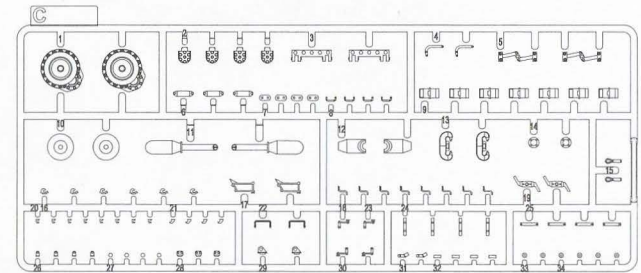
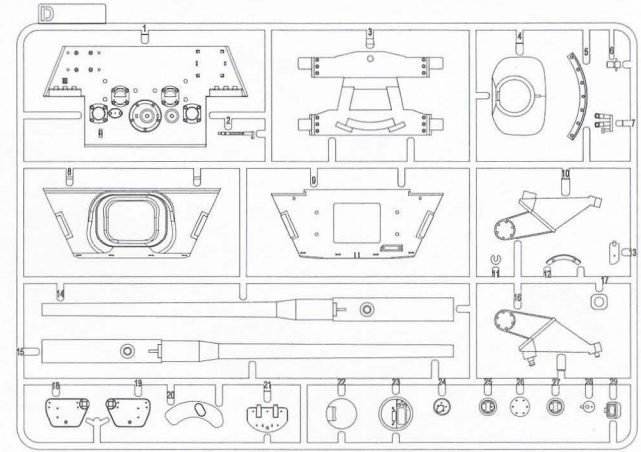
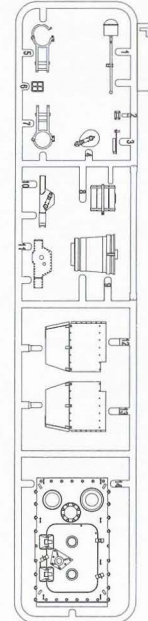
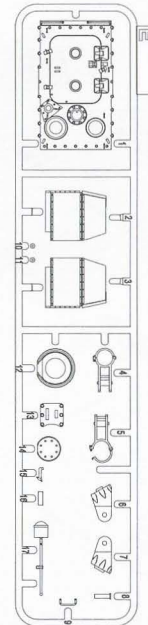

Z1

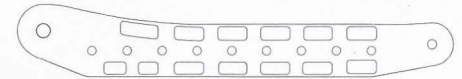

Z2



Cable



TP



Decal

1

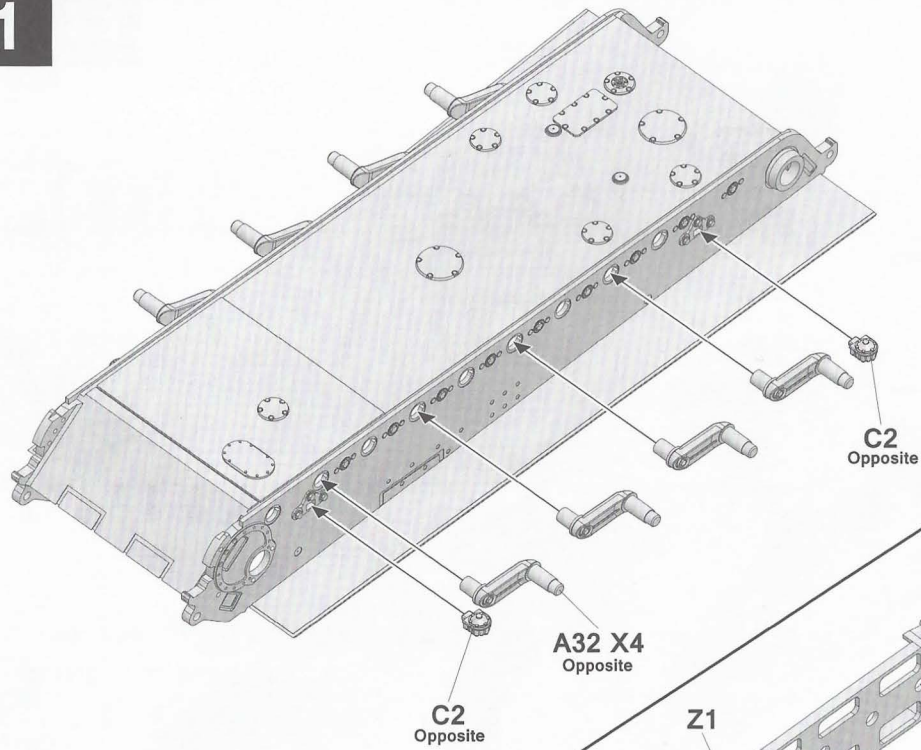

2

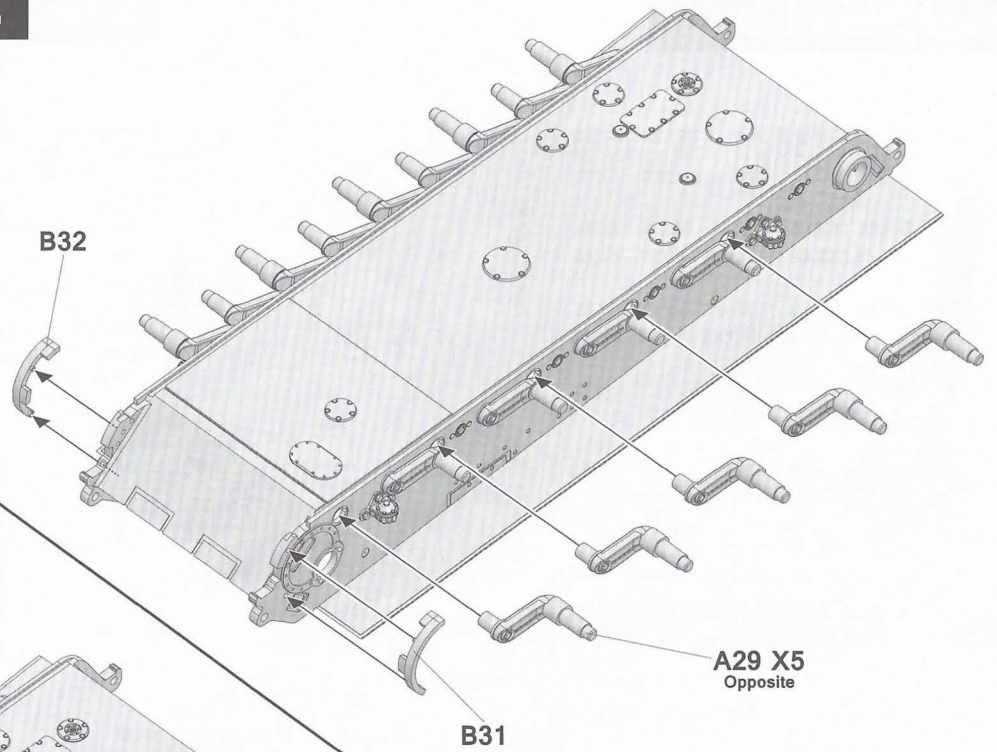

3

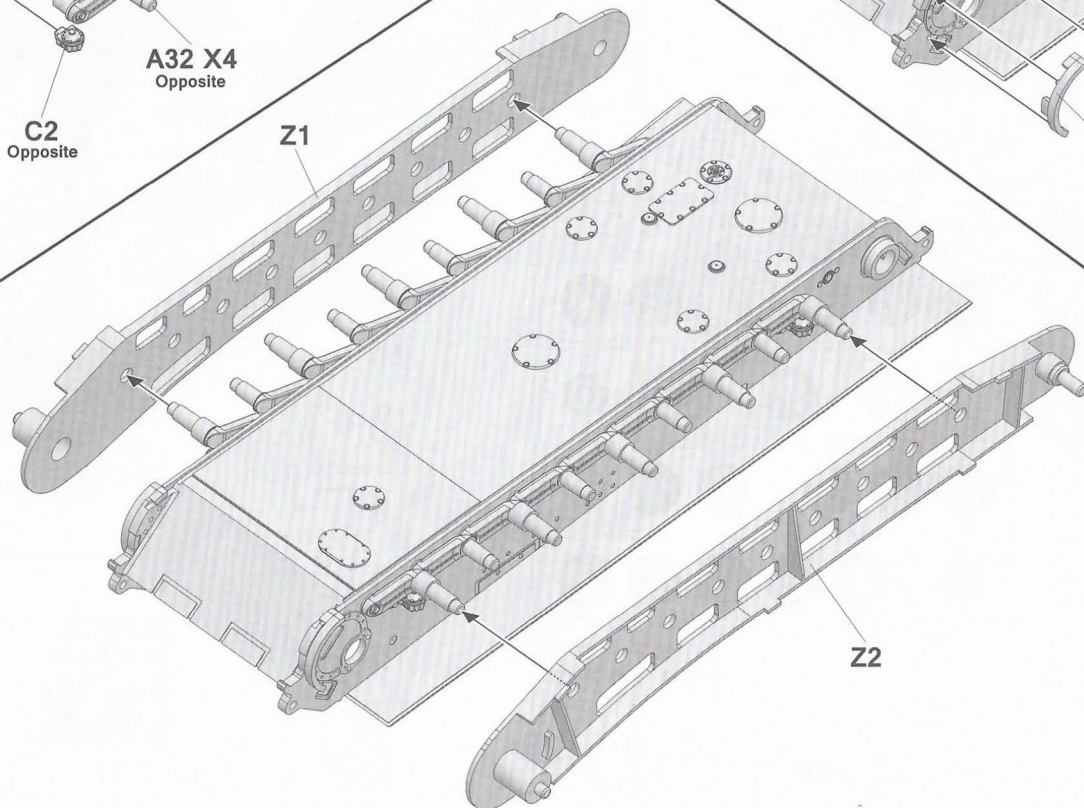

3

4

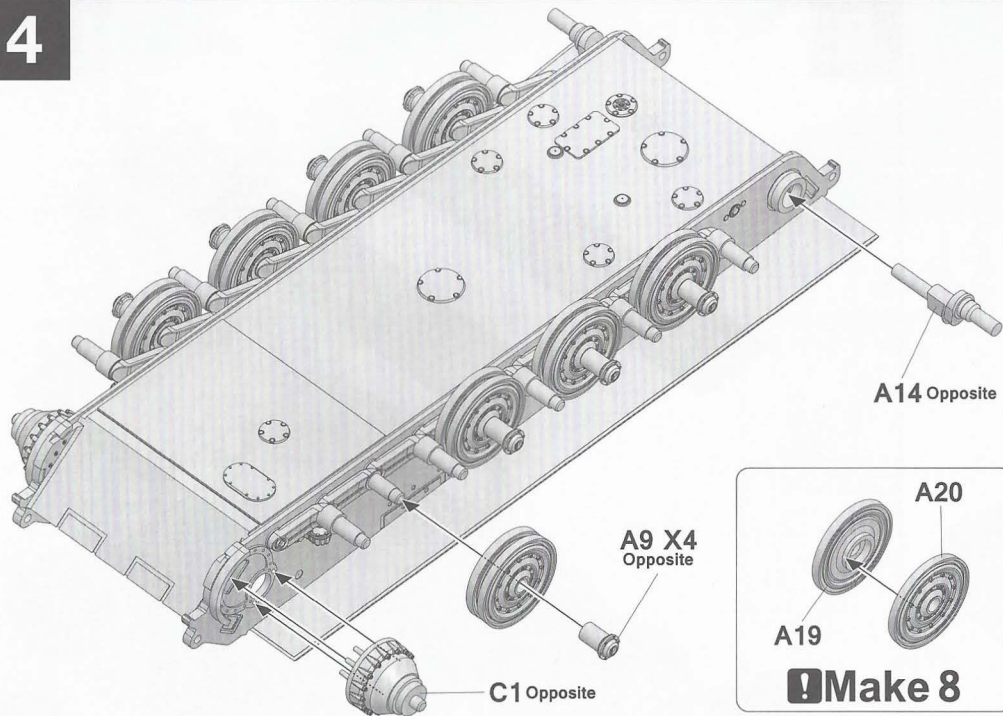

5

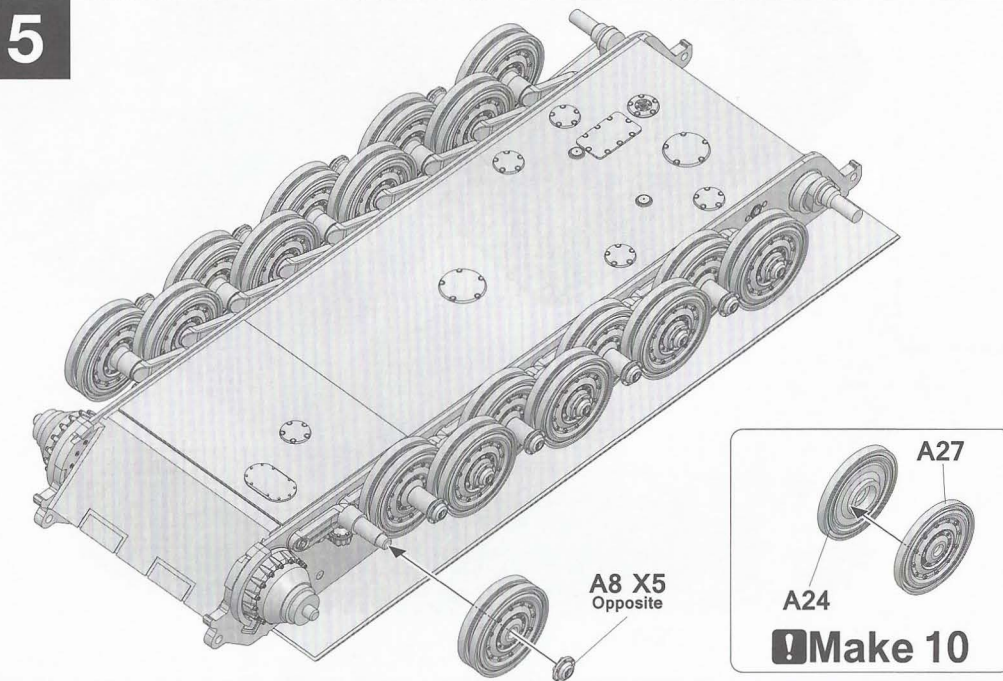

6

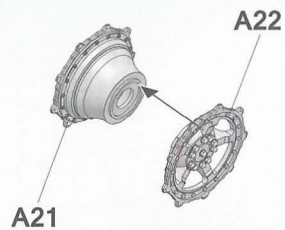

Make 2

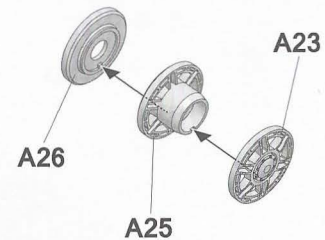

Make 2

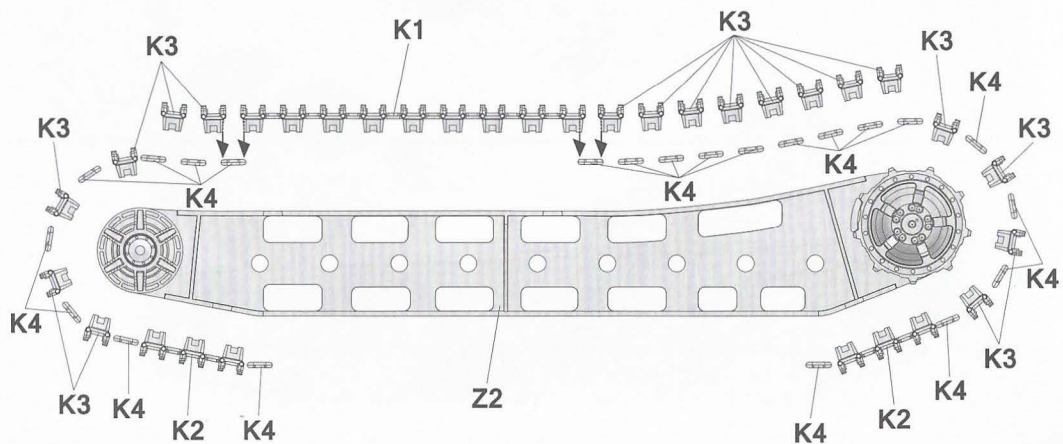
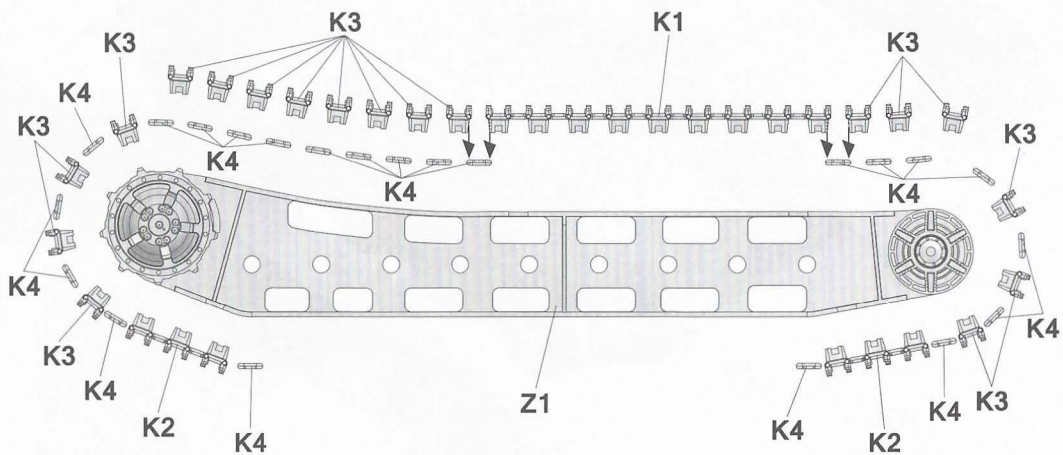

7

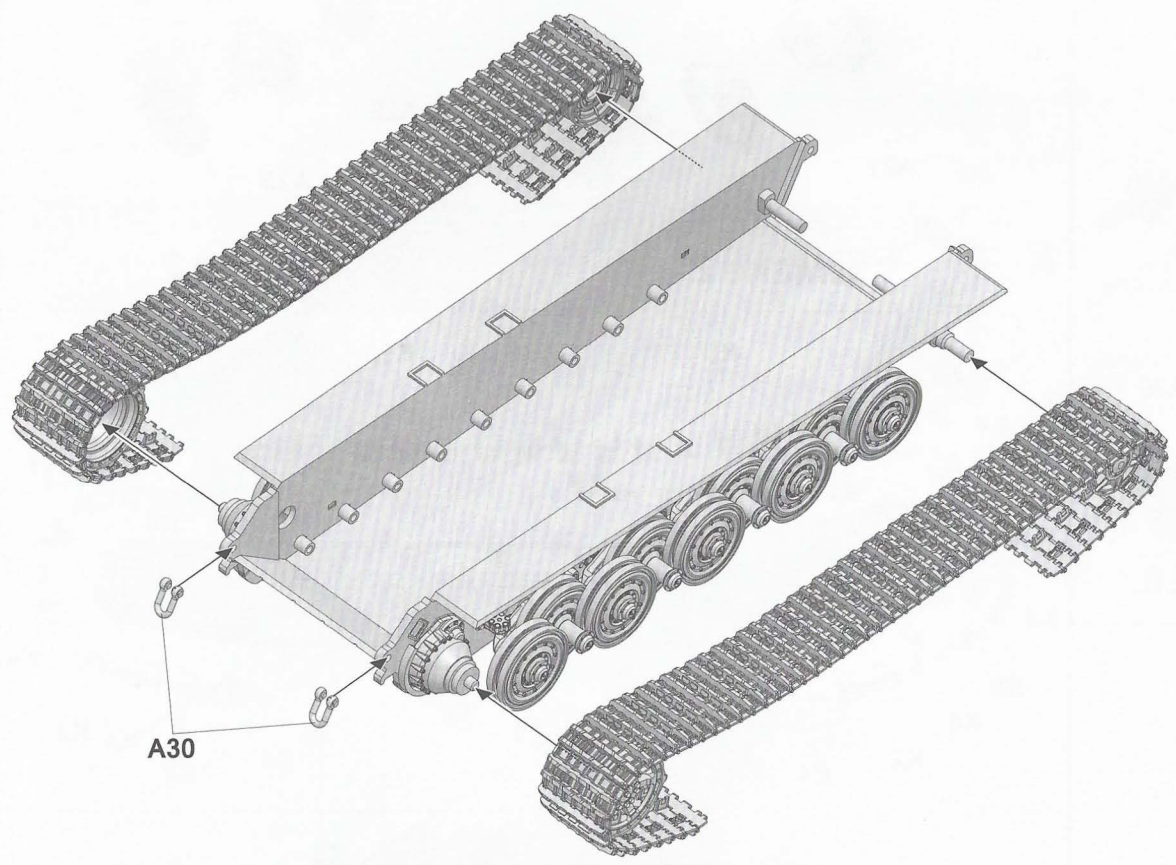

8

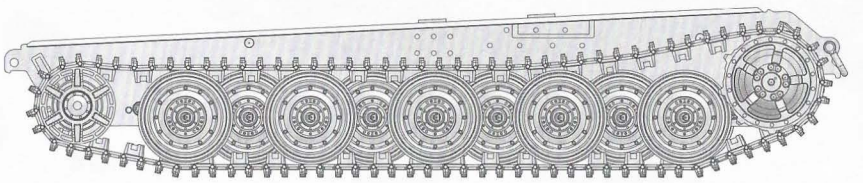
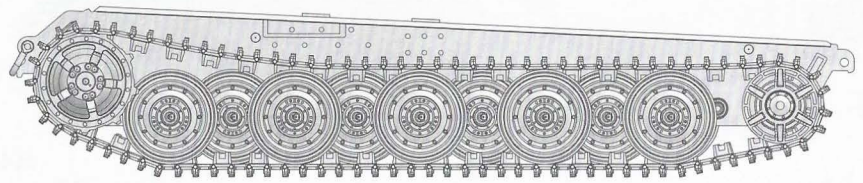
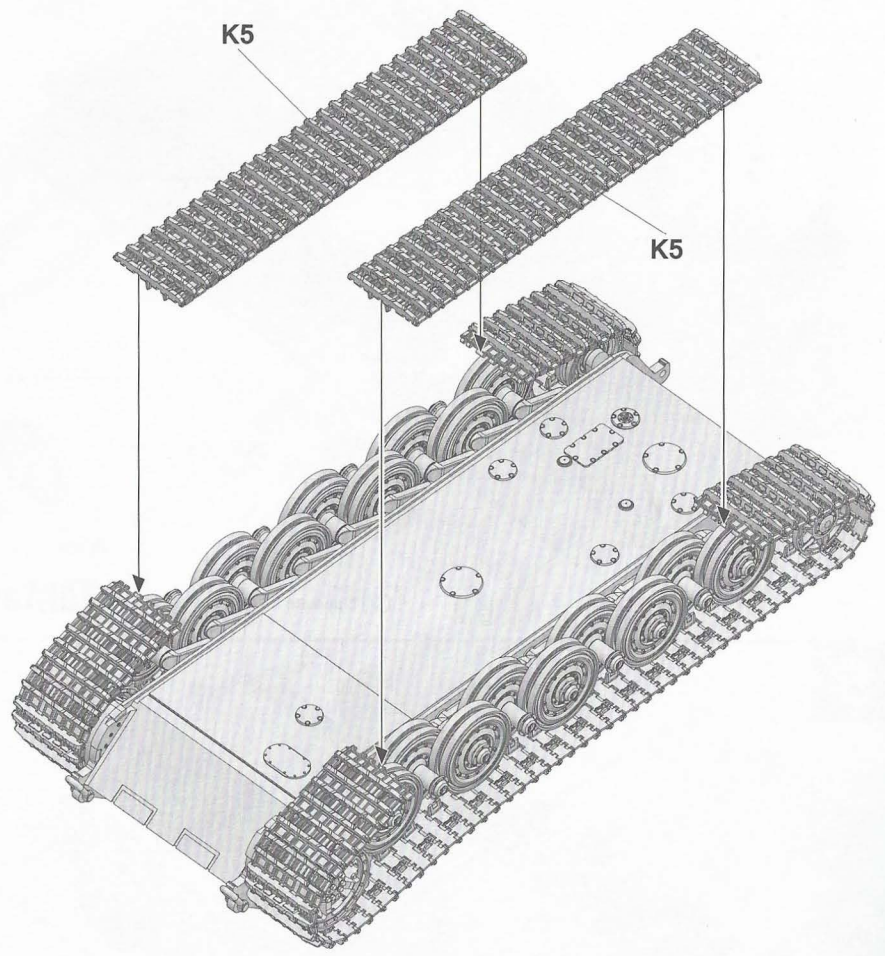

9-1

!
Early

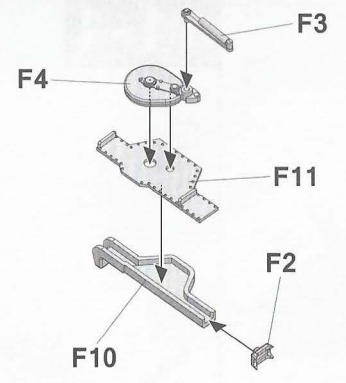
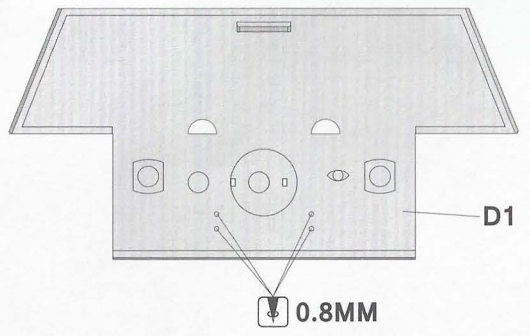

9-2

!
Late

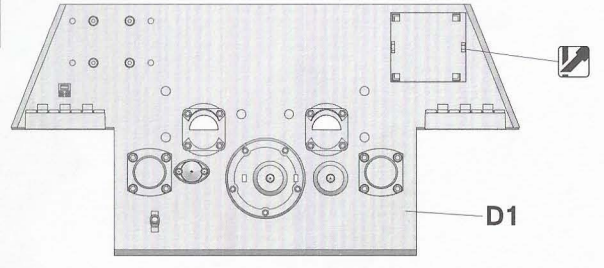

9-2 #8001

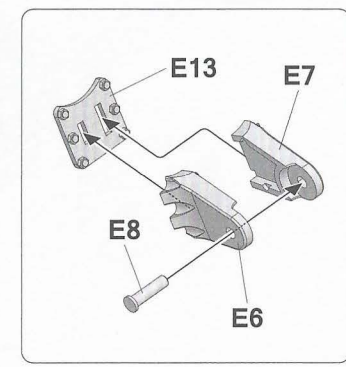
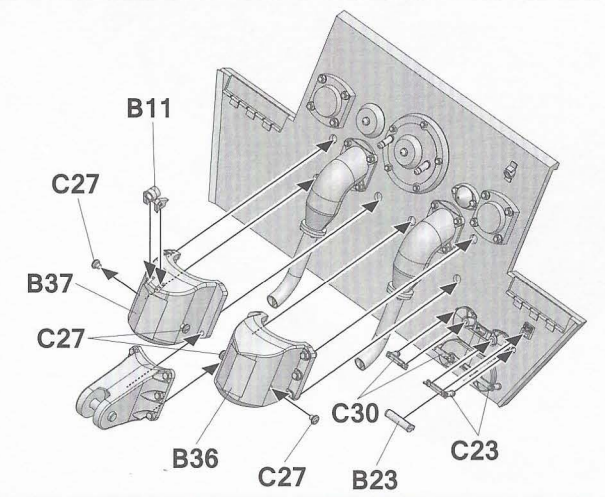
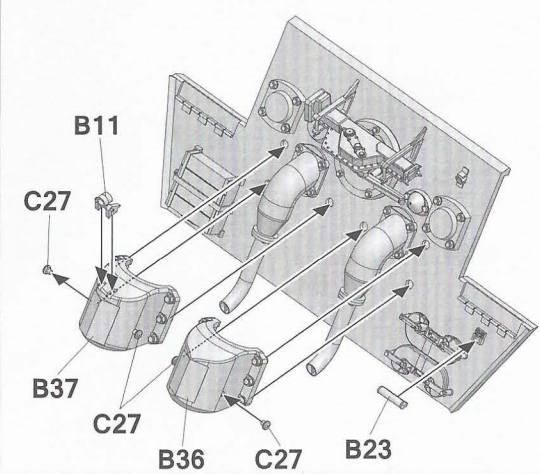
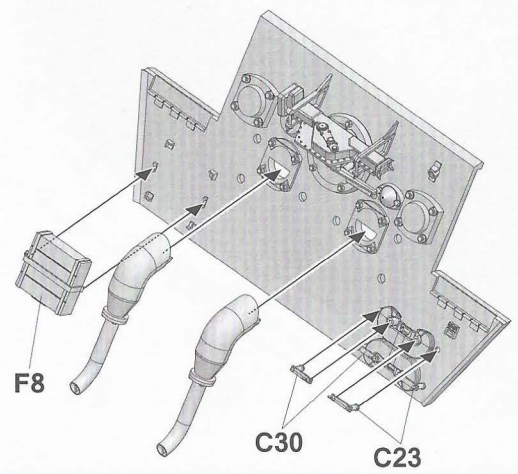
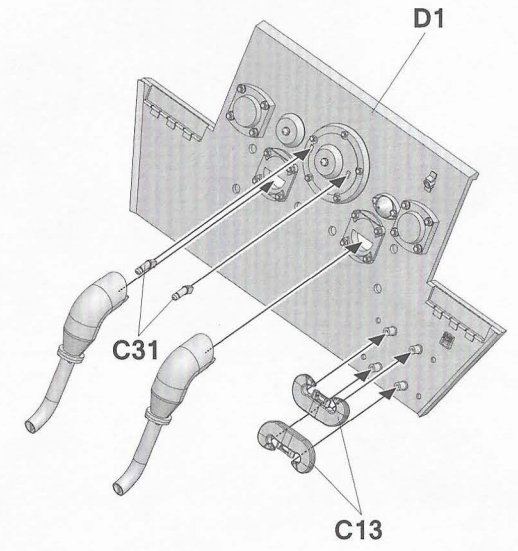
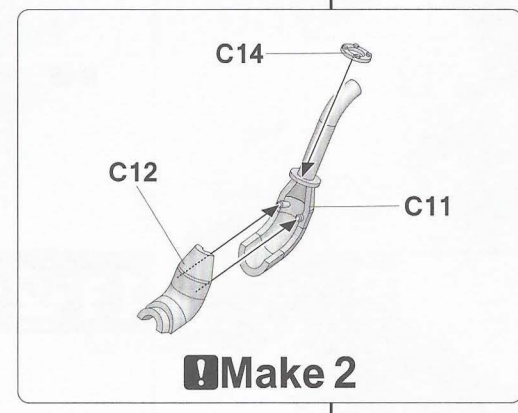
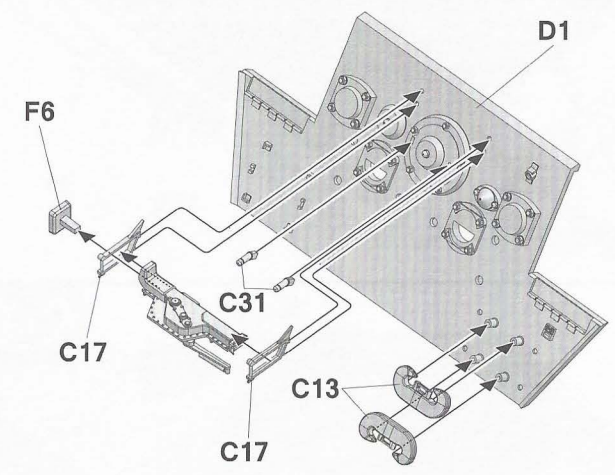
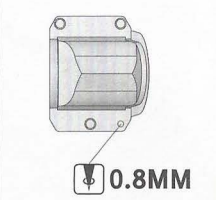
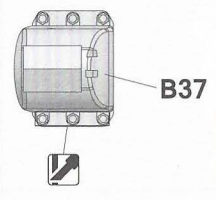
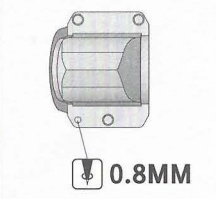

10

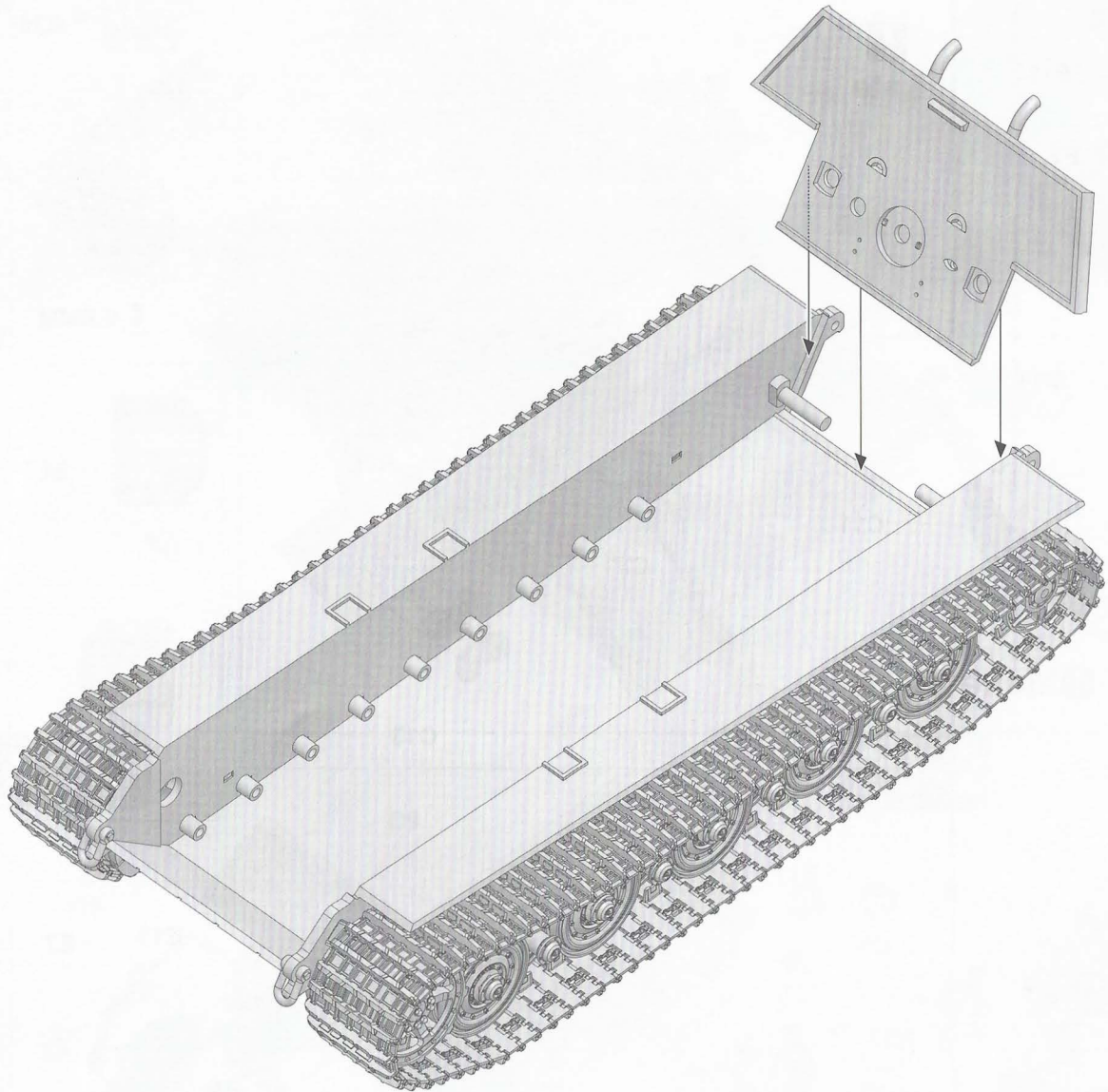

11-1

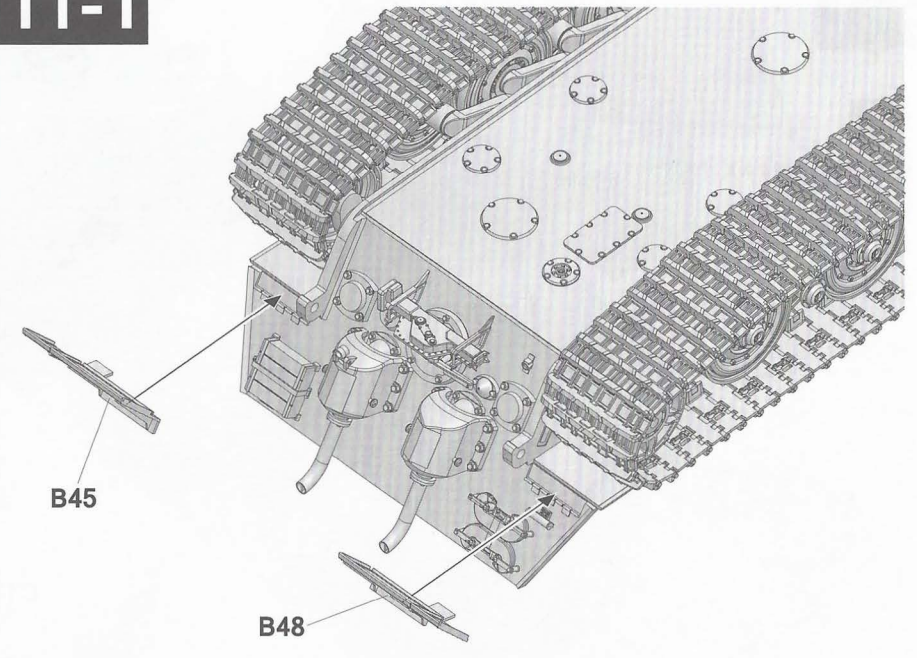

11-2

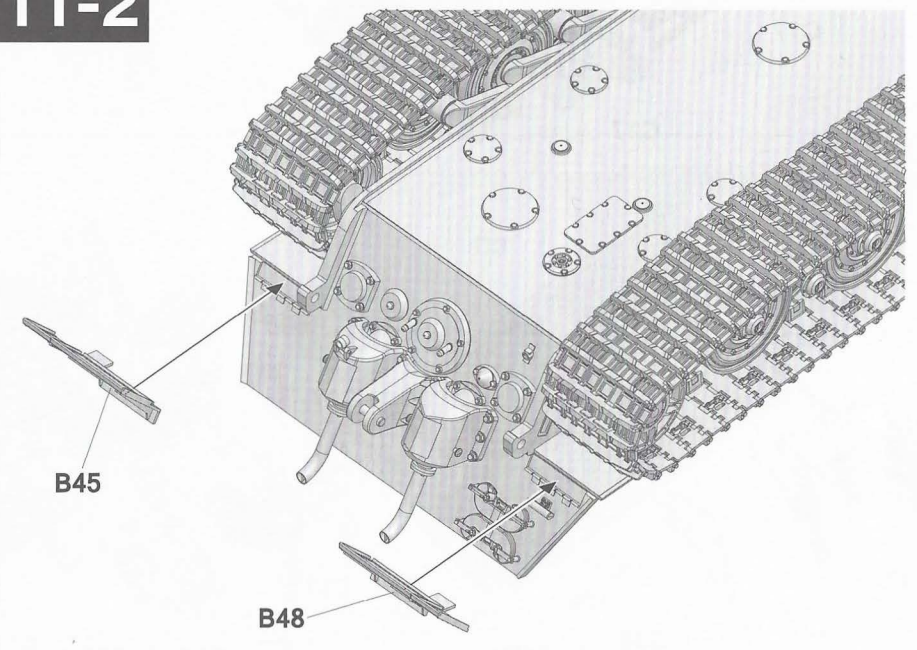

12-1

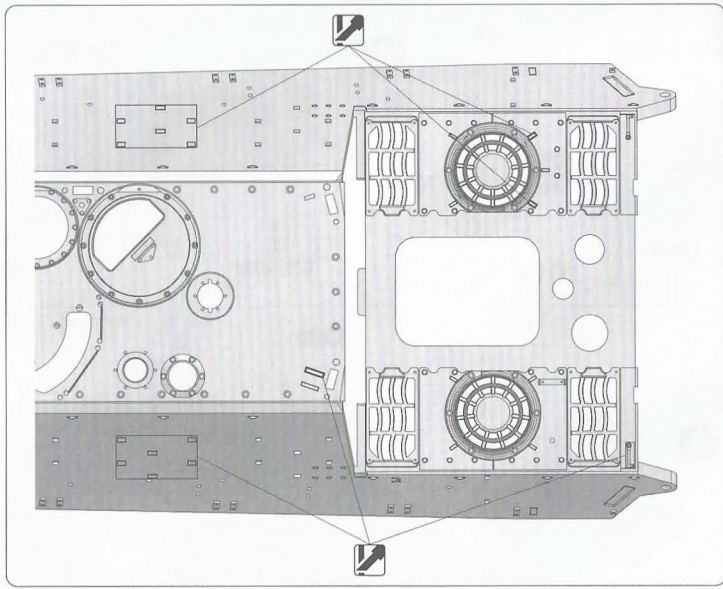

12-2

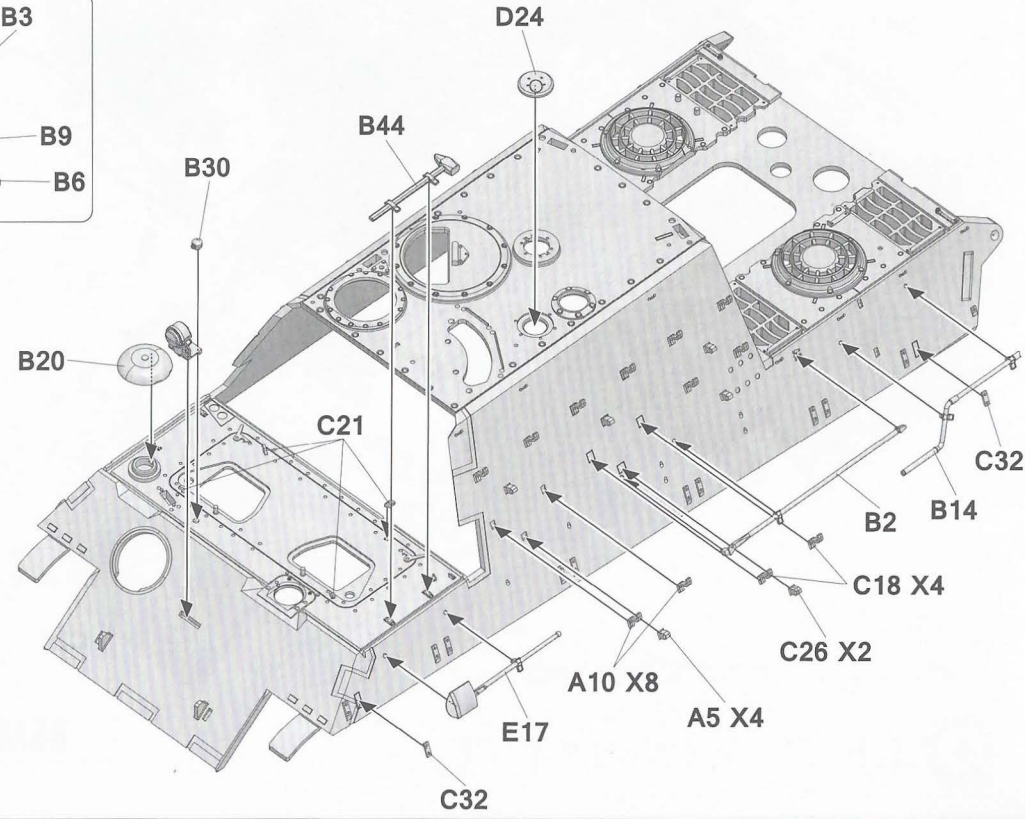
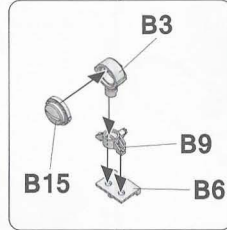
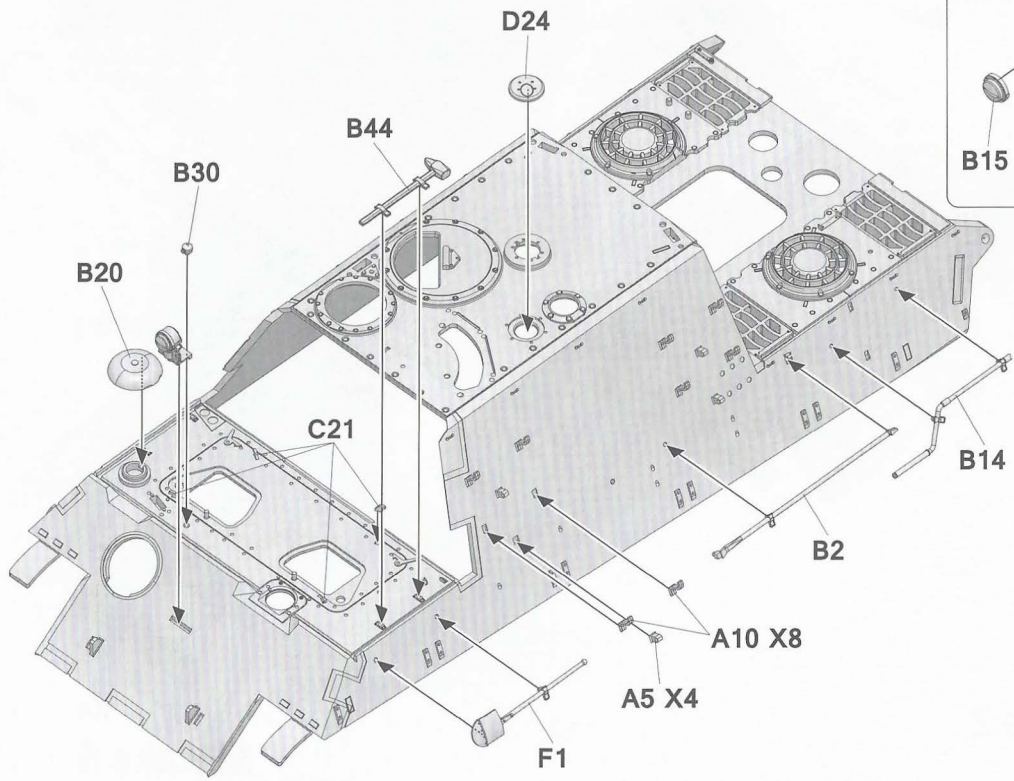
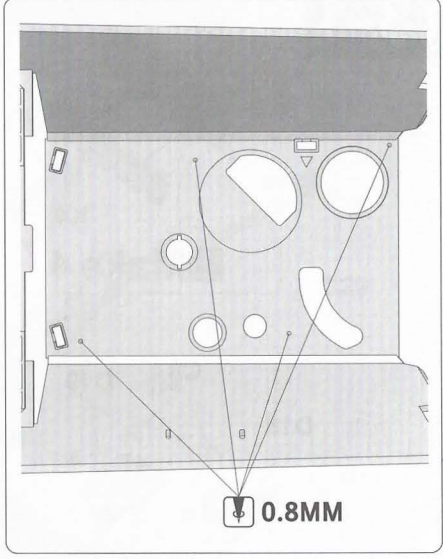
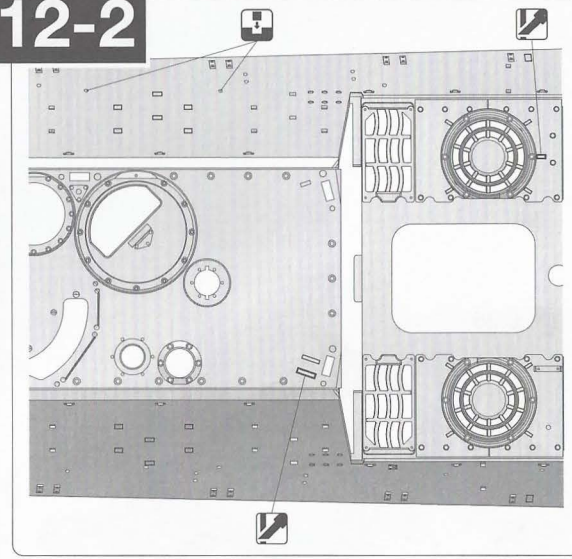

13-1

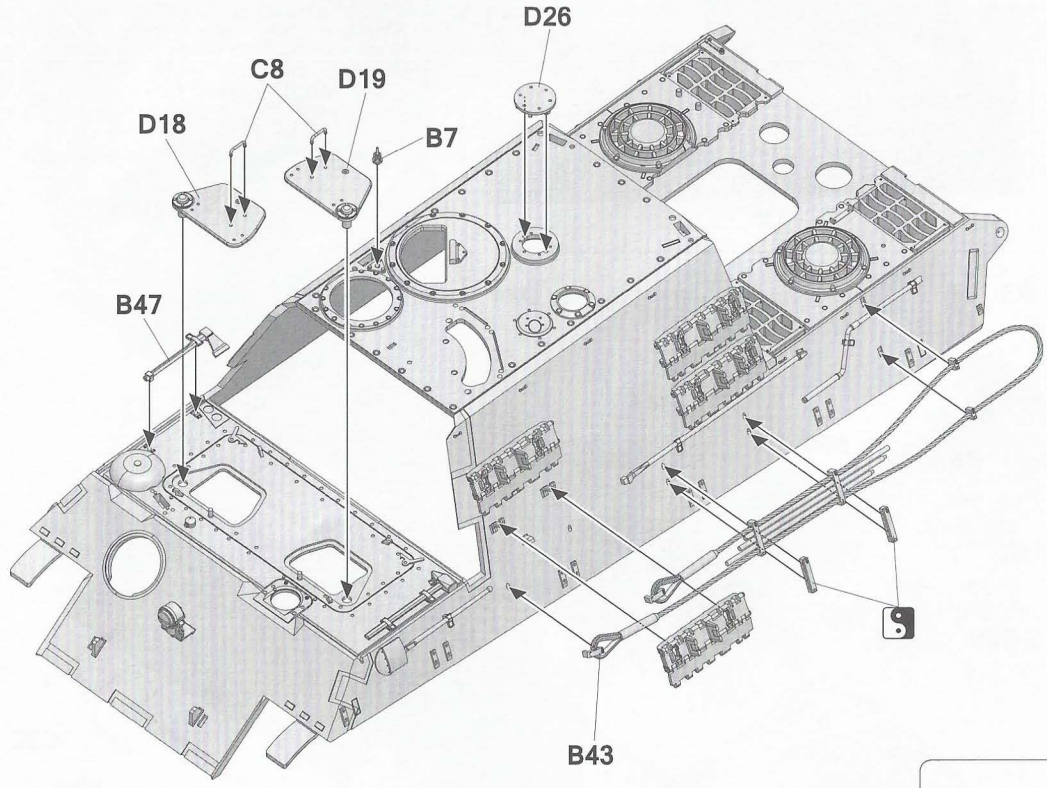
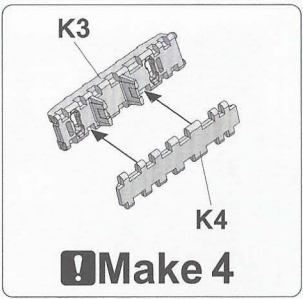

13-2

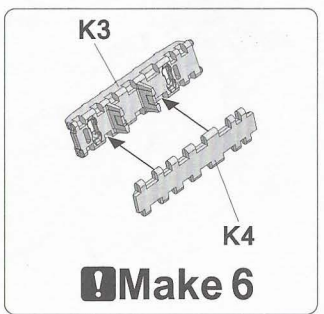
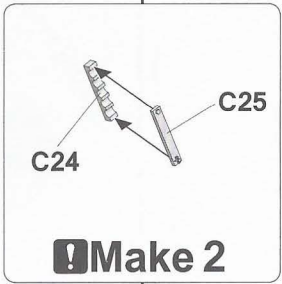
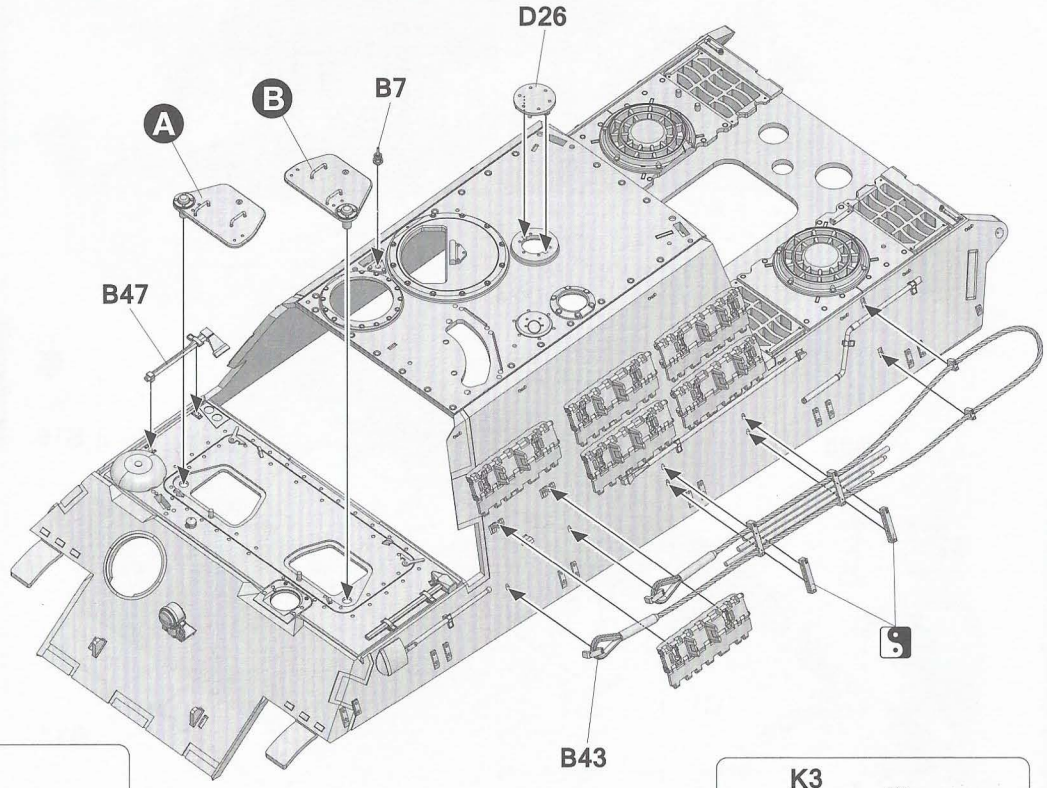
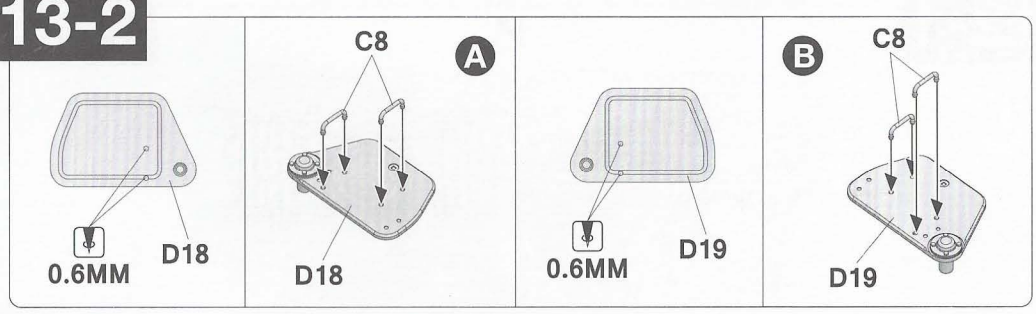

14-1

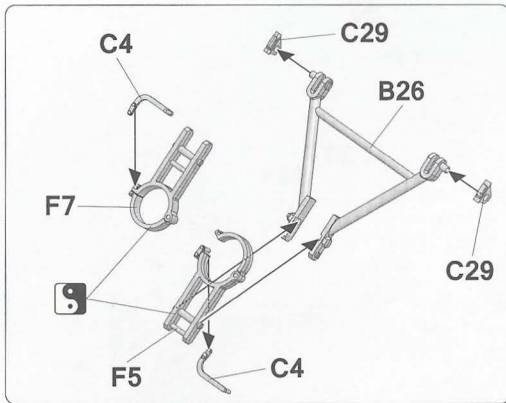

14-2

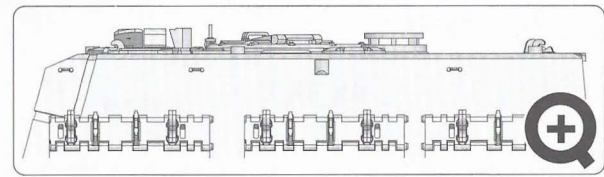
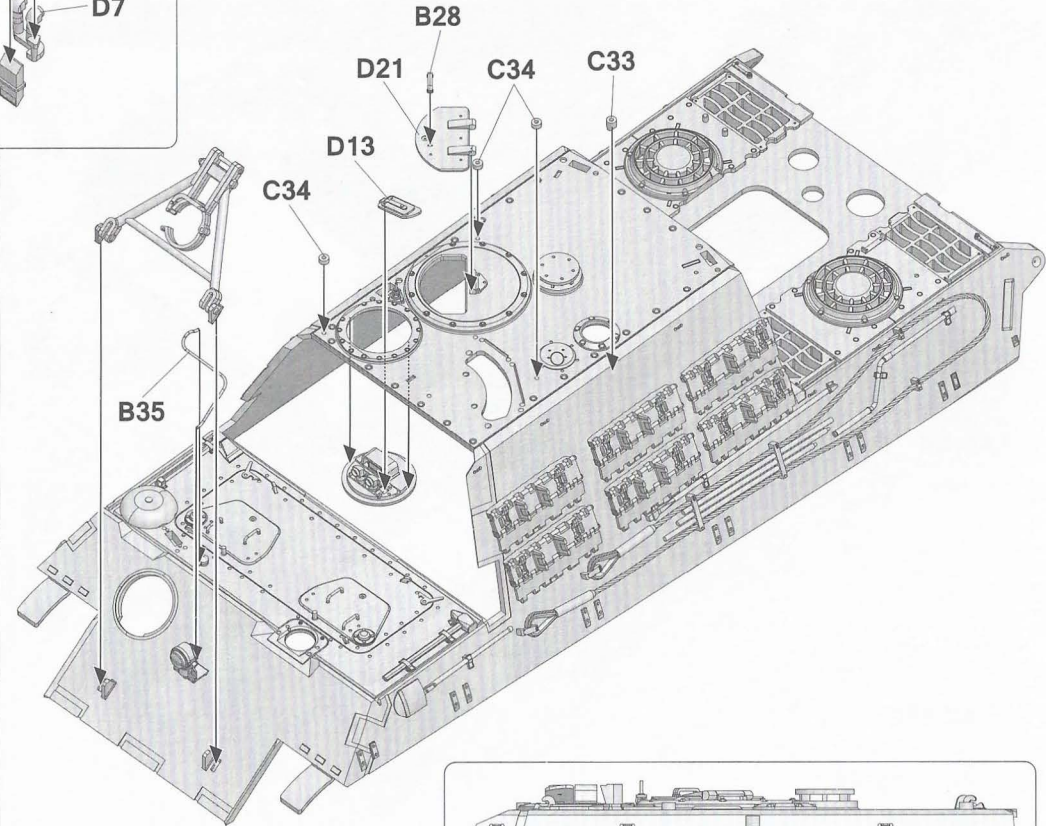
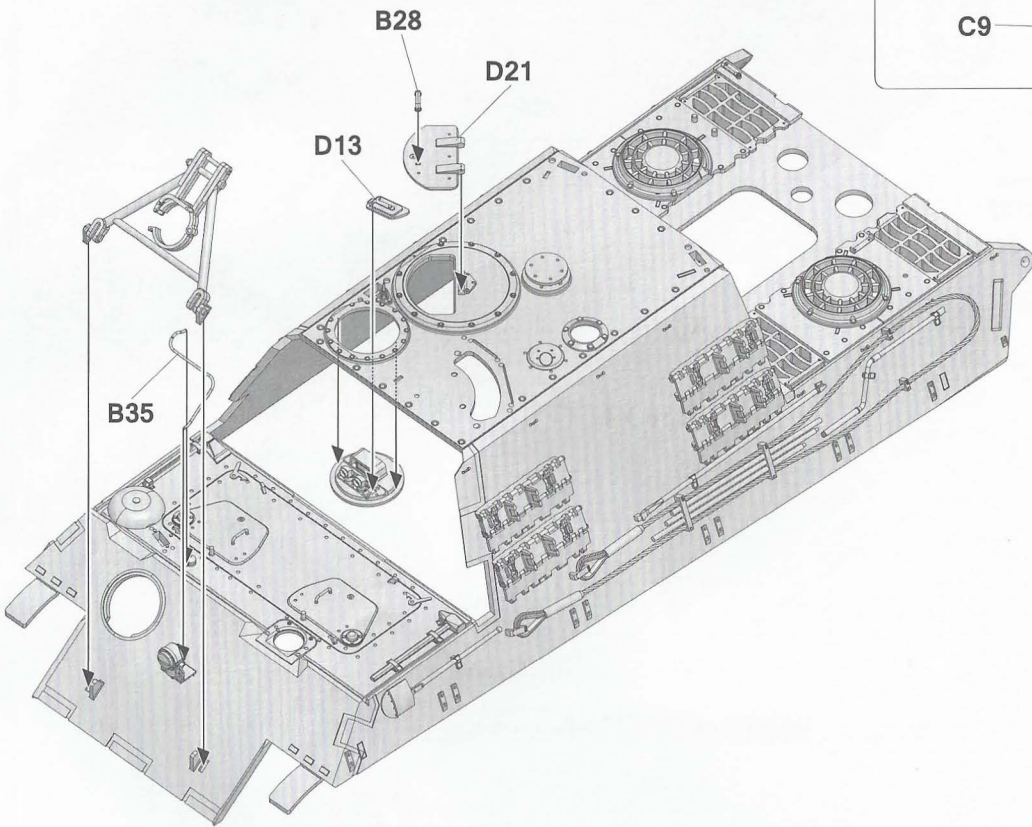
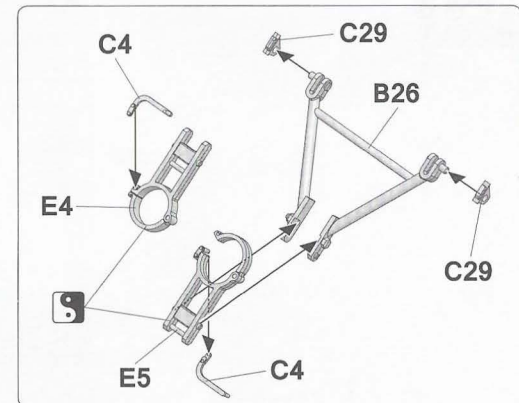
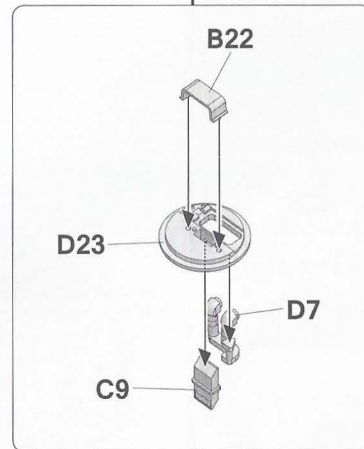

15-1

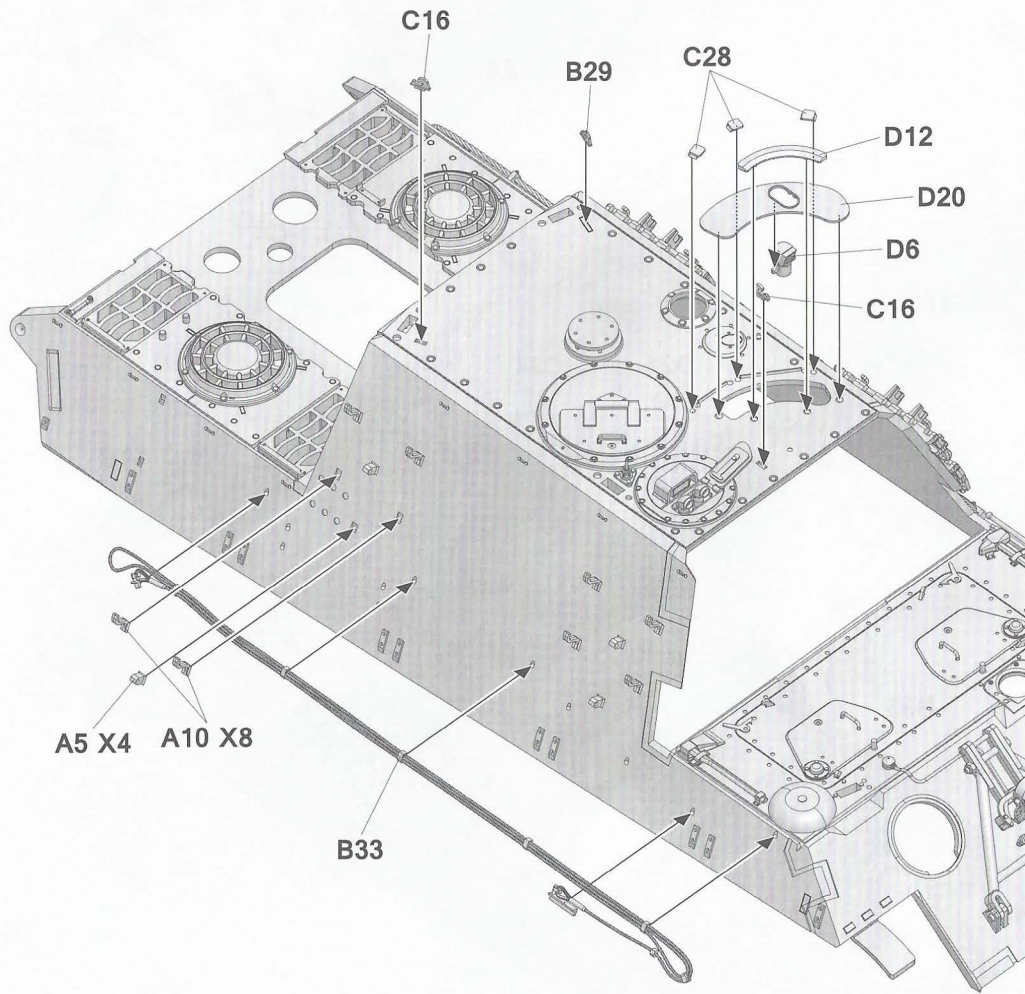

15-2

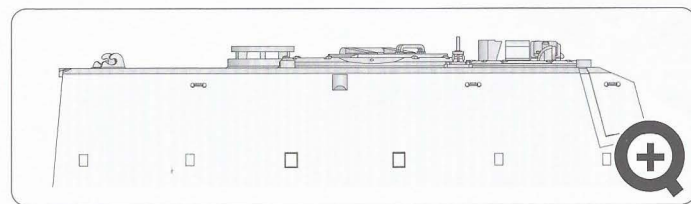
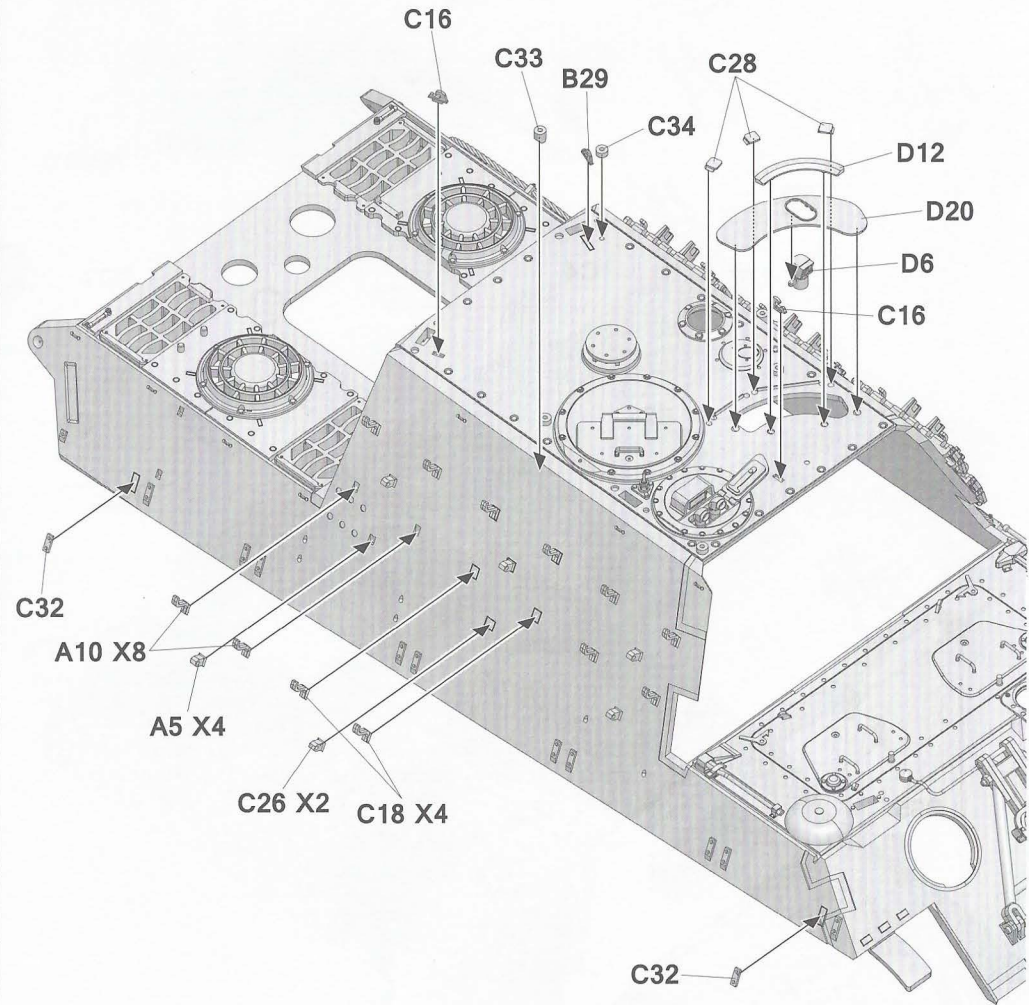

16-1

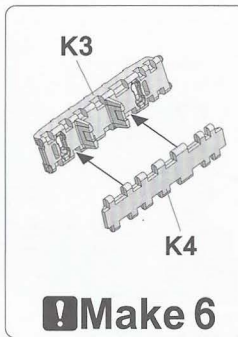
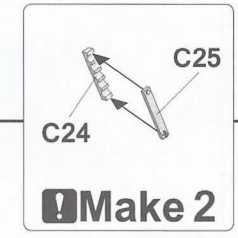
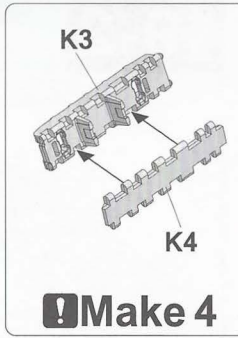
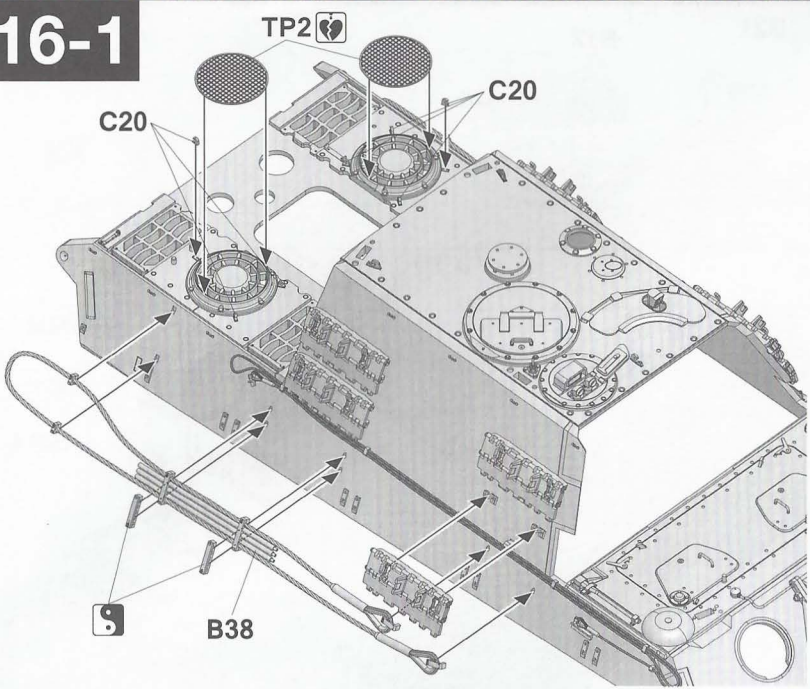

17

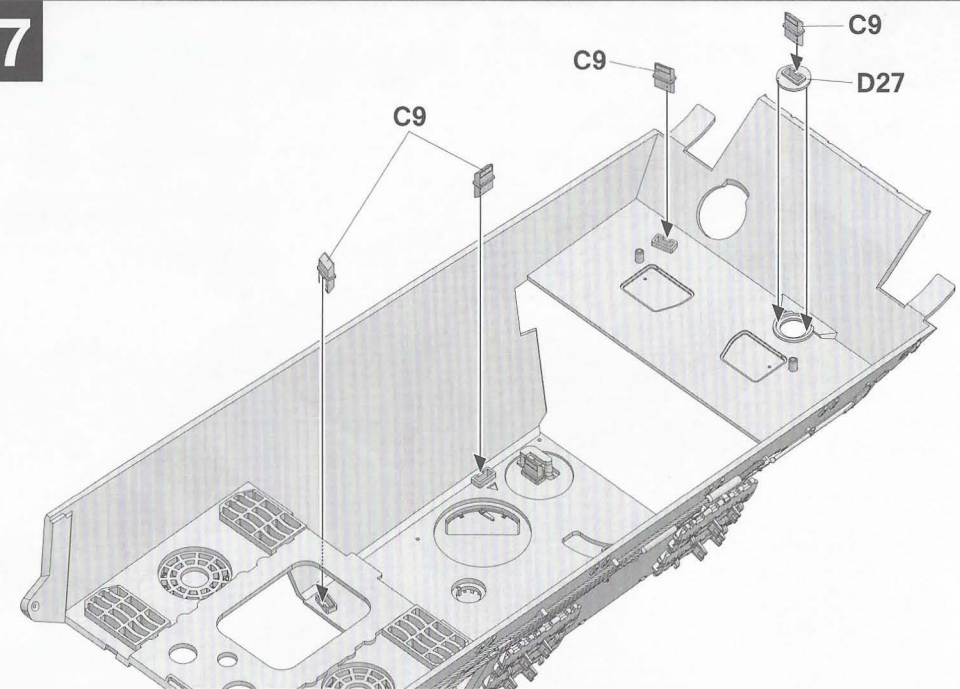

16-2

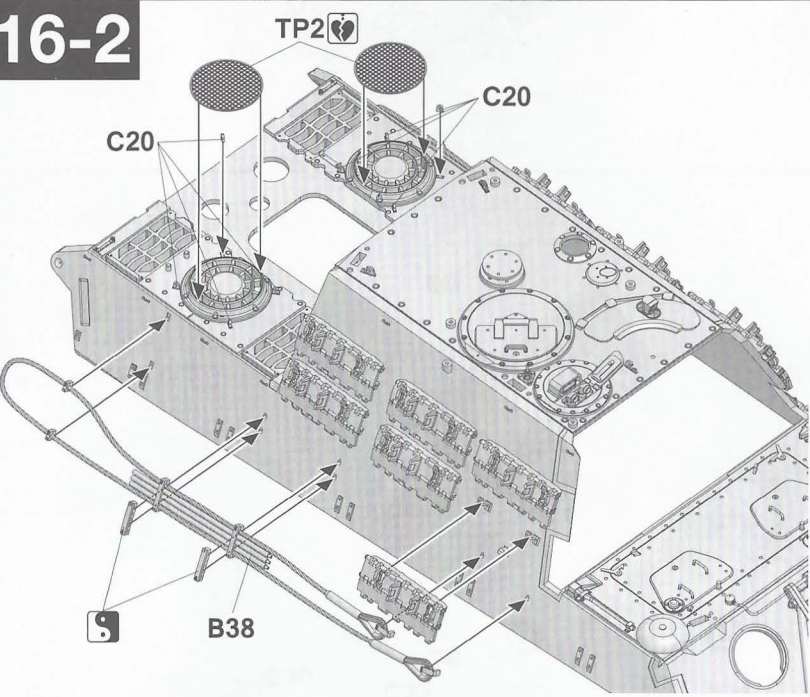

18

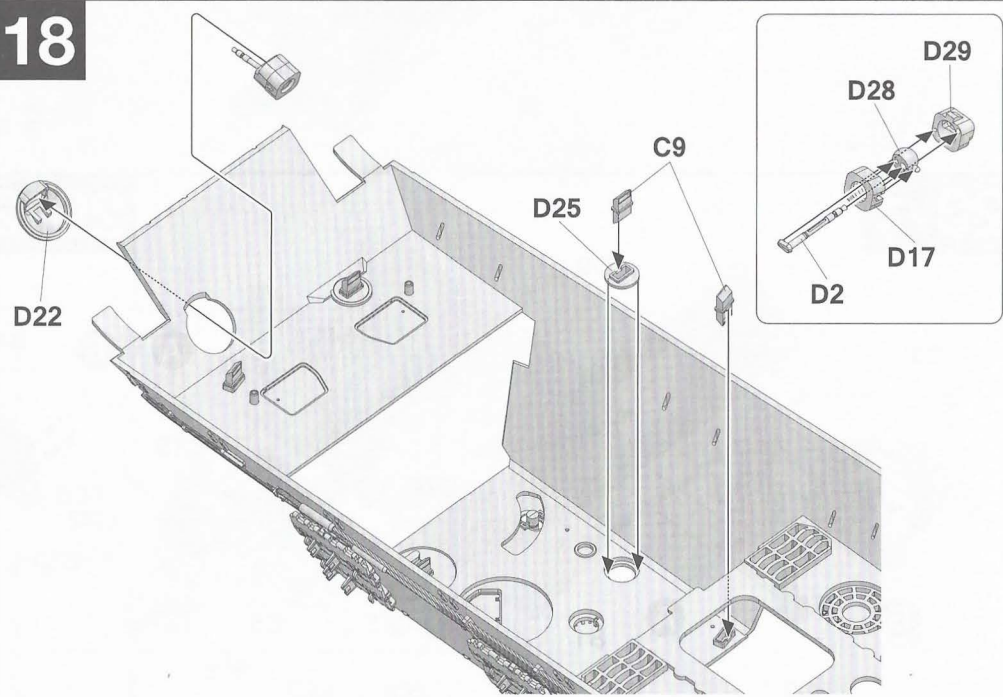

19-1

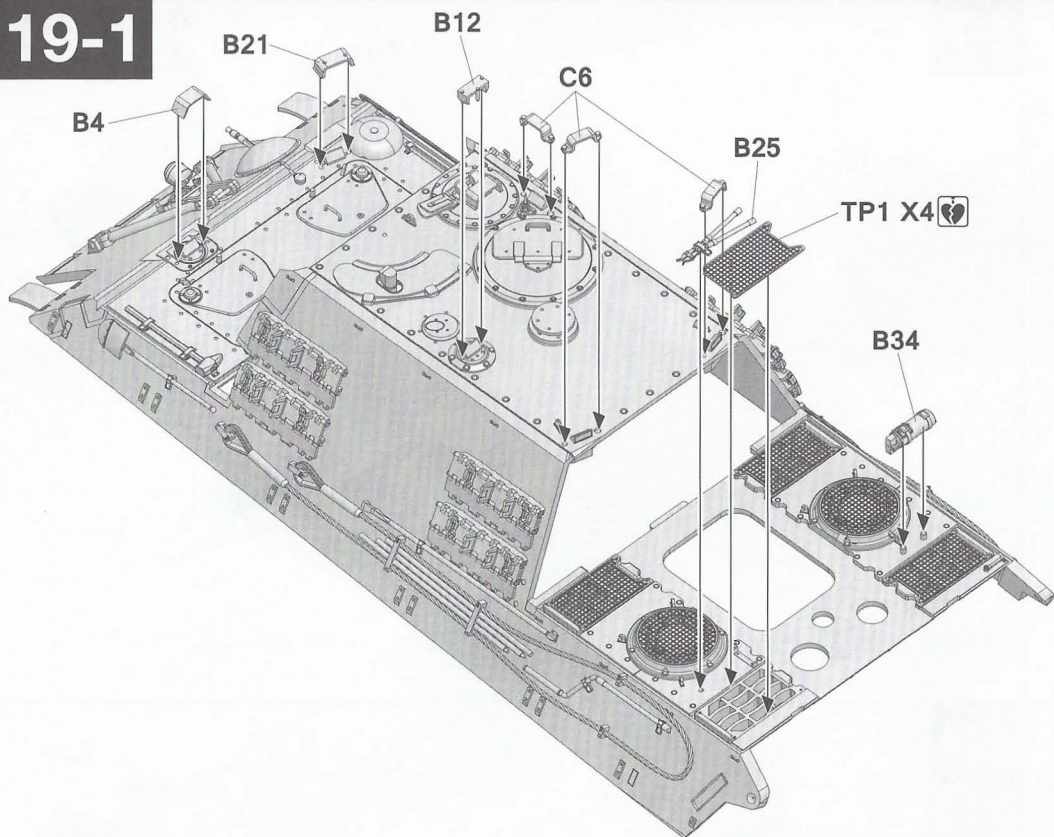

19-2

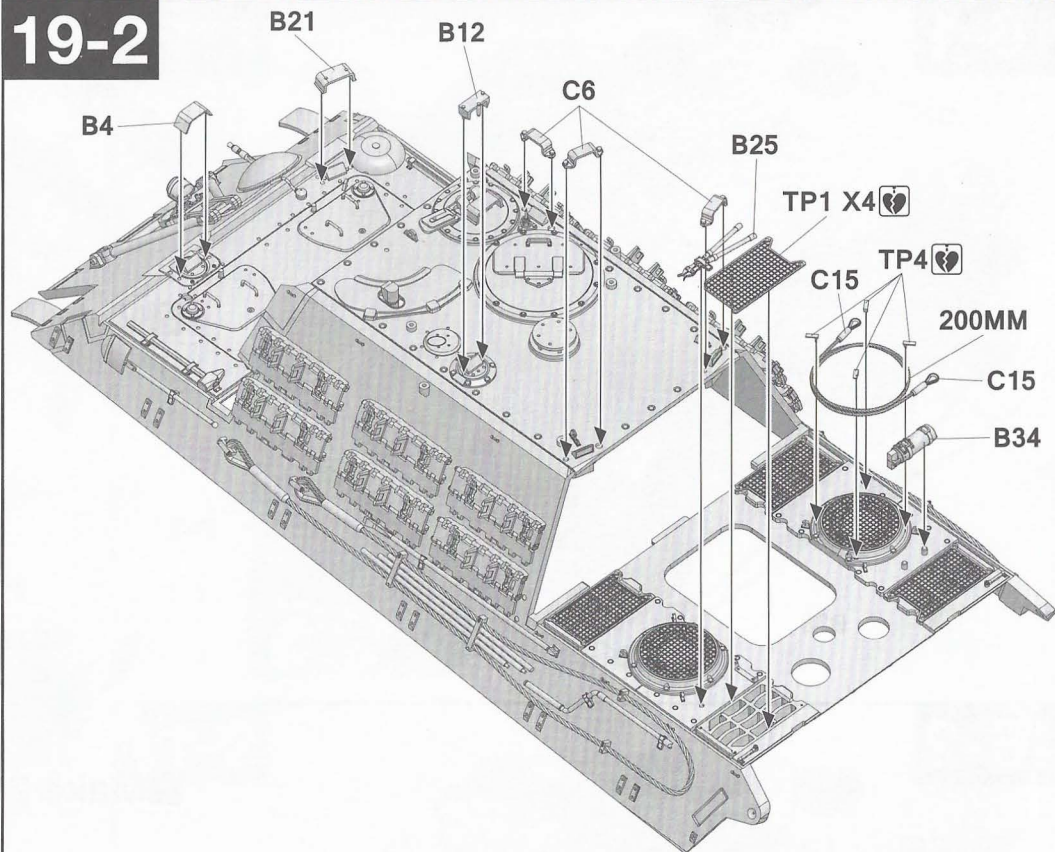

20-1

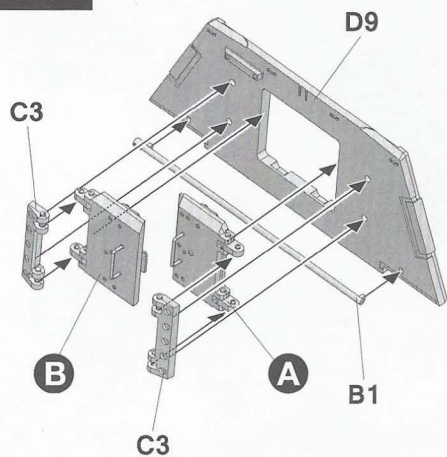

20-2

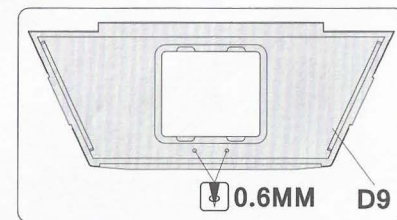
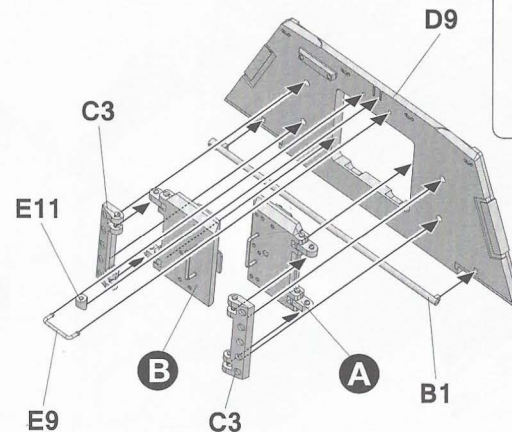
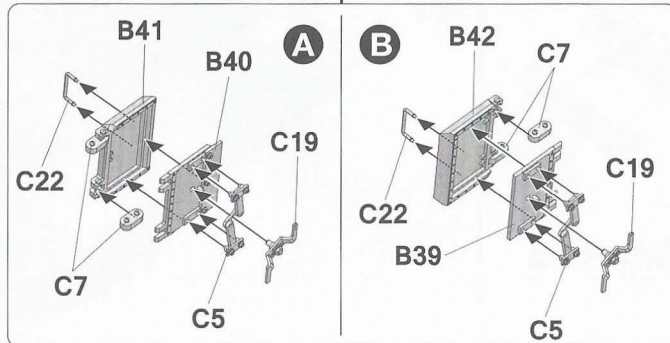

21-1

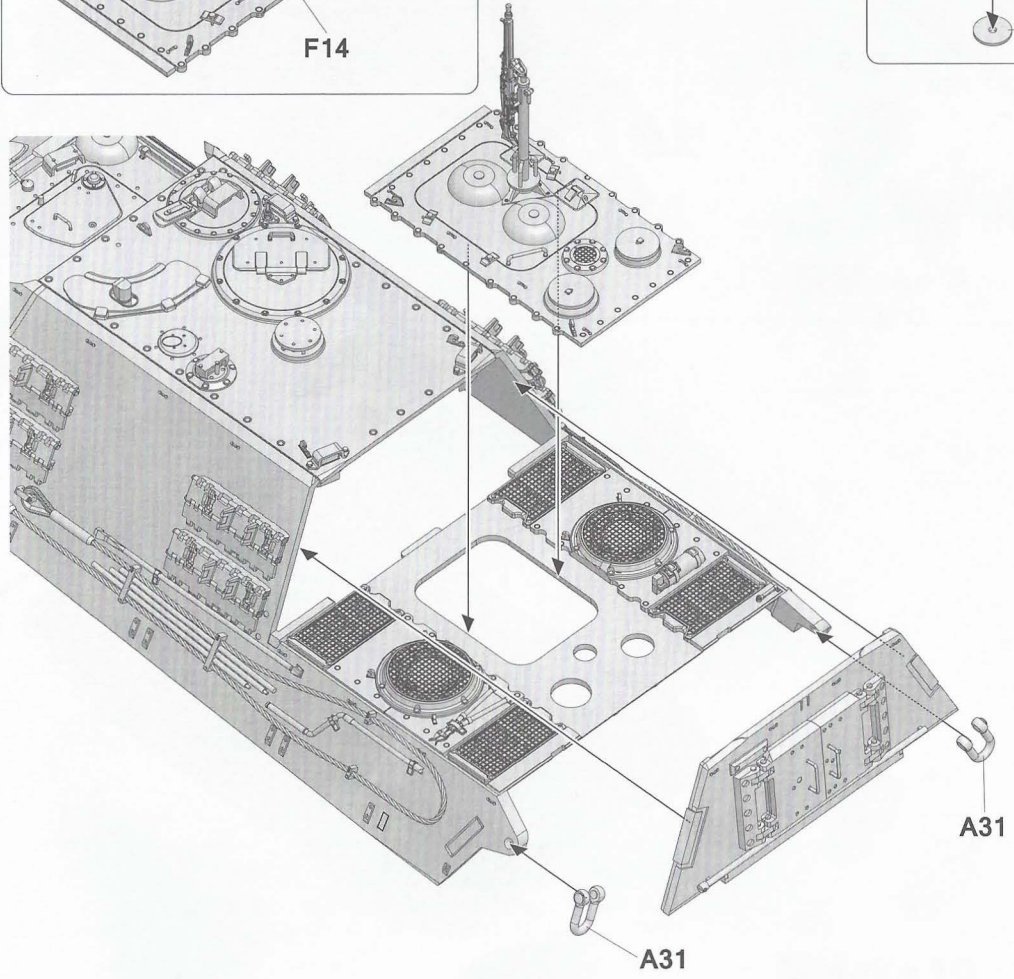
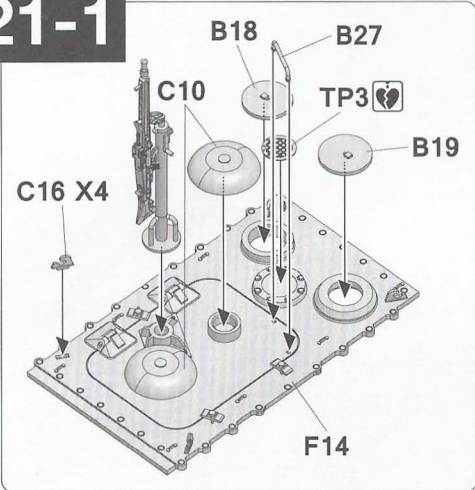

21-2

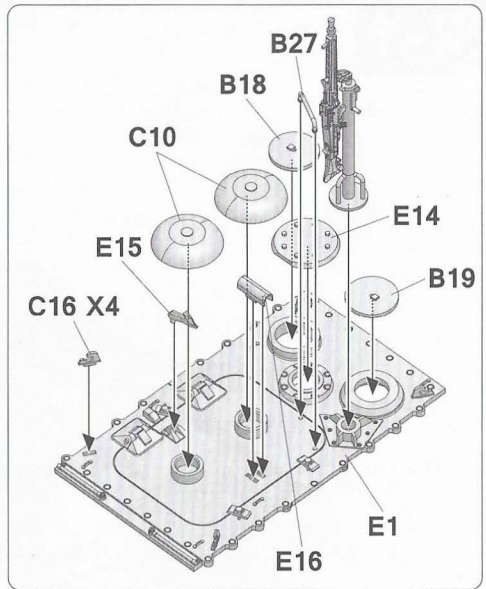
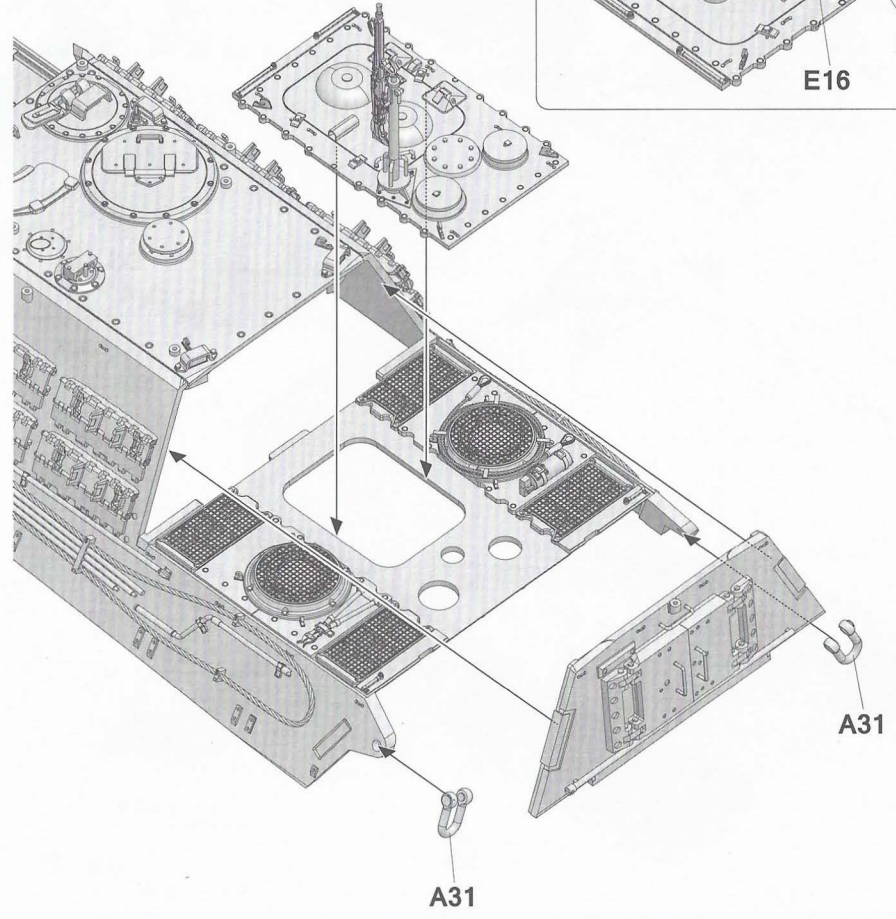
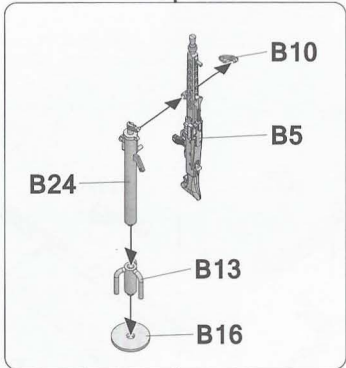

22-1

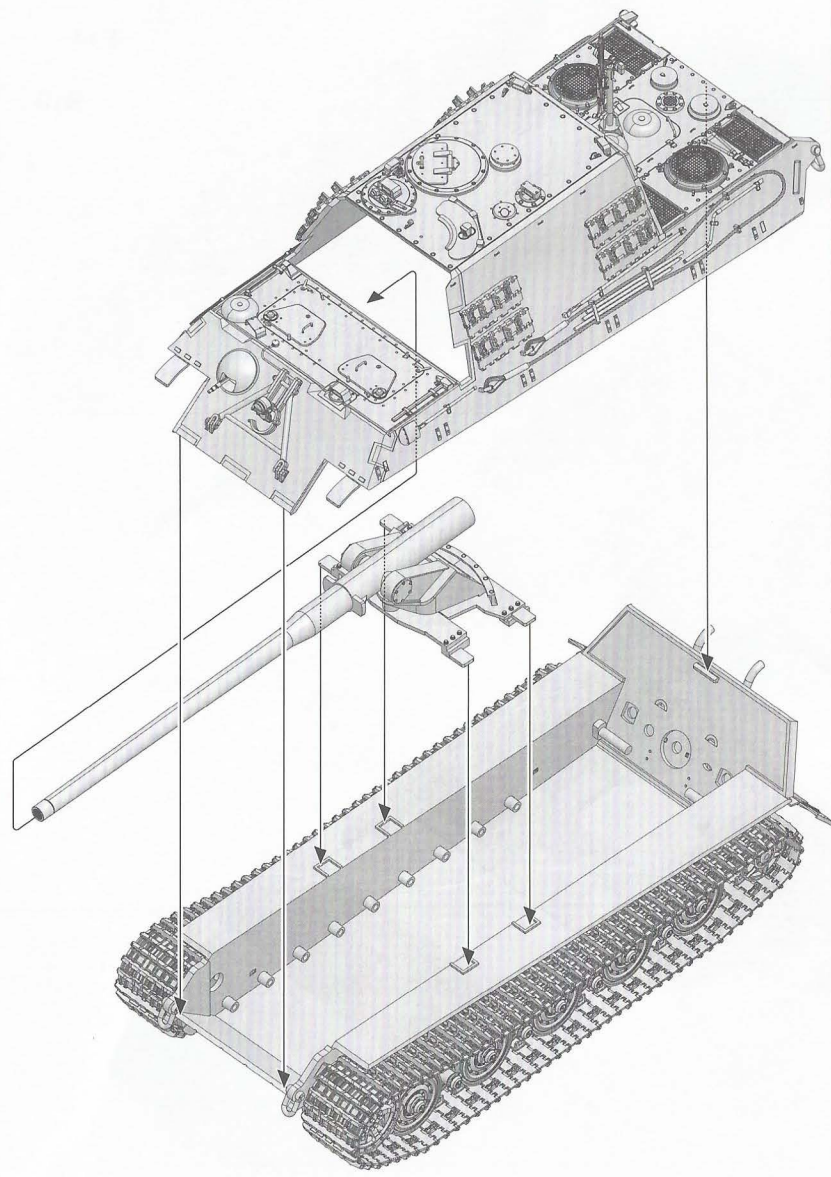

22-2

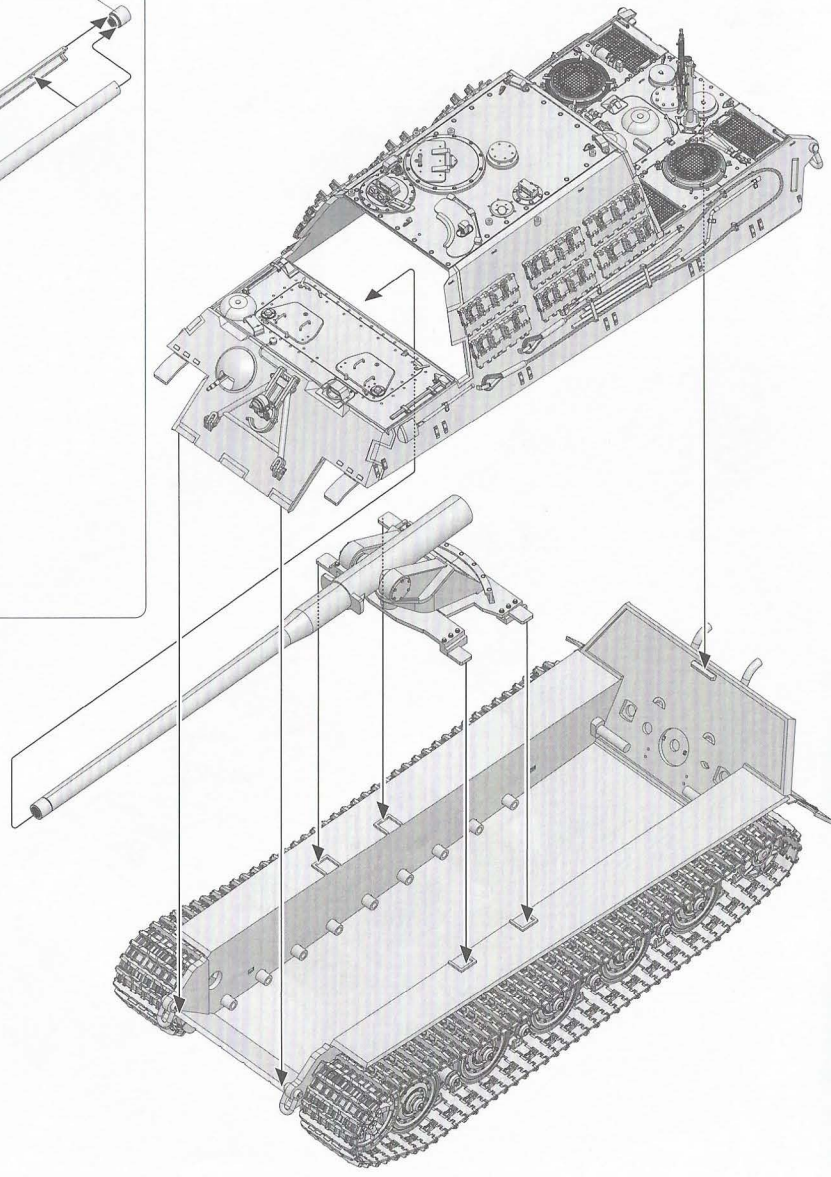
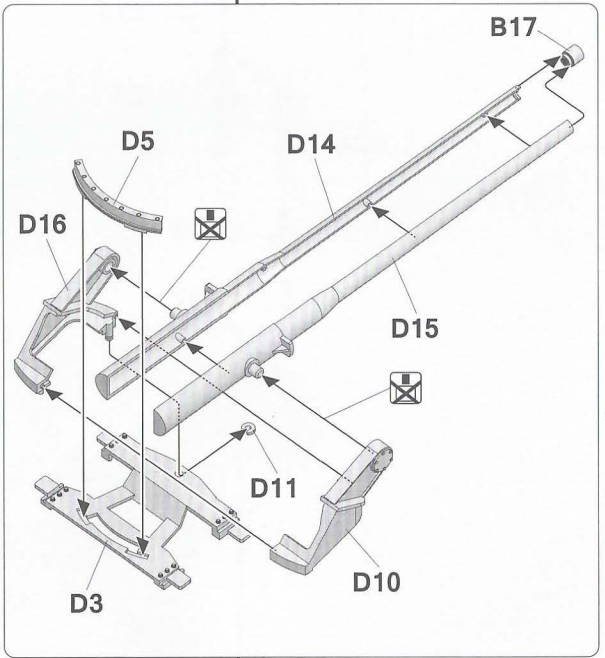

23-1

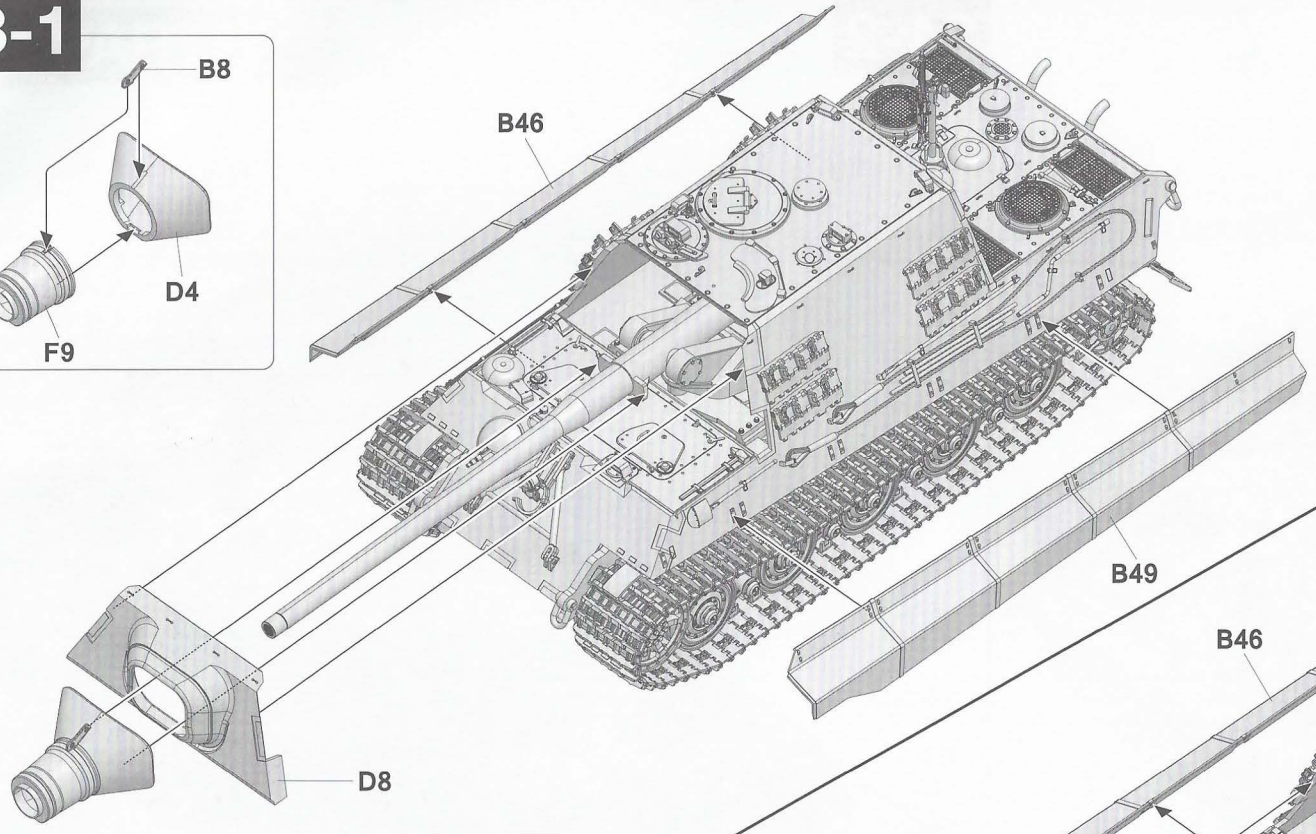
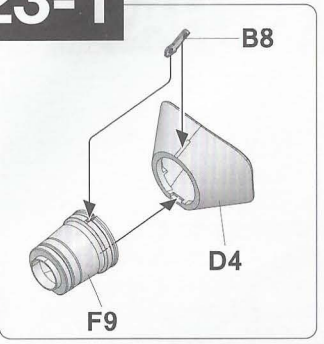

23-2

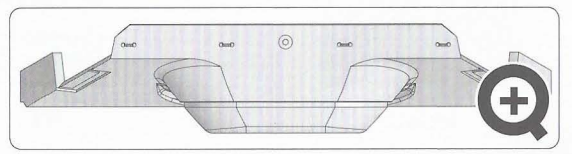
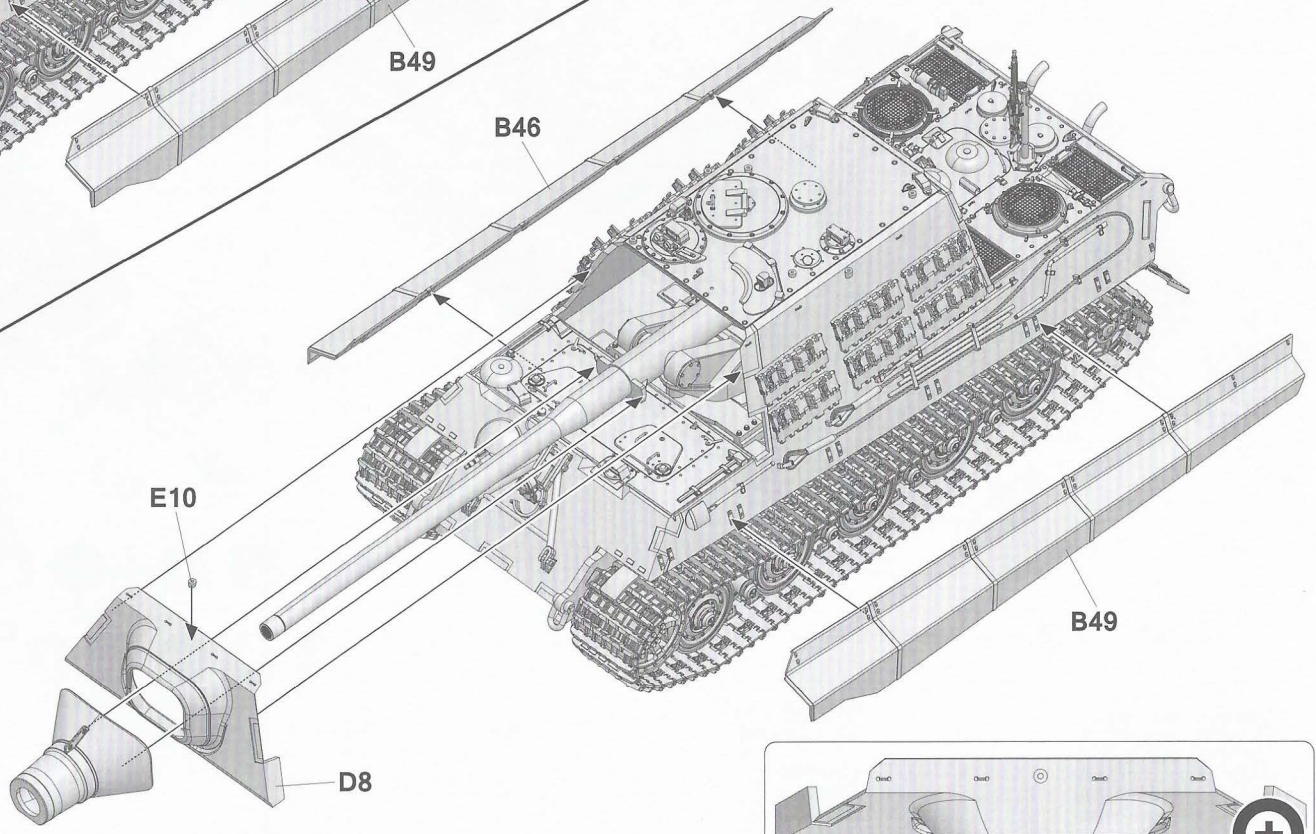
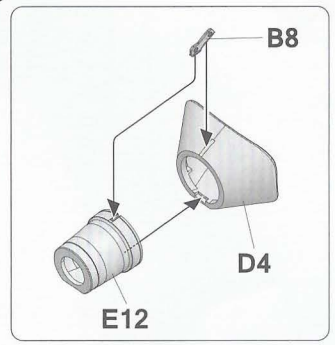

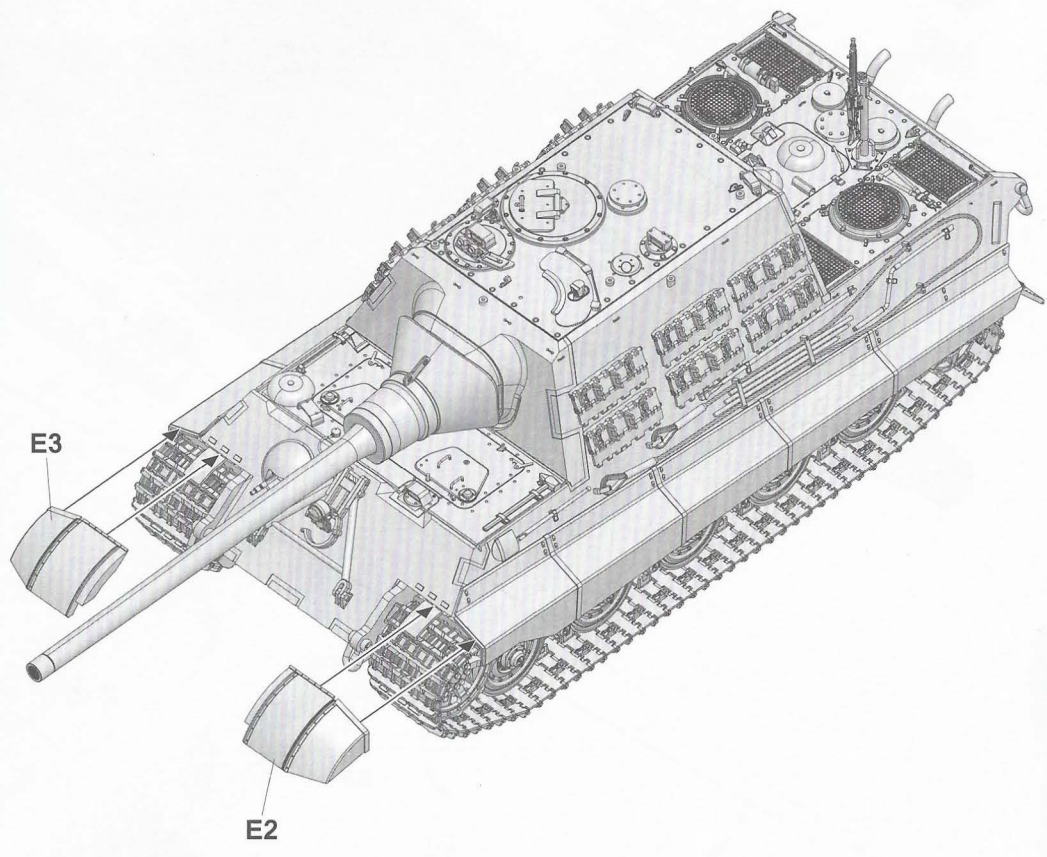
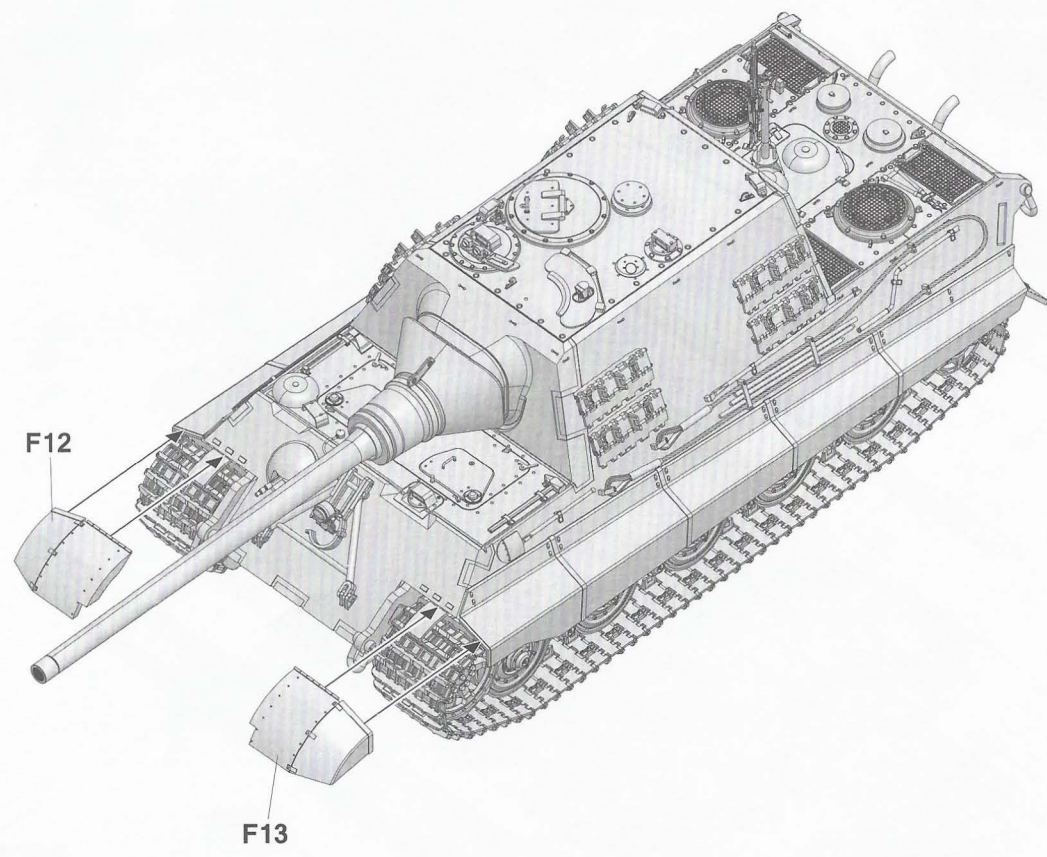

Painting and Marking Guide

TAKOM Ref: 8001

3./Schwere Panzerjäger Abteilung 653,
Neustadt am der Weinstrasse,
Germany, March 1945

- A.MIG-0032** Sain Black
- A.MIG-0034** Rust Traks
- A.MIG-0045** Gun Metal
- A.MIG-0041** Dark Rust
- A.MIG-0096** Crystal Periscope Green
- A.MIG-0037** New Wood
- A.MIG-0038** Light Wood
- A.MIG-0010** RAL 7028 Dunkelgelb (mid war)
- A.MIG-0001** RAL 6003 Olivgrün opt.1
- A.MIG-0015** RAL 8017 Schokobraun

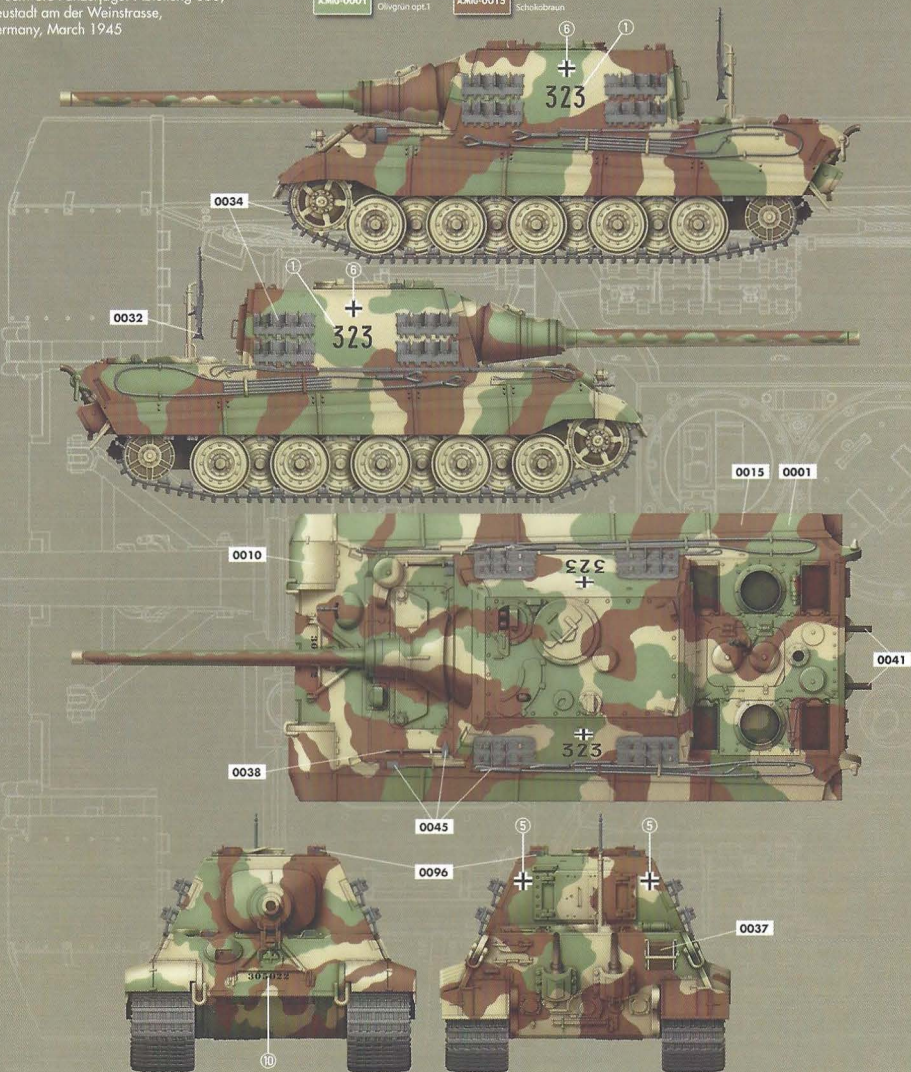

WEATHERING STEPS WITH AMMO PRODUCTS

- | | | | |
|---|---|---|---|
| 1 GENERAL WASH
A.MIG-1008 Dark Wash | 3 STREAKING
A.MIG-1206 Dark Streaking Grime | 5 RUST
A.MIG-1254 Streakingbrusher Rust | 7 MUD & SPLASHES
A.MIG-1704 Heavy Earth / A.MIG-1753 Tamed Dirt |
| 2 FILTER
A.MIG-1510 Tan for 3 Tone Camo | 4 TRACKS WASH
A.MIG-1002 Tracks Wash | 6 DUST
A.MIG-3011 Airfield Dust | 8 GREASE & OIL
A.MIG-1408 Fresh Engine Oil |

Painting and Marking Guide

TAKOM Ref: 8001

1./Schwere Panzerjäger Abteilung 653,
Schwetzingen, Germany, March 1945

- A.MIG-0032** Sain Black
- A.MIG-0034** Rust Traks
- A.MIG-0045** Gun Metal
- A.MIG-0041** Dark Rust
- A.MIG-0096** Crystal Periscope Green
- A.MIG-0037** New Wood
- A.MIG-0036** Old Wood
- A.MIG-0010** RAL 7028 Dunkelgelb (mid war)
- A.MIG-0002** RAL 6003 Olivgrün opt.2
- A.MIG-0015** RAL 8017 Schokobraun



WEATHERING STEPS WITH AMMO PRODUCTS

- | | | | |
|--|--|------------------------------------|--|
| 1 GENERAL WASH
A.MIG-1000 Brown Wash for Dark Yellow | 3 STREAKING
A.MIG-1203 Streaking Grime | 5 RUST
A.MIG-3510 Rust | 7 MUD & SPLASHES
A.MIG-1703 Moist Ground / A.MIG-1752 Loose Ground |
| 2 FILTER
A.MIG-1510 Tan for 3 Tone Camo | 4 TRACKS WASH
A.MIG-1002 Tracks Wash | 6 DUST
A.MIG-3013 Rubble | 8 GREASE & OIL
A.MIG-1408 Fresh Engine Oil |

Painting and Marking Guide

TAKOM Ref: 8001

3./Schwere Panzerjäger Abteilung 653,
Morsbronn, Germany, March 1945

A.MIG-0032	Satin Black	A.MIG-0034	Rust Traks	A.MIG-0045	Gun Metal	A.MIG-0041	Dark Rust
A.MIG-0096	Crystal Periscope Green	A.MIG-0037	New Wood	A.MIG-0038	Light Wood	A.MIG-0010	RAL 7028 Dunkelgelb (mid-wat)
A.MIG-0001	RAL 6003 Olivgrün opt.1	A.MIG-0015	RAL 8017 Schokobraun				



WEATHERING STEPS WITH AMMO PRODUCTS

1 GENERAL WASH A.MIG-1000 Brown Wash for Dark Yellow	3 STREAKING A.MIG-1256 Streakingbrusher Green-Grey Grime	5 RUST A.MIG-1204 Streaking Rust	7 MUD & SPLASHES A.MIG-1705 Wet Mud / A.MIG-1754 Damp Earth
2 FILTER A.MIG-1510 Tan for 3-Tone Camo	4 TRACKS WASH A.MIG-1002 Tracks Wash	6 DUST A.MIG-3004 Europe Earth	8 GREASE & OIL A.MIG-1408 Fresh Engine Oil

Painting and Marking Guide

TAKOM Ref: 8001

2./Schwere Panzerjäger Abteilung 512,
Bad Driburg, Germany, April 1945

A.MIG-0032	Satin Black	A.MIG-0034	Rust Traks	A.MIG-0045	Gun Metal	A.MIG-0041	Dark Rust
A.MIG-0096	Crystal Periscope Green	A.MIG-0014	RAL 8012 Rotbraun	A.MIG-0036	Old Wood	A.MIG-0012	RAL 7028 Dunkelgelb aus '44 DG III
A.MIG-0003	RAL 6011 Reiseidgrün						

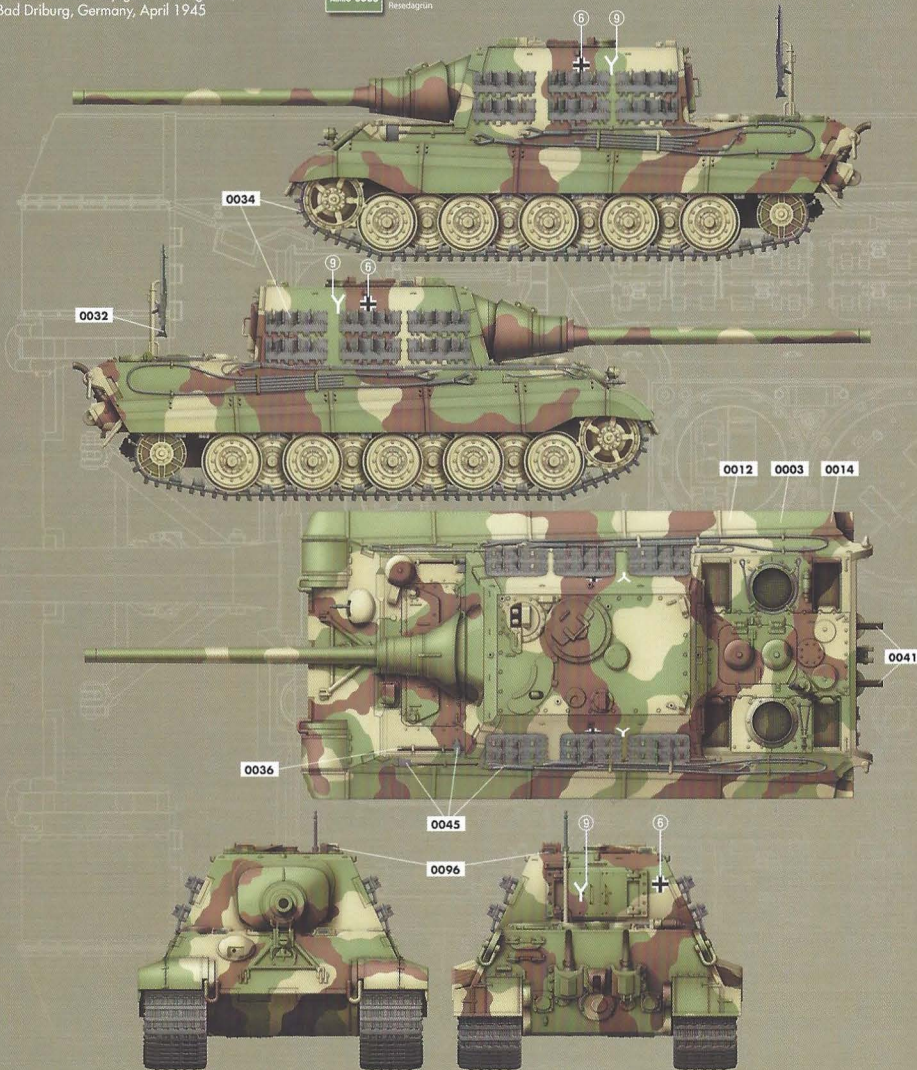

WEATHERING STEPS WITH AMMO PRODUCTS

1 GENERAL WASH A.MIG-1005 Dark Brown Wash for Green vehicles	3 STREAKING A.MIG-1253 Streakingbrusher Grime	5 RUST A.MIG-3510 Rust	7 MUD & SPLASHES A.MIG-1704 Heavy Earth / A.MIG-1753 Turned Dirt
2 FILTER A.MIG-1510 Tan for 3-Tone Camo	4 TRACKS WASH A.MIG-1002 Tracks Wash	6 DUST A.MIG-3028 City Dark Dust	8 GREASE & OIL A.MIG-1408 Fresh Engine Oil

Painting and Marking Guide

TAKOM Ref: 8001

3./Schwere Panzerjäger Abteilung 653,
Neustadt am der Weinstrasse,
Germany, March 1945

- | | | | |
|--|--|------------------------------|--|
| A.MIG-0032 Satin Black | A.MIG-0034 Rust Traks | A.MIG-0045 Gun Metal | A.MIG-0041 Dark Rust |
| A.MIG-0096 Crystal Parrot Green | A.MIG-0037 New Wood | A.MIG-0038 Light Wood | RAL 7028 Dunkelgrün Aus 44 DG I |
| A.MIG-0004 RAL 6011 B Renselagrün | A.MIG-0015 RAL 8017 Schokobraun | | |



WEATHERING STEPS WITH AMMO PRODUCTS

- | | | | |
|--|--|---|--|
| 1 GENERAL WASH
A.MIG-1005 Dark Brown Wash for Green vehicles | 3 STREAKING
A.MIG-1253 Streaking/brusher Grime | 5 RUST
A.MIG-1204 Streaking Rust | 7 MUD & SPLASHES
A.MIG-1703 Moist Ground / A.MIG-1752 Loose Ground |
| 2 FILTER
A.MIG-1510 Tan for 3 Tone Camo | 4 TRACKS WASH
A.MIG-1002 Tracks Wash | 6 DUST
A.MIG-3030 Factory Dirt Ground | 8 GREASE & OIL
A.MIG-1408 Fresh Engine Oil |

GERMAN TANK DESTROYER Sd.Kfz.173 JAGDPANTHER G1 Early Production w/Zimmerit



1/35
No 2125

- A. THIS IS NOT A TOY
- A. READY TO ASSEMBLE PRECISION MODEL KIT
- A. INTENDED FOR COLLECTORS OF AGE 14 YEARS AND ABOVE
- A. MODEL MAY VARY FROM IMAGE ON BOX
- A. CEMENT AND PAINT NOT INCLUDED

Designed by
Trekstudio
in China
Zimmerit Pattern
created by
JASON

DETAILED STATIC DISPLAY PLASTIC MODEL
TRACK ASSEMBLY IS AIDED WITH THE USE OF A JOE
LINK & LENGTH STYLE TRACKS INCLUDED
ALL HATCHES CAN BE BUILT IN OPEN OR CLOSED POSITION
PE INCLUDED
4 TYPES OF MARKINGS
FIGURE NOT INCLUDED

Full Interior

U.S. ARMY 1/4 TON UTILITY TRUCK WITH 1/4 TON UTILITY TRAILER & MP FIGURE



A. THIS IS NOT A TOY - A. READY TO ASSEMBLE PRECISION MODEL KIT
A. MODEL MAY VARY FROM IMAGE ON BOX - A. CEMENT AND PAINT NOT INCLUDED - A. INTENDED FOR COLLECTORS OF AGE 14 YEARS AND ABOVE

JASON 2009

Figure sculpted by
JASON

1/35
No 2299

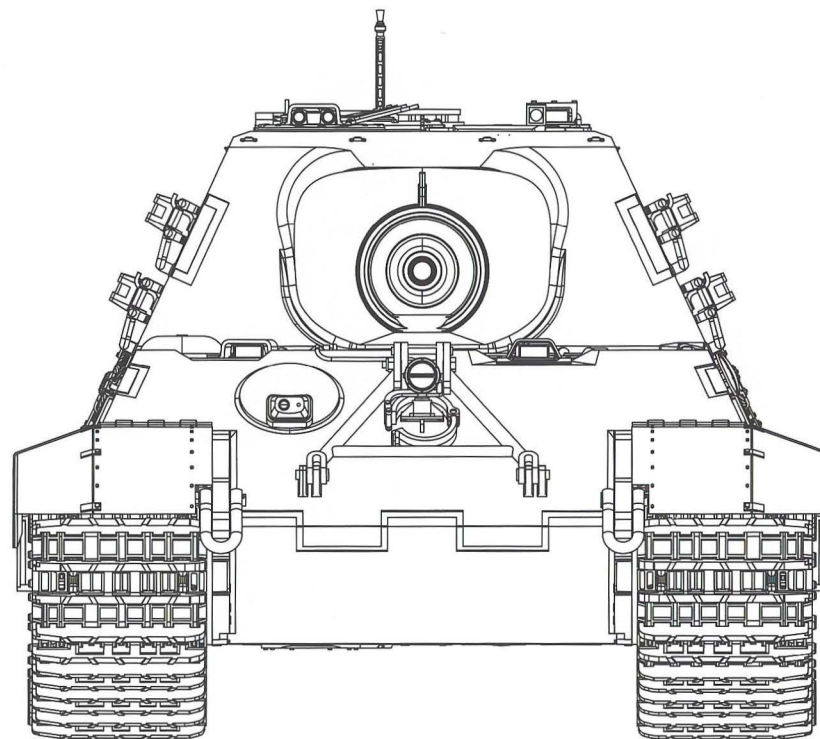

You can find TAKOM on Facebook.com

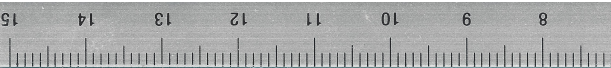

① 323 323 ② 332 332
③ 131 131 ④ 331 331
⑤ + + + + ⑥ + + + ⑦ +
⑧ + + + + ⑨ Y Y Y +
⑩ 305022 ⑪ 305020

© 2019 **BLITZ**
03.04.8001

