

1 Assigned to German Airforce (African Division)

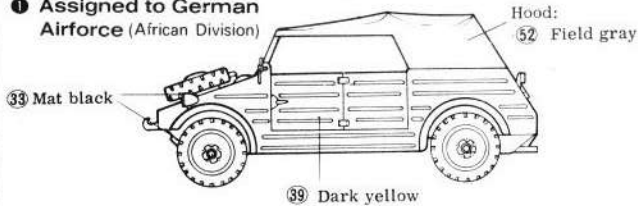

2 German Bodyguard Unit (Schutz-staffeln)

Theodor Eicke Lt. General Official Car (1941 - 1942)

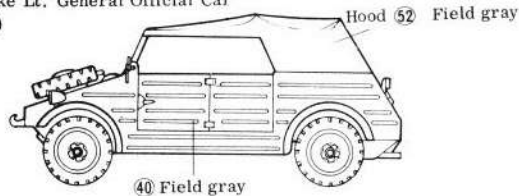

3 Assigned to German Airforce (African Division)

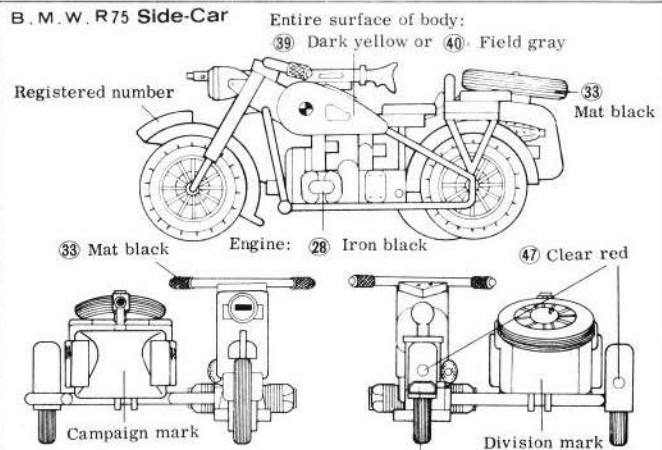
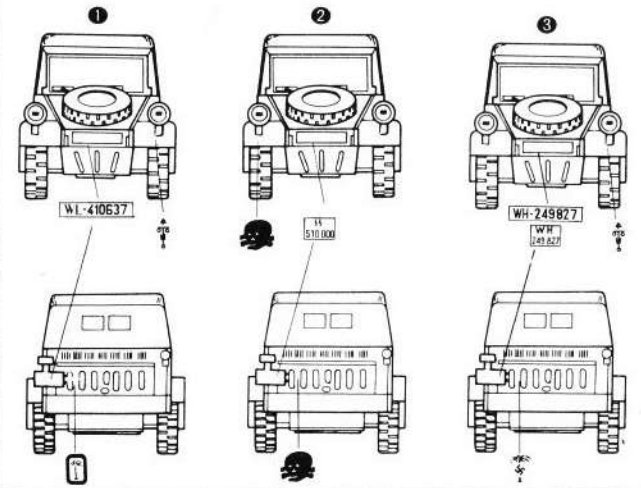

Registered Number	Division Mark	Campaign Mark	Registered number (same as on front fender)
1 44-156448	+		German Bodyguard Unit (Schutz-staffeln): (40) Field gray
2 WL-99530	+	+	German Airforce: (39) Dark yellow
3 WW-99720	+	+	German National Defense Force (African Division) (46th Infantry Division): (39) Dark yellow

Painting

After February 1943, the colors on all of the German military vehicles were changed to dark yellow. For the camouflage purpose, olive drab and red brown were added according to the geographic condition of the warfront. These colors were either sprayed, brushed or splashed on. There were many types of camouflage---inkspot, stripes, zig-zag. In the winter, winter white (grayish white) was brushed on, but as it was water paint, it worn off and became the camouflage of white and the base color. In the spring of 1945, German gray was used on only the heavy tanks and artilleries. To draw out the real feeling, the model should have a dirty appearance; the gloss must be removed and chassis be painted in sandy or brown.

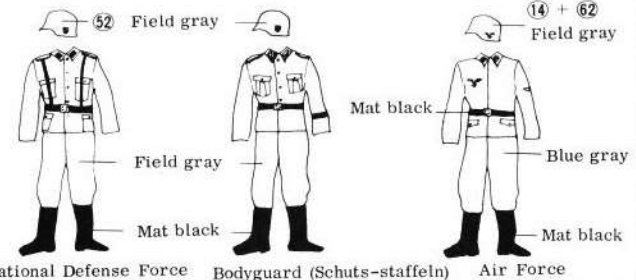

National Defense Force Bodyguard (Schutz-staffeln) Air Force

Parts Drawing (Before removing the parts from the stem, be sure to check them with the drawing.)

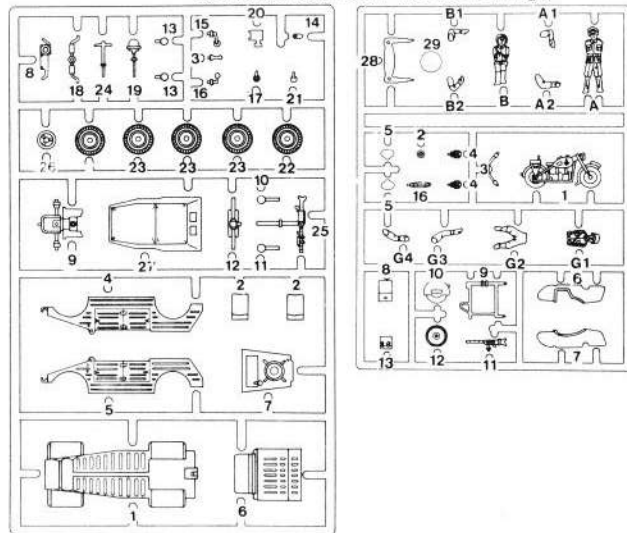

Parts No. & Description

KÜBELWAGEN	
1. Frame	27. Hood (A)
2. Seat	28. Hood (B)
3. Gear shift lever	A, A1 and A2: Officers
4. Side panel (right)	B, B1 and B2: Drivers
5. Side panel (left)	
6. Engine cover	
7. Bonnet	
8. Instrument panel	
9. Rear differential	
10. Exhaust pipe	BMW R75 SIDE-CAR
11. Exhaust pipe	1. Motorcycle chassis
12. Front axle	2. Headlight
13. Headlight	3. Handle
14. Blackout light	4. Engine
15. Back mirror	5. Seat
16. Spot light	6. Side-car (right)
17. Horn	7. Side-car (left)
18. Machine gun mount	8. Seat
19. Shovel	9. Frame
20. Number plate	10. Side-car tire
21. Taillight	11. Machine gun
22. Spare tire	12. Spare tire
23. Tire	13. Saddle bag
24. Pick	16. Muffler
25. Machine gun	Transparent part: 1 pc.
26. Steering wheel	

★ After the parts are taken, cut the bag in pieces to prevent the infant from covering it's head.

Decal

- Place in water and remove it immediately.
- With the decal facing up, slide it off.
- After placing the decal on the model, use soft cloth to remove the bubbles.
- Do not touch the decal until it is well dried.

KÜBELWAGEN & B.M.W. SIDE-CAR

1/72 SCALE



Kit No.MB-012

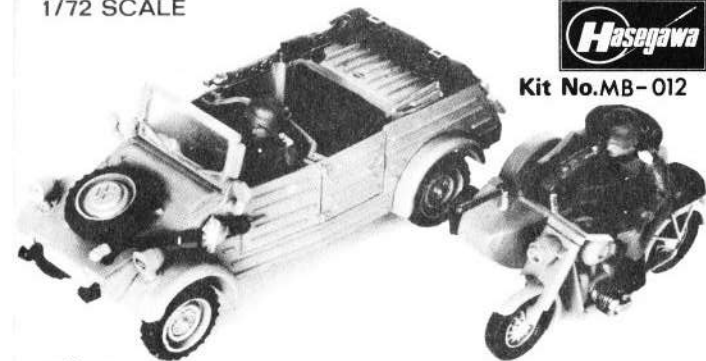

Kübelwagen

Like the U. S. Willys Jeep, Kübelwagen was one of the famous light vehicles during the World War II. It was designed by Ferdinand Porsche in 1938, using the basic chassis of the Volkswagen. For mass production, this was entirely of simple structure. Several thousands were produced during the war, seeing service in all areas as reconnaissance and liason capacity, and played a great part of the success in the warfare.

Length: 3.73 m / Width: 1.60 m / Height: 1.65 m / Engine: Air-cooled horizontal counter 4 cylinder, 1,131 cc / Max. speed: 85 km/h / Range: Approximate 400 km

B.M.W. R75 Side-Car

From just the beginning of World War II, the motorcycle outfit in the German army played the leading role in its mechanized unit. By making use of its mobility, Zündapp, NSU, DKW and other types of motorcycle served for the German military force. On the motorcycle over 500 cc the side-car was installed. The BMW R 75, for its reliability in engineering and sturdy chassis, served throughout the war as a reconnaissance and liason capacity.

Length: 2.40 m / Height: 1.00 m / Width: 1.73 m / Weight: 400 kg. (with side-car) / Engine: BMW horizontal counter 2 sylinder, 746 cc / Max. speed: 95 km (with side-car)

MANUFACTURED IN JAPAN & PACKED IN ENGLAND
By A. A. HALES LTD.
HINKLEY, LEICS.



Before Assembling Your Kit

- Read these instructions carefully before assembling your model and check the exact fit of the parts.
- Clean off excess plastic, if any, with a sharp knife or a file.
- Do not tear off parts from the stem, but cut them off carefully with a knife or clipper.
- Do not use too much cement since surplus adhesive spoil the finish.

MODEL COLORS

To beautify your model, paint each parts carefully. The model colors are from ① - 60. Use wide brush to paint the wide area and the pointed brush for tiny parts.



Kubelwagen Assembly

① Body Assembly (1)

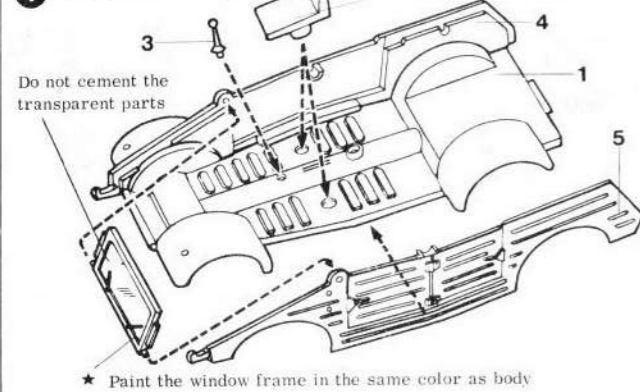

② Body Assembly (2)

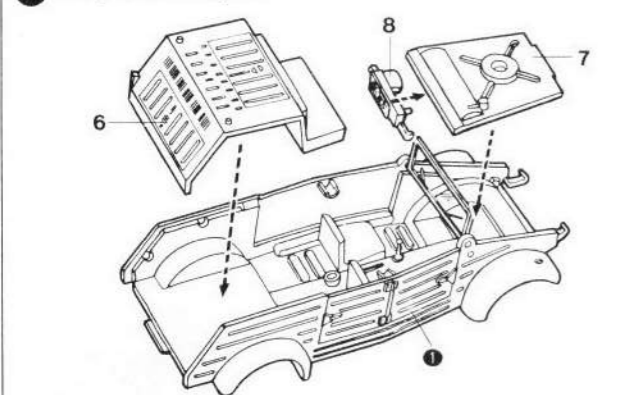

③ Body Bottom Assembly

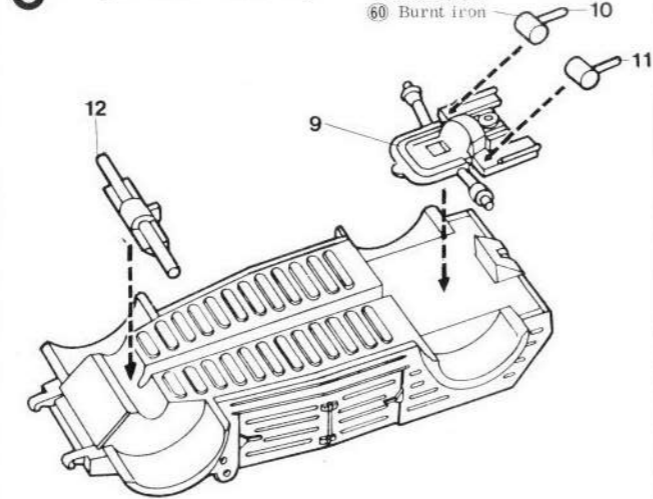

④ Parts Cement

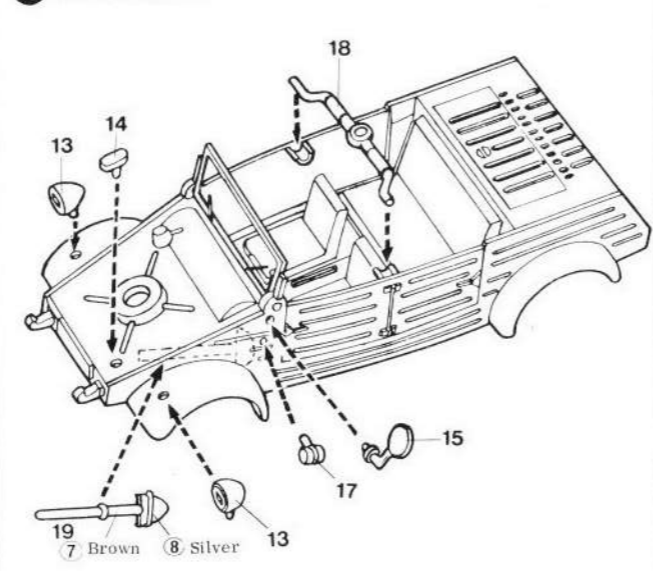

⑤ Parts Cement

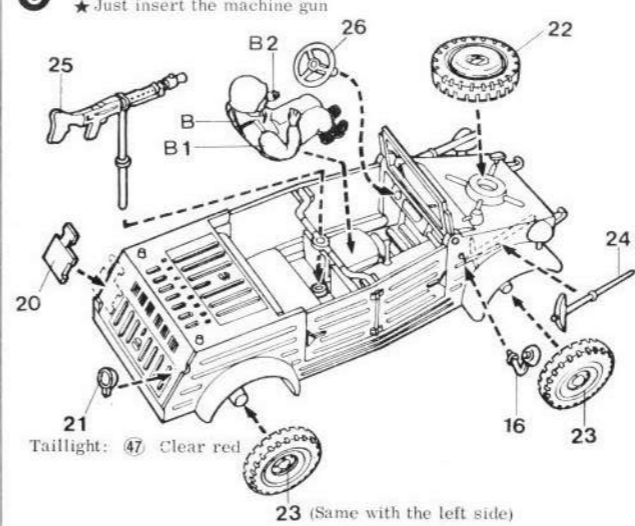

⑥ Hood Installation

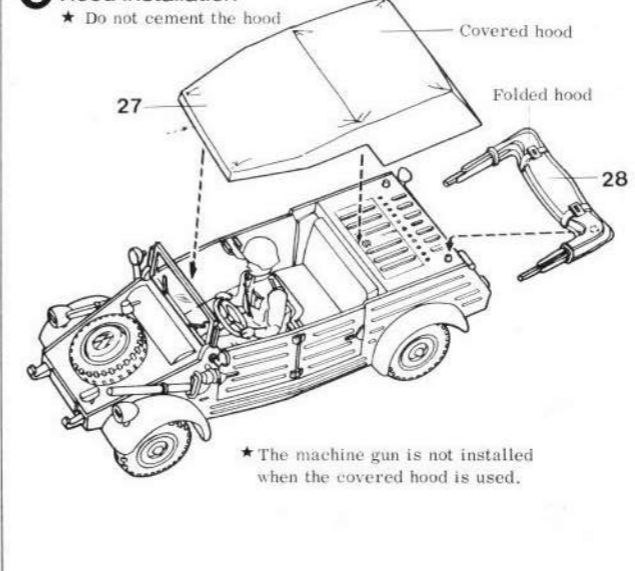

BMW Side-Car Assembly

① Parts Cement

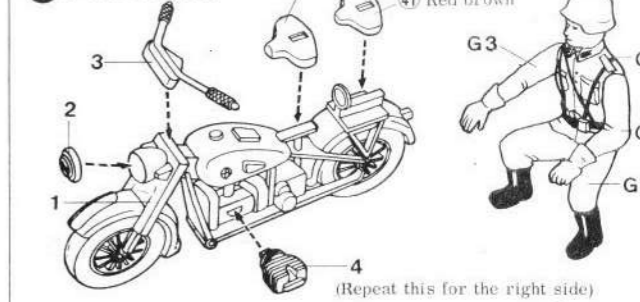

② Car Assembly

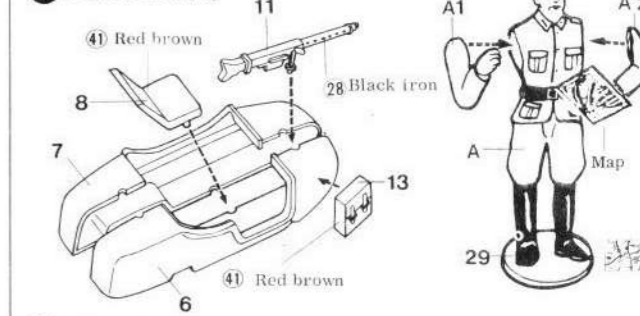

③ Chassis Assembly

