

Breguet Br.695AB.2 'Under the Vichy Government'

EN

In 1934, the French Air Ministry issued a competition for a heavy fighter aeroplane which called for a twin-engine configuration capable of carrying out a wide range of roles according to the actual equipment and the number of crew members. This aeroplane was to lead formations of single seat fighters, perform as a day escort fighter or even pursue enemy machines at night. The winner of the competition was the Potez 630 mainly because of the speed with which the designers put the project forward and the construction team managed to build the prototype. The other egg in the basket, the Br.690 developed by Breguet, was not wasted though. The Air Ministry issued yet another competition for a new aircraft category specified as Assault Bombardement 2, i.e. twin engine attack bomber aircraft, so Breguet's chief designer G. Ricard modified the design to match the new specifications. The prototype, first flown on 3 March 1938 was built as a three seater and surprised all concerned with its performance, mainly by the top speed which even surpassed the Potez 630. Eventually, the Armee de l'Air ordered production of a ground-attack version designated Br.691 AB2. The new Breguets, however, faced undercarriage strength issues and also their Hispano&Suiza 14Ab powerplants were quite unreliable. To overcome the trouble, it was decided to use a different type of engines, as was also the case with the Potez 63 series and the new subtype equipped with Gnome Rhone 14M radials was named Br.693AB.2, became the main production subtype of the Br.690 family of aeroplanes and was hurriedly put into service with operational attack units in the Spring of 1940. The Br.695AB.2 was a new version which was powered by US-built Pratt&Whitney Twin Wasp Junior engines and even though these engines were available only in clockwise-rotating variety and had a larger diameter, they finally turned the Breguet into a hi-performance attack machine. Unfortunately, only 10 of the Br.695AB.2 had been produced by the time France capitulated. Further versions, or rather just projects, as the Br.692 heavy fighter, Br.694 reconnaissance aircraft, Br.696 dive bomber, Br.697 heavy fighter, Br.698 Aeronavale dive bomber, Br.699 dive bomber or Br.700 heavy fighter either did not materialize at all or reached just a prototype stage. The training of new GBA attack units was drastically cut short by the outbreak of the war and subsequent German attack on France. GBA 1/54 and 11/54 units and later also GBA 1/51 and 11/51 were hurled into furious battles of May and June 1940. All these units suffered high losses both by anti aircraft artillery and Luftwaffe fighters. Breguets and their crew paid a high price for seeking the right attack tactics and also for operating during the enemy's air superiority. Following the German occupation of one part of France, the captured Breguets were transferred to the Luftwaffe and used for training purposes both in France and in Germany. Some machines managed to escape to the south and were assigned to the Vichy Air Force. When the rest of the France was seized in 1942, the Vichy Breguets were scrapped and only a handful of machines was sent to Italy where they went on to serve for short period as trainers.

Wingspan: 15.365 m, length: 9.415 m, max. speed at ground level: Br.693 360 km/h, Br.695 393 km/h, service ceiling: 9,500 m, range: 1,450 km.

CZ

Francouzské ministerstvo letectví vypsalo v roce 1934 soutěž na těžký stíhací letoun. Zadání požadovalo dvoumotorový letoun, který měl být, s různým vybavením a různými počty členů osádky, schopen nasazení jako vedoucí stroj formací jednomístných strojů, denní doprovodný stíhač a noční stíhač. Tuto soutěž vyhrál, hlavně díky rychlosti jakou byl navrhnout a postaven prototyp, Potez 630. Návrh firmy Breguet vyvíjený pod označením Br.690, ale nezapadl. Ministerstvo letectví vypsalo soutěž na novou kategorii letadel označenou Assault Bombardement 2 – požadovalo dvoumotorové dvoumístné bitevní letadlo. Šéfkonstruktor typu Br.690 G. Ricard upravil projekt podle nových požadavků. První prototyp, zalétaný 23. 3. 1938, byl postaven ještě v podobě třímístné stíhačky. Překvapil svými výkony, hlavně rychlostí, která byla vyšší než u Potezu 630. Armée de l'Air objednalo si novou bitevní verzi Br.691AB.2. U nových Breguetů se ale objevily problémy s pevností podvozků a hlavně s poruchovostí motoru Hispano & Suiza 14Ab. Řešením bylo použití jiných motorů, podobně jako u řady Potez 63 dostala další verze označená Br.693AB.2 motory Gnome-Rhone 14M. Ta se stala hlavní sériovou verzí a byla urychleně dodávána novým bitevním jednotkám Armée de l'Air na jaře roku 1940. Vyrábět se začala i verze Br.695 AB.2 s americkými motory Pratt & Whitney Twin Wasp Junior. Tyto spolehlivé motory, přesto, že měly větší průměr a byly pouze pravotočivé, daly Breguetu výkon konečně odpovídající požadavkům na kvalitní bitevní stroj. Do kapitulace Francie však bylo vyrobeno jen 10 ks Br.695AB.2. Další verze jako Br.692 (těžký stíhač), Br.694 (průzkumná verze), Br.696 (střemhlavý bombardér), Br.697 (těžký stíhač), Br.698 (střemhlavý bombardér pro Aeronavale), Br.699 (střemhlavý bombardér) a Br.700 (těžký stíhač) skončily buď již ve fázi projektu, nebo byly postaveny jen v prototypu. Výcvik nových bitevních jednotek GBA drasticky zkrátilo vypuknutí války a posléze útok na Francii. Do urputných bojů v květnu a červnu 1940 byly vrženy skupiny GBA 1/54 a 11/54 a posléze 1/51 a 11/51. Všechny utrpěly vysoké ztráty, jak protiletadlovou palbou, tak akcemi stíhaček Luftwaffe. Breguety zaplatily dan za hledání taktiky bitevních útoků a za útoky během vzdušné převahy nepřítele. Po obsazení části Francie byly ukořistěné Breguety používány k výcviku u Luftwaffe, jak ve Francii, tak v Německu. Ty, které byly evakuovány na jih byly zařazeny do letectva Vichy. Po obsazení zbytku Francie v roce 1942 byly vichistické Breguety sešrotovány, pouze několik z nich se dostalo do Itálie, kde opět posloužily, byť jen krátce k výcviku.

Technická data: rozpětí 15,365 m, délka: 9,415 m, max. rychlost při zemi: Br.693 360 km/h, Br.695 393 km/h, dostup: 9 500 m, dolet: 1 450 km.

Parts List 1/2

A

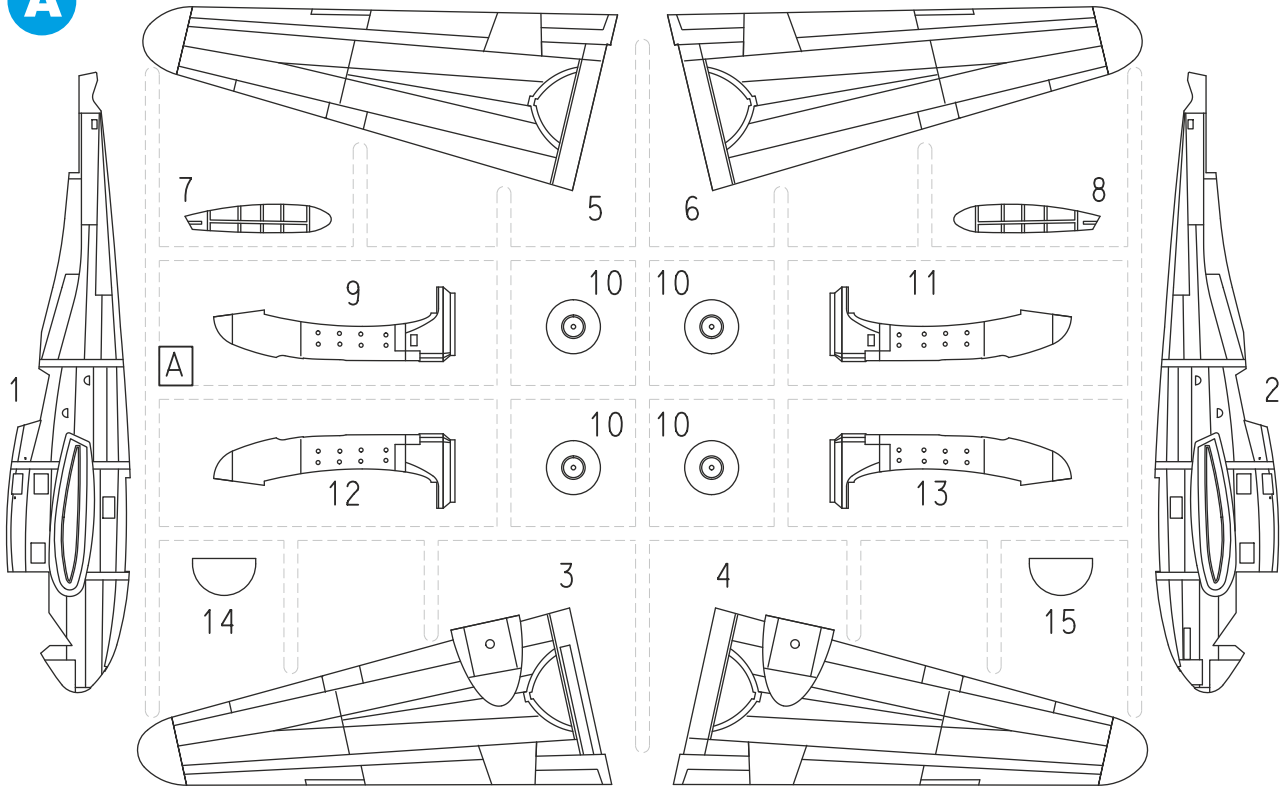

B

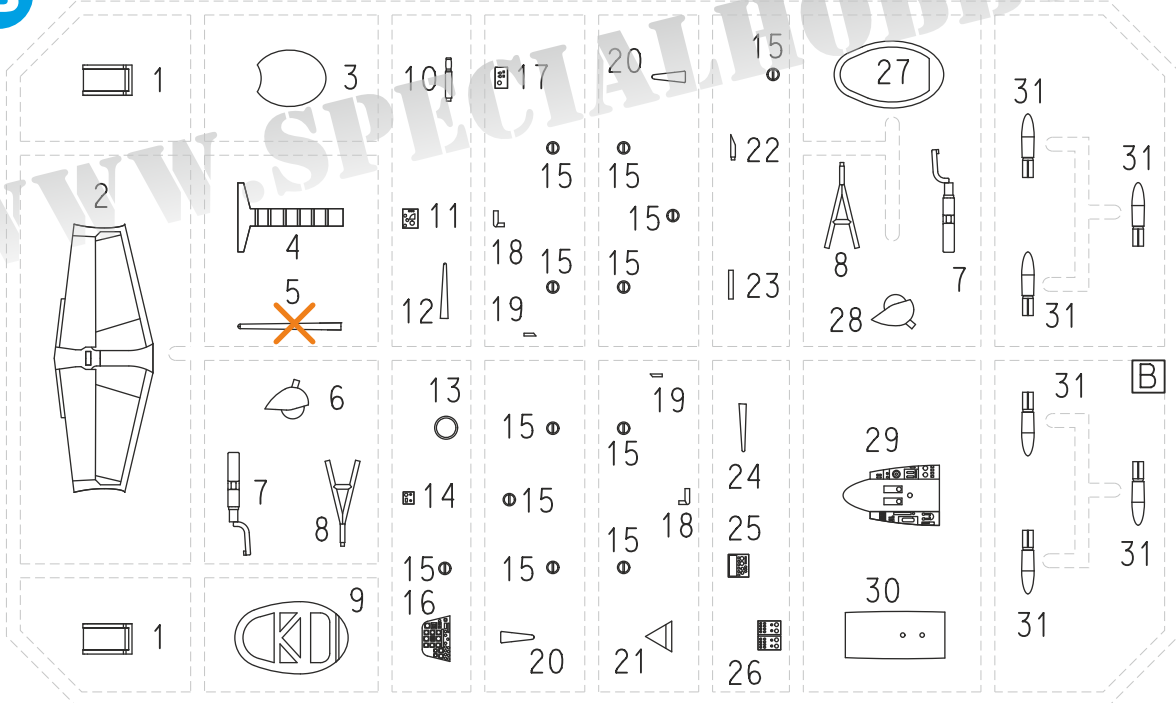

not to be used

SYMBOLS



OPTIONAL
MOŽNOST VOLBY
NACH BELIEBEN
OPTION



INSTANT CYANOACRYLATE GLUE
POUŽIT KYANOAKRYLÁTOVÉ LEPIDLO
ZYANOAKRYLÁTKLEBER
ADHÉSIF CYANOACRYLAT



BEND
OHNOUT
BIEGEN
COURBER



SCRATCH BUILD
ZHOVOVIT NOVĚ
FERTIGSTELLEN
ACHEVER



CUT OFF/DRILL
ŘEZAT/VRTAT
ENTFERNEN
DETACHER



COLOUR
NATRÍT
FARBEN
PEINDRE

Parts List 2/2

D

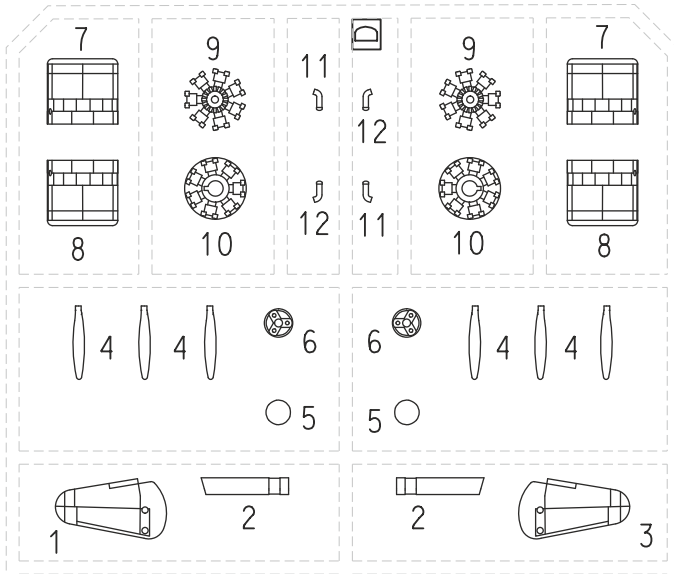

Clear Parts (CP)

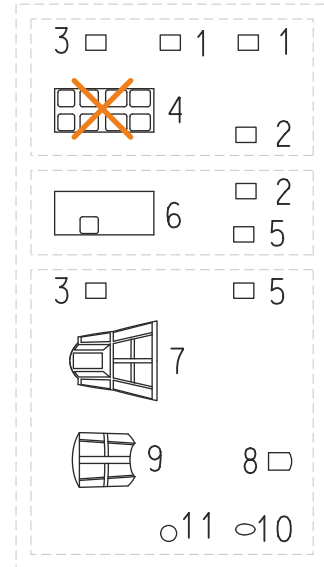

PUR Part (PUR)

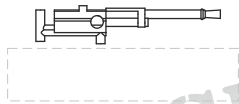
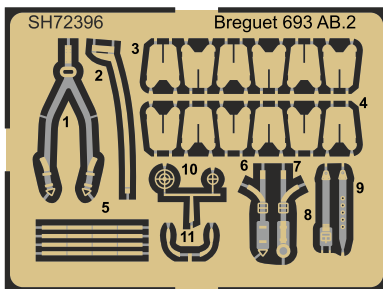

Photo Etched Parts (PE)



Barvy GUNZE/ GUNZE Colour No.

A	Aluminium / hliník	H8/C8
B	Black / černá	H12/C33
C	Steel / ocel	H18/C28
D	Linen (Tan) / plátno	H27/C44
E	Tire Black / barva pneu	H77/C137
F	Light Grey / světle šedá	H325/C325
G	Grayish blue / tm. modrošedá	H337/C337
H	Dark Metal / tmavý kov	H28/C78
I	Burnt Iron / opálený kov	H76/C61
J	Clear Red / červená čírá	H90/C47
K	Clear Green / zelená čírá	H94/C138

X not to be used



OPTIONAL
MOŽNOST VOLBY
NACH BELIEBEN
OPTION



INSTANT CYANOACRYLATE GLUE
POUŽIT KYANOAKRYLÁTOVÉ LEPIDLO
ZYANOAKRYLÁTKLEBER
ADHÉSIF CYANOACRYLAT

SYMBOLS



BEND
OHNOUT
BIEGEN
COURBER



SCRATCH BUILD
ZHOTOVIT NOVÉ
FERTIGSTELLEN
ACHEVER



CUT OFF/DRILL
ŘEZAT/VRTAT
ENTFERNEN
DETACHER



GSI **A**
COLOUR
NATRÍT
FARBEN
PEINDRE

1

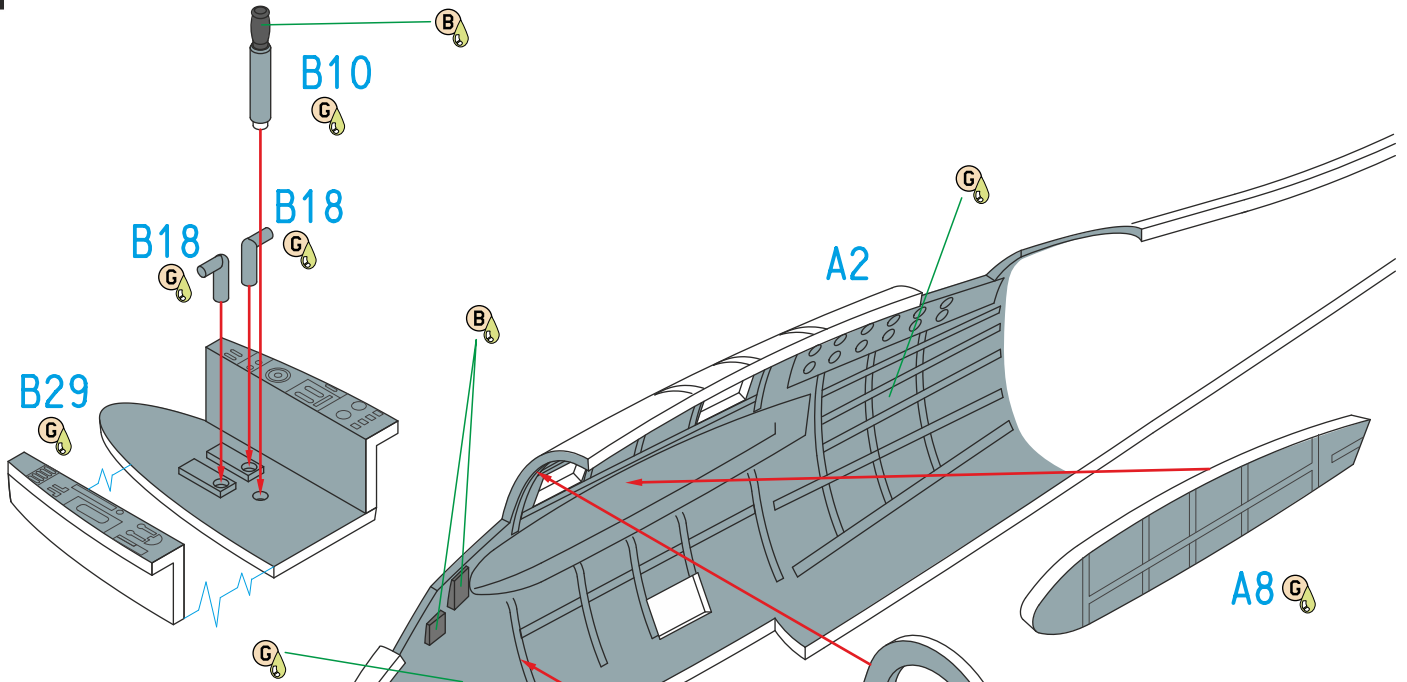

2

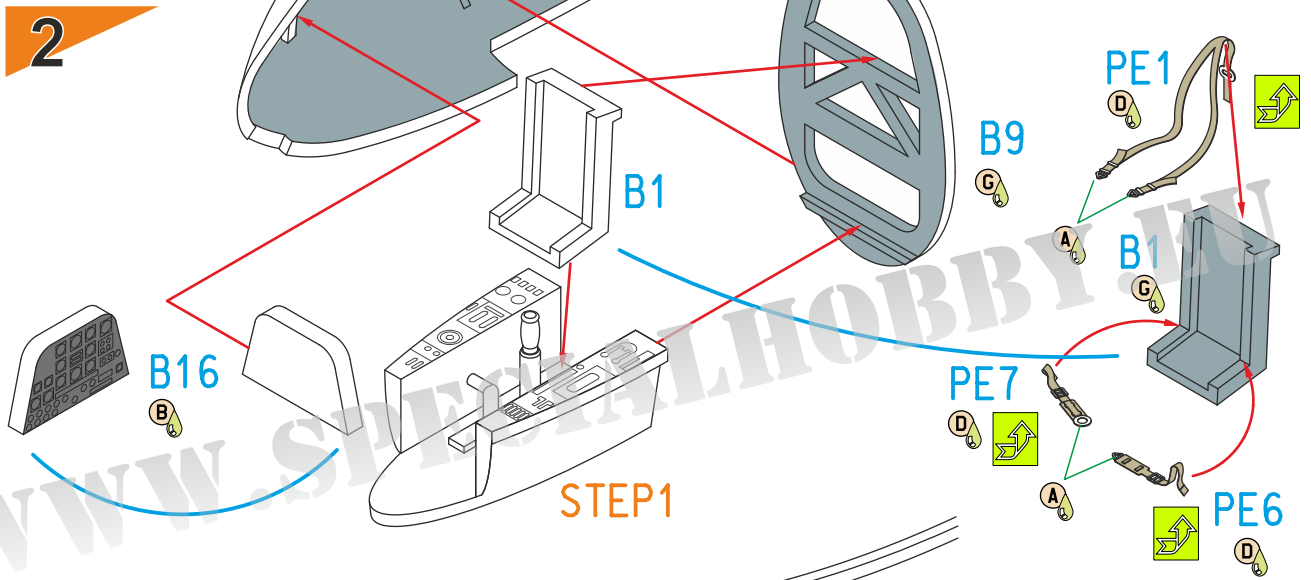

STEP1

3

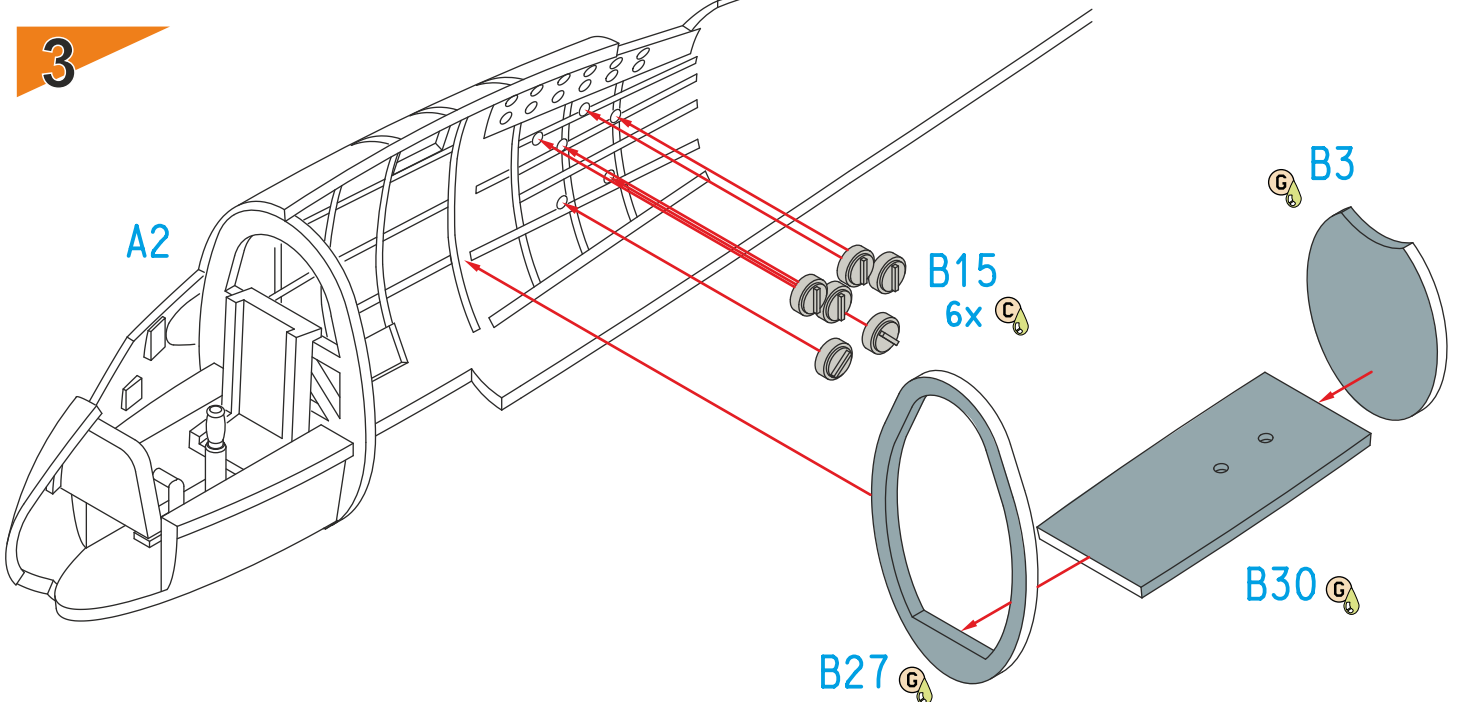

4

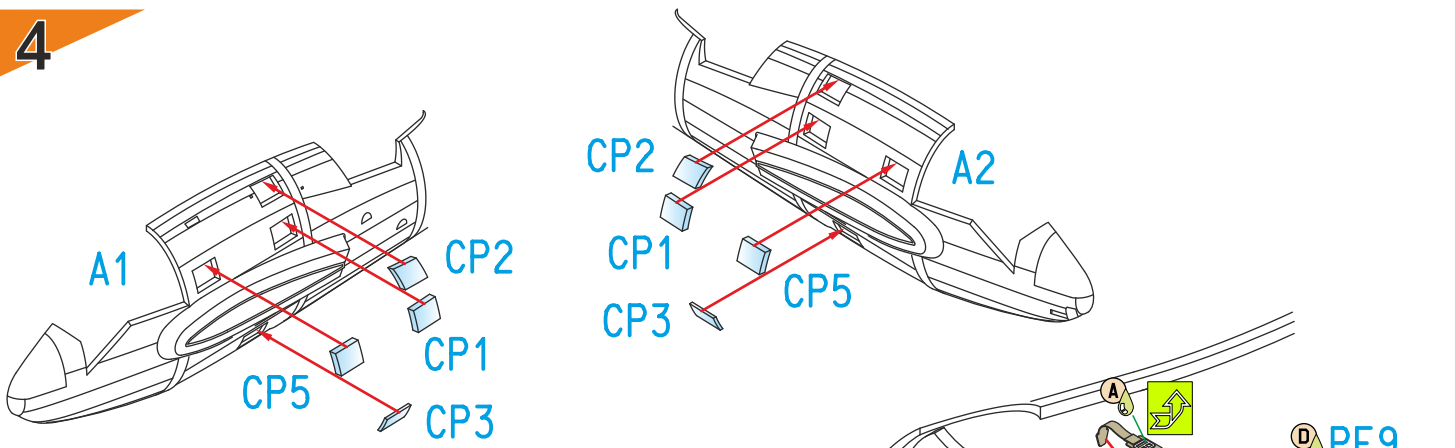

5

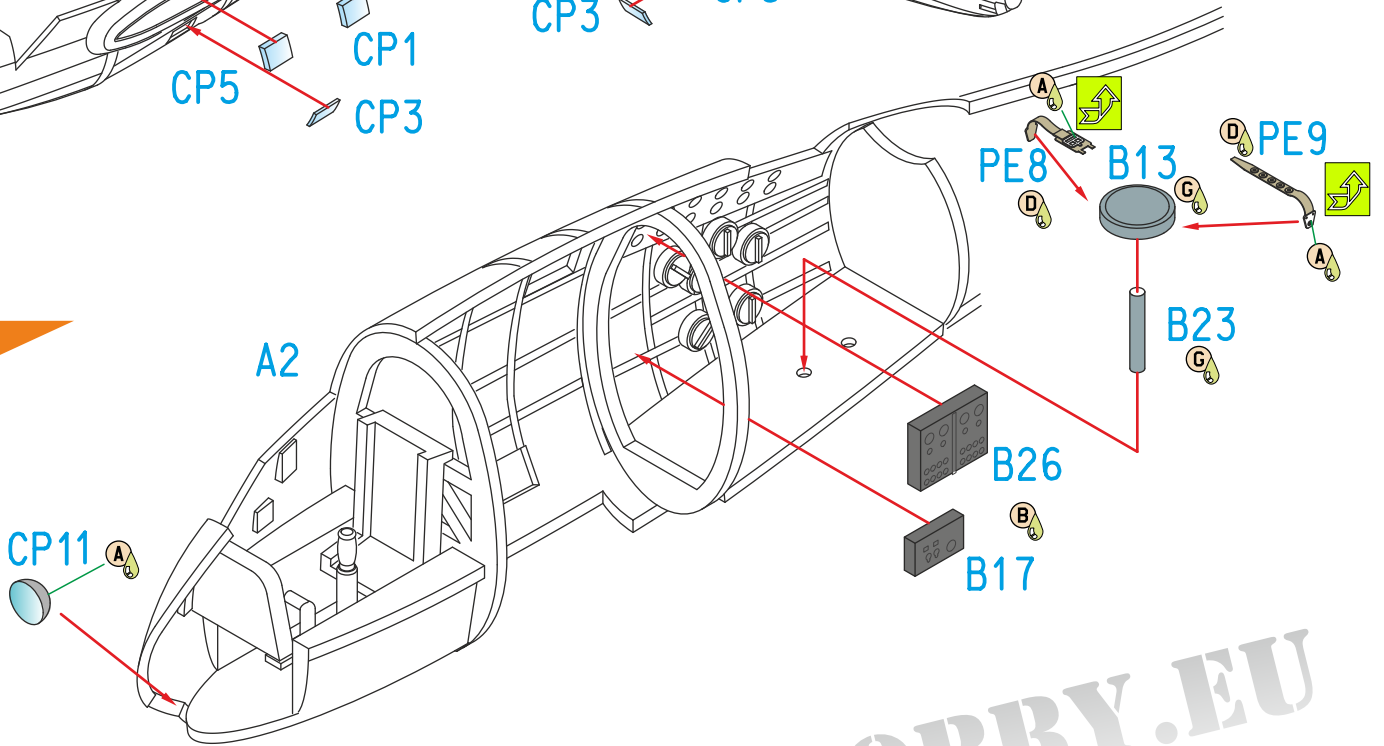

6

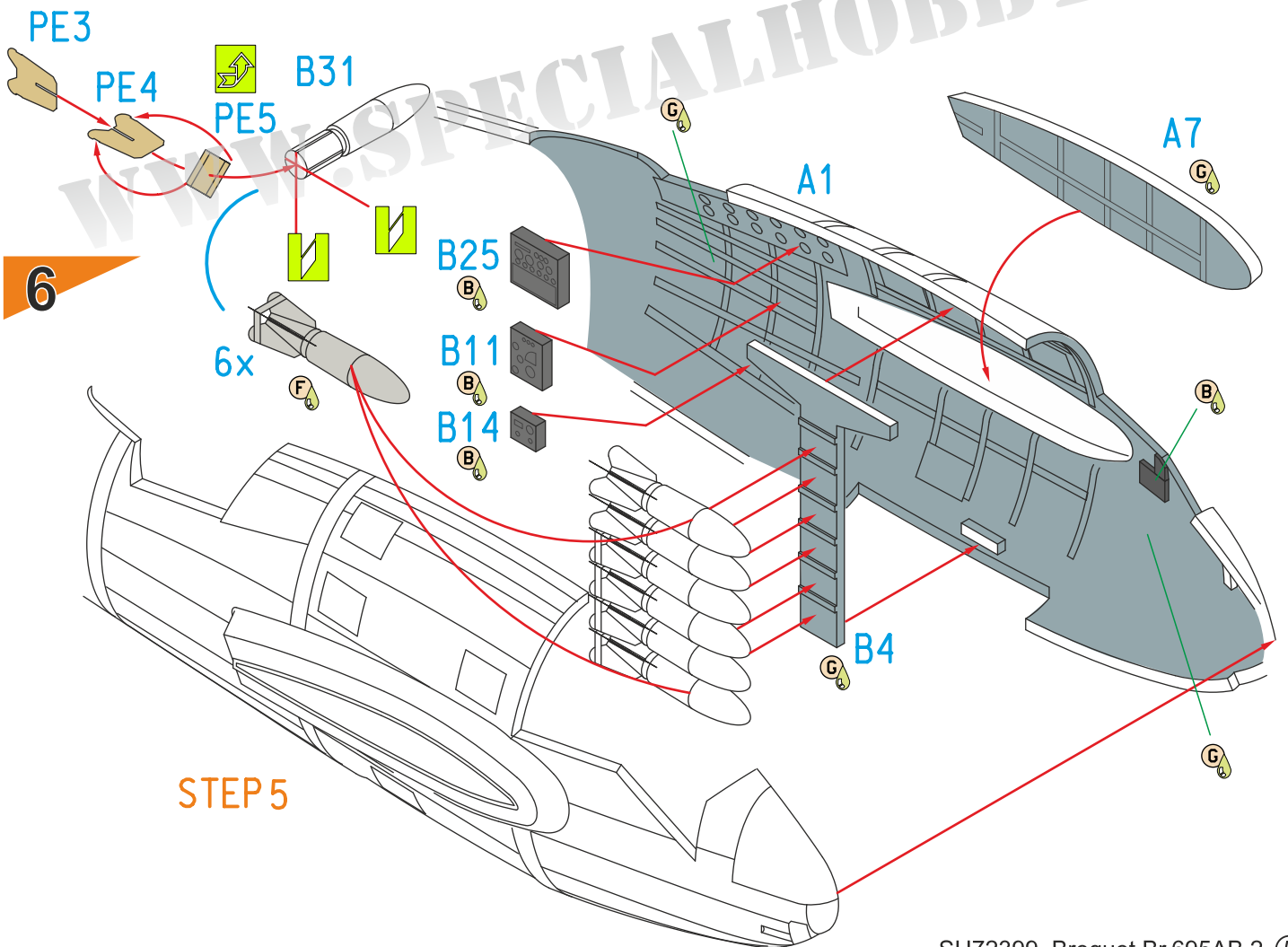

STEP 5

7

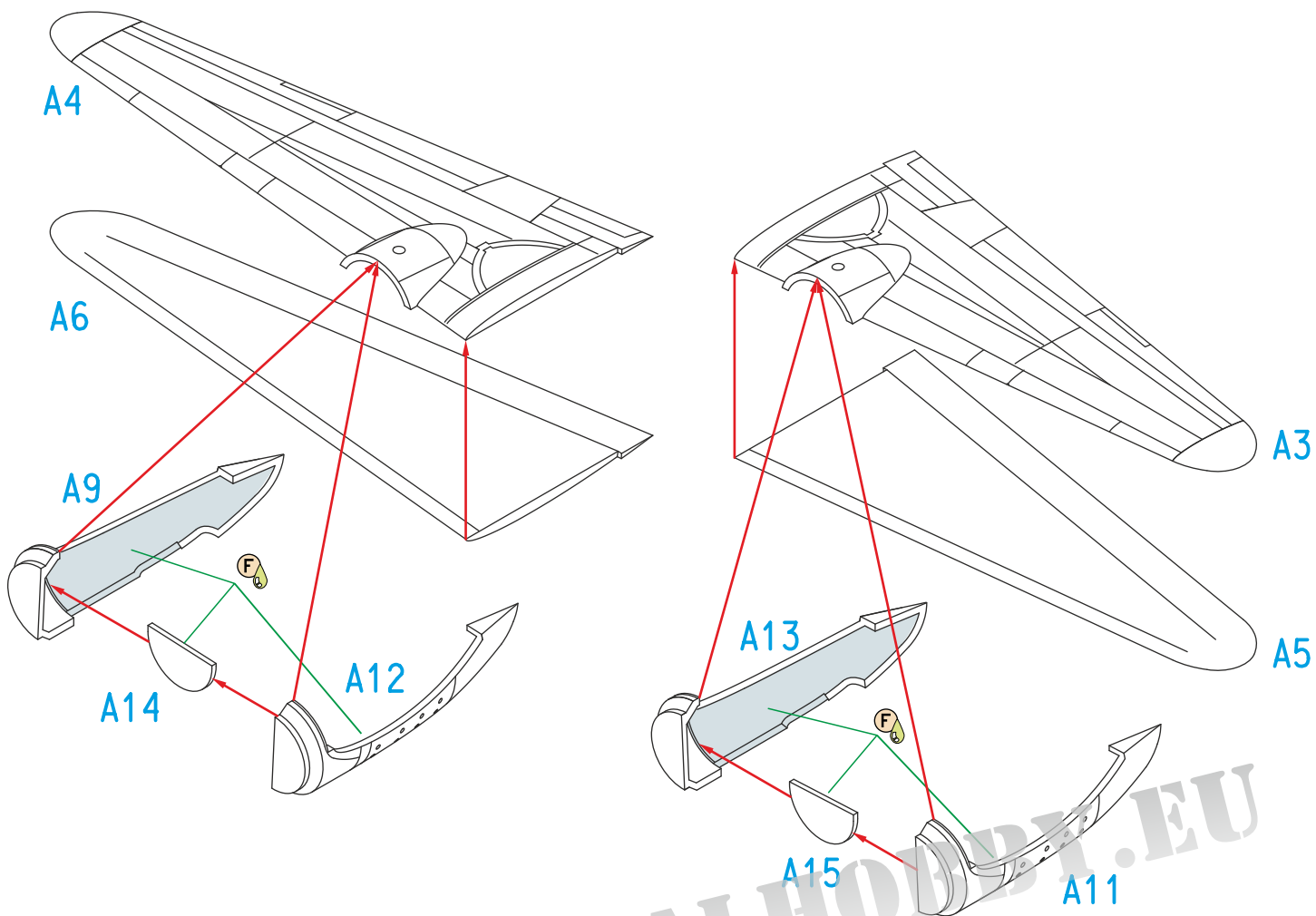

8

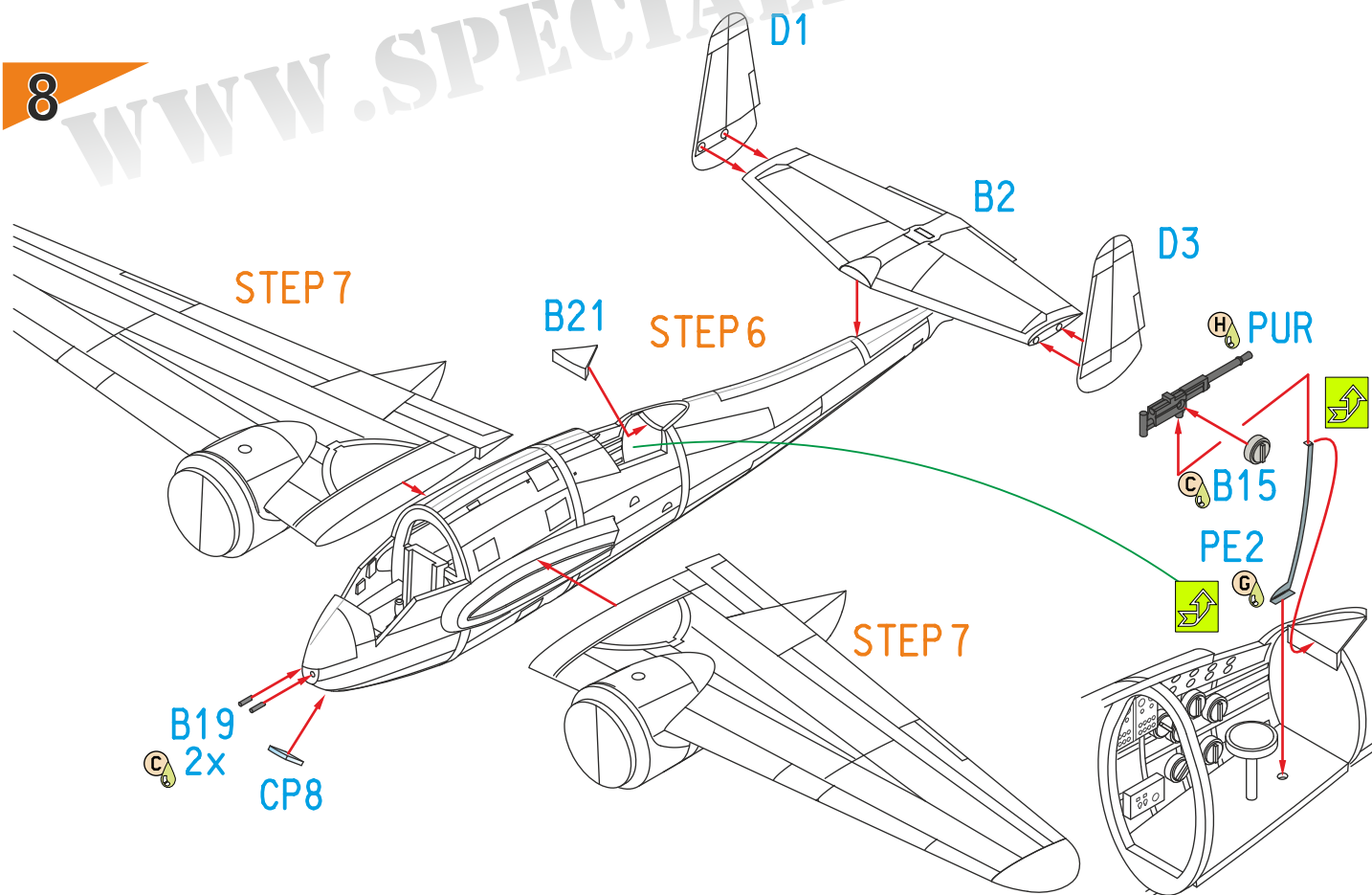

9 2x

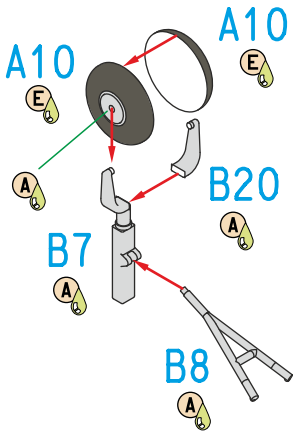

10

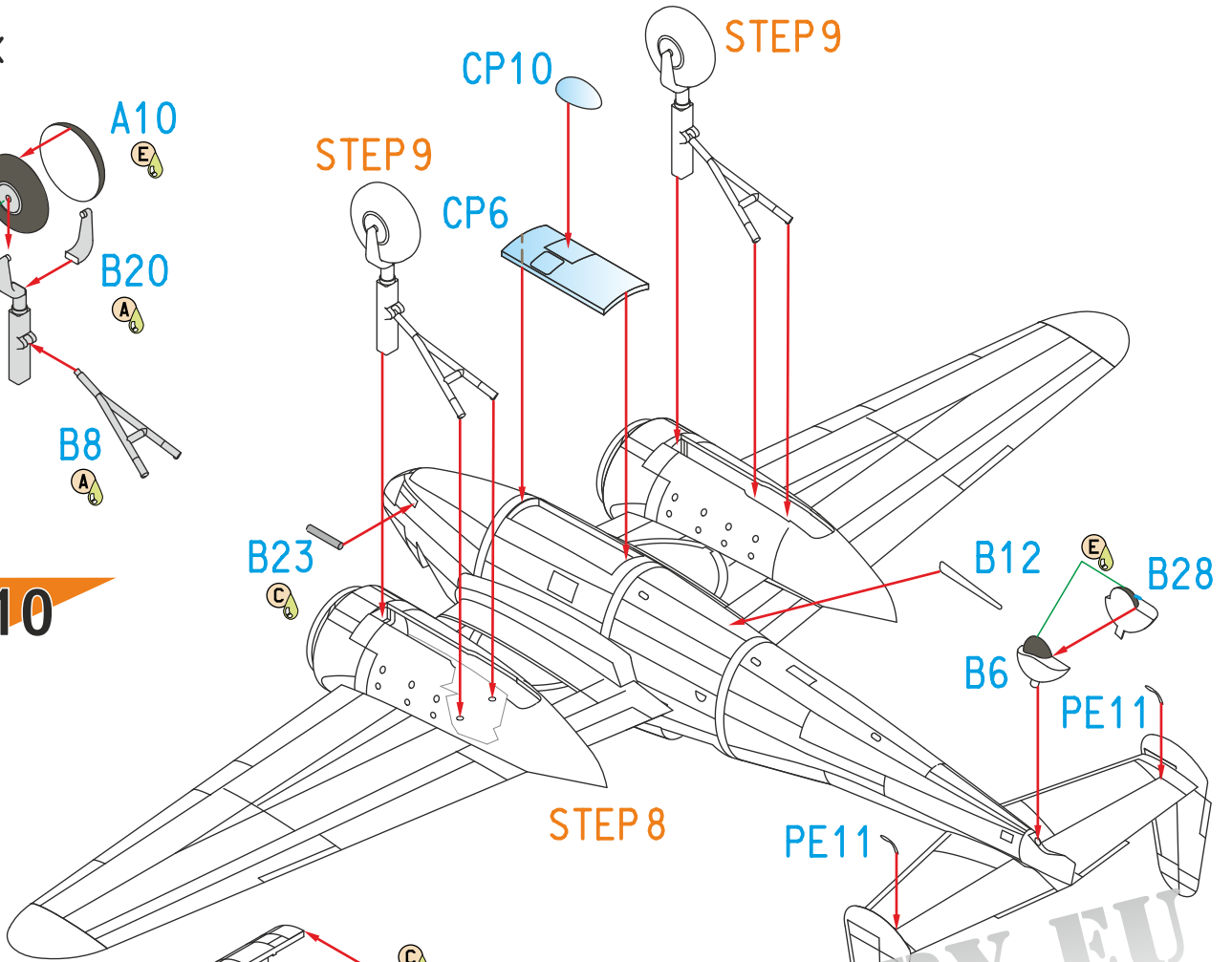

11

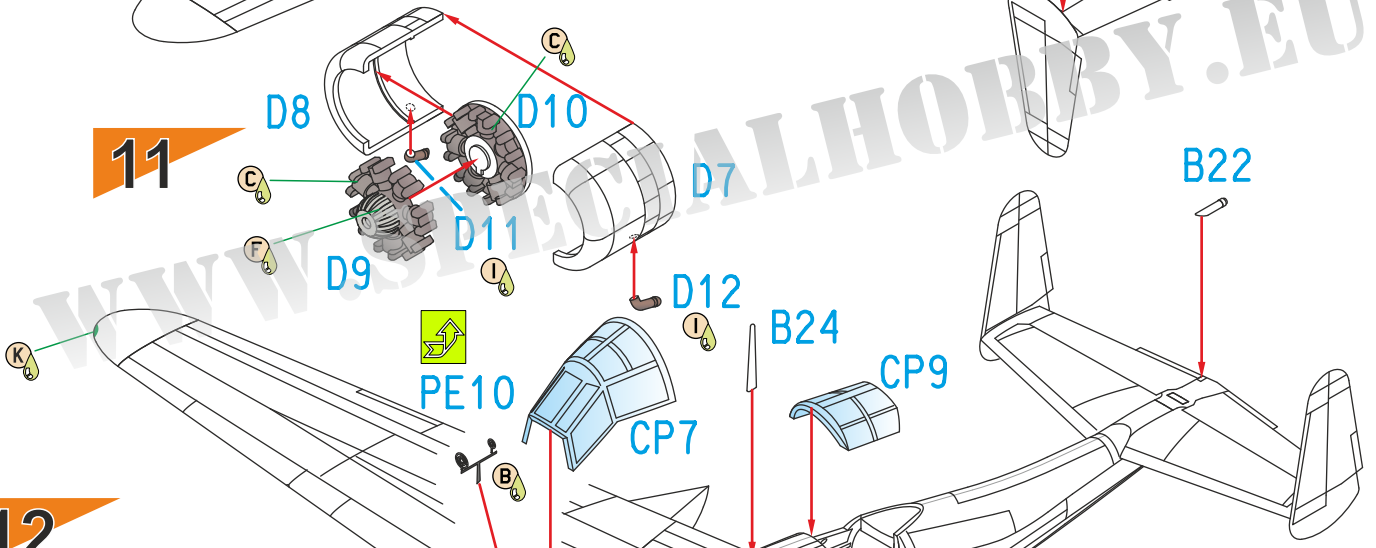

12

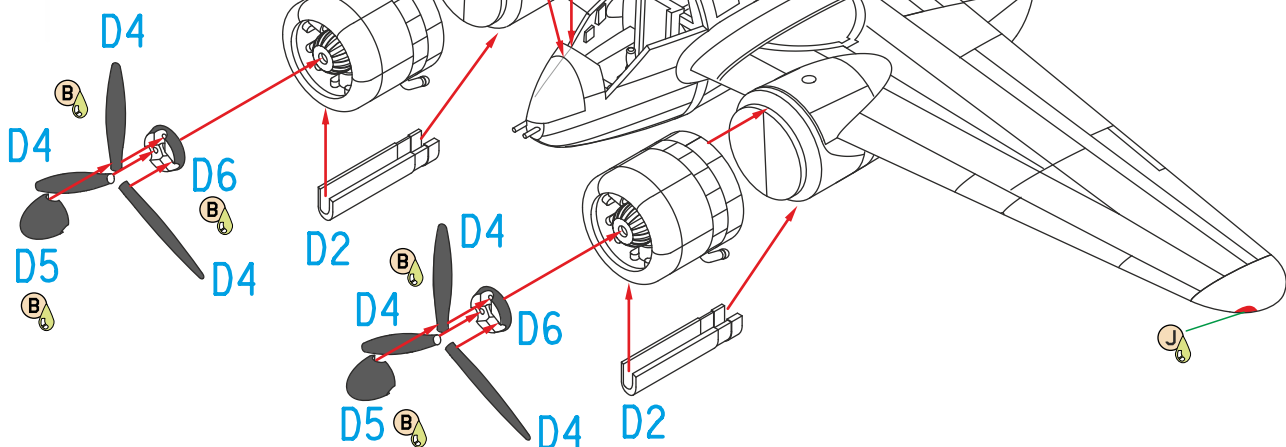

Breguet Br.695AB.2, No.8 / Black "1", 1. escadrille GBA I/51, Lézignan, Spring 1941. This machine was used by the unit's commanding officer Cne d'Artemare's.

Breguet Br.695AB.2, No.8 / černá 1, 1. escadrille GBA I/51, Lézignan, léto 1941. Na stroji létal velitel jednotky Cne d'Artemare.

CAM. A



- | | | | | | |
|------------------------------------|---|---|--|-----------------------------------|----------------------------------|
| A Khaki
Khaki
H73/C23 | B Dark Brown
Tmavá hnědá
H17/C29 | C Dark Grey-Blue
Tmavě šedomodrá
H307/C307 | D Sky Grey-Blue
Nebeská šedomodrá
H337/C337 | E Yellow
Žlutá
H4/C4 | F Red
Červená
H3/C3 |
|------------------------------------|---|---|--|-----------------------------------|----------------------------------|



Breguet Br.695AB.2, most probably No.95 / White "V", 4. escadrille
GBA II/51, Toulouse-Francazal, late June 1940.

Breguet Br.695AB.2, pravděpodobně No.95 / bílá V, 4. escadrille
GBA II/51, Toulouse-Francazal, konec června 1940.

CAM. B

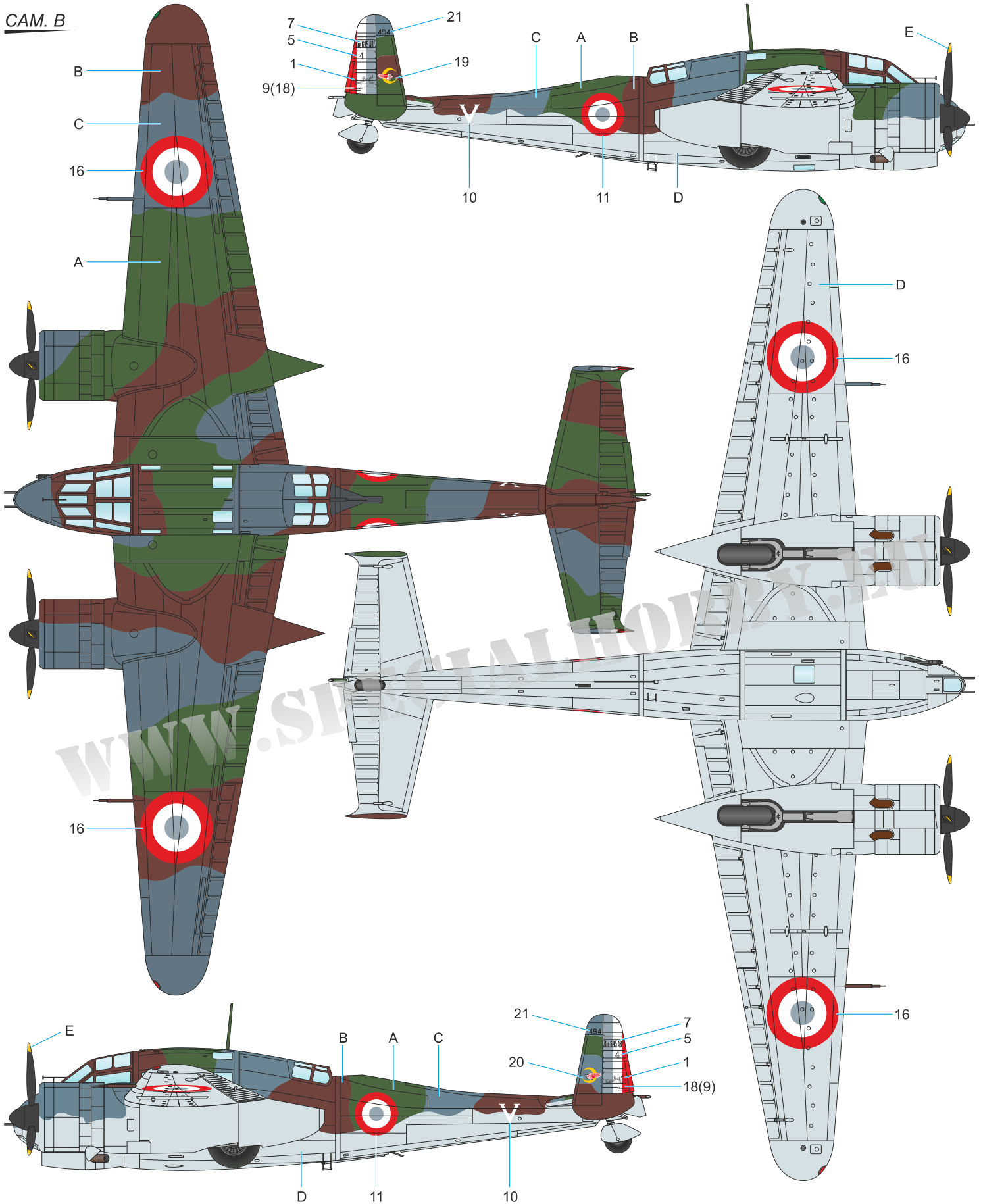

- | | | | | | | | | | |
|---|---------------------------|---|--------------------------------------|---|--|---|---|---|--------------------------|
| A | Khaki
Khaki
H73/C23 | B | Dark Brown
Tmavá hnědá
H17/C29 | C | Dark Grey-Blue
Tmavě šedomodrá
H307/C307 | D | Sky Grey-Blue
Nebeská šedomodrá
H337/C337 | E | Yellow
Žlutá
H4/C4 |
|---|---------------------------|---|--------------------------------------|---|--|---|---|---|--------------------------|



SH72399 Breguet Br.695AB.2

Breguet Br.695AB.2, No.51 / White "4", 3. escadrille GBAI I/51, Orléans-Bricy, June 1940.

Breguet Br.695AB.2, No.51 / bílá 4, 3. escadrille GBAI I/51, Orléans-Bricy, červen 1940.

CAM. C

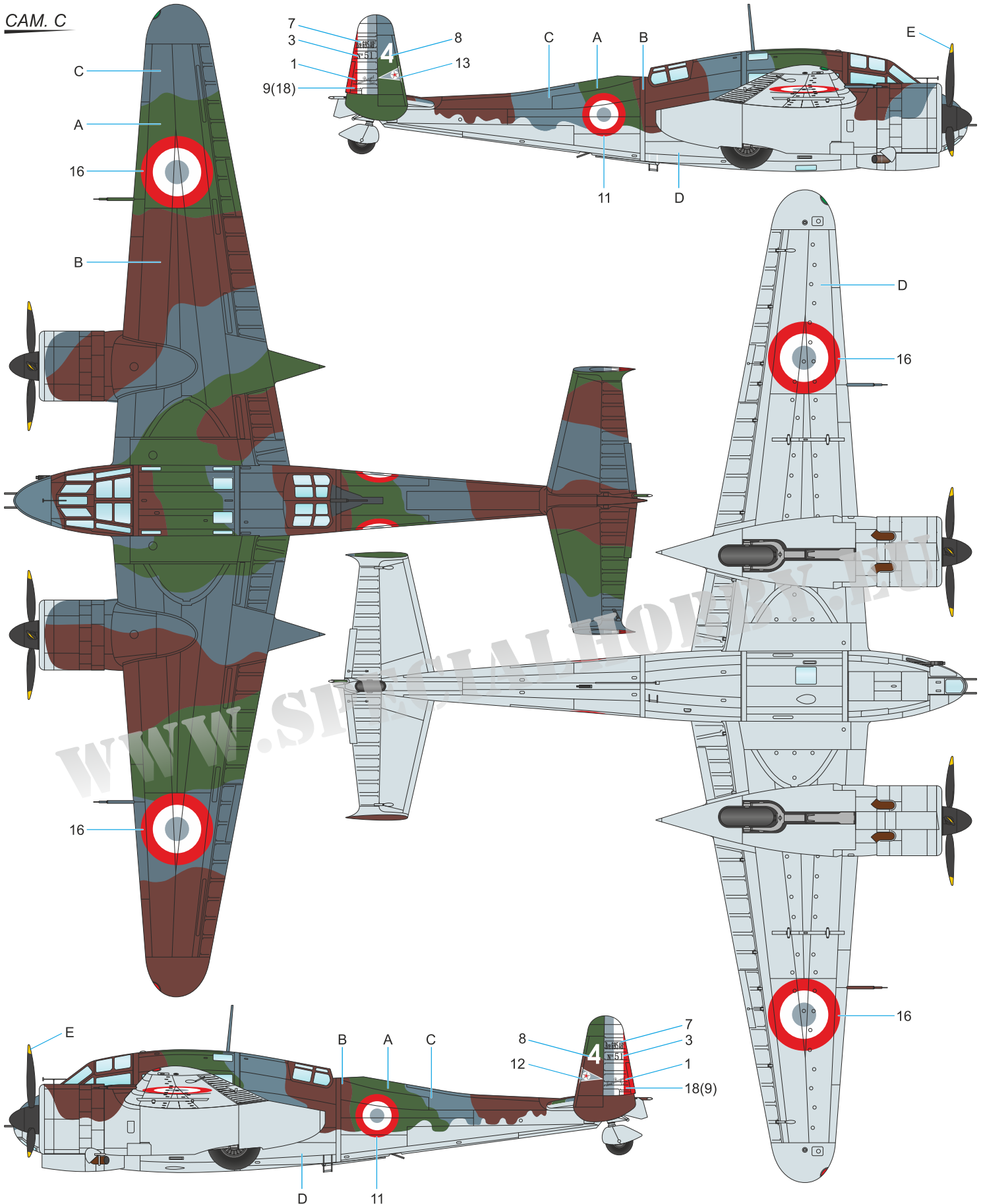

A Khaki
Khaki
H73/C23

B Dark Brown
Tmavá hnědá
H17/C29

C Dark Grey-Blue
Tmavě šedomodrá
H307/C307

D Sky Grey-Blue
Nebeská šedomodrá
H337/C337

E Yellow
Žlutá
H4/C4



SH72399 Breguet Br.695AB.2