

Clear Prop!

I-16 TYPE 5

IN THE SKY OF SPAIN

1:72

model # CP72023

STARTER



scale model kit

SPAN: 125,2 mm

LENGTH: 84,5 mm

NUMBER OF PARTS: 93 pcs

- 1** stages of assembly
- ?** optional
- A** variants of assembly
- glue by super glue
- A1** part number
- do not glue
- fill with putty
- make a hole
- 1** apply decals
- detach with knife
- 1** apply the adhesive mask
- paint
- bend
- repeat the operation N times

Role	Fighter
National origin	Soviet Union
Manufacturer	USSR, Plant No. 21, Plant No. 39, Plant No. 153, Plant No. 458
First flight	30 December 1933 (TsKB-12)
Primary users	Soviet Air Force, Spanish Republican Air Force, Chinese Nationalist Air Force
Produced	November 1934 – 1942
Number built	10,292 (6,848 fighters and 3,444 trainers)

I-16 (TsKB-12) - a Soviet single-engine monoplane fighter of the 1930s, created at the Central Design Bureau by a team led by aircraft designer Nikolai Polikarpov. One of the world's first mass-produced monoplane fighters with retractable landing gear in flight. The aircraft had a mixed design. The serial production of the aircraft, originally with the M-22 engine, started in 1934, and really unfolded only the next year. In 1935, it became possible to install M-25 engines on the aircraft, which were a Soviet copy of the American Wright-Cyclone F-3. The production of these engines was launched at the newly built aircraft factory No.19 in Perm. In 1935, using often American parts, the plant produced 660 M-25 engines. Some of these engines were intended for the I-16. In general, this aircraft was very reminiscent of the third prototype with the Wright-Cyclone F-3. However, the engine cowling has changed somewhat and received frontal blinds, which have become a characteristic feature of this aircraft. At production plant No.21 in Gorky, the aircraft received the designation type 5 and became the most massive single-seat modification of the I-16. Until the end of 1937, more than 2,500 planes were built. I-16 type 5 fought in Spain, China, were widely used at the initial stage of the Second World War

REQUIRED PAINTS



A A.MIG-0080
AMT-4 GREEN



B A.MIG-0046
AMT-6 BLACK



C A.MIG-0224
SKY LINE BLUE



D A.MIG-0046
BLACK



E A.MIG-122
BONE



F A.MIG-0191
POLISHED
STEEL



G A.MIG-0195
SILVER



H A.MIG-0033
TIRE BLACK



I A.MIG-0202
DECK TAN



J A.MIG-0187
PALE BURNT
METAL



K A.MIG-0125
ORANGE YELLOW



L A.MIG-0049
RED



M A.MIG-0205
STEEL GRAY



N A.MIG-0050
WHITE



AMMO
by MIG Jimenez

THIS MODEL IS PRODUCED FOR EXPERIENCED MODELERS OVER 14 YEARS

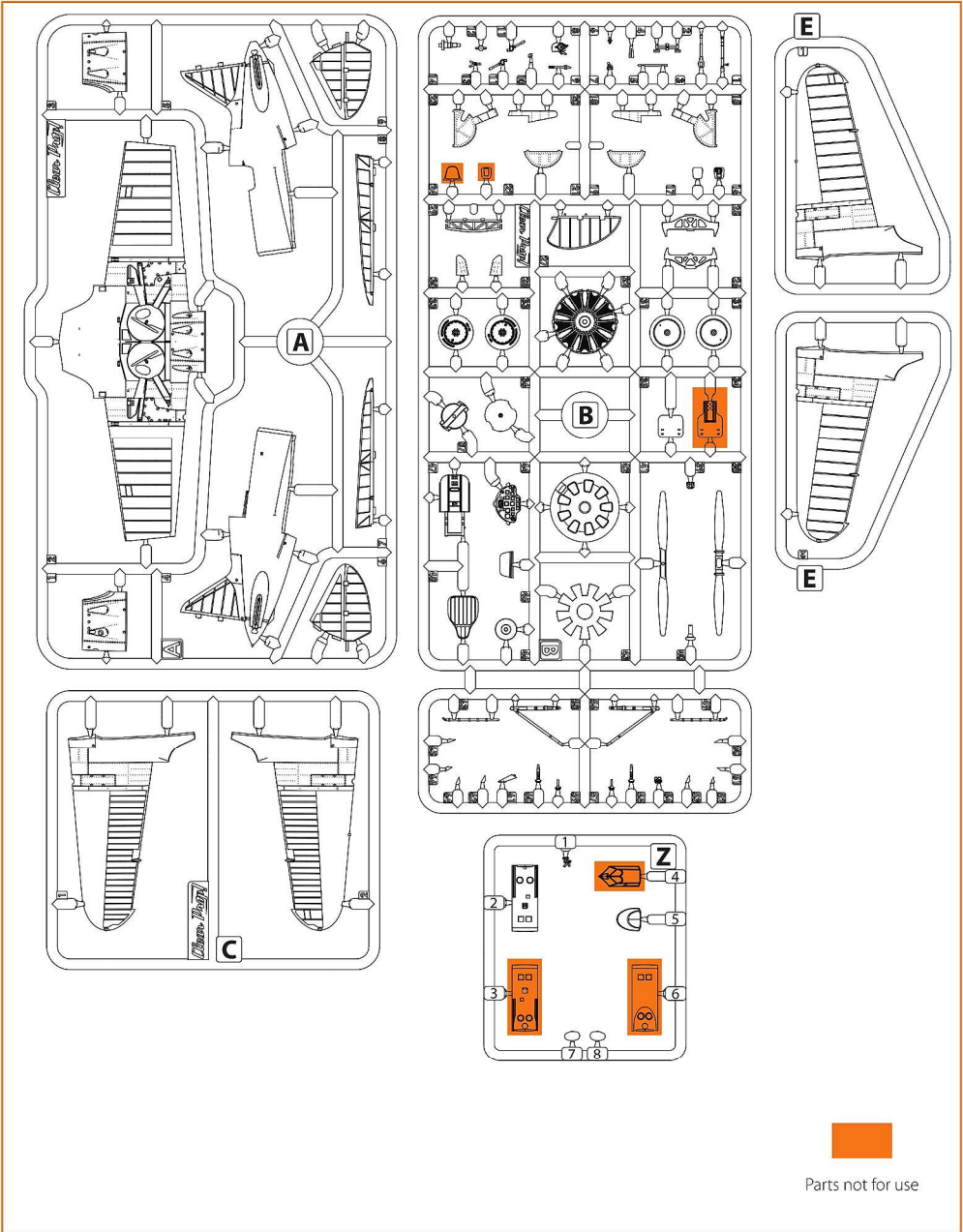

Parts not for use

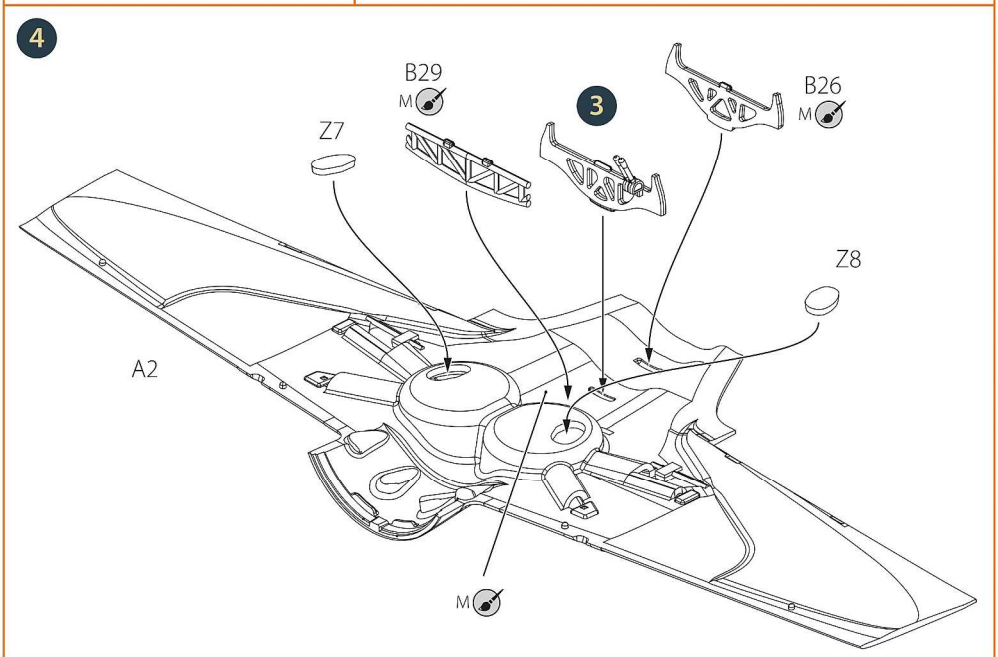
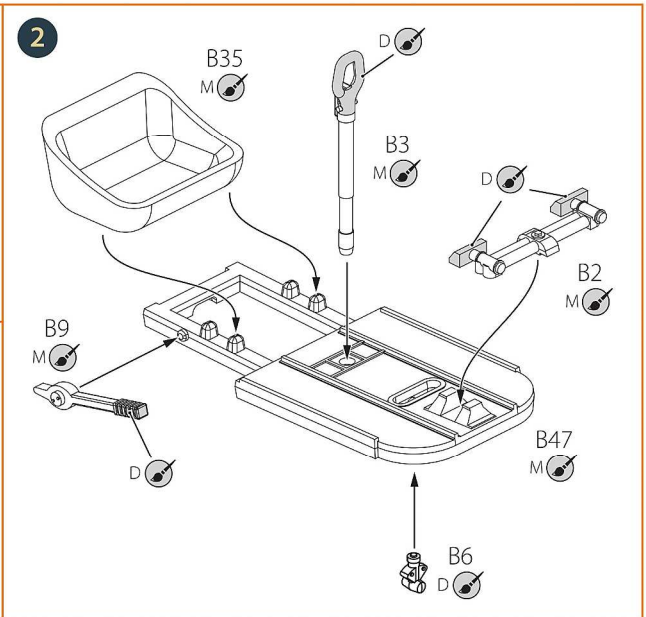
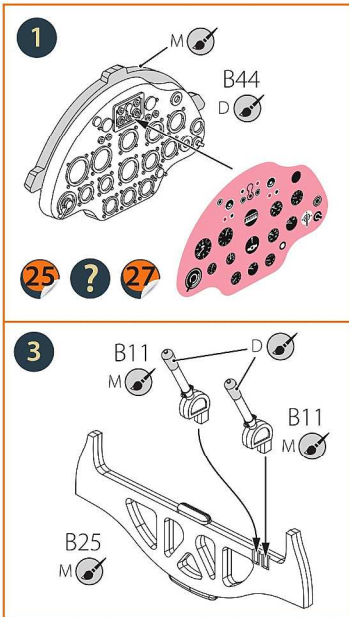

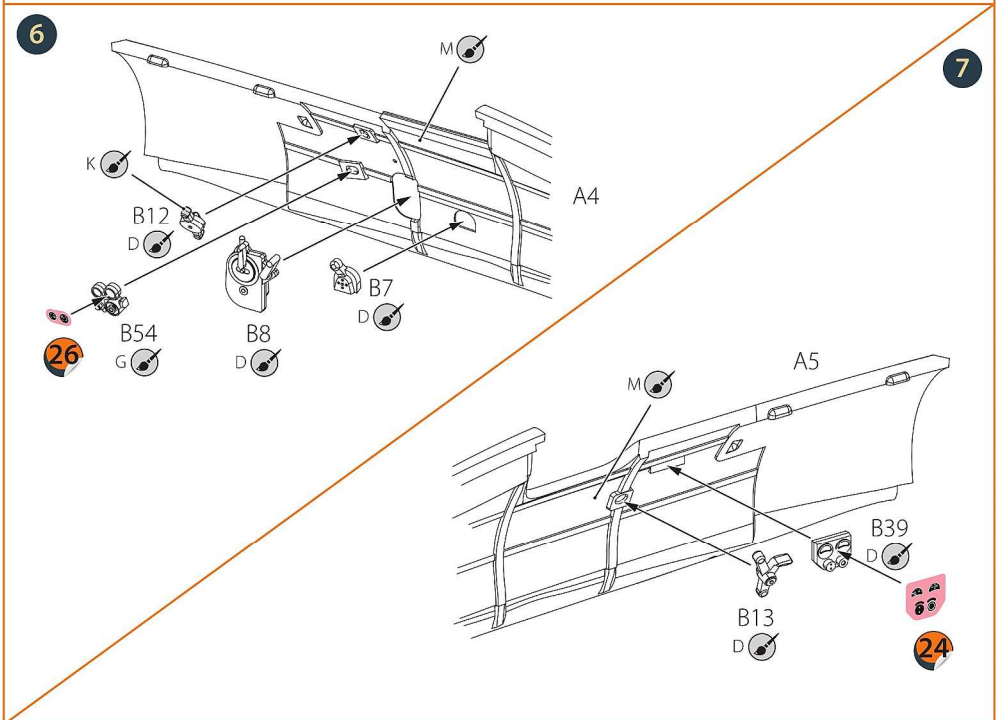
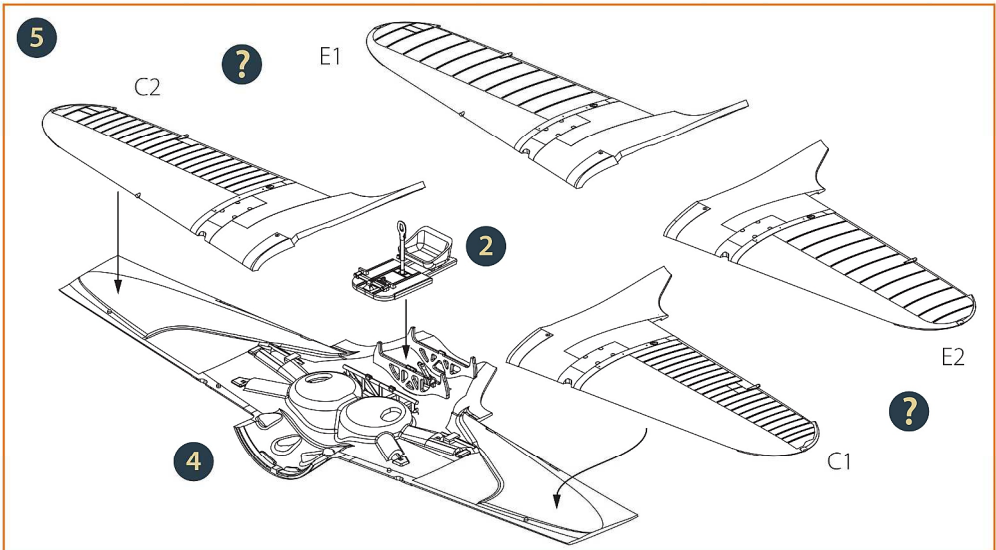

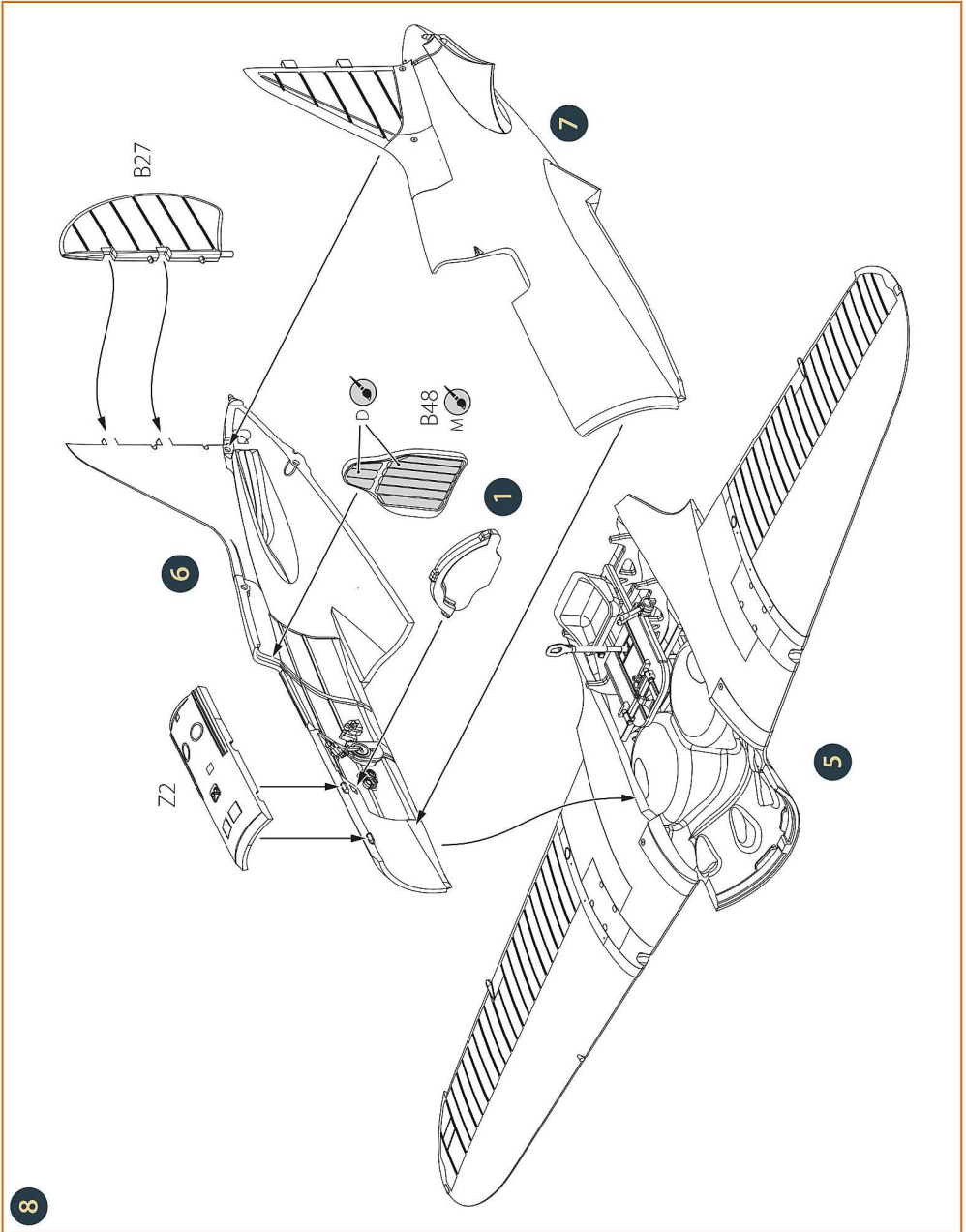

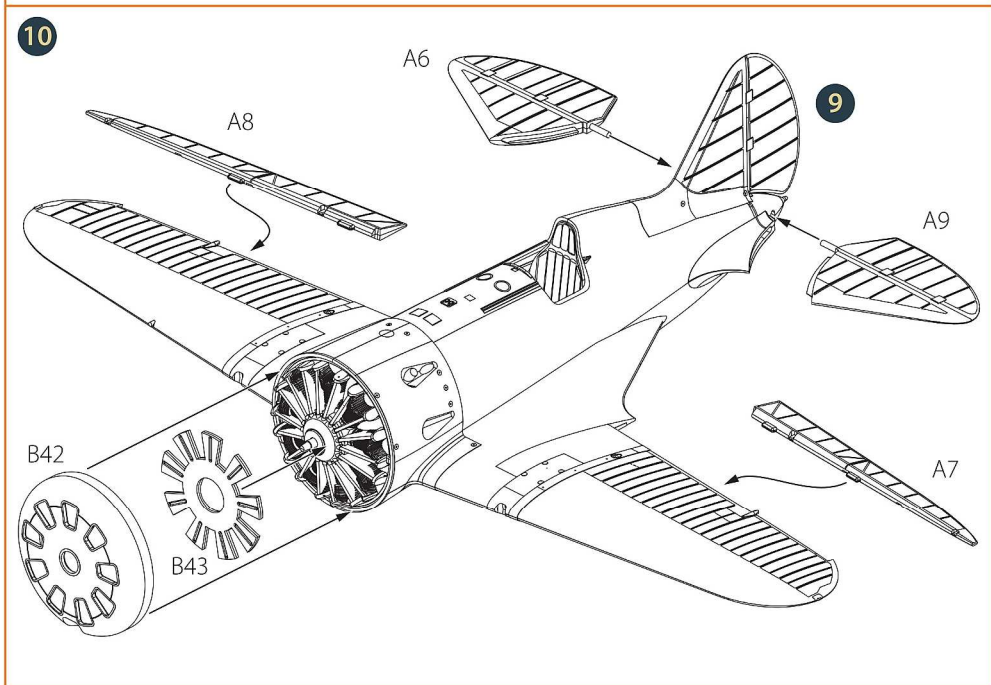
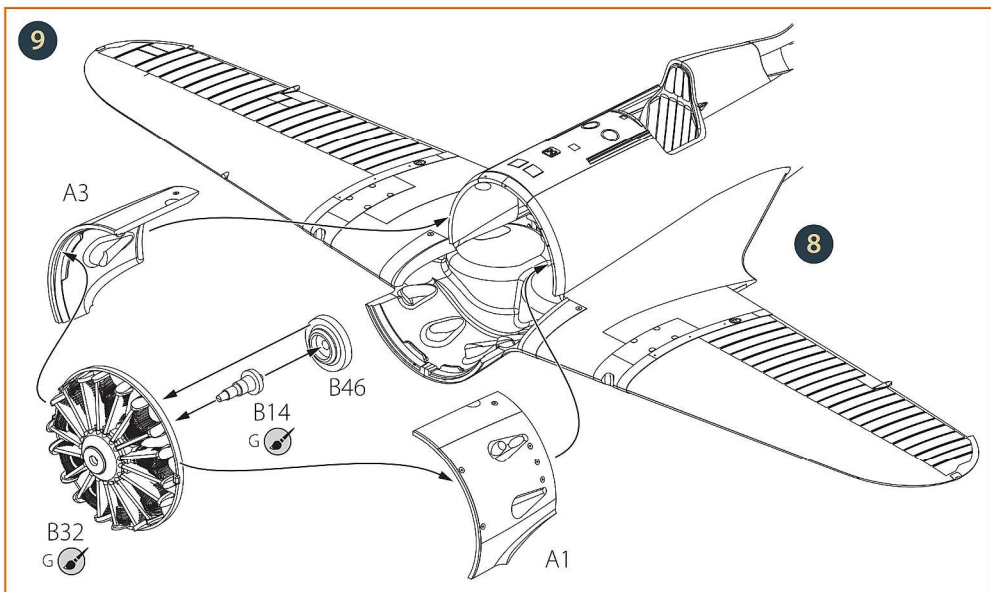

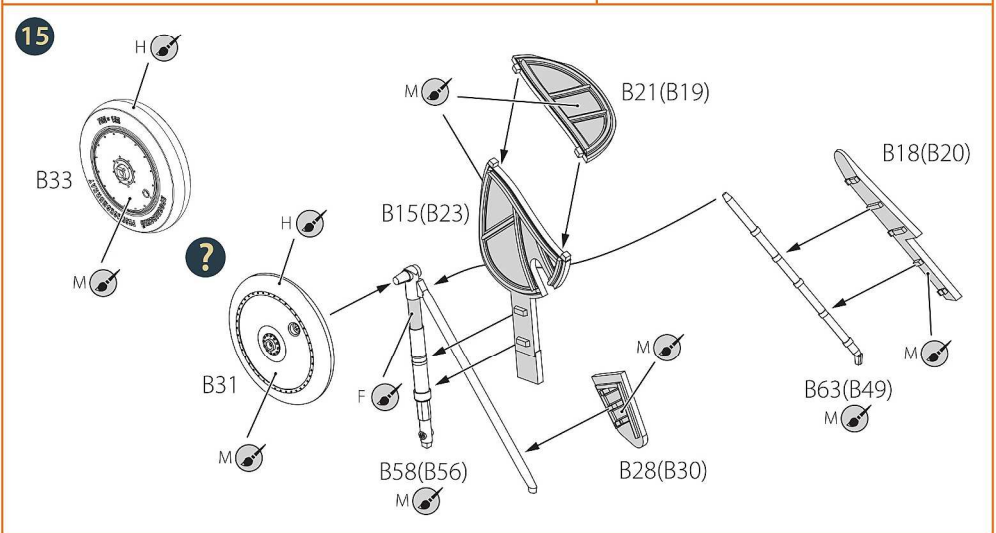
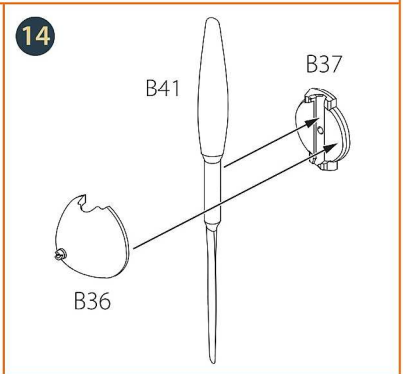
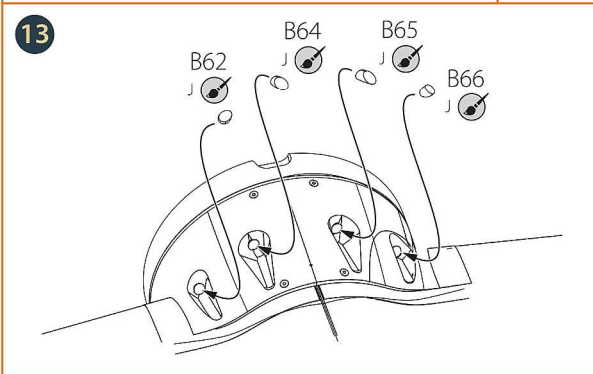
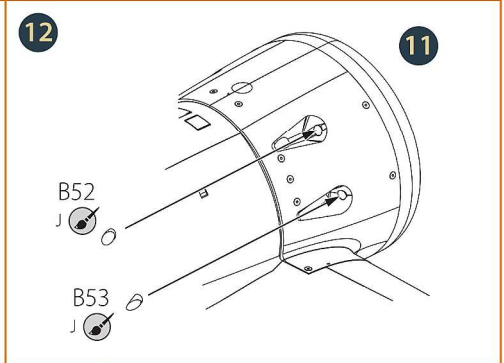
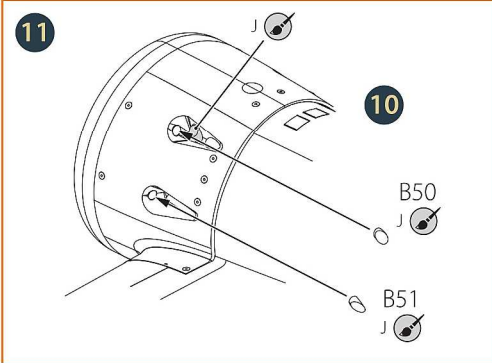

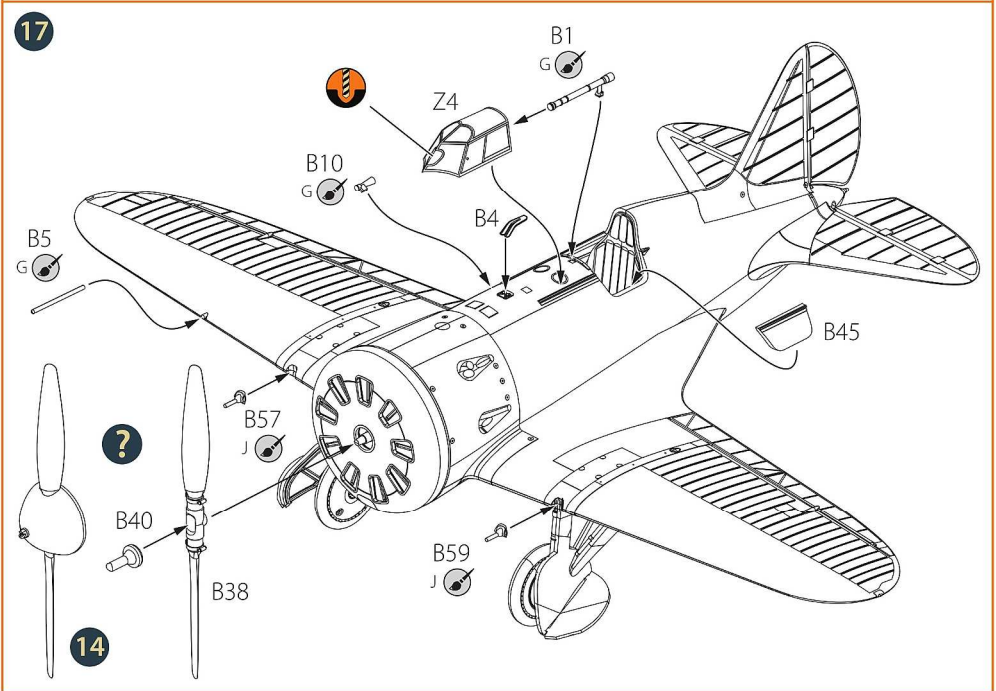
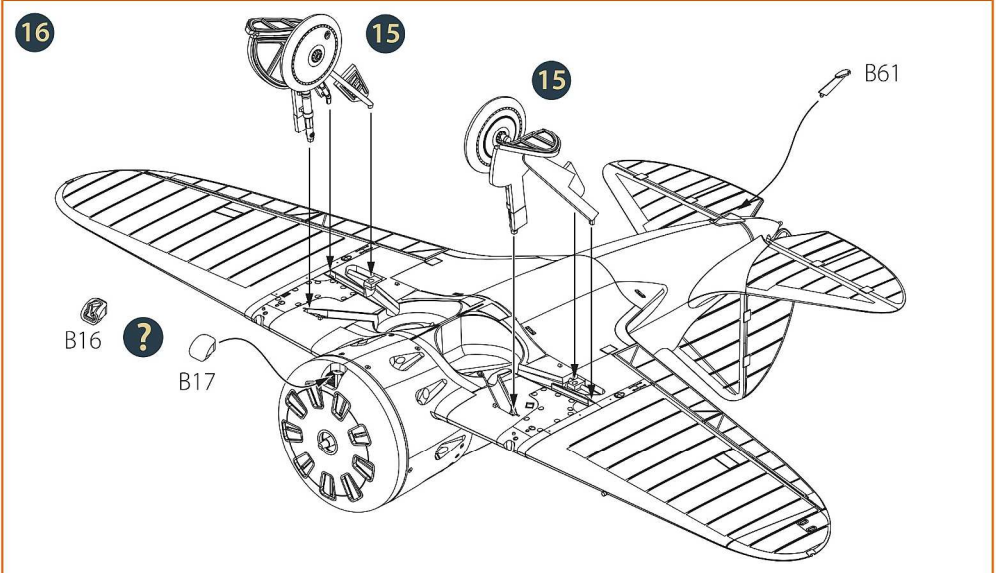



A.MIG-0080
AMT-4 GREEN

A.MIG-0046
AMT-6 BLACK

A.MIG-0224
SKY LINE BLUE

A.MIG-122
BONE

A.MIG-0191
POLISHED STEEL

A.MIG-0049
RED

A.MIG-0050
WHITE

- ① I-16 type 5. 21st Air Group, 1 aero. (1 Escuadrilla de Mosca). Aircraft of the Hero of the Soviet Union Senior Lieutenant Vladimir Bocharov. Madrid, 11/13/1936.

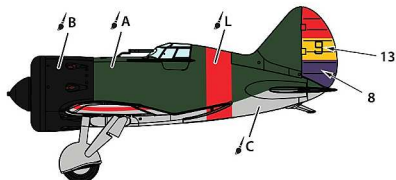
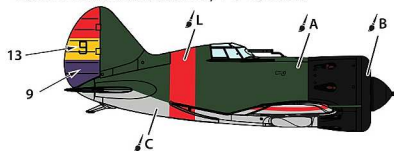

- ② I-16 type 5. Alown by pilot Sergey Kuznetsov, Carreno airfield. Possibly 1 air squadron (1 Escuadrilla de Mosca), October 1937.

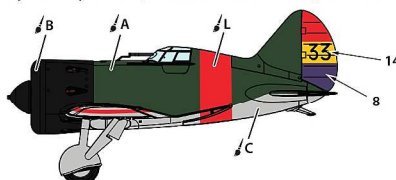
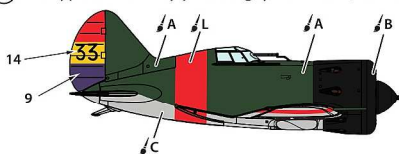

- ③ I-16 type 5. The plane of the Soviet pilots defending the port of unloading Cartagena, San Javier, 1936.

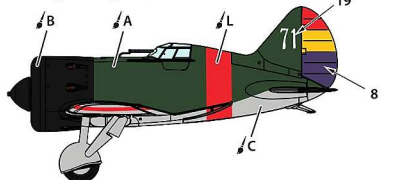
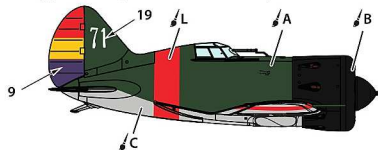

- ④ I-16 type 5. Torrijos Airfield. This aircraft was shot down during the Battle of Brunete Baitenente Tocci by Fiat CR.32 in July 1937.

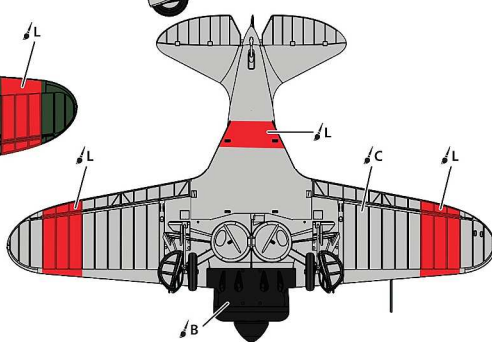
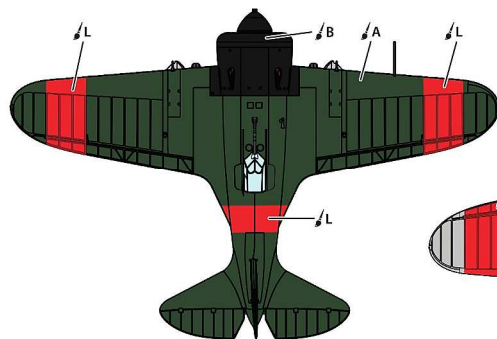
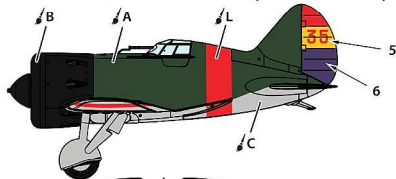
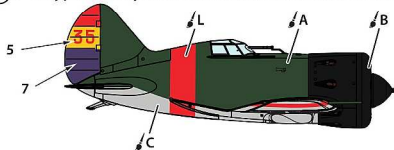



A.MIG-0080
AMT-4 GREEN



A.MIG-0046
AMT-6 BLACK



A.MIG-0224
SKY LINE BLUE



A.MIG-122
BONE



A.MIG-0191
POLISHED STEEL



A.MIG-0049
RED



A.MIG-0050
WHITE

⑤ I-16 type 5. 21 Air Group, 4 Air Squadron (4 Escuadrilla de Mosca), North of Spain, 1937-1938.

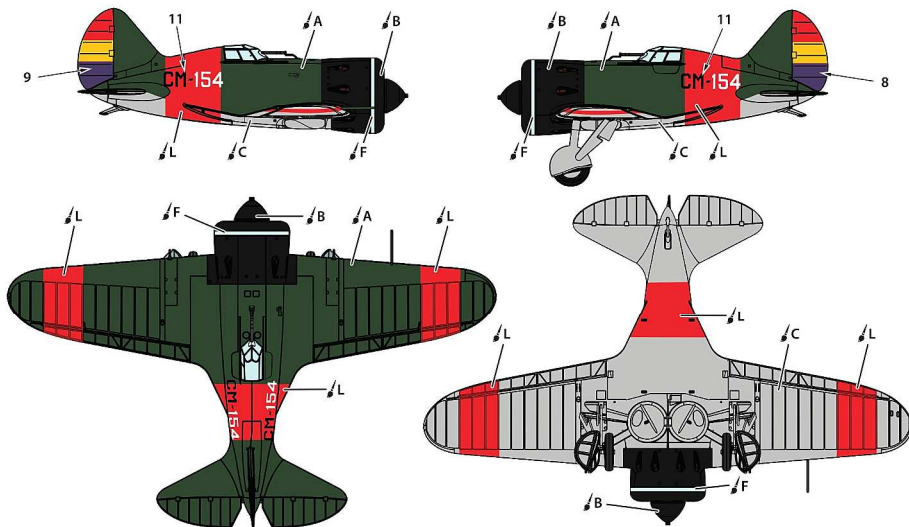

⑥ I-16 type 5. 21 Air Group, 4 Air Squadron (4 Escuadrilla de Mosca), 1937. Flown by pilots Sergeant Pedro Rueda and Jaime Perez Chulvi.

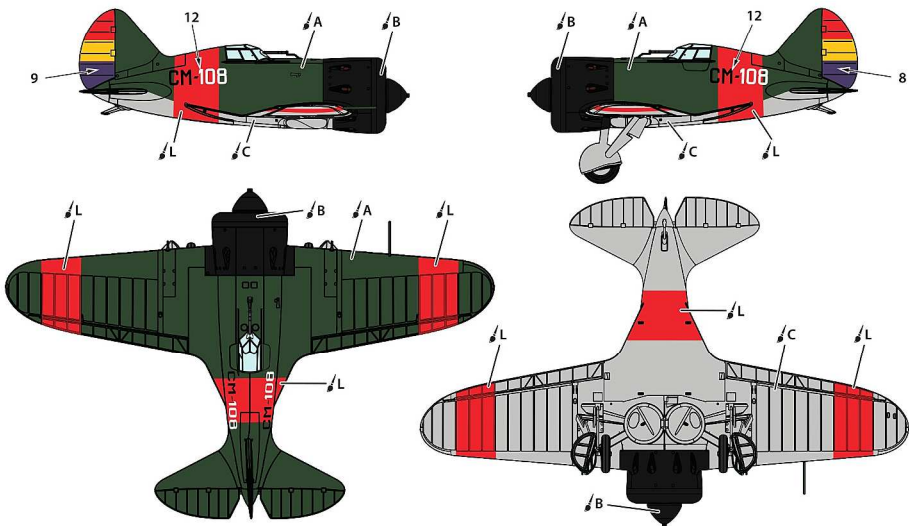



A.MIG-0080
AMT-4 GREEN



A.MIG-0046
AMT-6 BLACK



A.MIG-0224
SKY LINE BLUE



A.MIG-122
BONE



A.MIG-0191
POLISHED STEEL



A.MIG-0049
RED



A.MIG-0050
WHITE

⑦ I-16 type 5. 21 Air Group, 4 Air Squadron (4 Escuadrilla de Mosca), 1937-1938. Flown by pilots Morales and Zarauza.

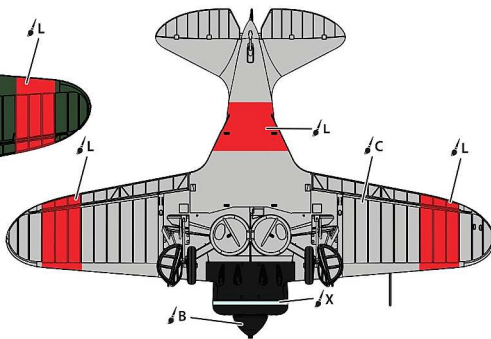
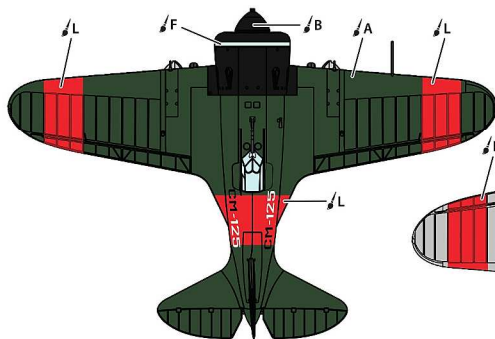
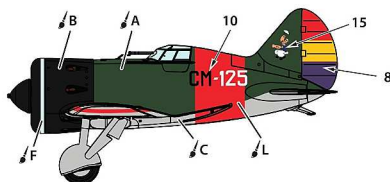
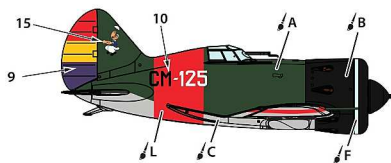

⑧ I-16 type 5. Nationalist trophy, Cuatro Vientos airfield (de Cuatro Vientos.) According to other sources airfield - Seville-Tablada. March 1938.

