

32.

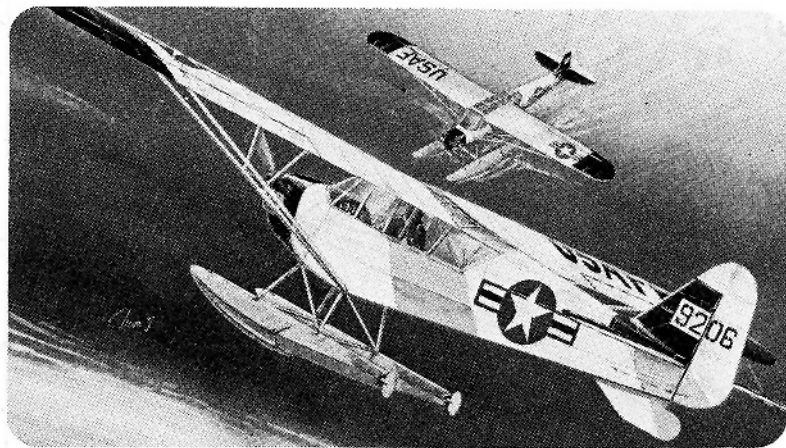

1:72

PLASTIKOVÁ STAVEBNICE MODELU LETADLA  
MODEL KIT



1992

PIPER L-4 H

The L-4H aeroplane, the prototype of which was first flown in 1930, entered permanently into aviation history and gained a significant position among the far more known aeroplanes of the pre-war and war era. 8 673 aeroplanes of all versions produced are evidencing design adaptability of this aeroplane which was originally designed as a sporting and touring aeroplane. In course of the II. World war it was serving courier, observation, liaison, ambulance and other purposes required by the U. S. Air Force and Navy. The aeroplane was reliably serving on all the World War II fronts from Europe through Africa to the Pacific battlefields. Fitted with skis it was operated on snow and fitted with floats in areas abounding with water surfaces. Popularity and reliability earned the aeroplane a nickname „Flying Jeep.“ The motorless version served as a glider for training and transport of smaller loads.

The Pipers returned to their original designation, i. e. to sporting flying. These aeroplanes were operated perhaps in all European states 246 of them were reliably serving in Czechoslovakia with aeroclubs under the designation C-8 and designated K-68 with the Air Force.

### Technical Description

The Piper L-4H aeroplane is a single engine, two-seater, strut highwing monoplane of mixed construction covered with fabric and supplemental metal panels.

### Fuselage

structure consists of welded steel tubes covered with fabric, wooden cockpit floor and a two piece duralumin engine cowling. The fuel tank and engine are attached to a metal fire-wale in the front fuselage section. The fuselage is supported on a classical two wheel landing gear with wheel dimensions 450x220 mm and a track of 1,83 m. Tail wheel attached to the last fuselage bulkhead has a dimension of 115x60 mm.

Two seat cockpit is equipped with a fabric covered tube structure front seat, whereas the rear seat is formed by a plane panel with a fabric strap backrest. The cockpit is equipped with basic instruments installed in front of the front seat and the aeroplane may be controlled from both pilot seats.

### The Wing

is a double-spar mixed construction with duralumin ribs of NASA 23012 airfoil. It is a rectangular wing covered with fabric and carrying ailerons. The wing is supported with V-shaped struts attached to the rear landing gear attachment joint on the fuselage.

### Fin Unit and Rudder

is of a steel tube construction with three duralumin ribs. There is a smooth transition from fin unit into rudder, which has a plane panel profile. The whole assembly is covered with fabric, the control surface being aerodynamically balanced.

### Horizontal Tail Unit and Elevator

has a plane panel shape, and a construction of fabric covered steel tubes. The horizontal tail unit is supported by struts attached to its lower surface and to the fuselage.

### Airborne Equipment

was supplied in accordance with the intended aeroplane use. As a rule the military versions were equipped with a radio communication set, its antenna being attached on the cockpit. The antenna attachment differed with type of the radio communication set. Both whip and wire antennas were used.

### Engine, Oil and Fuel System

The Continental A-65-8 four cylinder, four stroke, air-cooled boxer engine, rated at 48 kW was installed as a rule in military versions. The engine was fitted with a two blade wooden propeller. A filter and radiator are connected to the oil tank having a capacity of 7 dm<sup>3</sup>.

A fuel tank having a capacity of 43 dm<sup>3</sup> was fitted with a fuel quantity indicator displaying the quantity of fuel by means of extending a rod in the pilot's field of vision up to a height of 28 cm.

The Praga-D four cylinder four stroke, air-cooled boxer engine, rated at 55 kW was installed in aeroplanes operated after the World War II in Czechoslovakia and Poland.

### Colouring

The Piper L-4H aeroplanes were flying with most varied colouring. Military versions of the U. S. Army and U. S. Air Force were painted as a rule in olive-green on the upper side and in light grey on the lower side. The ensigns were displayed on the port wing upper surface and on the starboard wing lower surface, as well as on both sides of the fuselage. At the time of invasion into Normandy the Pipers had invasion Stripes painted on the wings and on the fuselage. A four to six digit tail number was marked in yellow on the fin unit.

The C-8 aeroplanes were flying in Czechoslovakia with most varied colouring in aeroclubs, whereas those flying in the Air Force had a green (khaki) coating on the upper and light blue coating on the lower surfaces. The ensign was displayed on the upper and lower wing skin and the No. 26 aeroplane had the ensign located on the rudder.

An all silver Piper L-4h aeroplane is displayed in the L+K Exposition in Prague-Kbely with a black number 10 on the fuselage.

### Technical data:

Wing span: 10,740 m cca (35 ft. 2 7/8in.)  
Length: 6,710 m cca (22 ft. 1/8in.)  
Height: 2,000 m cca (6 ft. 6 6/8in.)  
Max. speed: 137 km/hod. (85,14 m.p.h.)  
Relentless: 2,5 hod.

### Technical data

#### More Detailed Information

Archives of the L+K Exposition, Prague-Kbely  
Archives of a private enterprise KIT PRO, Ltd. Prostějov  
TBU 130 - Samolot wielozadaniowy Piper L-4 CUB  
Air Plane II. War, Vol. IV

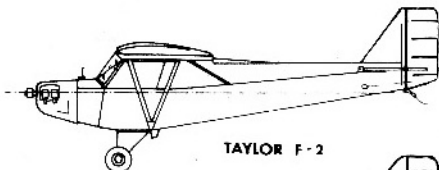

TAYLOR F-2

**Drawings  
no scale 1:72**

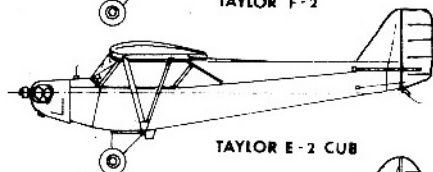

TAYLOR E-2 CUB

**Kresby nejsou  
v měřítku 1:72**

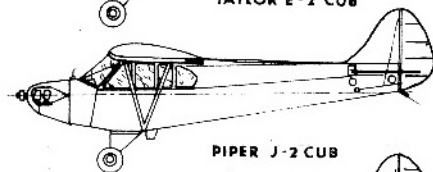

PIPER J-2 CUB

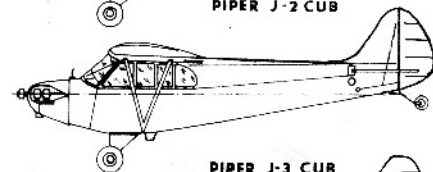

PIPER J-3 CUB

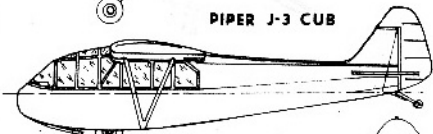

PIPER TG-8

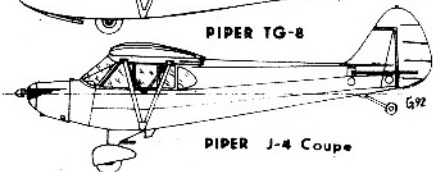

PIPER J-4 Coupe

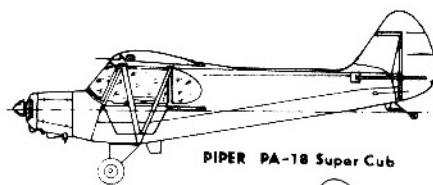

PIPER PA-18 Super Cub

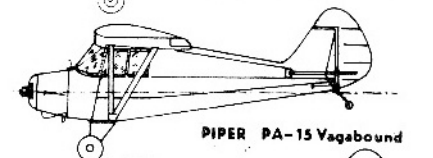

PIPER PA-15 Vagabound

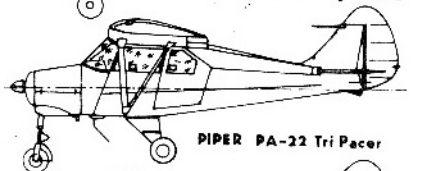

PIPER PA-22 Tri Pacer

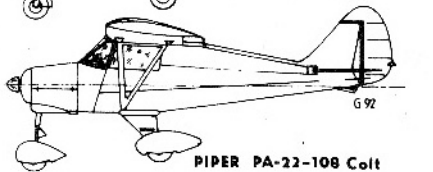

PIPER PA-22-108 Colt

**KOVOZÁVODY  
za Dolní ul.21  
PROSTĚJOV  
ČSFR**

# STAVEBNÍ POSTUP

# ASSEMBLY INSTRUCTION

# BAUANLEITUNG

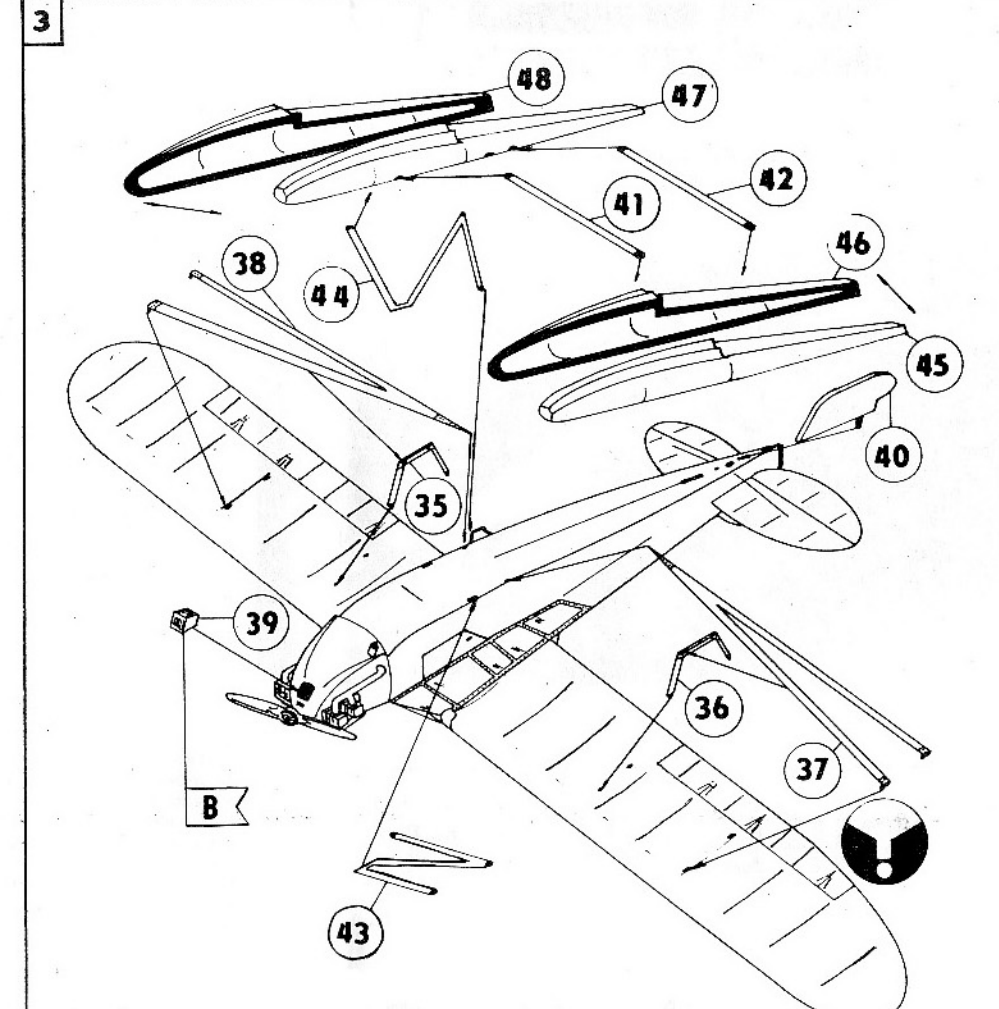
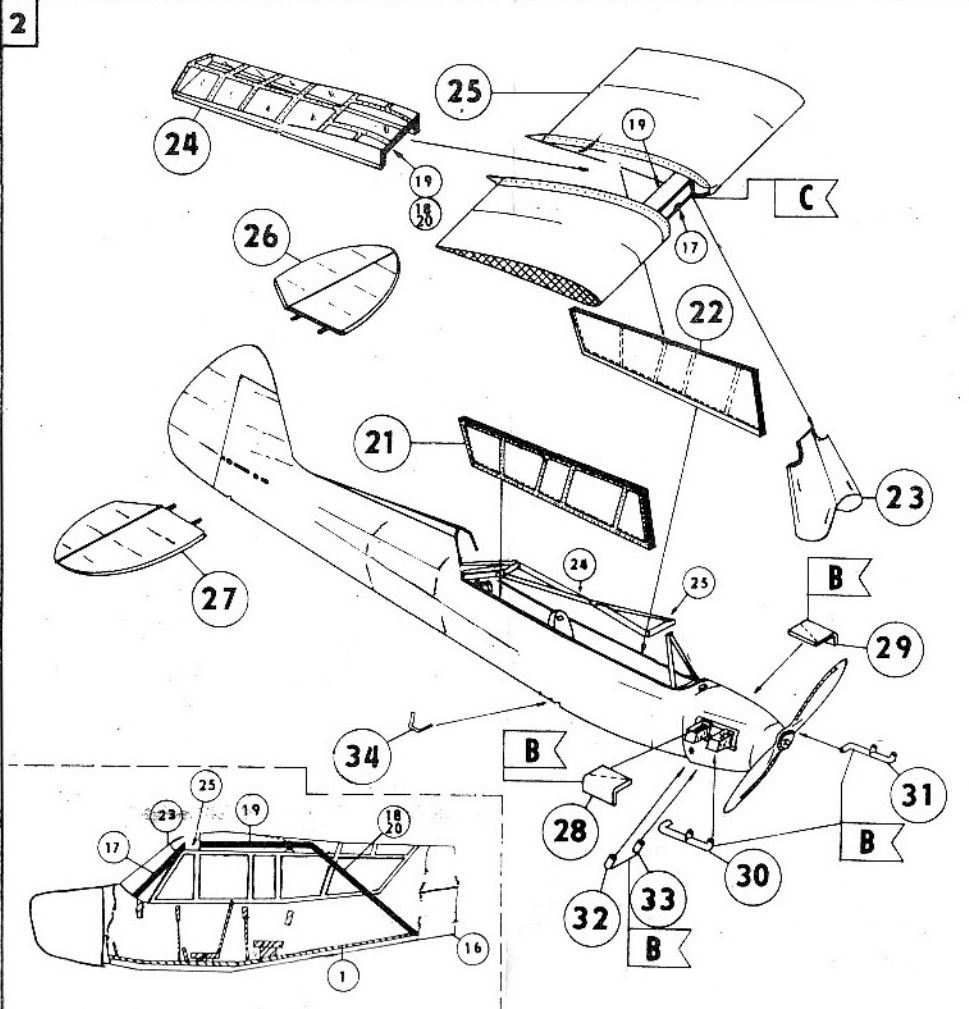
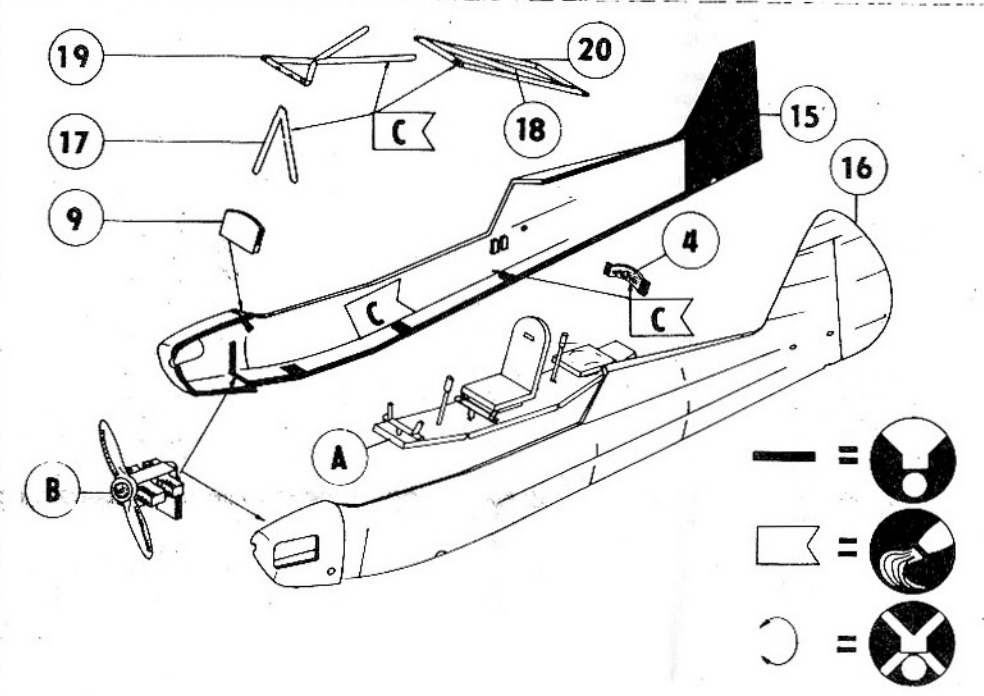
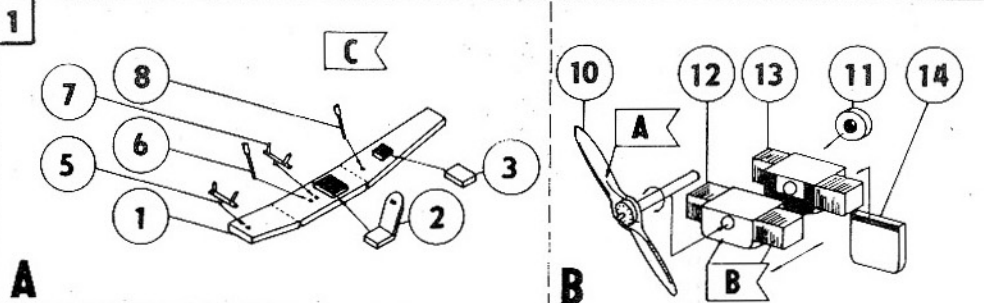

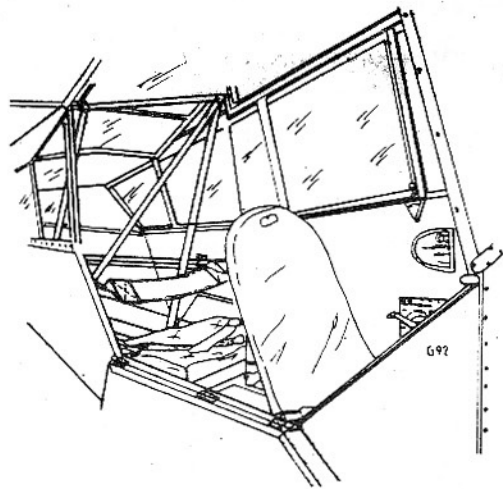

G92

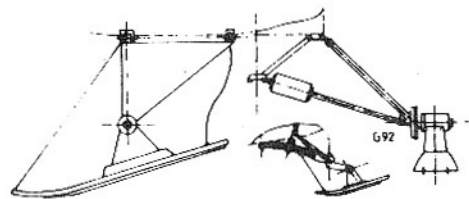

G92

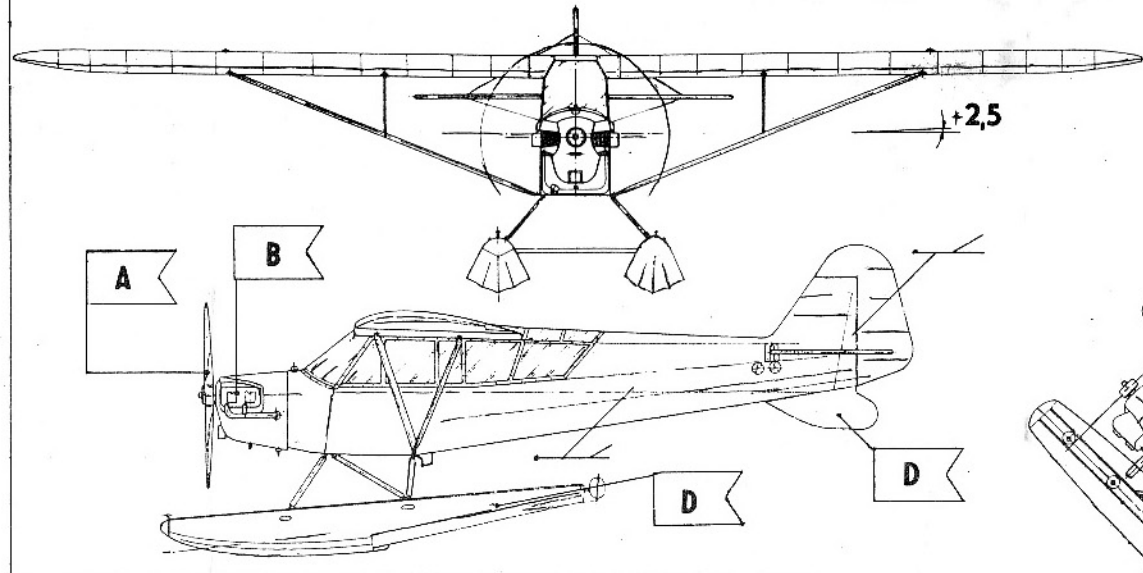
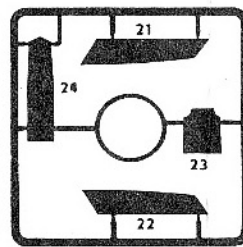
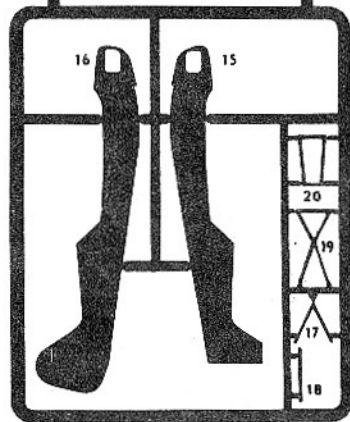
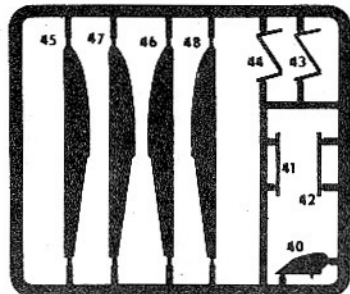
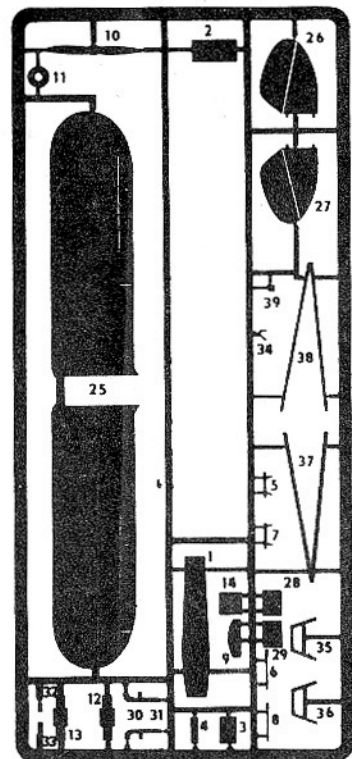

+2,5

1:72

- |          |                        |   |
|----------|------------------------|---|
| <b>A</b> | HNĚDA<br>BROWN         | H +29<br>R =87                                    |
| <b>B</b> | ČERNÁ<br>BLACK         | H +21<br>R = 7                                    |
| <b>C</b> | ŠEDÁ<br>GREY           | H +64<br>R +75                                    |
| <b>D</b> | ALUMINIUM<br>ALUMINIUM | H +56<br>R +99                                    |
|          | OBTISK<br>DECAL        | FS+30 117<br>FS+17 038<br>FS+26 373<br>FS+ 17 178 |

H-HUMBROL  
R-REVELL  
FS-FEDERAL STANDARD

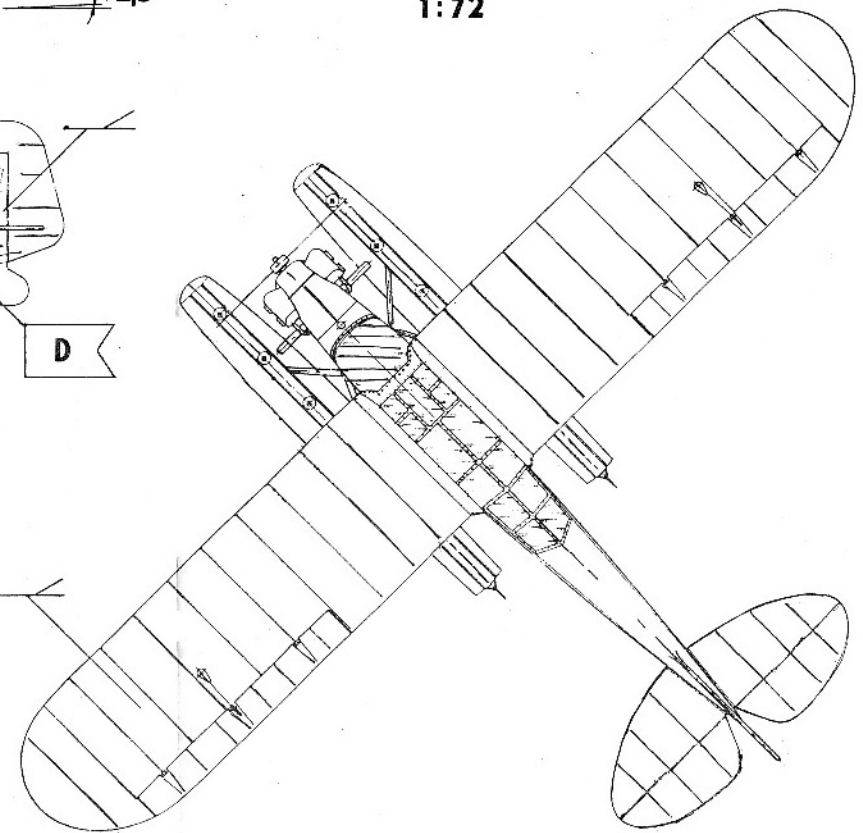

KOVOZÁVODY  
za Dolní ul.21  
PROSTĚJOV  
ČSFR



# L-4H PIPER CUB

G92

# PIPER L-4H

kamufláž a označení letounu



Nº 32

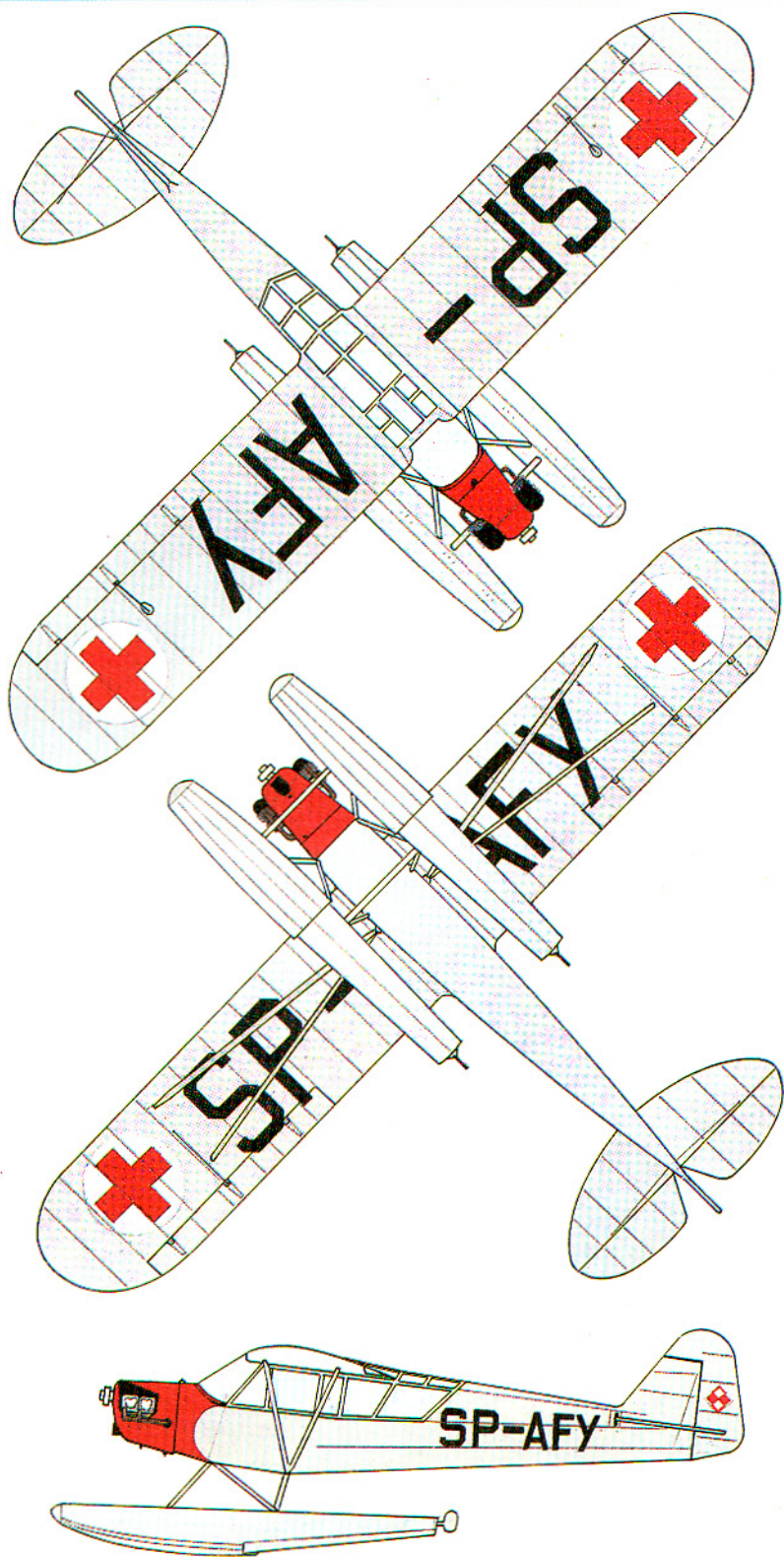

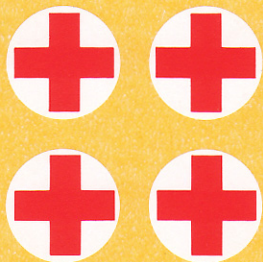
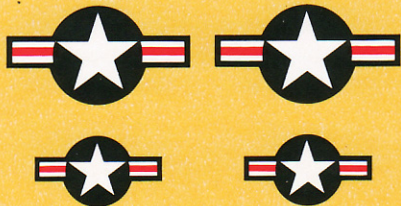

**USAF**  
**USAF**

9206



9206

SP-AFY

SP-AFY

**SP-AFY**  
**SP-AFY**



**/// PROPACTEAM**

**PIPER L-4 H**