



EXPERT



GLOSTER E28/39 PIONEER

1:72
model # 72001



scale model kit

SPAN: 123 mm



LENGTH: 107 mm



NUMBER OF PARTS: 149 pcs

- stages of assembly
- optional
- variants of assembly
- glue by super glue
- part number
- do not glue
- separate details
- make a hole
- apply decals
- detach with knife
- apply the adhesive mask
- paint
- bend
- repeat the operation N times

Role	Experimental prototype
National origin	United Kingdom
Manufacturer	Gloster Aircraft Company
Designer	George Carter
First flight	15 May 1941
Status	Retired
Primary user	Royal Aircraft Establishment (RAE)
Number built	2 prototypes

The Gloster E.28/39, (also referred to as the Gloster Whittle, Gloster Pioneer, or Gloster G.40) was the first British jet-engined aircraft and first flew in 1941. It was the third jet to fly after the German Heinkel He 178 (1939) and the Italian Caproni Campini N.1 motorjet (1940).

The E.28/39 was the product of a specification which had been issued by the Air Ministry for a suitable aircraft to test the novel jet propulsion designs that Frank Whittle had been developing during the 1930s. Gloster and the company's chief designer, George Carter, worked with Whittle to develop an otherwise conventional aircraft fitted with a Power Jets W.1 turbojet engine. Flying for the first time on 15 May 1941, a pair of E.28/39 aircraft were produced for the flight test programme. Following initial satisfactory reports, this aircraft continued to be flown to test increasingly refined engine designs and new aerodynamic features.

The E.28/39 contributed valuable initial experience with the new type of propulsion and led to the development of the Gloster Meteor, the first operational jet fighter to enter service with the Allies.

REQUIRED PAINTS

A HUMBROL 56 ALUMINIUM

B HUMBROL 29 DARK EARTH

C HUMBROL 116 DARK GREEN

D HUMBROL 106 OCEAN GREY

E HUMBROL 188 TRAINER YELLOW

F HUMBROL 70 DULL RED

G HUMBROL 27004 GUN METAL

H HUMBROL 33 BLACK

J HUMBROL 78 COCKPIT GREEN

K HUMBROL 62 LEATHER

L HUMBROL 11 SILVER

THIS MODEL IS PRODUCED FOR EXPERIENCED MODELERS OVER 14 YEARS

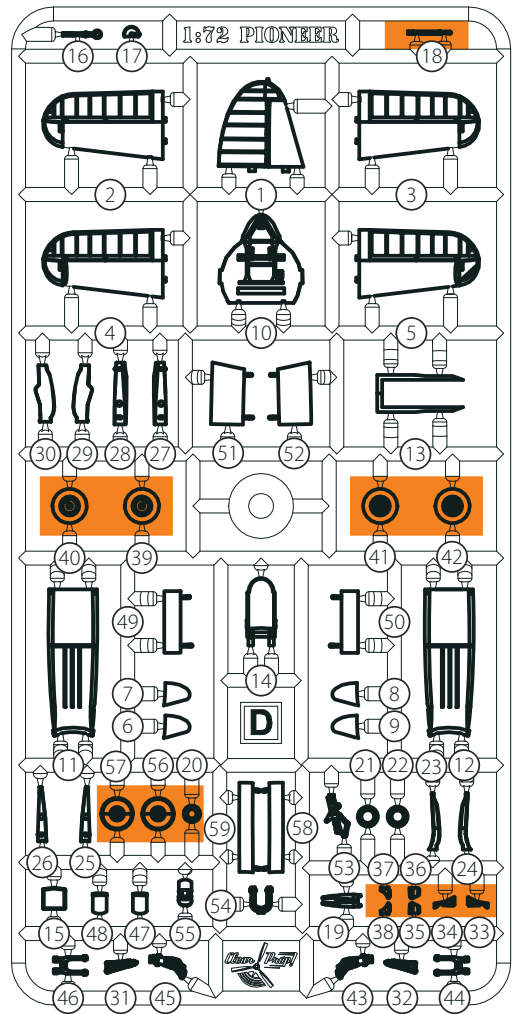
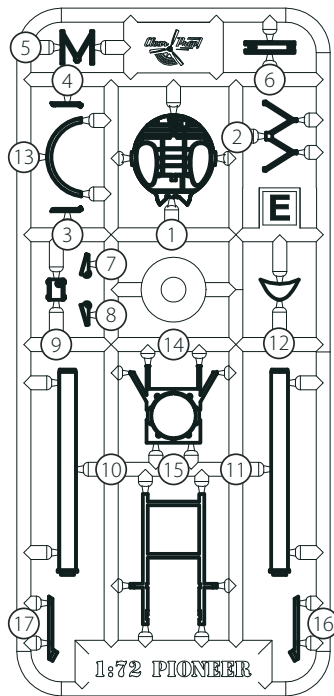
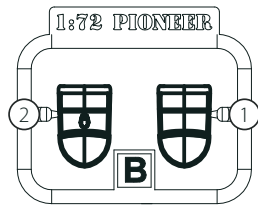
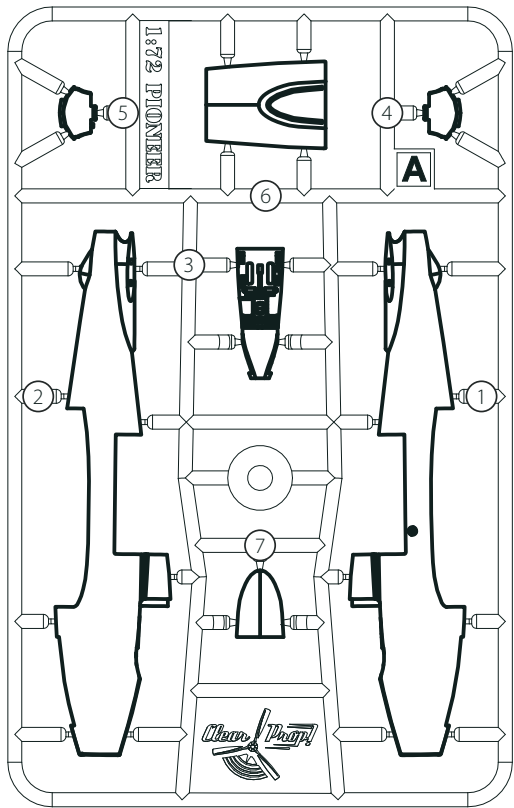

PHOTOETCHED PARTS

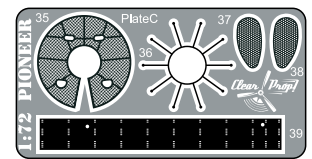
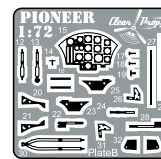
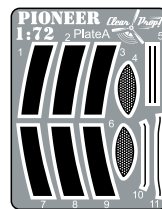

DECAL SHEET

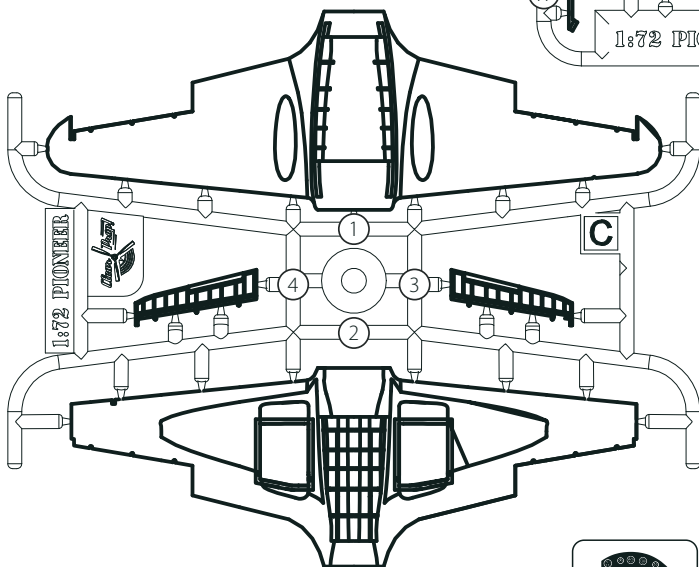
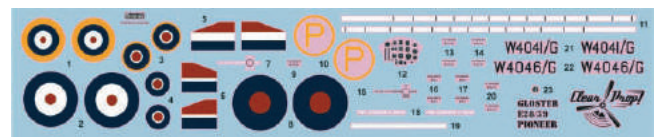

MASKS



CLEAR FILM

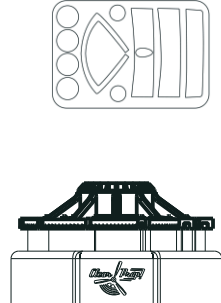

R1

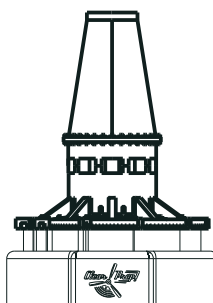

R2

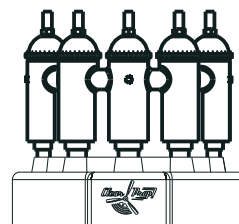

R3

BRASS PITOT TUBE



R4(10x)



R5



R6



Rw1



Rw2(2x)

Parts not for use

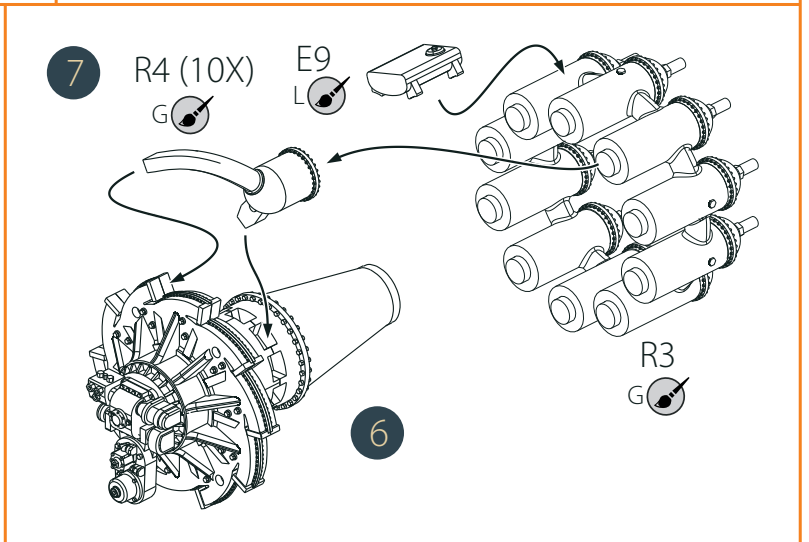
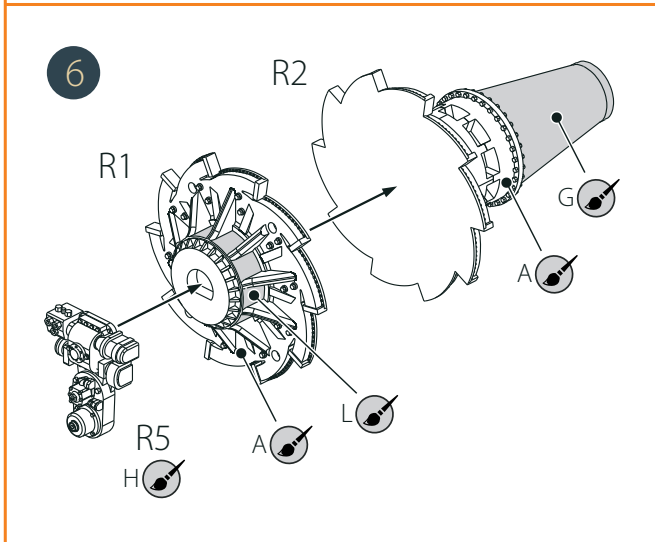
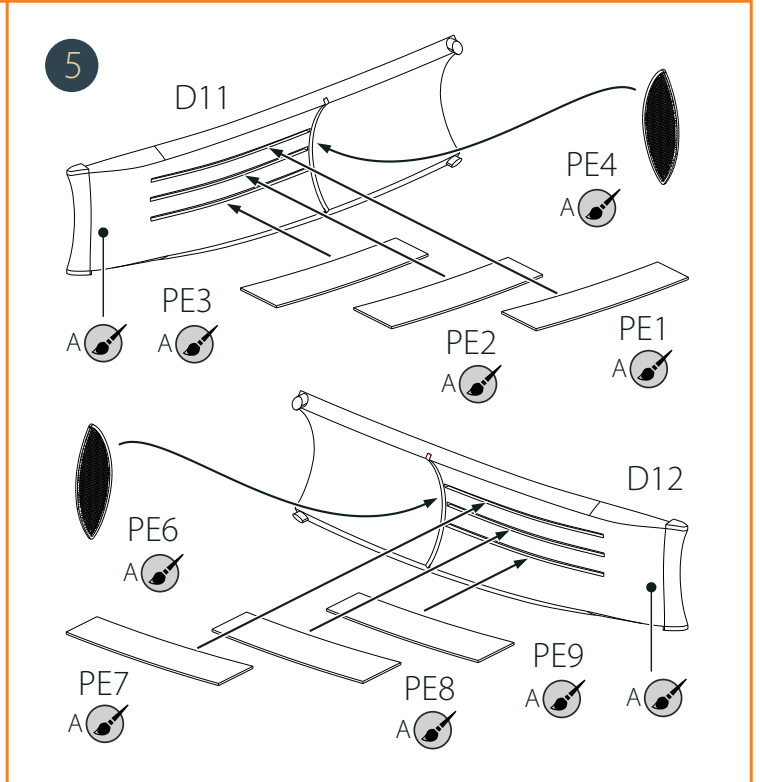
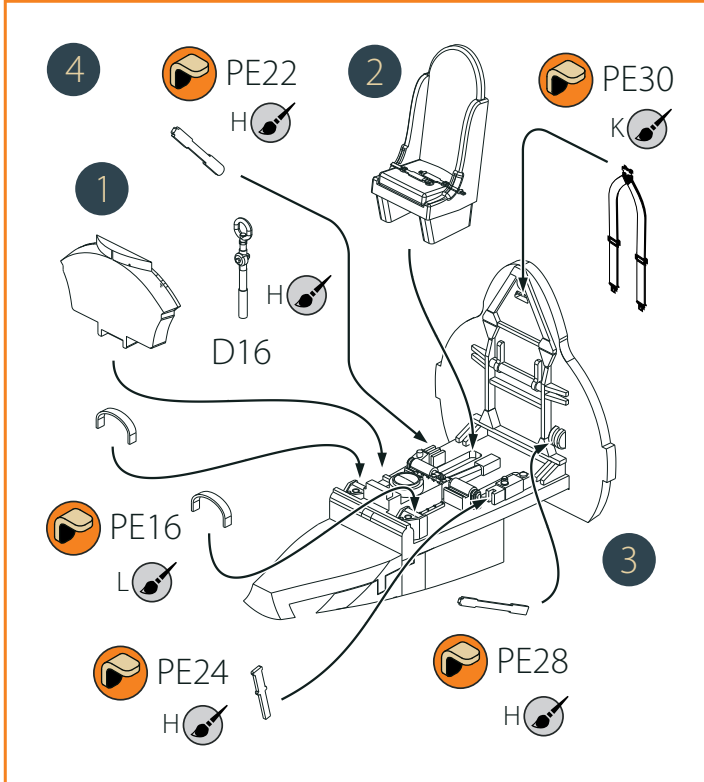
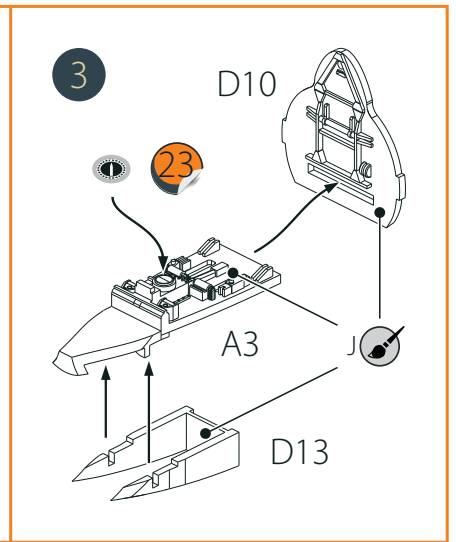
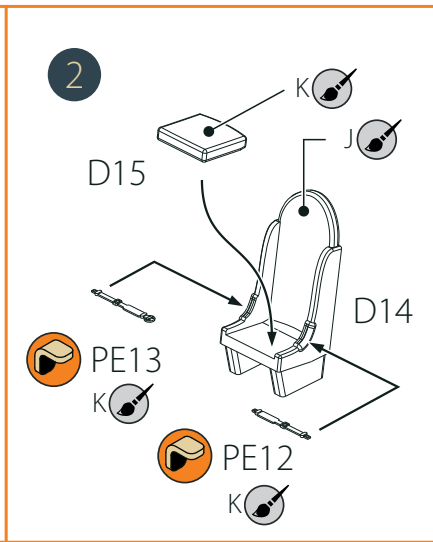
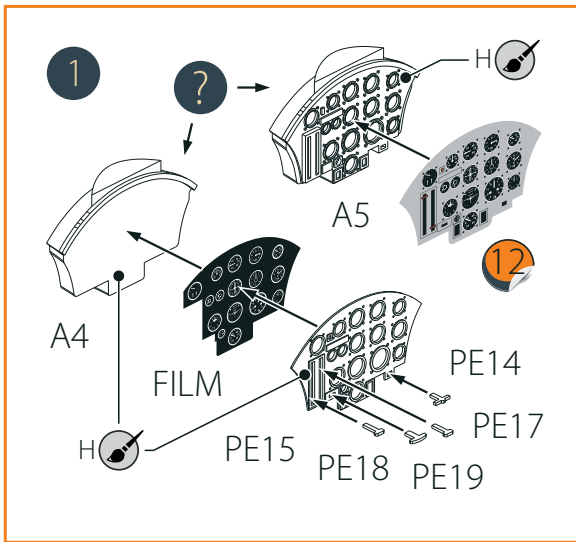

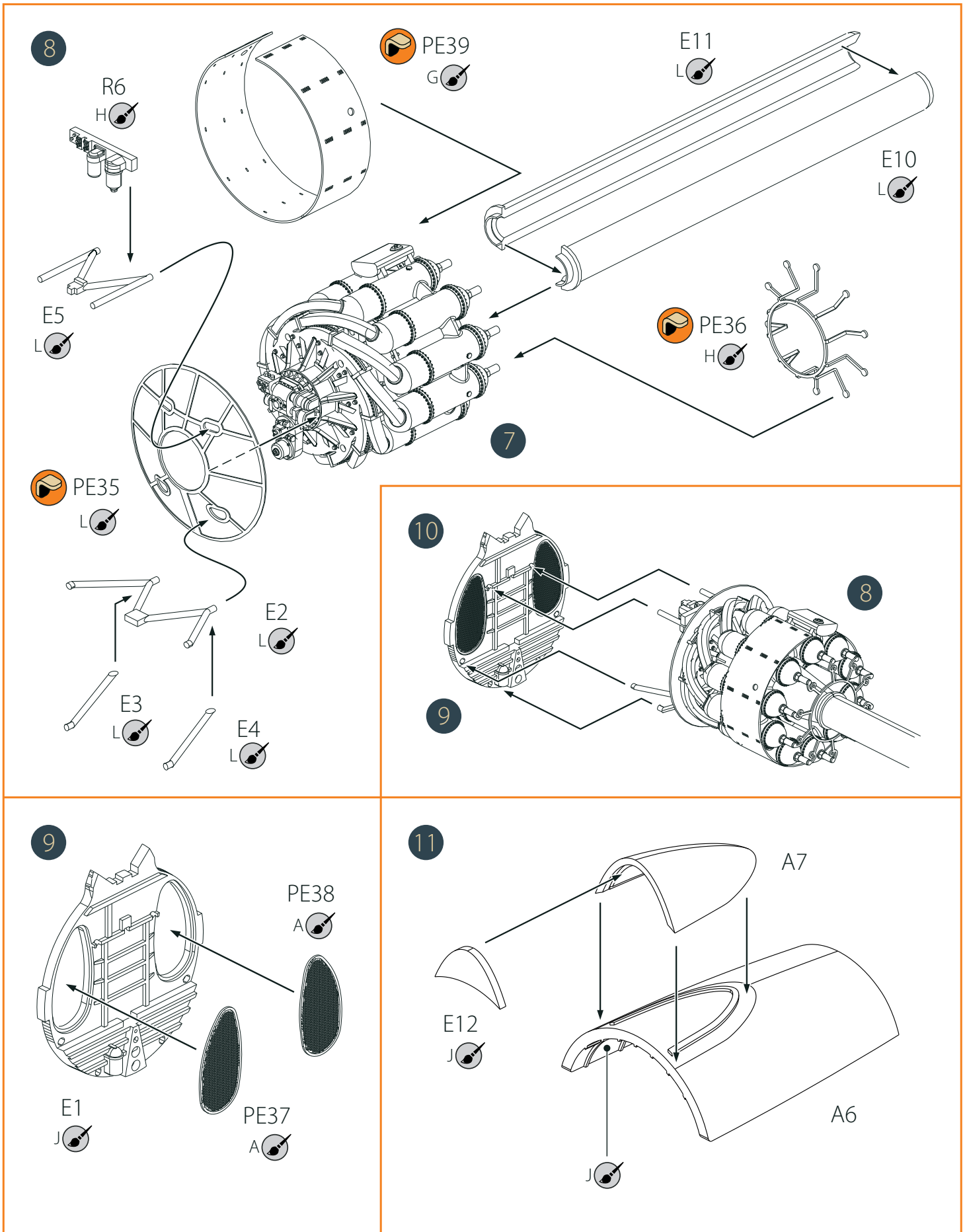

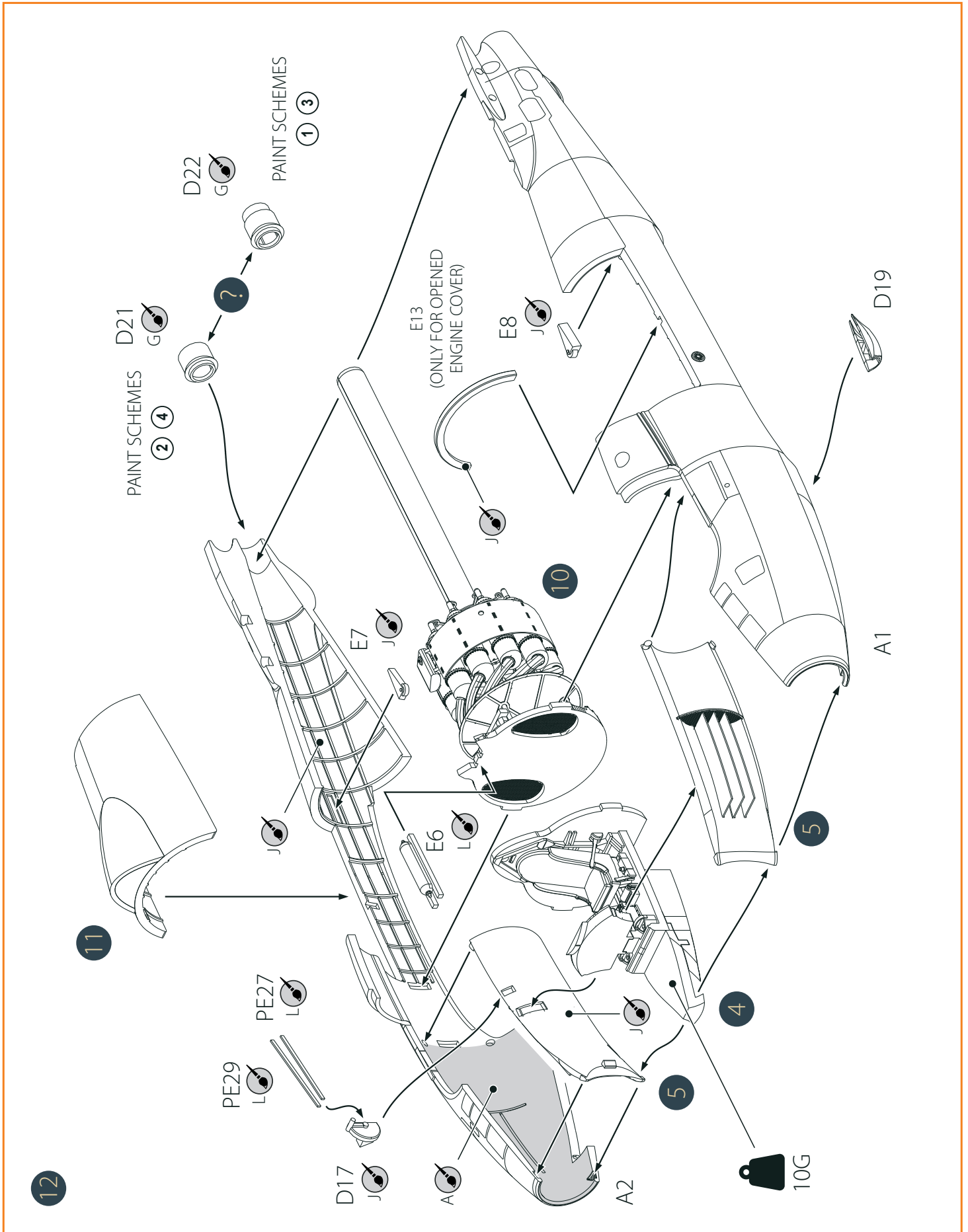

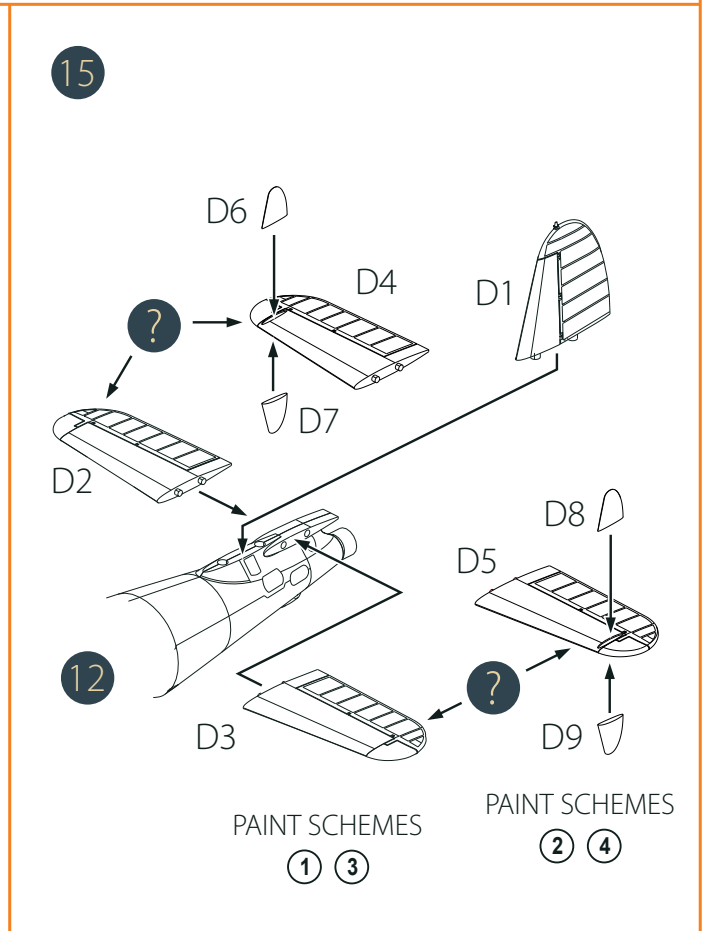
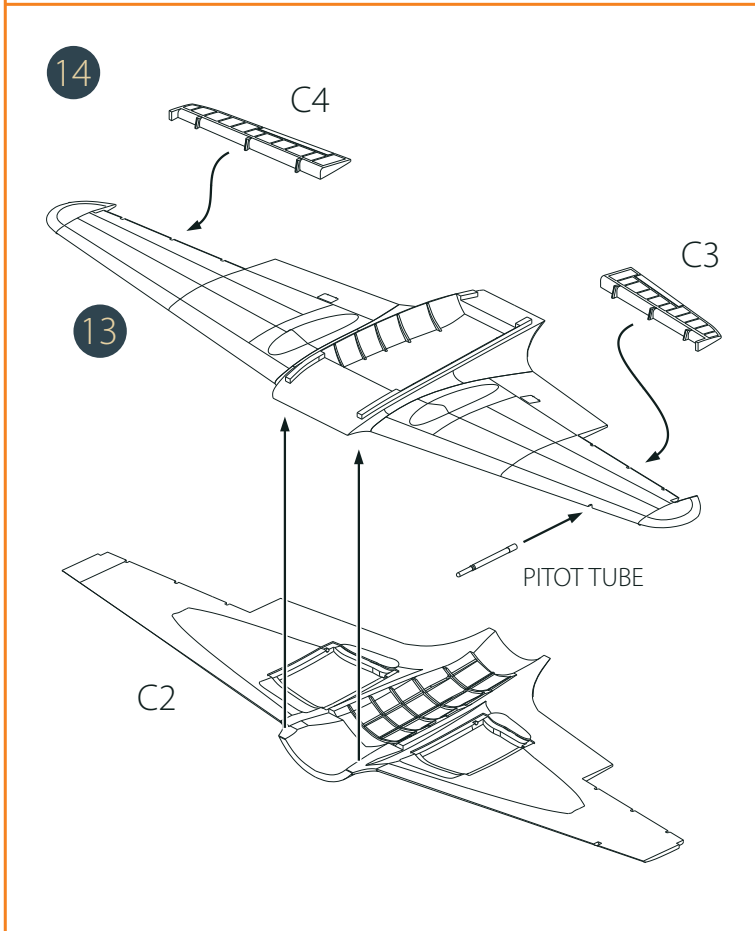
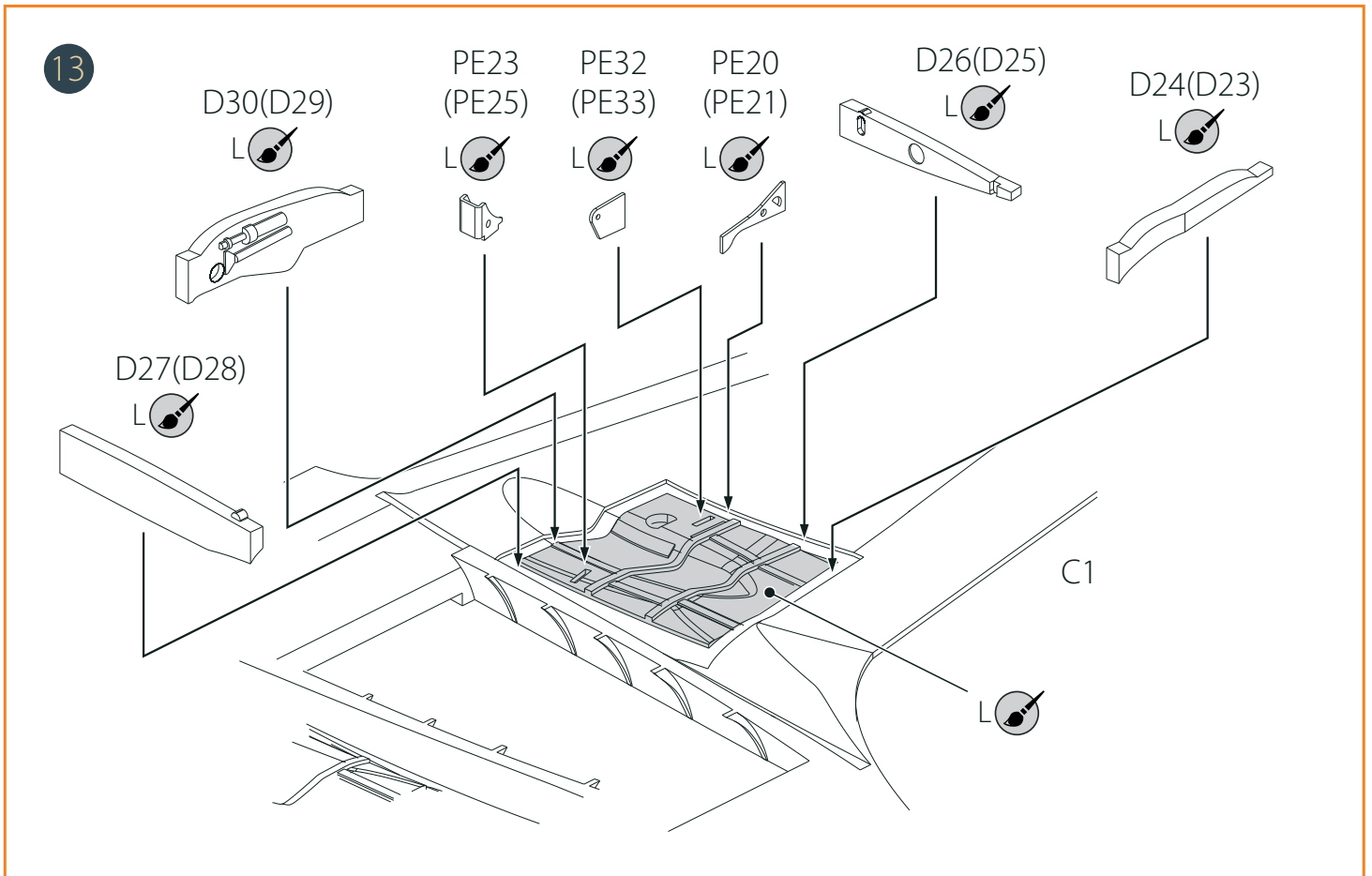

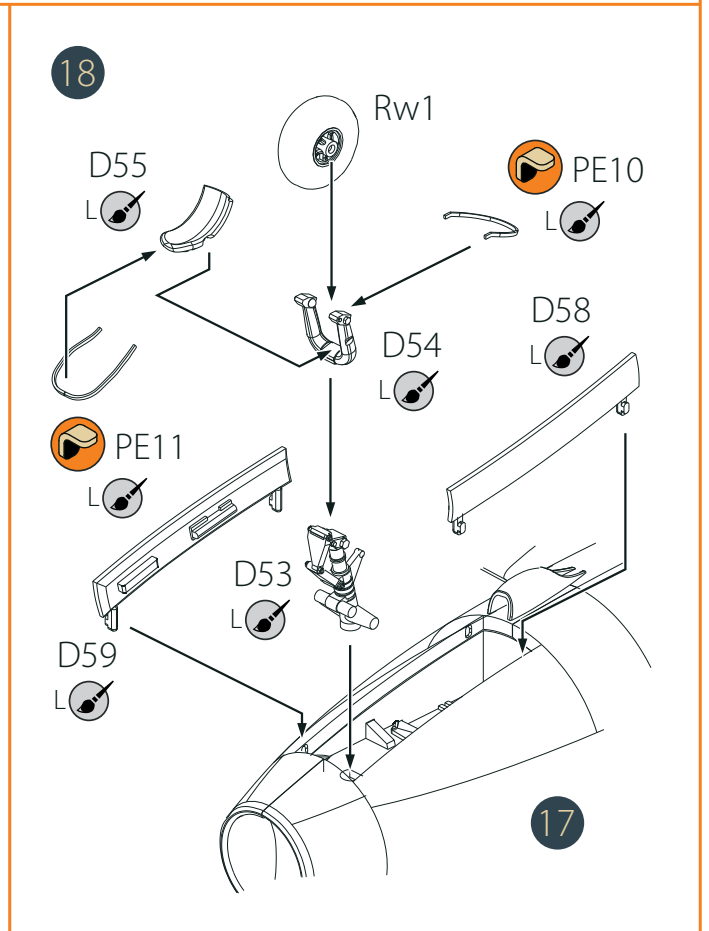
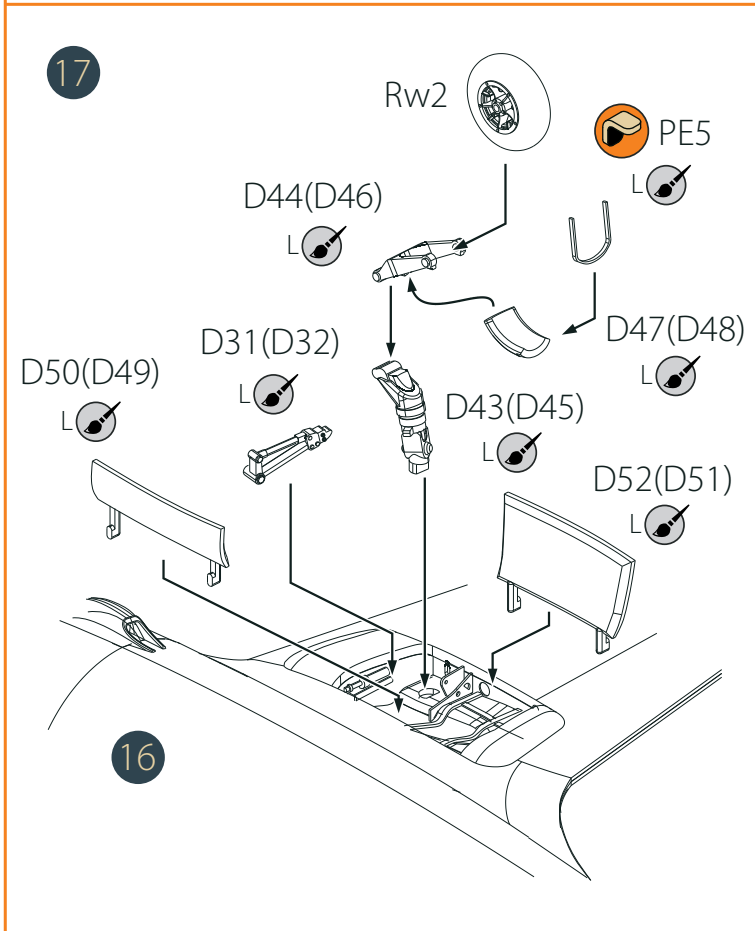
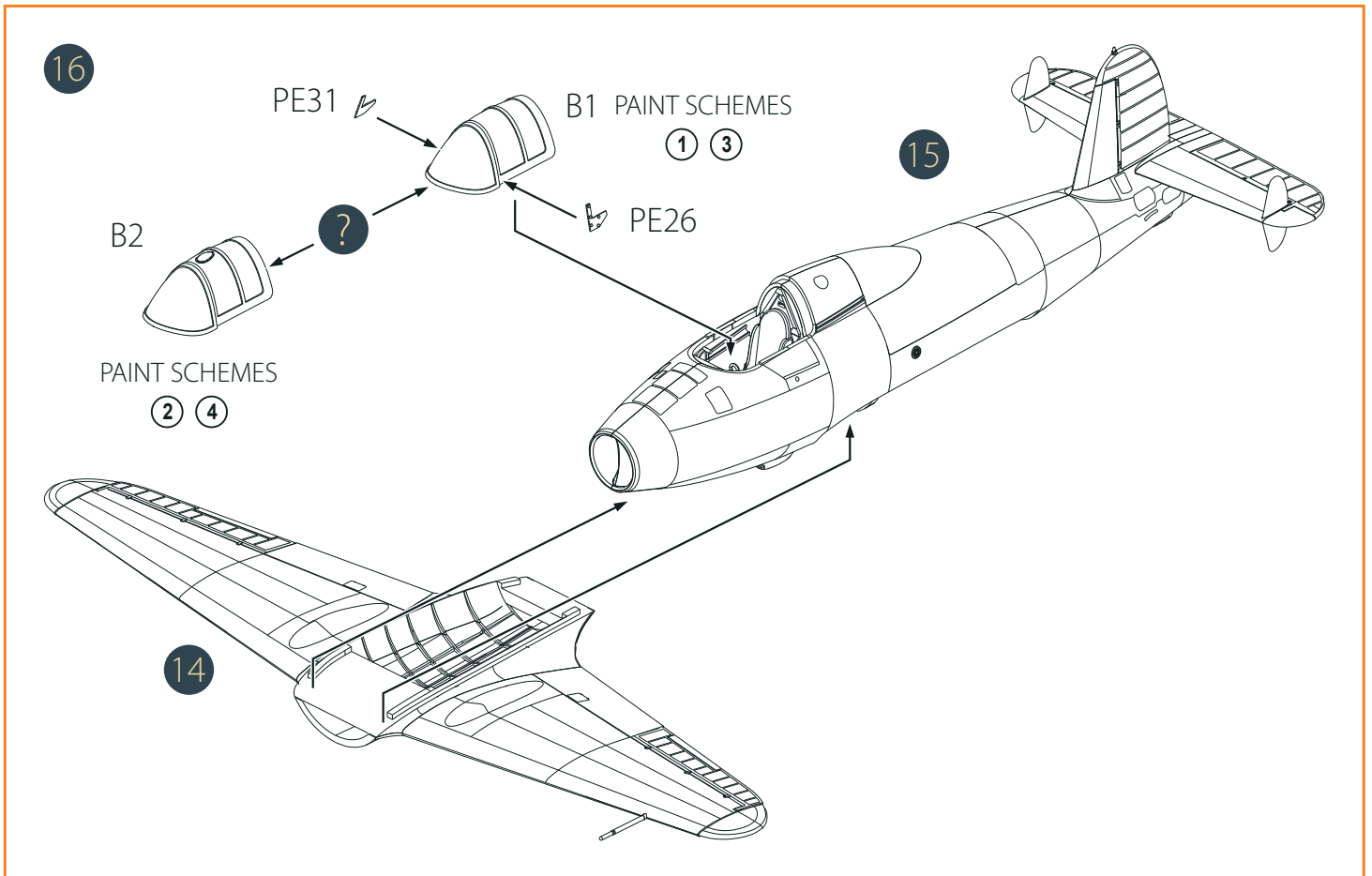

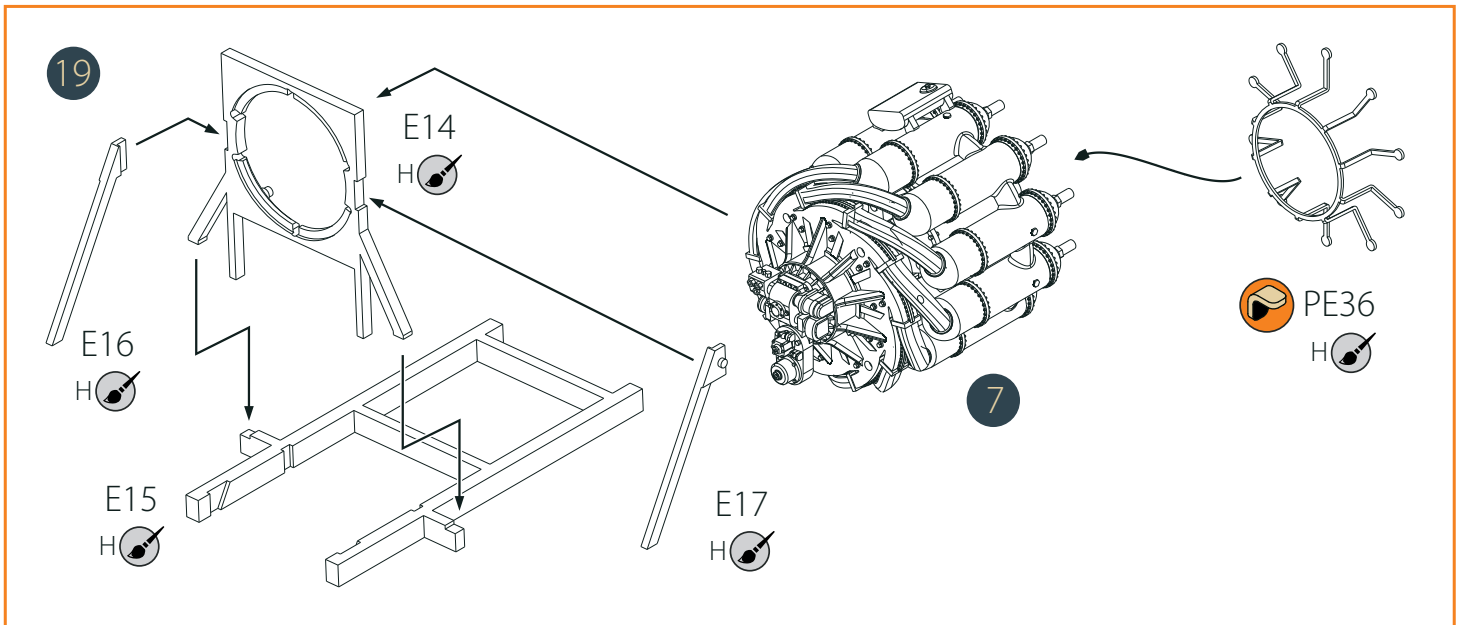

CORRECT VIEWS OF
LANDING GEARS
SCALE 1:1

NOSE LANDING GEAR:

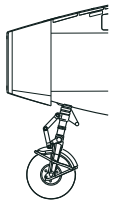

MAIN LANDING GEAR:

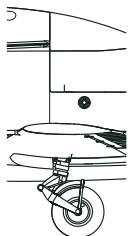

VARIANTS OF ASSEMBLY

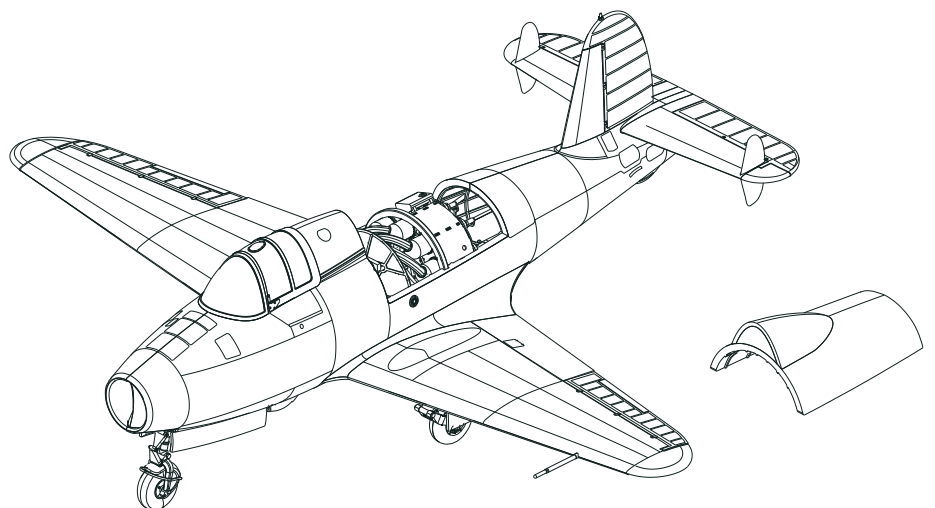
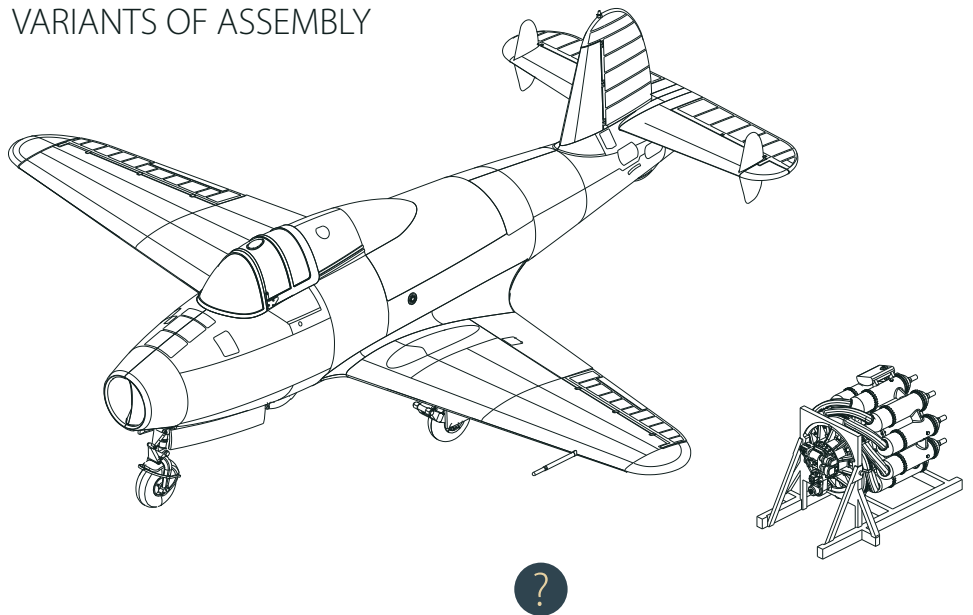



A
HUMBROL 56
ALUMINIUM



B
HUMBROL 29
DARK EARTH



C
HUMBROL 116
DARK GREEN



D
HUMBROL 106
OCEAN GREY



E
HUMBROL 188
TRAINER YELLOW



F
HUMBROL 70
DULL RED



G
HUMBROL 27004
GUN METAL



H
HUMBROL 33
BLACK

①

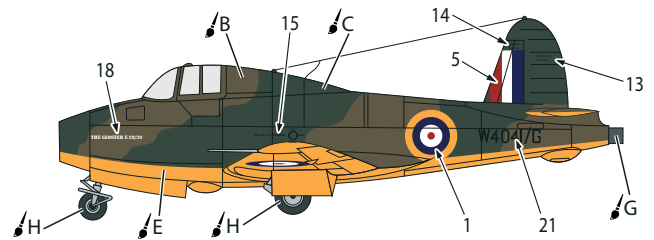
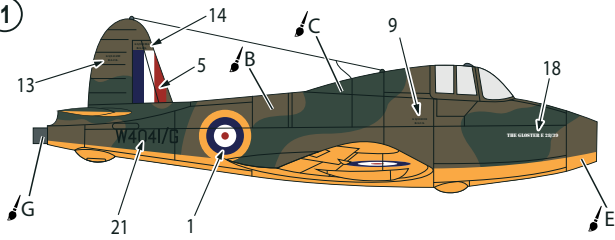

Gloster E28/39 W4041 at RAF Cranwell, May 1941

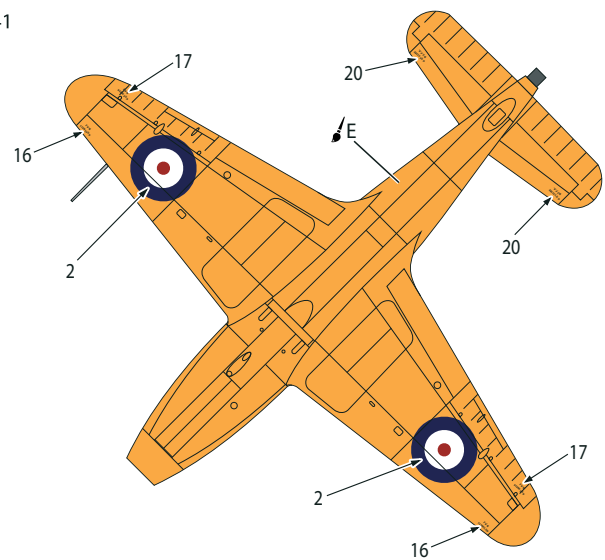
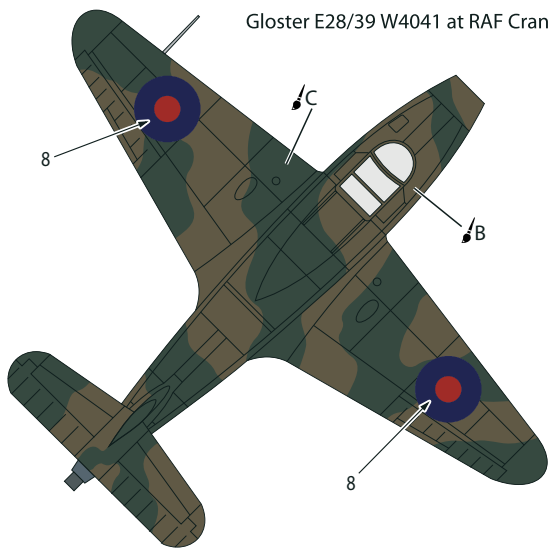

②

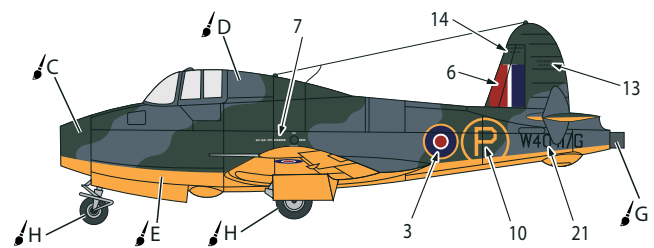
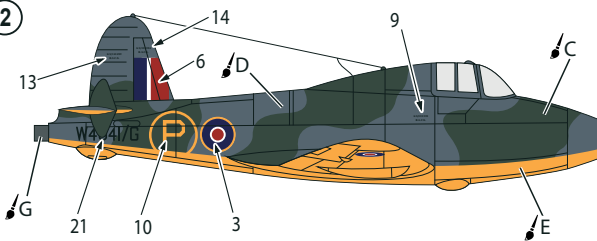

Gloster E28/39 W4041 at RAE Farnborough, December 1944

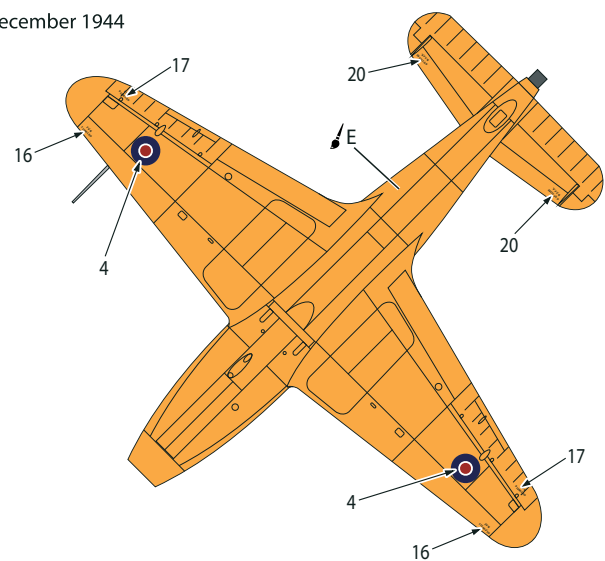
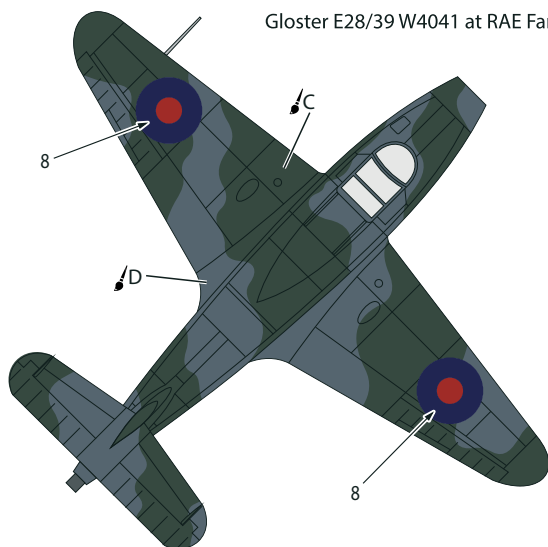



A
HUMBROL 56
ALUMINIUM



B
HUMBROL 29
DARK EARTH



C
HUMBROL 116
DARK GREEN



D
HUMBROL 106
OCEAN GREY



E
HUMBROL 188
TRAINER YELLOW



F
HUMBROL 70
DULL RED



G
HUMBROL 27004
GUN METAL



H
HUMBROL 33
BLACK

3

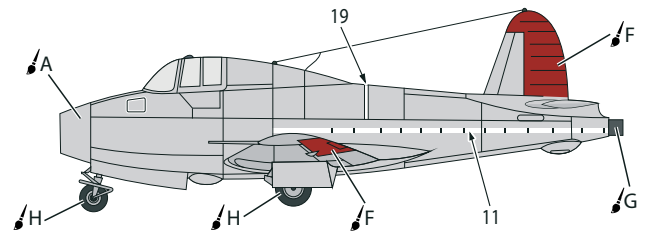
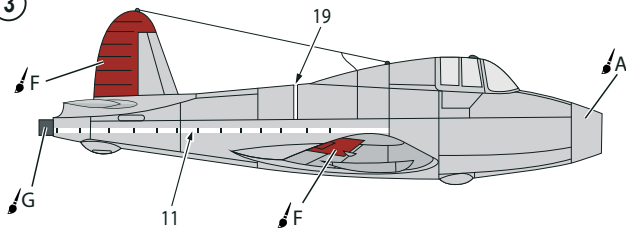

Gloster E28/39 W4041 at Brockworth, April 1941

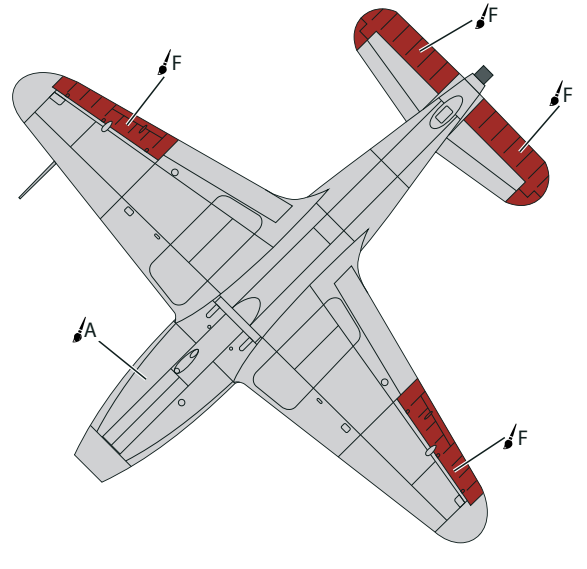
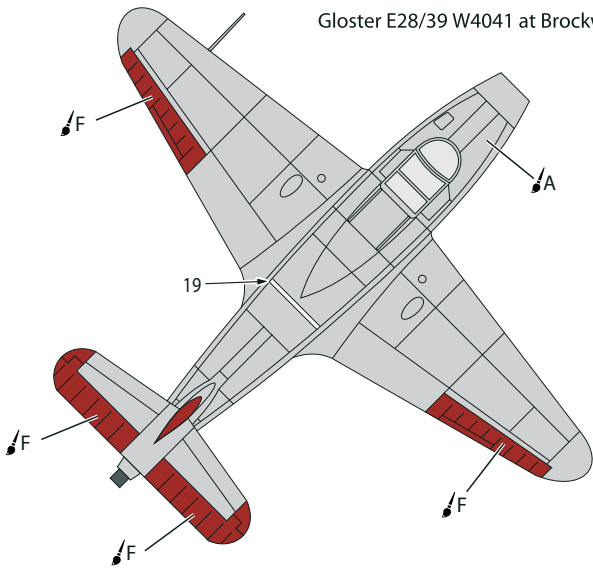

4

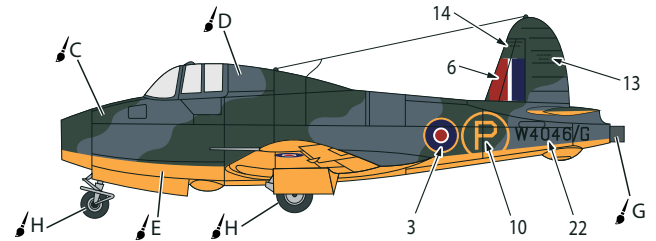
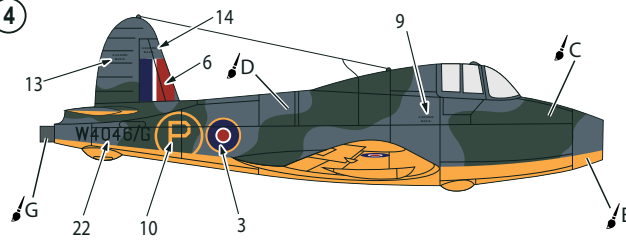

Gloster E28/39 W4046 at RAE Farnborough, July 1943

