

Grumman® Wildcat™ is a trademark of Northrop Grumman Systems Corporation and is used under license by Arma Hobby

Uwaga!

Przed rozpoczęciem pracy dokładnie przeczytaj instrukcję. Zachowaj zasady bezpieczeństwa przy pracy z łatwopalnym klejem i farbami! Trzymaj model z dala od małych dzieci. Nie pozwalaj im brać do ust/nosa części plastikowych lub naciągać na głowę torebek plastikowych!

Wsparcie klienta: W przypadku jakichkolwiek problemów z modelem bez wahania wypelnij formularz zgłoszenia na stronie:

<http://www.armahobby.pl/webpage/wsparcie-faq.html>

Warning!

Before you start, please read the instructions carefully. Working with flammable glue and/or paint, please follow the safety recommendation of the manufacturers. Keep out of reach of small children! Do not allow them to place plastic parts in their mouths or noses or to pull plastic bags over their heads.

Customer care: In case of any problems with the model, please do not hesitate to contact us and fill the claim form on our website:

<http://www.armahobby.com/webpage/wsparcie-faq.html>

W połowie 1943 r. nastąpił bardzo szybki rozwój liczebny floty lotniskowców eskortowych U.S. Navy. W ciągu około roku wprowadzono do służby 50 okrętów samego tylko typu „Casablanca” oraz mniejsze liczby z innych typów. Na pokładzie takiego lotniskowca stacjonowała mieszana eskadra lotnicza (Composite Squadron, VC) wyposażona w dziewięć samolotów bombowo-torpedowych Avenger i 18 myśliwców Wildcat. Wypracowano dla nich taktykę zwalczania okrętów podwodnych zwaną Hunter-Killer.

W macierzystych zakładach Grummana zaprzestano produkcji tych samolotów na rzecz myśliwców Hellcat, przeznaczonych na lotniskowce uderzeniowe. Produkcję Wildcatów i Avengersów przeniesiono do zakładów General Motors. Wildcat z General Motors dla lotniskowców eskortowych oznaczony FM-1 był odpowiednikiem F4F-4 Grummana, ale bez zewnętrznych karabinów maszynowych. Zmianie uległa ilość amunicji do pozostałych km-ów i powiększona została pokrywa luku amunicji na spodzie skrzydła. Kolejna wersja, FM-2, miała mocniejszy silnik, ale bez sprężarki do działania na wysokim pułapie. Większy moment obrotowy śmigła zrównoważono powiększonym uszczerpieniem pionowym.

Samoloty FM-1/FM-2 służyły na lotniskowcach eskortowych do końca wojny. Brały udział w konwojach atlantyckich, osłonie i wsparciu desantów na Pacyfiku i zwalczaniu ataków Kamikaze. Brytyjski odpowiednik FM-1/FM-2, Wildcat V/Vi wziął udział w konwojach atlantyckich, desancie w Normandii i południowej Francji oraz w zwalczaniu niemieckiej żeglugi na wodach Norwegii. Samolot FM-2 okazał się godnym przeciwnikiem zarówno myśliwców Zero jak i Messerschmitt Bf-109G.

By mid-1943, the U.S. Navy had embarked on a programme of rapid expansion of its escort carrier fleet. Over the next year or so, 50 Casablanca-class escort carriers and varying numbers of other vessel types were put into service. Each of the carriers was home to a “Composite Squadron” (VC) comprising nine Avenger torpedo-bombers and eighteen Wildcat fighters. These units were specially trained for anti-submarine operations in the hunter-killer role. Grumman’s own plant soon ceased production of both aeroplane types in favour of the Hellcat fighter, which was intended for fleet aircraft carriers. The manufacture of Wildcats and Avengers was then transferred to General Motors. The Wildcats produced by General Motors for escort carriers, with the designation FM-1, were equivalent to Grumman’s F4F-4s, however they did not have the external machine guns. Other modifications concerned the quantity of ammunition provided for the remaining machine guns, and an enlarged ammunition compartment cover on the wing undersides. The next version, the FM-2, was fitted with a more powerful engine, although without a two-stage compressor for operation at higher altitudes. The propeller’s greater torque was counterbalanced by an enlarged vertical tail unit.

FM-1s/FM-2s served on escort carriers right until the end of the war. In the European theatre, they took part in Atlantic convoys, while in the Pacific Ocean theatre they provided cover and support for sea-borne landings and helped combat kamikaze attacks. The British equivalent of the FM-1/FM-2, the Wildcat V/Vi, played a prominent role in the Battle of the Atlantic, the landings in Normandy and the South of France, and in combating German shipping in Norwegian waters. The FM-2 turned out to be a worthy opponent for both the Zero and the Messerschmitt Bf-109G.

Podziękowania/Aknolegements: Tony O'Toole

Kalkomanie/Decals

Części przezroczyste/ Transparent parts

Części fototrawione/ Photo etched parts

Części plastikowe/Plastic parts

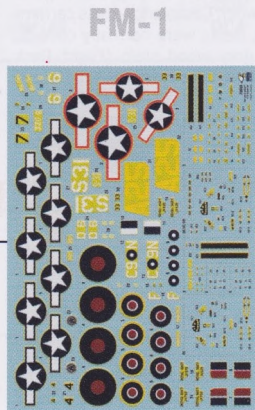

Ramka
/Frame **T**



Ramka
/Frame **T**



Ramka
/Frame **A**



Ramka
/Frame **A**

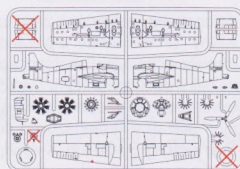

Ramka
/Frame **C**

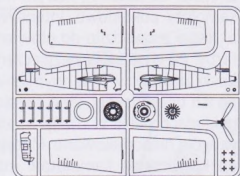

Ramka
/Frame **B**

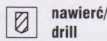
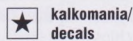
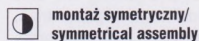

Manufacturer:

Arma Hobby S.C. Ostrobramska 101/200; 04-041 Warszawa, Poland
www.armahobby.pl; www.armahobby.com; kontakt1@armahobby.pl
 © 2021 Arma Hobby S.C. all rights reserved

Kolory farb/ Paint colours		Hataka	AK RC	Lifecolor	AMMO	Humbrol	Vallejo	Tamiya	Kolory farb/ Paint colours	Hataka	AK RC	Lifecolor	AMMO	Humbrol	Vallejo	Tamiya	
A	Matt Black FS37038	HTK-C100	RC001	LC02	046	33	71.057	XF-1	J	Intermediate Blue FS3164	HTK-C027	RC235	UA045	228	144	71.220	*XF-18
B	Aluminium FS17178	HTK-C106	RC020	LC24	194	56	71.062	XF-16	K	Dark Gull Grey FS36231	HTK-C044	RC247	UA033	205	140	71.277	XF-54
C	Interior Green FS34151	HTK-C211	RC028	UA004	220	151	71.137	-	L	Light Gull Grey FS36440	HTK-C048	RC220	UA025	241	129	71.121	*XF-14
D	Engine Grey FS36081	HTK-C030	RC243	UA030	-	123	71.123	*XF-22	M	BS Extra Dark Grey FS36440	HTK-C140	RC295	UA109	-	123	71.110	XF-54
E	Gunmetal	HTK-C106	RC015	LC26	045	53	71.073	X-10	N	BS Dark Slate Grey	HTK-C202	RC294	-	-	224	71.309	-
F	Insignia White FS37925	HTK-C049	RC004	LC01	050	34	71.001	XF-2	O	Sky Type S	HTK-C026	RC290	UA095	243	90	71.321	*XF-12
G	Yellow	HTK-C066	RC007	LC53	125	154	71.078	XF-3	P	Olive Drab ANA613/FS34130	HTK-A004	RC259	UA005	237	155	71.316	XF-82
H	Semi-gloss Sea Blue FS15042	HTK-C006	RC257	UA044	227	181	71.295	XF-17	R	SEA GREY ANA603/FS36118	HTK-C031	RC244	*UA605	204	*123	71.097	-
I	Gloss Sea Blue FS15042	HTK-C001	RC258	UA044	227	181	71.295	XF-17	S	SKY ANA610/DuPont 71-021	HTK-C039	RC254	UA021	226	28	71.296	*XF-19

*Kolor zbliżony/similar colour

Pokład lotniskowca eskortowego U.S. Navy

Dwa wycinki pokładu lotniskowca eskortowego w niniejszym zestawie wzorowane są na pokładzie okrętu typu Casablanca (numery CVE-55-CVE-104), najpopularniejszym wśród tej klasy jednostek pływających. Pierwszy wycinek przedstawia pokład w środkowej sekcji z imitacją naciągów lin do hamowania samolotów. Drugi fragment to pokład dziobowy, z fragmentem podnośnika wynoszącego samoloty z hangaru oraz z tylną sekcją kanatu katapulty. Na pokładach można ustawić samoloty FM-1/FM-2 Wildcat i TBF/TBM Avenger. Na lotniskowcach eskortowych sporadycznie pojawiały się w warunkach bojowych inne typy samolotów U.S. Navy i U.S. Marines. Dodatkową rolę tych okrętów było transportowanie samolotów z zaplecza w rejon frontu. W ten sposób podróżowały np. całe skrzydła myśliwskie P-47 Thunderbolt i P-51 Mustang, oraz uzupełnienia wszelkich typów samolotów, w tym wielosilnikowych.

Kolorystyka pokładów zmieniała się podczas wojny. W momencie wprowadzenia do użycia lotniskowców typu Casablanca pokłady pokrywano bejca do drewna Flight Deck Stain 21 w kolorze ciemnoszaroniebieskim, po wytopieniu podobnym do farby kamuflażowej do okrętów Ocean Grey 50 (ok. FS 36176, HTK-A158, Lifecolor UA621). Od połowy 1944 roku pokład malowano bejca o takim samym oznaczeniu Flight Deck Stain 21, ale w nowym kolorze granatowym, podobnym do matowego Sea Blue (FS35042, HTK-A001, Lifecolor LC-UA044), którym malowano od góry samoloty pokładowe. Intensywne użytkowanie okrętów prowadziło do płowienia i ścierania się farby. Ze względów bezpieczeństwa drewniane deski pokładów były wymieniane natychmiast po ich uszkodzeniu, stąd często zdarzały się na pokładach deski w różnych odcieniach, a także w ogóle niepomalowane. Metalowe okucia i listwy z zaczepami do kotwiczenia samolotów malowano na kolor pokładu lub kamuflażu okrętu. Mogły też pozostać w kolorze metalu. Pasy na pokładzie i numer lotniskowca malowano kolorem czarnym, żółtym lub białym na szarym tle albo szarym, żółtym lub białym na granatowym tle.

Podczas malowania pokładu warto najpierw zabezpieczyć miękkie drewno blyszczącym lakierem bezbarwnym lub ModPodge. Po wyschnięciu lakieru przeszliżować ewentualne wiórki drewna wnetą stalową. Elementy metalowe pokryć warstwą surfacera i wygładzić, następnie pomalować na kolor metalu. Deski malować na kolor bejcy, odpowiednio stosując różne techniki weatheringu.

The Deck of a U.S. Navy Escort Carrier

The two sections of deck presented in the kit are modelled after Casablanca-class vessels (the most numerous of the various escort carriers classes, hull numbers CVE-55 – CVE-104). The first section shows the middle portion of the deck, complete with mock-ups of arrester wire tensioners. The second is a replica of the prow, with a fragment of the hangar elevator and the rear segment of the catapult channel. FM-1/ FM-2 Wildcats and TBF/TBM Avengers can be placed on the decks. Sporadically, in the course of warfare, escort carriers would receive other types of aircraft used by the U.S. Navy and U.S. Marines. They were also tasked with transporting aircraft from rear echelon areas to the front line. Among others, they conveyed entire fighter wings of P-47 Thunderbolts and P-51 Mustangs, and also other aircraft types, including multi-engined bombers.

The colouring of their decks changed during the war. At the time when Casablanca-class carriers were introduced, decks were normally covered with dark blue-grey wood stain (Flight Deck Stain 21), which once faded resembled the Ocean Grey 50 ship camouflage paint (approx. FS 36176, HTK-A158, Lifecolor UA621). From mid-1944, the Flight Deck Stain 21 received a new colour – navy blue – which was similar to the matte Sea Blue (FS35042, HTK-A001, Lifecolor LC-UA044) applied to the upper sides of carrier-based aircraft. The intense usage of vessels caused the paint to fade and wear away. For reasons of safety, the wooden deck boards were replaced immediately after sustaining damage, and thus it was common for decks to have boards that were of different hues, or even unpainted. The metal fittings and strips with catches for anchoring aeroplanes were painted in the colour of the deck or in the camouflage colour of the ship. They could also be left in their original metal colour. The landing strips markings of the flight deck were painted in black, yellow or white on a grey background, or in grey, yellow or white against a dark blue background.

Before you start painting, we recommend sealing the soft wood with a clear gloss varnish or ModPodge. When it dries, remove any wood chips using steel wool. Cover metal elements with a layer of surfacer, smooth it out, and then paint in a metal colour. The boards should receive a wood stain colour, and be appropriately weathered.

Zobacz więcej/see more at: <http://armahobbynews.pl/flight-deck/>

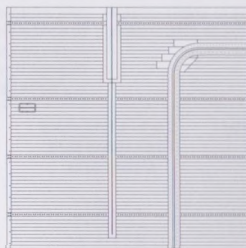

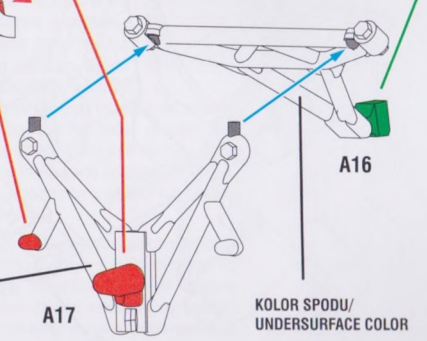
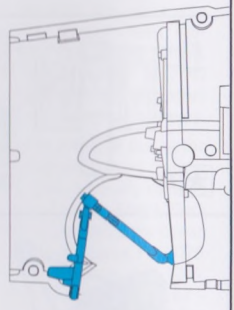
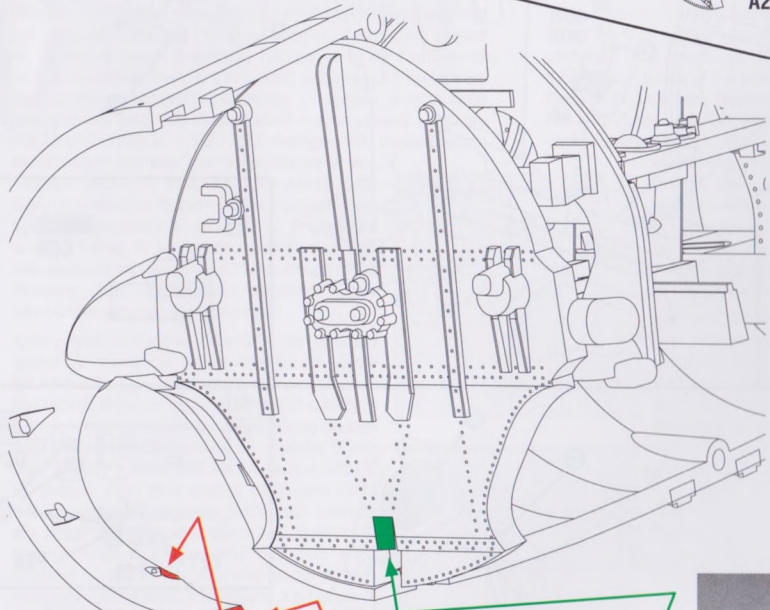
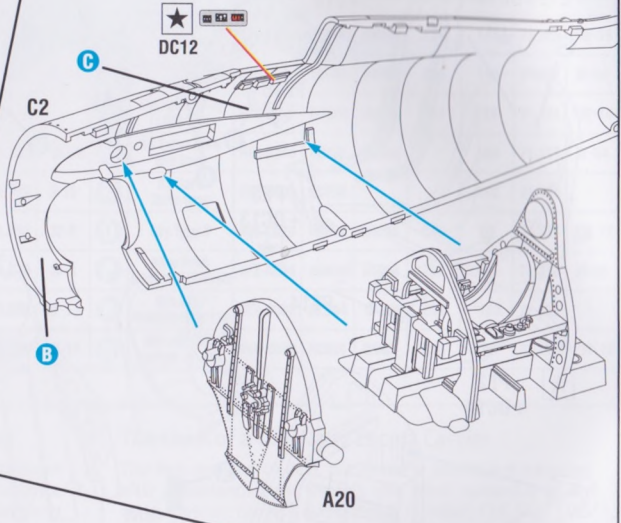
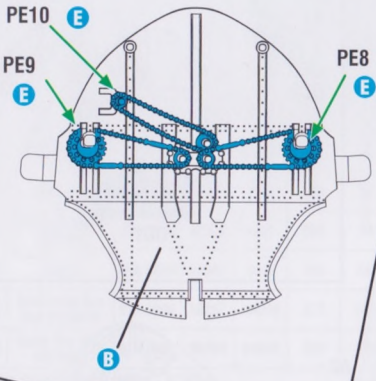

KOLOR SPODU/
UNDERSURFACE COLOR

KOLOR SPODU/
UNDERSURFACE COLOR

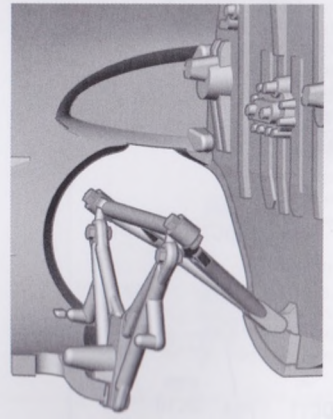

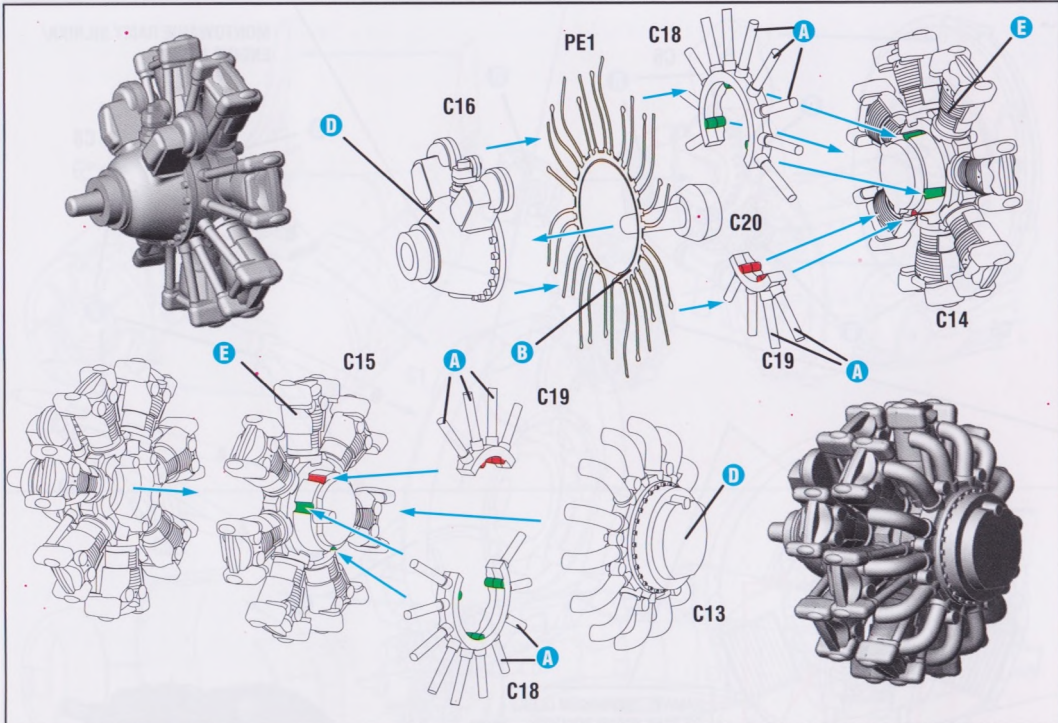

PE1

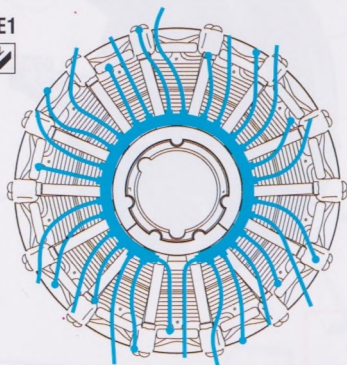

DOGNIJ PRZEWODY W ODPOWIEDNIE MIEJSCA/
BENT PE CABLES TO APPROPRIATE POSITIONS

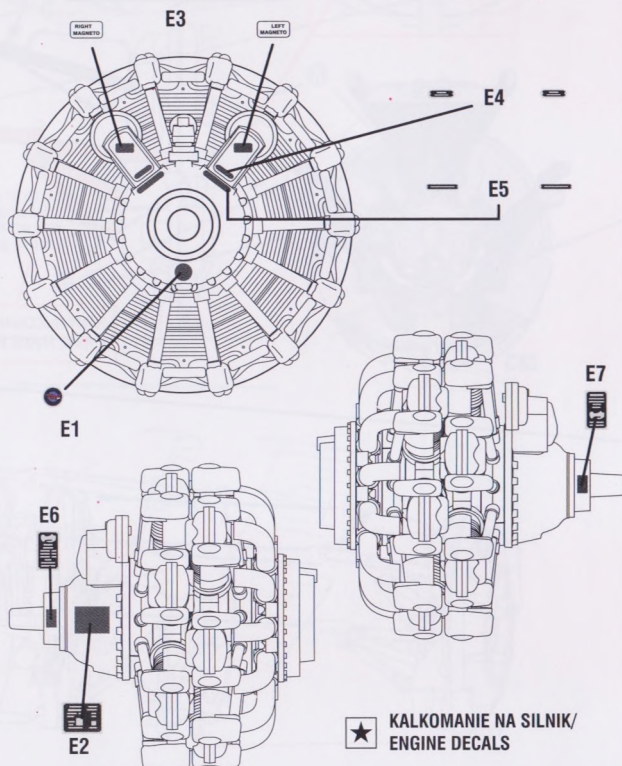
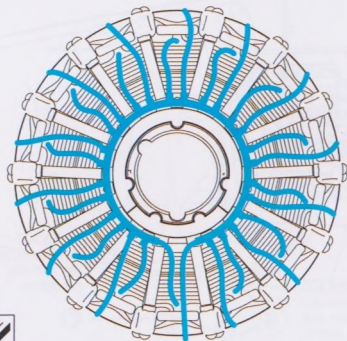

★ KALKOMANIE NA SILNIK/
ENGINE DECALS

**MONTOWANIE RAMY SILNIKA/
ENGINE MOUNT**

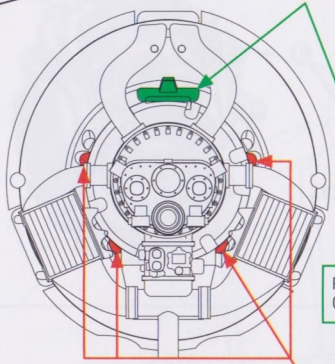
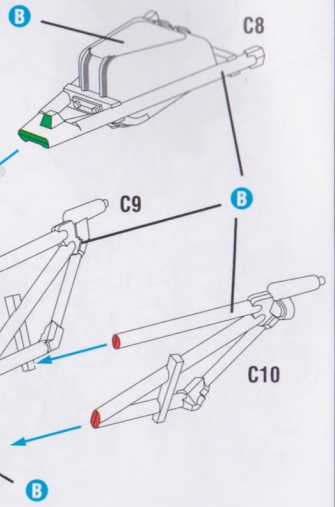
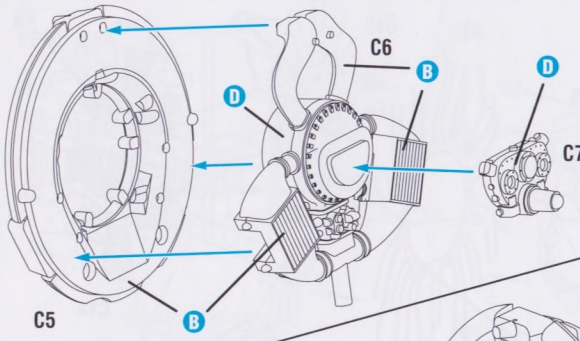

**RAMA ZE ZBIORNIKIEM OLEJU/
OIL TANK FRAME POSITION**

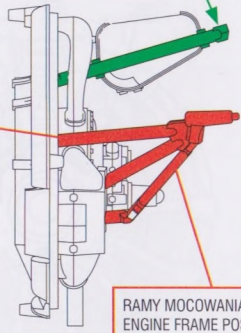
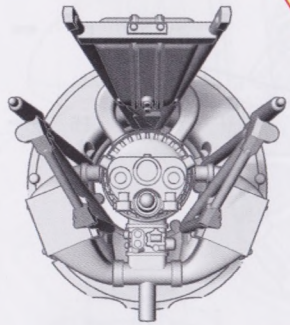

**RAMY MOCOWANIA SILNIKA/
ENGINE FRAME POSITION**

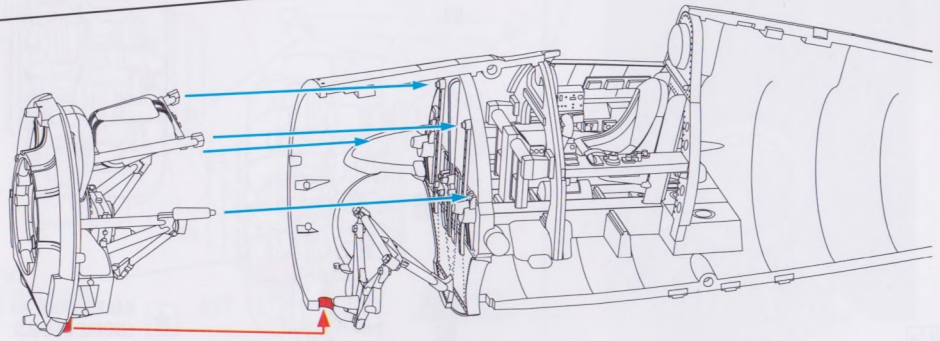
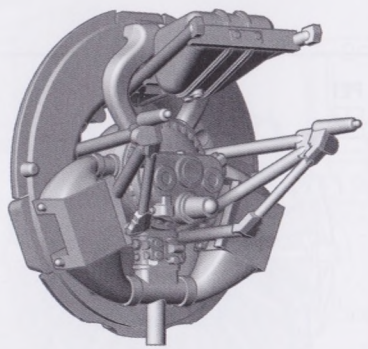

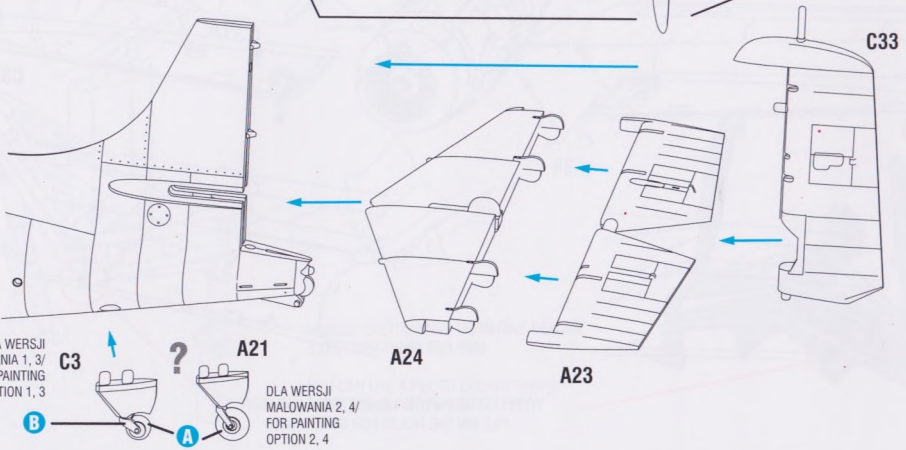
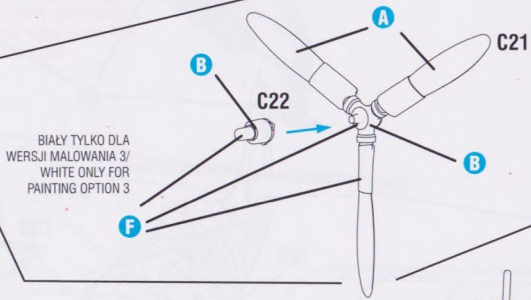
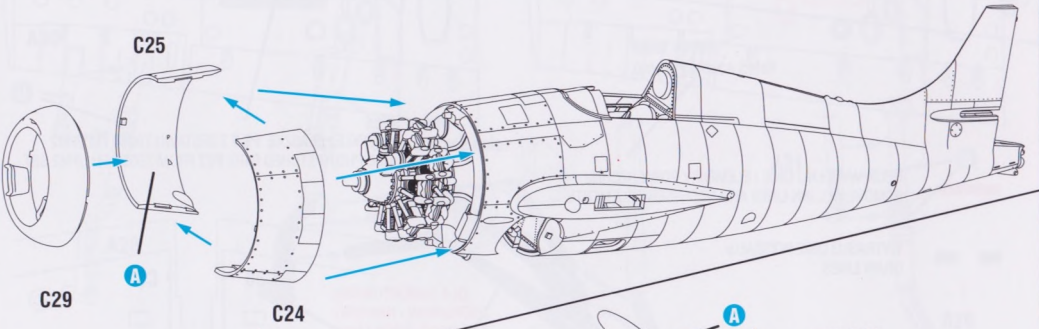
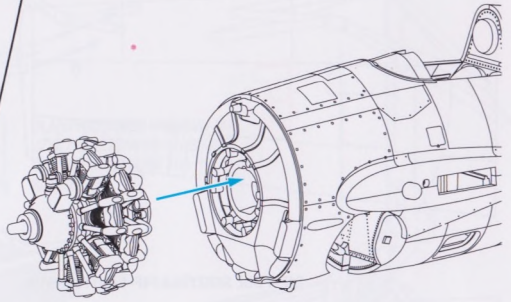
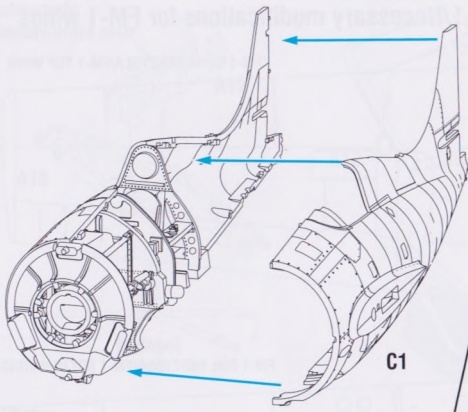

Niezbędne modyfikacje w obrębie skrzydeł dla FM-1/Necessary modifications for FM-1 wings

F4F-4 GÓRA SKRZYDŁA/F4F-4 TOP WING

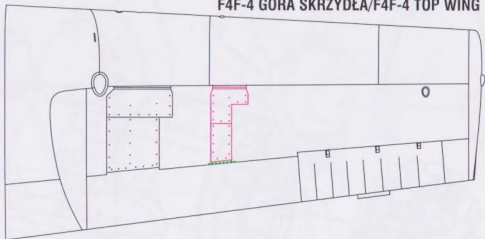

FM-1 GÓRA SKRZYDŁA/FM-1 TOP WING

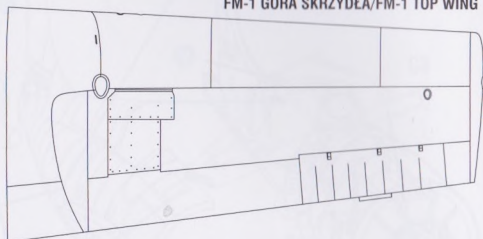

F4F-4 DÓŁ SKRZYDŁA/F4F-4 BOTTOM WING

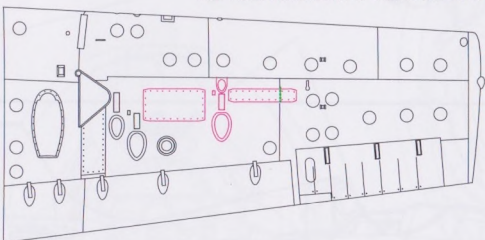

FM-1 DÓŁ SKRZYDŁA/FM-1 BOTTOM WING

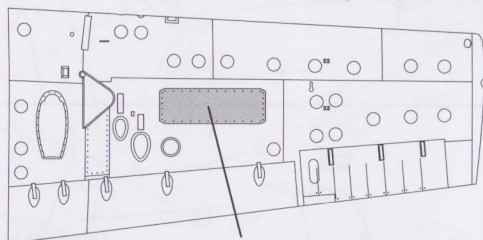

USUŃ/WYPEŁNIJ LINIE I ELEMENTY POWIERZCHNI/
REMOVE/FILL INN LINES AND NECESSARY ELEMENTS

WYTRASUJ LINIE PODZIAŁU/
DRAW LINES

PRZYKLEJ BLASZKĘ PE 7 Z ZESTAWU 70050 FM1/FM2
USE PHOTO ETCHED PART PE7 FROM 70050 FM1/FM2 SET

DLA ZAMONTOWANIA
ZBIORNIKÓW - NAWIERC/
FOR USING DROP TANKS
- DRILL HOLES

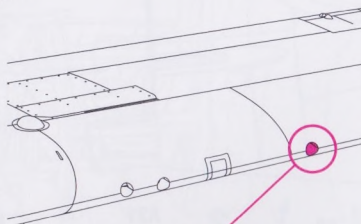
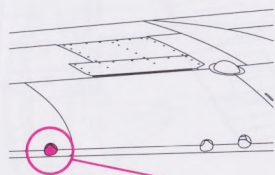
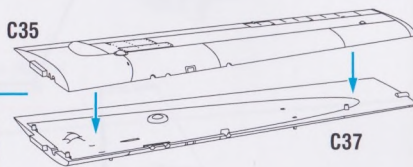
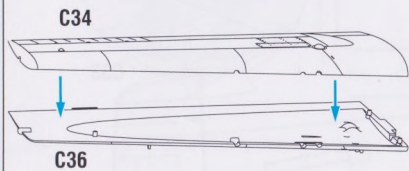
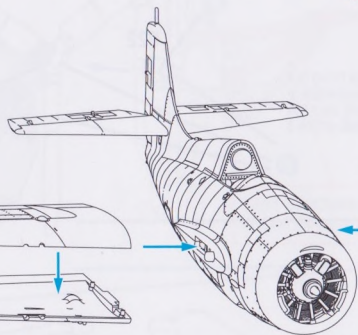
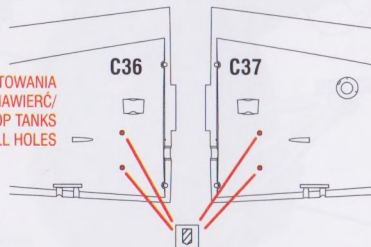

WYPEŁNIJ OTWORY NA ZEWNĘTRZNE KARABINY /
FILL INN THE HOLES FOR OUTER GUNS

kolor spodu /undersurface color

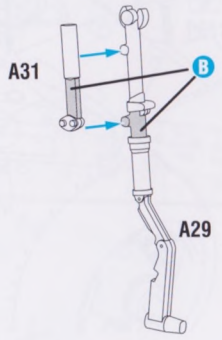
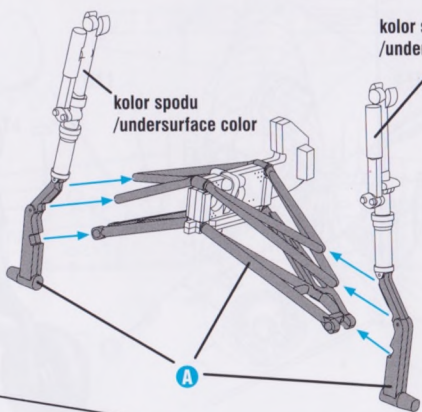
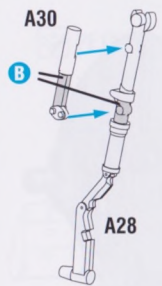
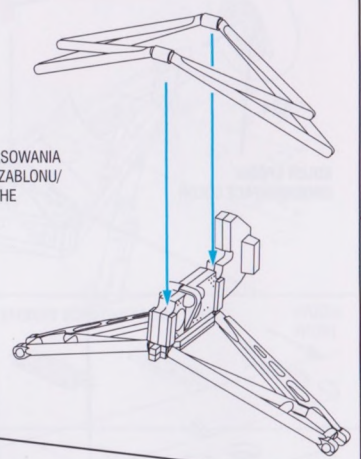
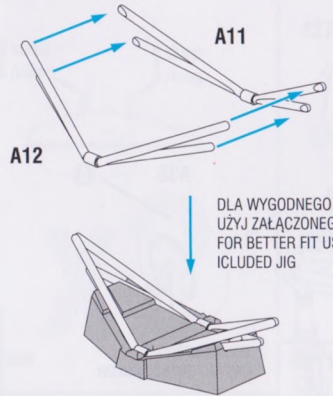
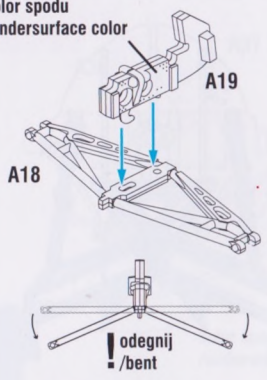

kolor spodu /undersurface color

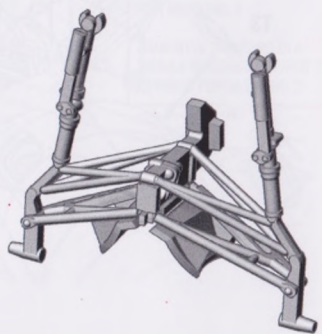
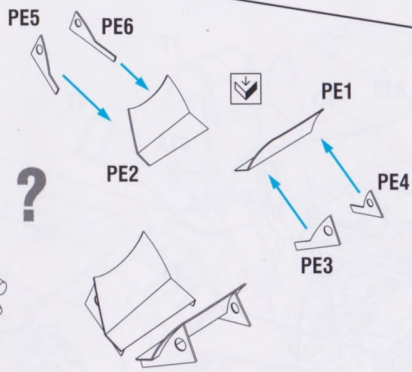
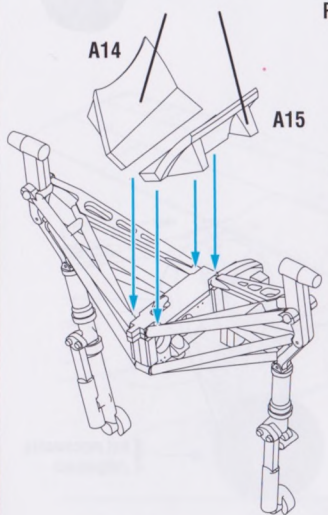

MOŻESZ ZASTOSOWAĆ METALOWE OSŁONY Z ZESTAWU 70050 FM1/FM2

YOU CAN USE A PHOTO ETCHED PARTS FROM 70050 FM1/FM2 SET

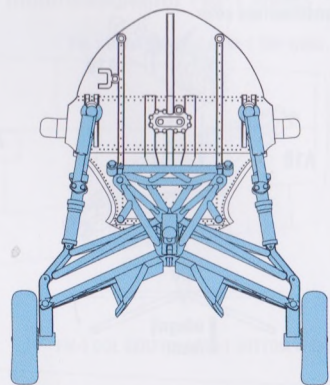
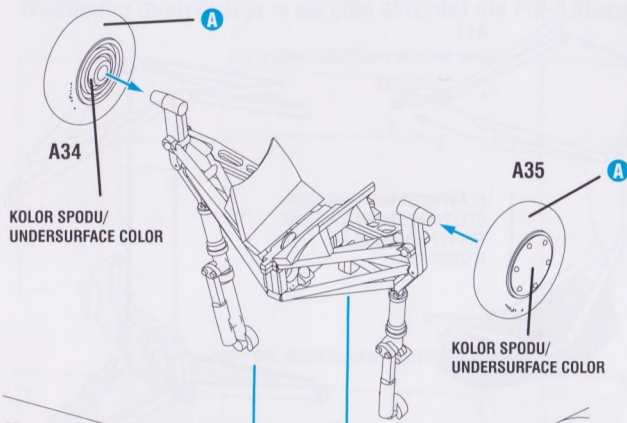

POMIĘTO CZĘŚCI FOTOTRAWIONE DLA LEPSZEJ
CZYTELNOŚCI/ PE PARTS WERE OMITTED FOR
CLEAR VISIBILITY PURPOSE

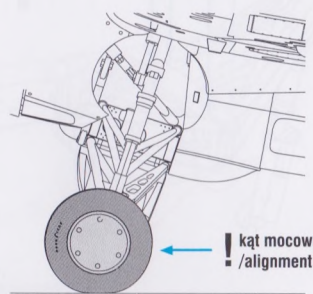
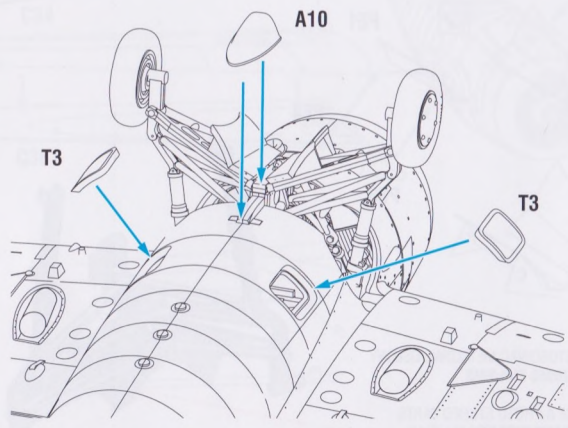
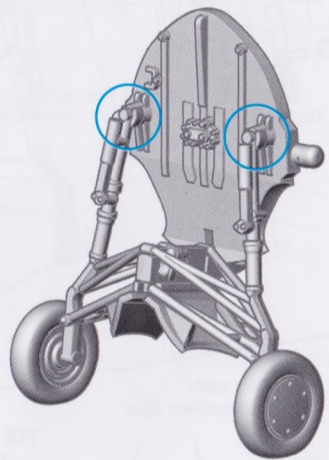
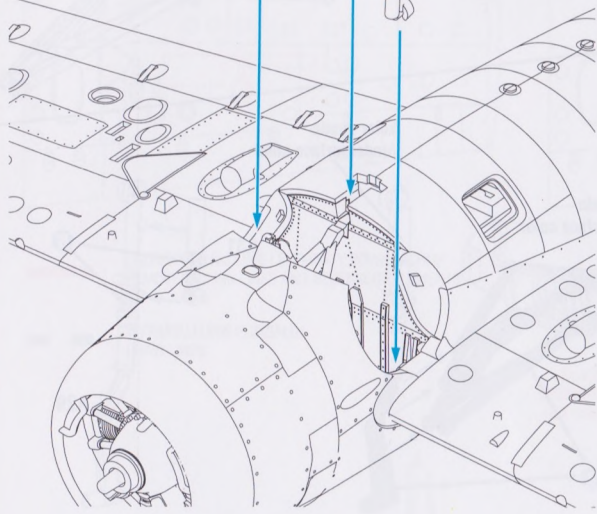

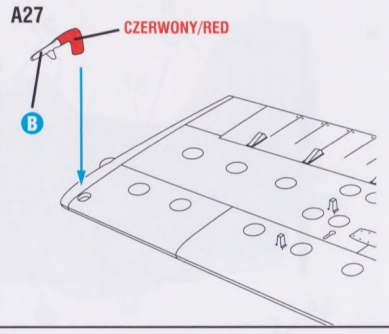
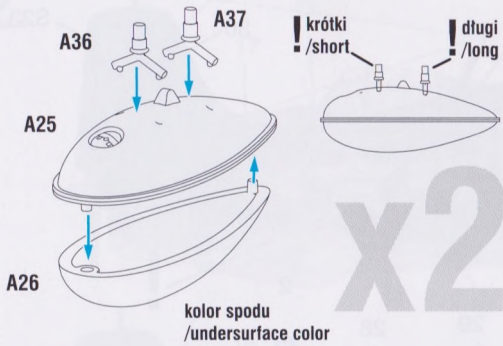

ZACZEPY BOMBOWE DLA WARIANTU MALOWANIA 3/ BOMB RACKS FOR MARKING 3

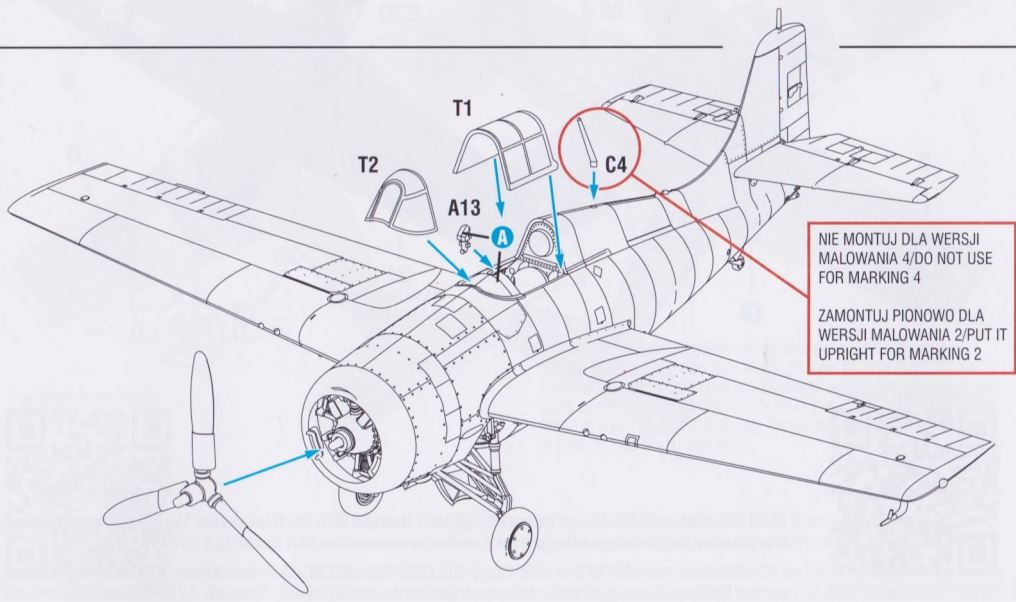
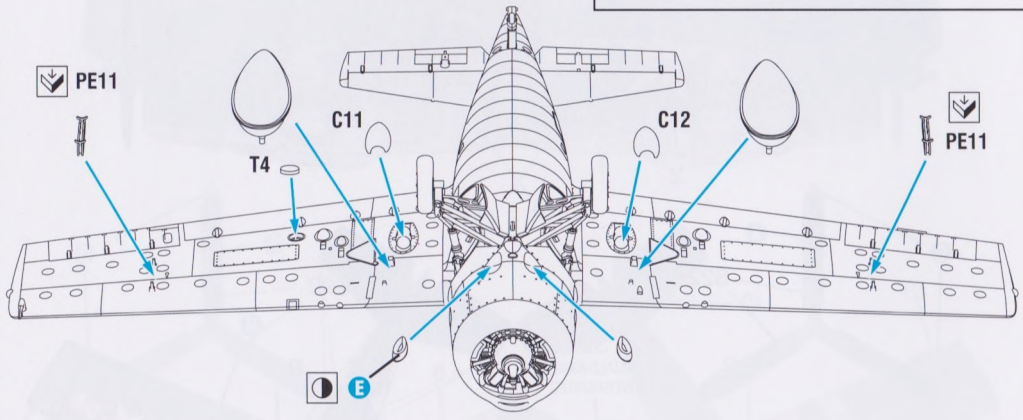
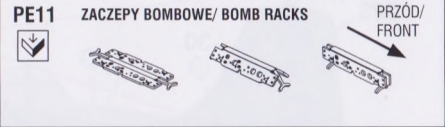

1.

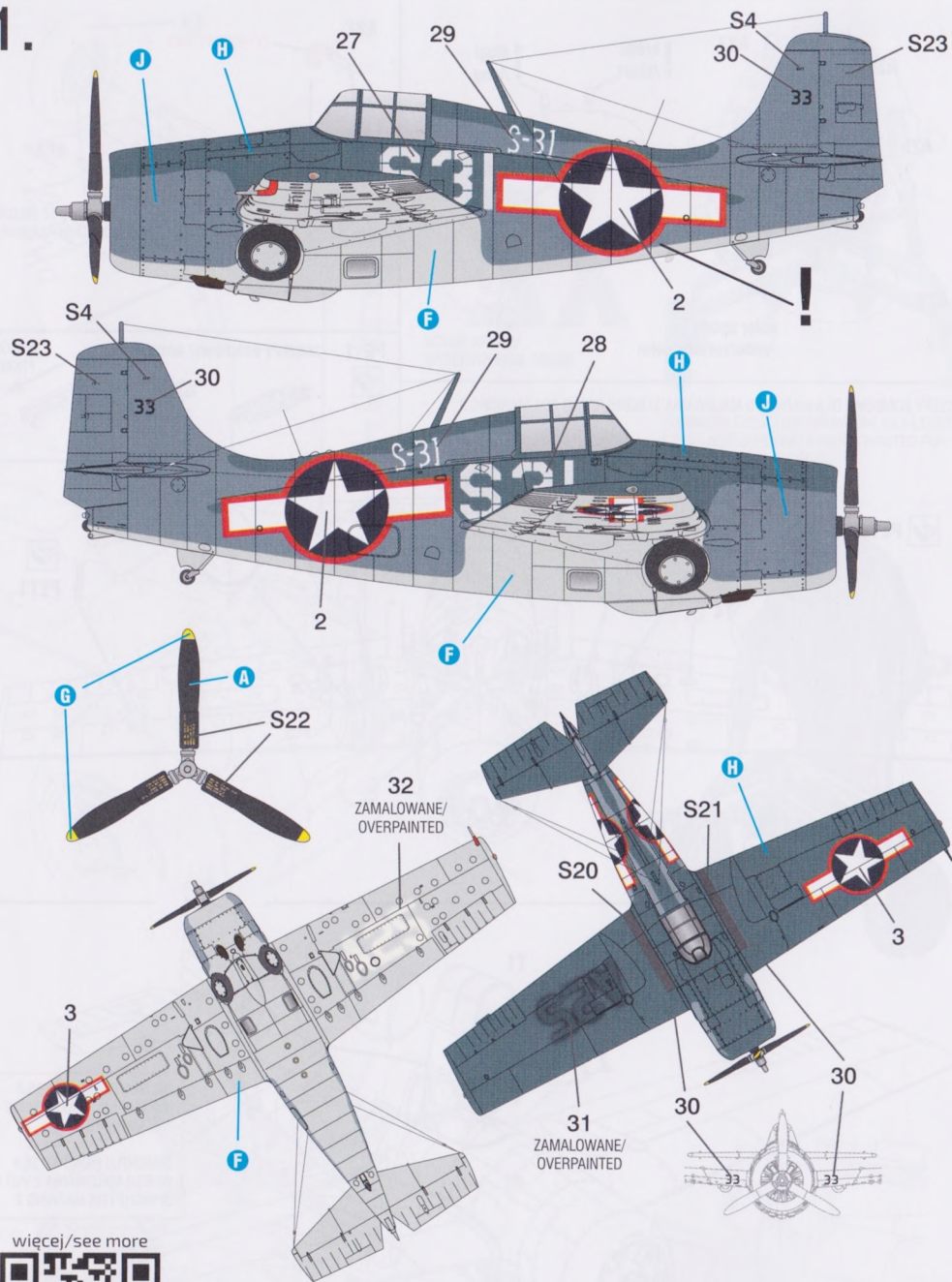

więcej/see more



<http://armahobbynews.pl/70050>

FM-1 Wildcat, nr A32/S31, eskadra VC-33, USS Nassau CVE-16, 6 września 1943 r. podczas treningu u wybrzeży Kalifornii, niedługo przed zaokrętowaniem na USS Coral Sea CVE-57.

FM-1 Wildcat, no. A32/S31, VC-33 squadron, USS Nassau CVE-16, 6 September 1943, during training on the California coast, shortly before embarkation on USS Coral Sea CVE-57.

2.

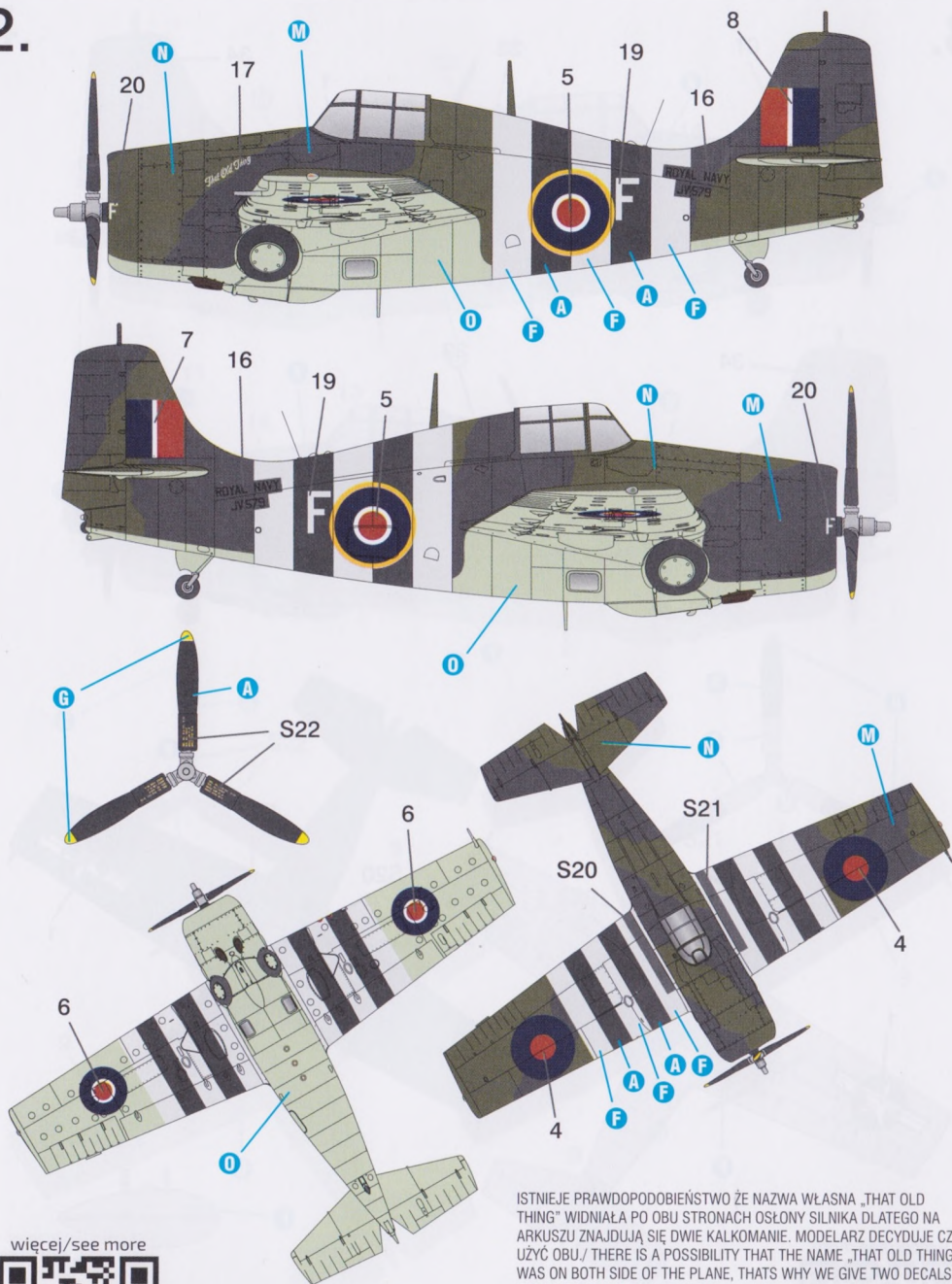

ISTNIEJE PRAWDOPODOBIENSTWO ŻE NAWAZA WŁASNA „THAT OLD THING” WIDNIAŁA PO OBU STRONACH OSŁONY SILNIKA DLATEGO NA ARKUSZU ZNAJDUJĄ SIĘ DWA KALKOMANIE. MODELARZ DECYDUJE CZY UŻYĆ OBU / THERE IS A POSSIBILITY THAT THE NAME „THAT OLD THING” WAS ON BOTH SIDE OF THE PLANE, THATS WHY WE GIVE TWO DECALS. IT'S UP TO YOU IF YOU USE BOTH.

wiecej/see more



<http://armahobbynews.pl/70050>

Wildcat V, nr JV579/F, „That Old Thing”, B46 dywizjon FAA, lotniskowiec HMS Trumpeter/lotnisko Eglinton. Jednostka brała udział w ostonie przeciwpodwodnej desantu w Normandii w czerwcu 1944 r.
 Wildcat V, no. JV579/F, “That Old Thing”, B46 Naval Air Squadron, aircraft carrier HMS Trumpeter/Eglinton airfield. The unit provided anti-submarine cover during the Normandy landings of June 1944.

3.

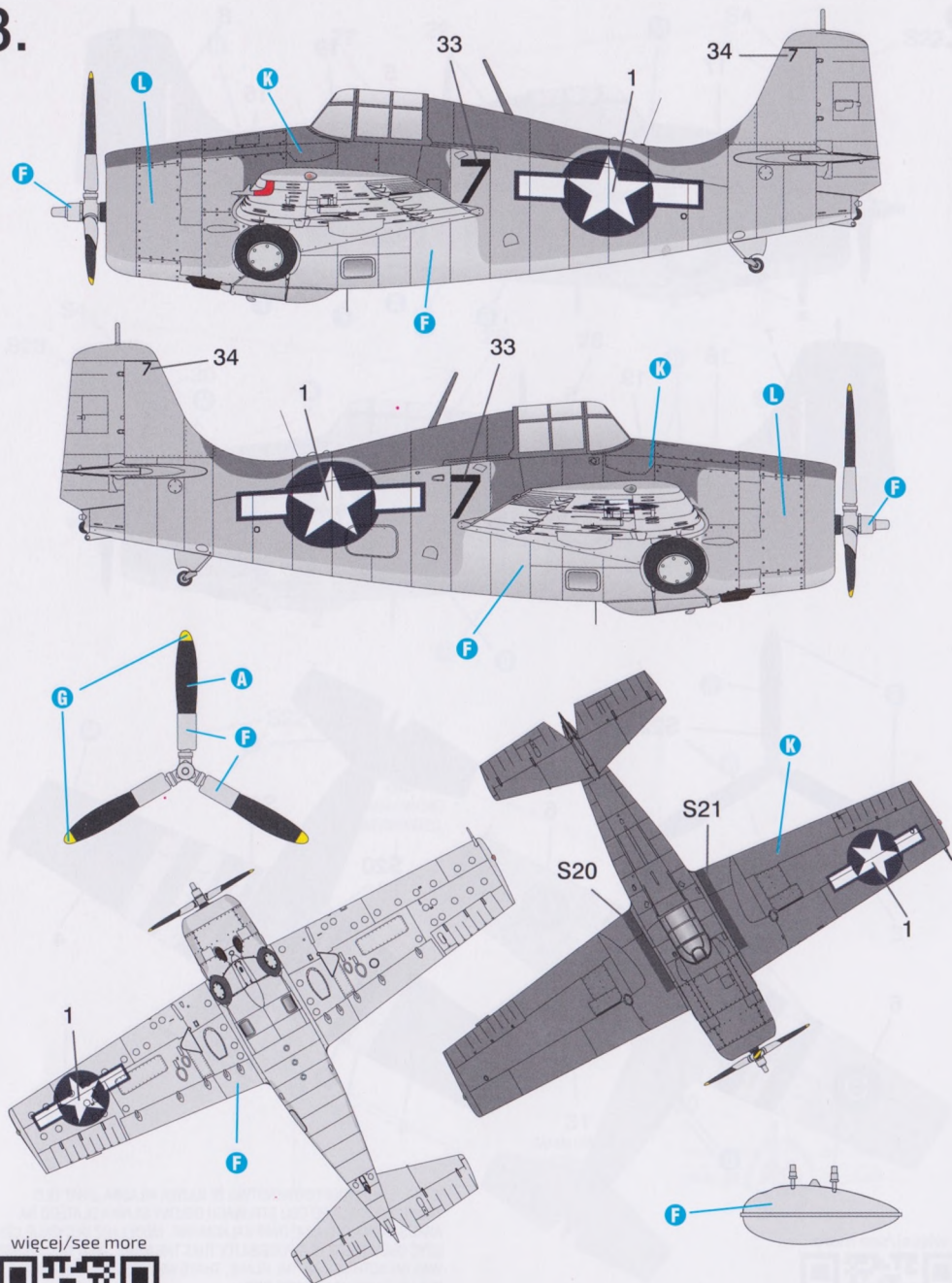

więcej/see more



<http://armahobbynews.pl/70050>

FM-1 Wildcat, nr 7, eskadra VC-6, USS Core CVE-13, 16 grudnia 1943 r. podczas patrolu przeciwpodwodnego na Północnym Atlantyku.

FM-1 Wildcat, no. 7, VC-6 squadron, USS Core CVE-13, 16 December 1943, during anti-submarine patrols over the North Atlantic.

4.

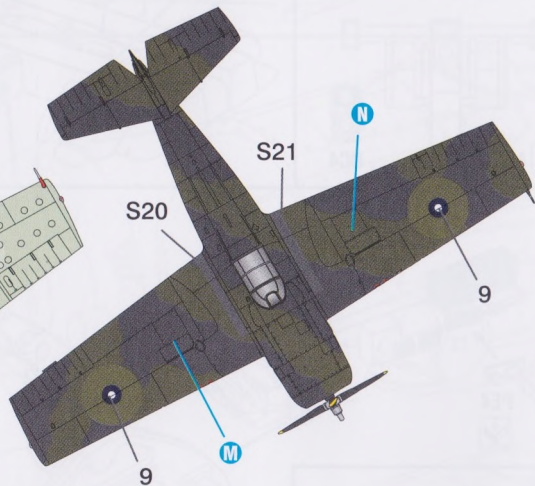
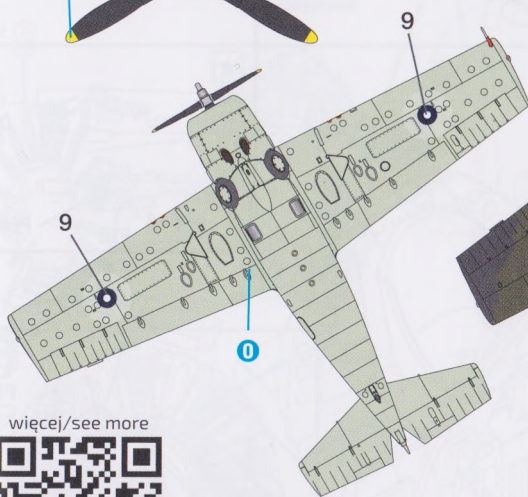
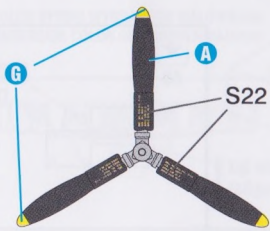
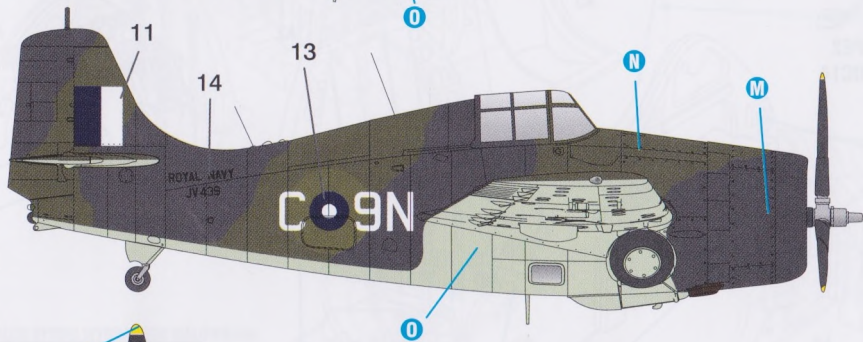
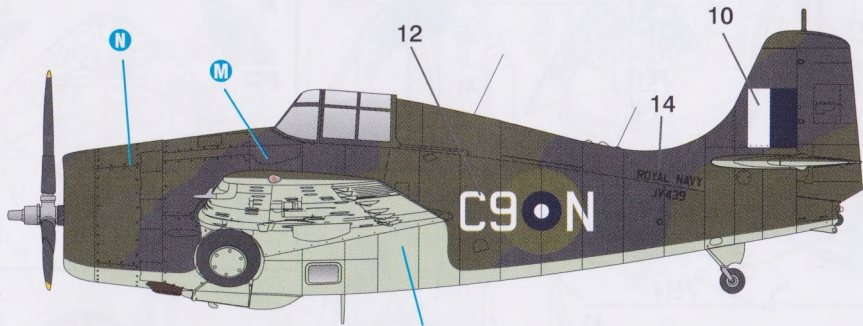

więcej/see more



<http://armahobbynews.pl/70050>

Wildcat V, nr JV439/C9-N, 733 dywizjon FAA, pilot Sub Lt Griffiths, lotnisko w Trincomalee, Cejlon 1945 r.

Wildcat V, no. JV439/C9-N, 733 Naval Air Squadron, piloted by Sub-Lieut. Griffiths, Trincomalee airfield, Ceylon, 1945.

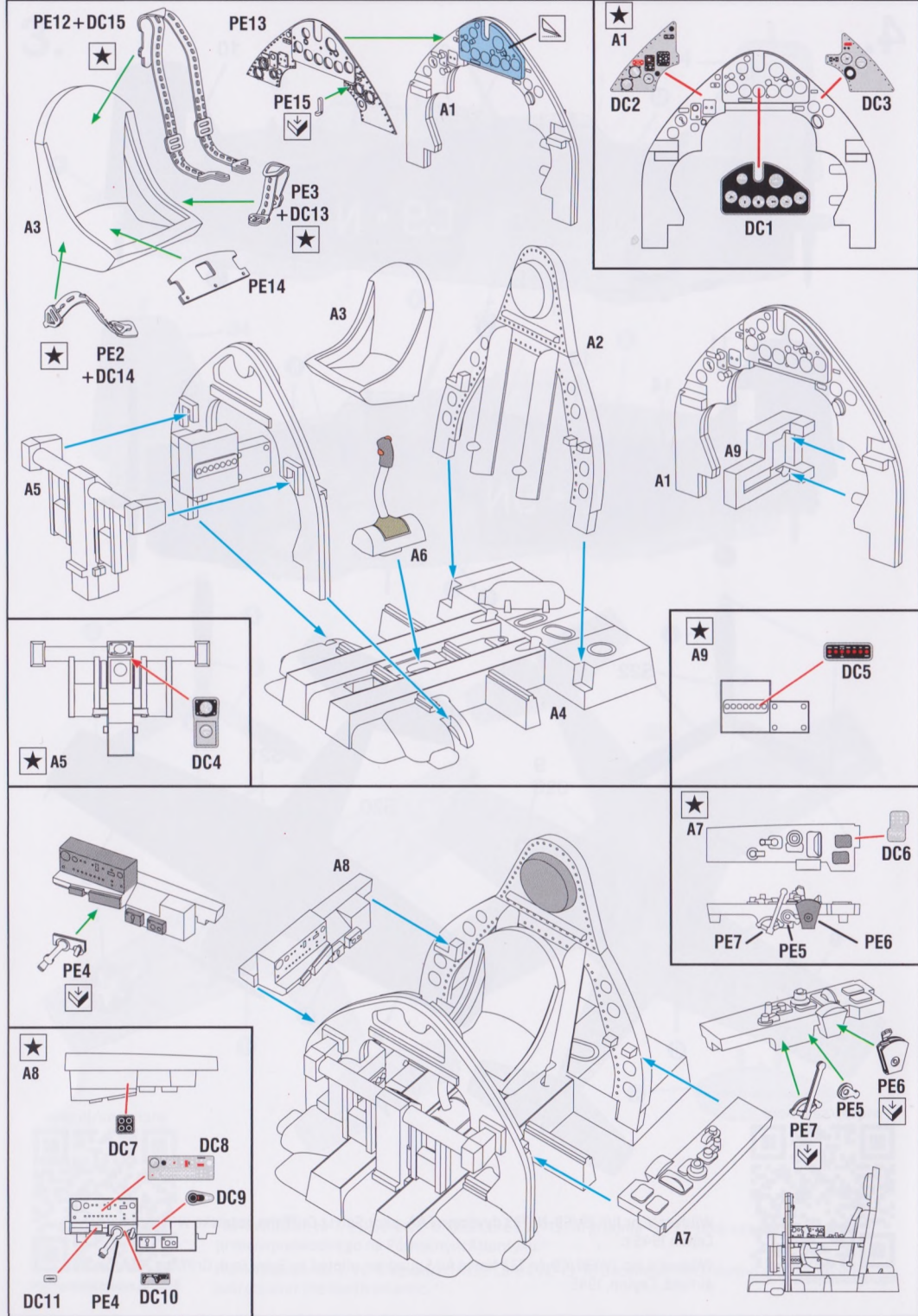

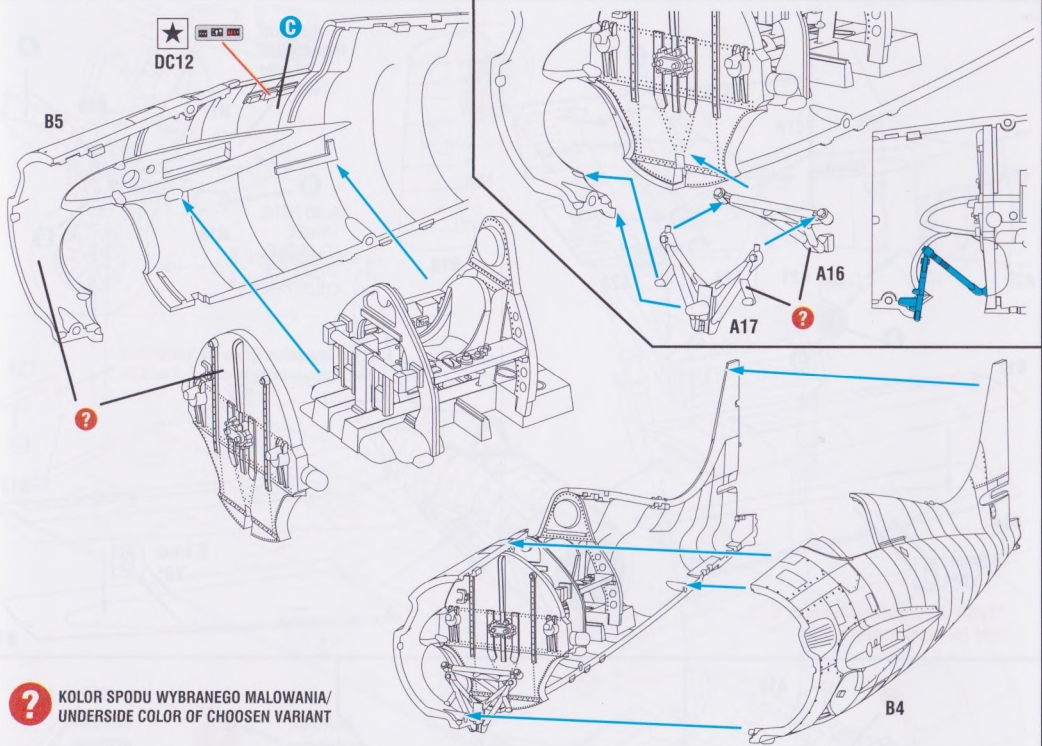

? KOLOR SPODU WYBRANEGO MALOWANIA/
UNDERSIDE COLOR OF CHOSEN VARIANT

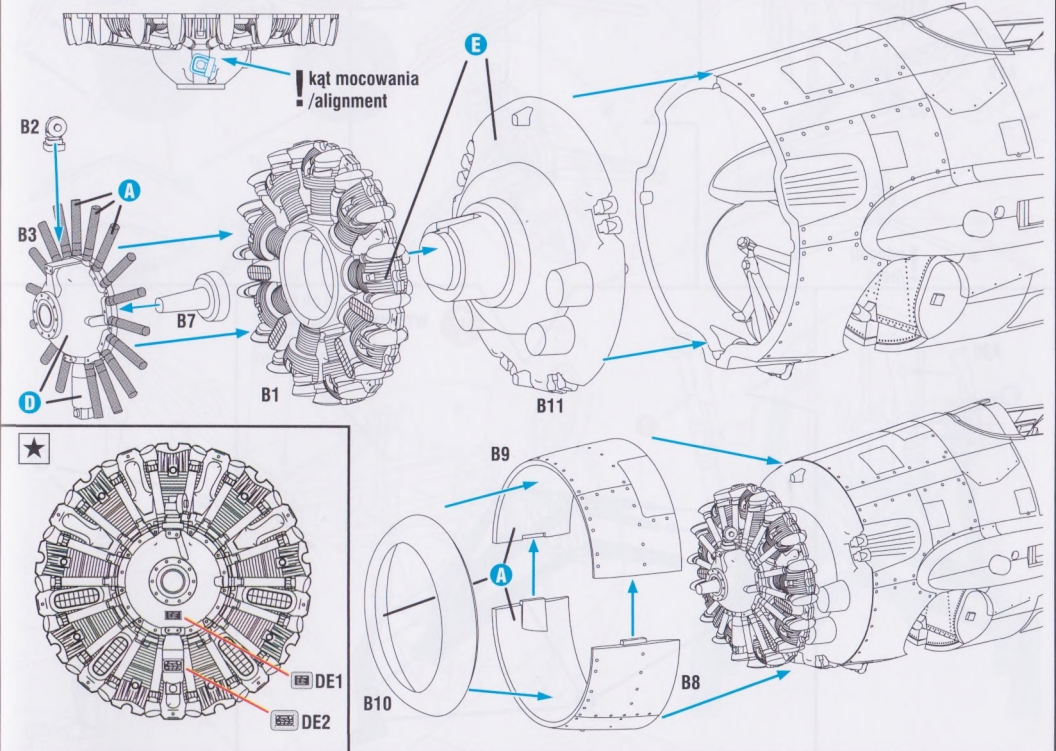

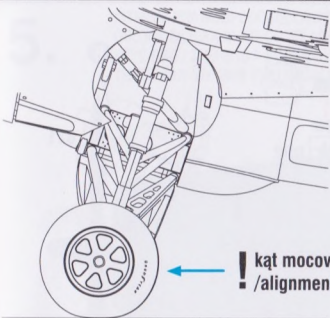

! kąt mocowania
/alignment

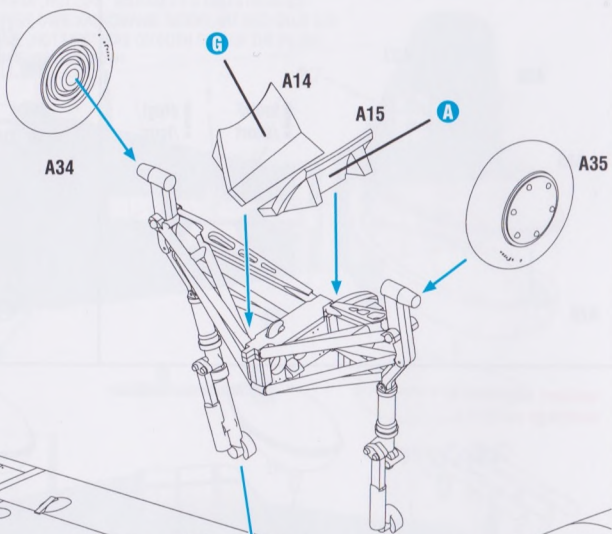

A27 **CZERWONY** dla wersji malowania 6, 7, 8/
RED for 6, 7, 8 color scheme

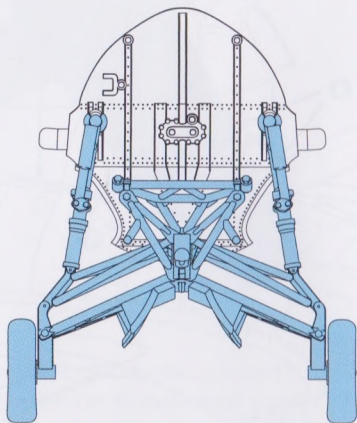
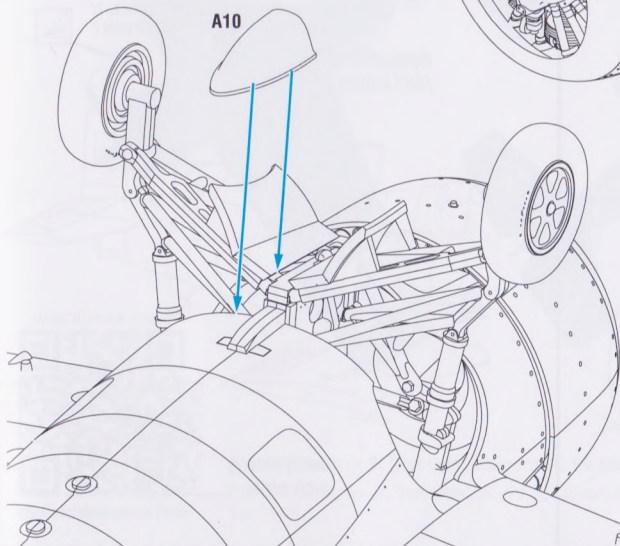
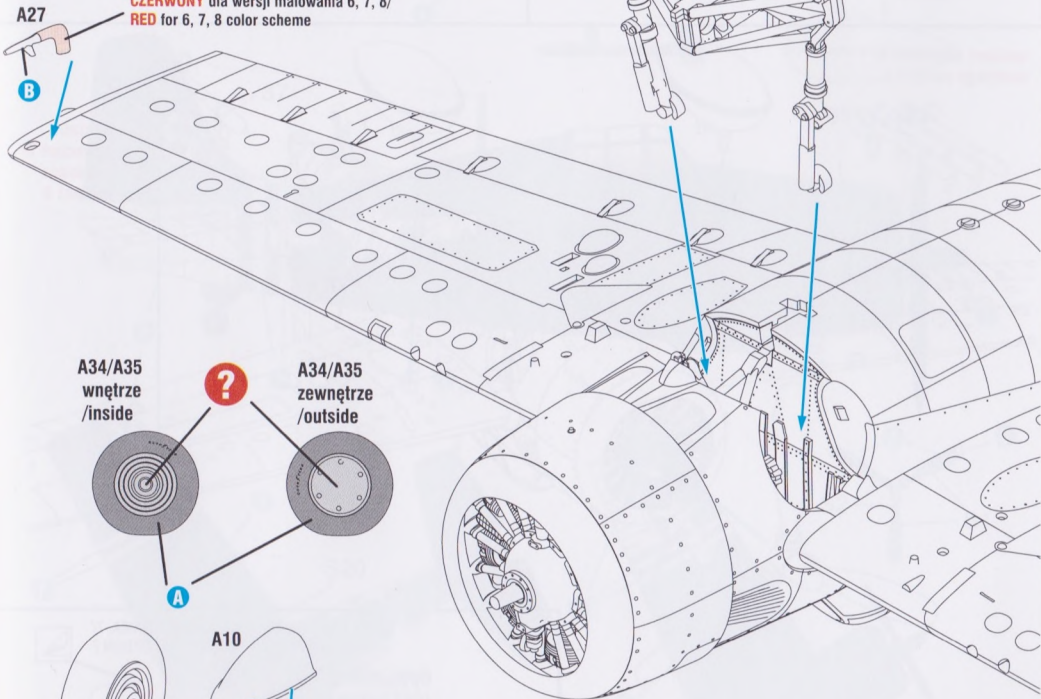

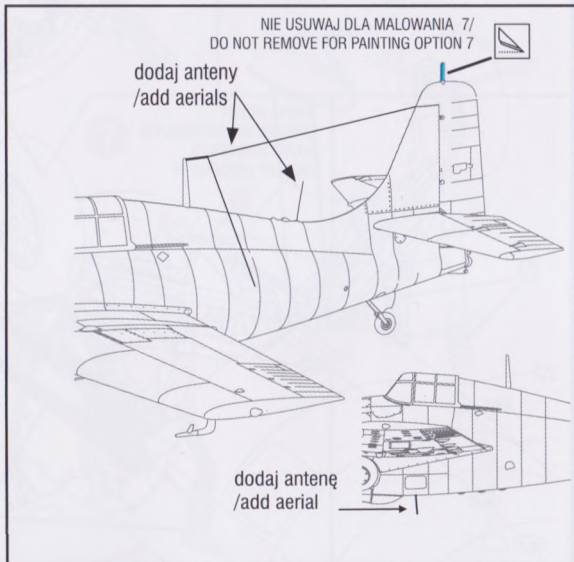
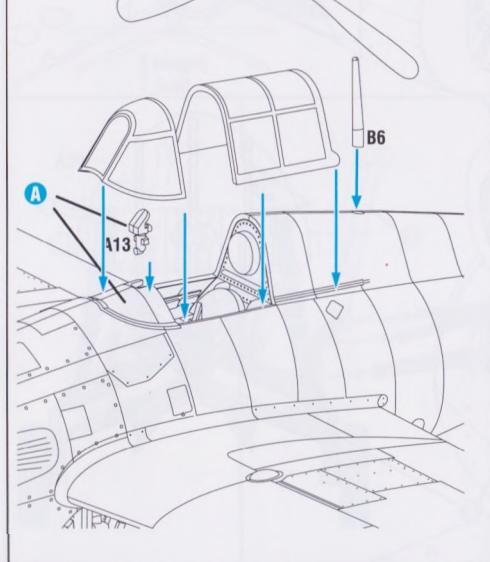
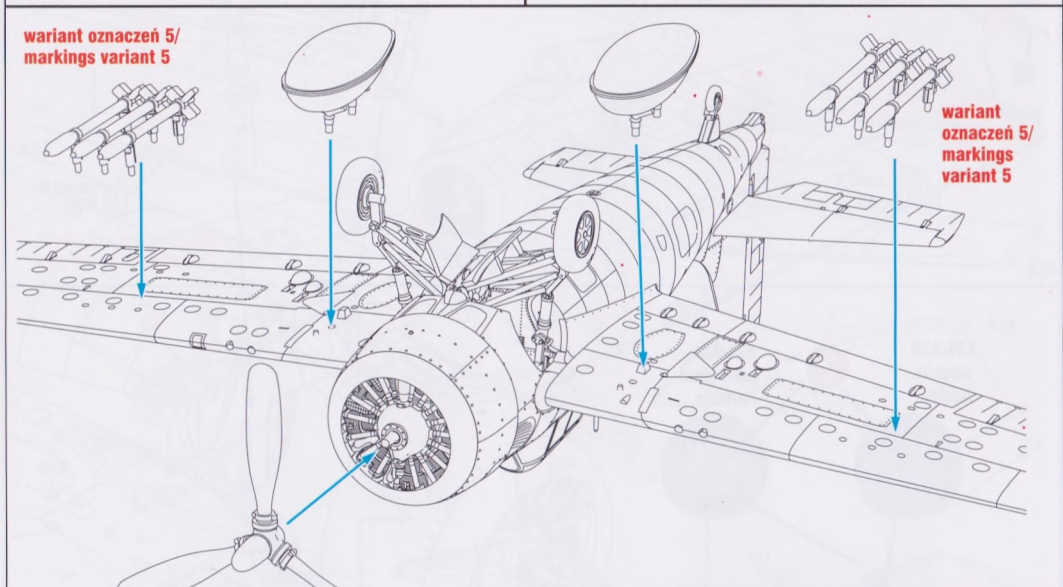
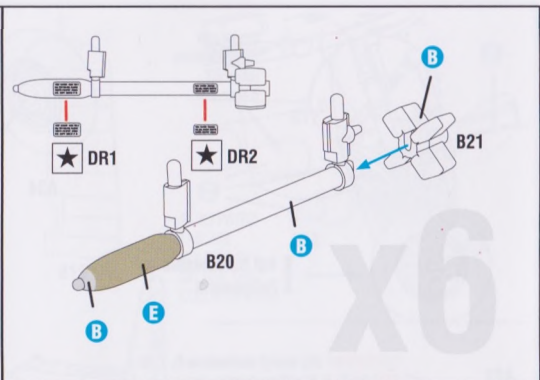
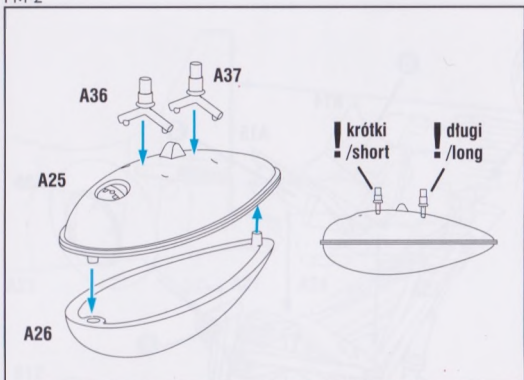

5.

ISTNIEJE PRAWDOPODOBIEŃSTWO ŻE NAZWA WŁASNA „HOT LIPS” WIDNIAŁA PO OBU STRONACH OSŁONY SILNIKA DLATEGO NA ARKUSZU ZNAJDUJĄ SIĘ DWIE KALKOMANIE. MODELARZ DECYDUJE CZY UŻYĆ OBU / THERE IS A POSSIBILITY THAT THE NAME „HOT LIPS” WAS ON BOTH SIDE OF THE PLANE, THATS WHY WE GIVE TWO DECALS. IT'S UP TO YOU IF YOU USE BOTH.

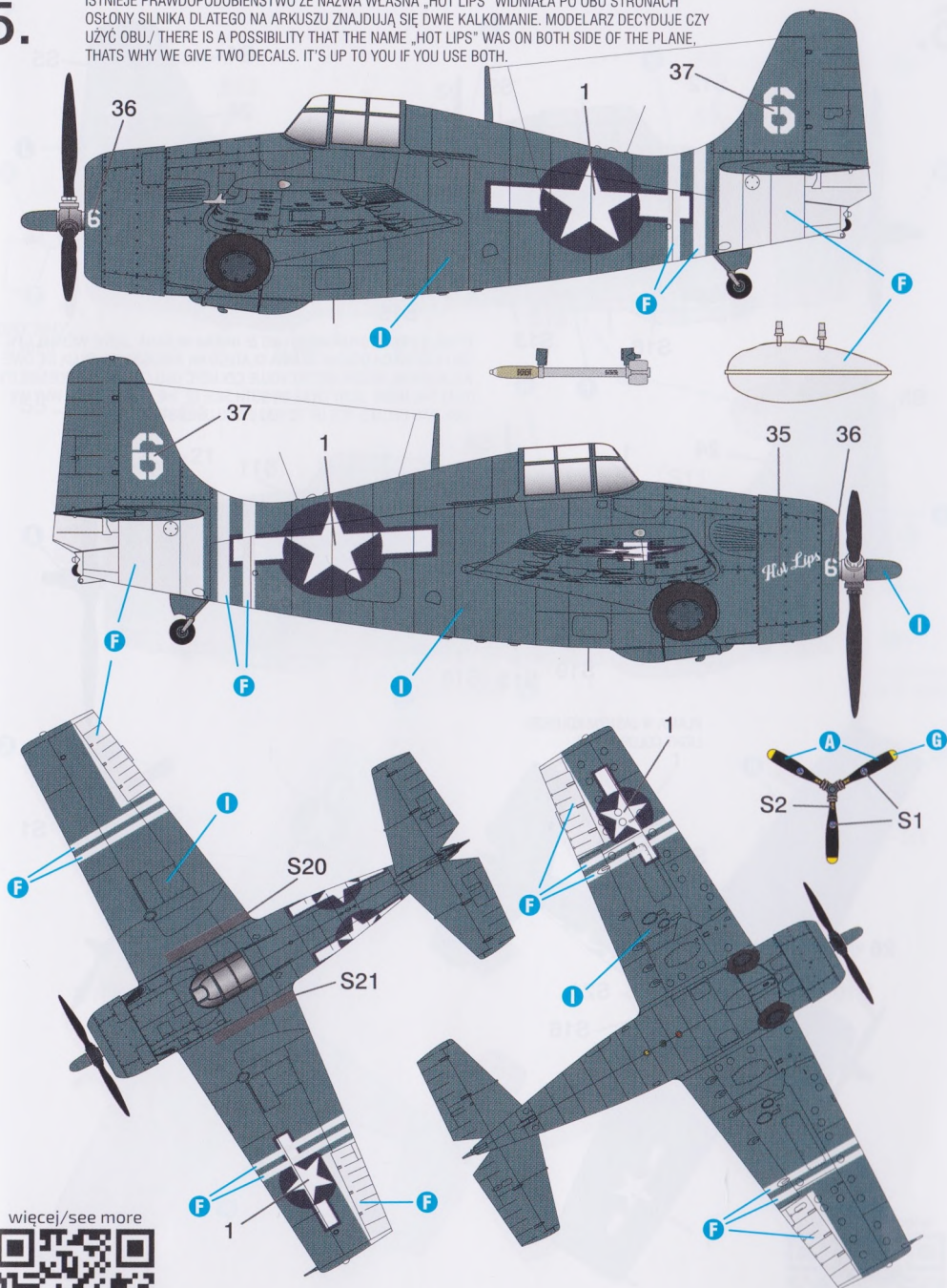

więcej/see more



<http://armahobbynews.pl/70050>

FM-2 Wildcat, nr 8, "Hot Lips", eskadra VC-99, USS Hoggatt Bay CVE-75, Pacyfik, lipiec 1945 r.

FM-2 Wildcat, no. 8, "Hot Lips", VC-99 squadron, USS Hoggatt Bay CVE-75, Pacific Ocean theatre, July 1945.

6.

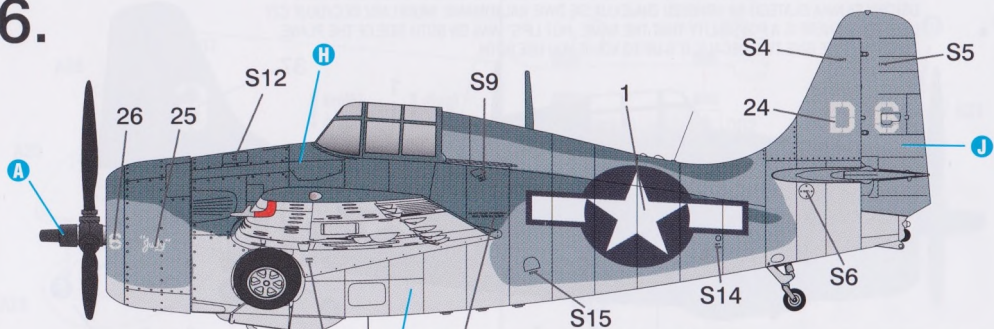

ISTNIEJE PRAWDOPODOBIEŃSTWO ŻE NAZWA WŁASNA „JUDY” WIDNIAŁA PO OBU STRONACH OSŁONY SILNIKA DLATEGO NA ARKUSZU ZNAJDUJĄ SIĘ DWIE KALKOMANIE. MODELARZ DECYDUJE CZY UŻYĆ OBU / THERE IS A POSSIBILITY THAT THE NAME „JUDY” WAS ON BOTH SIDE OF THE PLANE, THATS WHY WE GIVE TWO DECALS. IT'S UP TO YOU IF YOU USE BOTH.

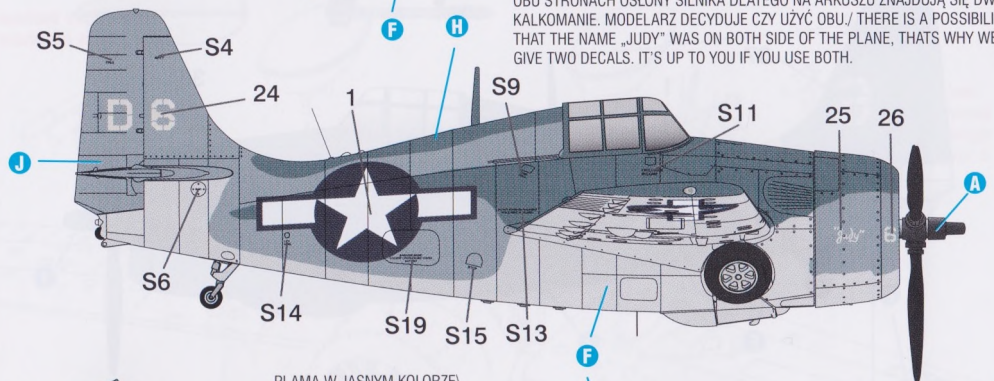

PLAMA W JASNYM KOLORZE/
LIGHT COLOR PATCH

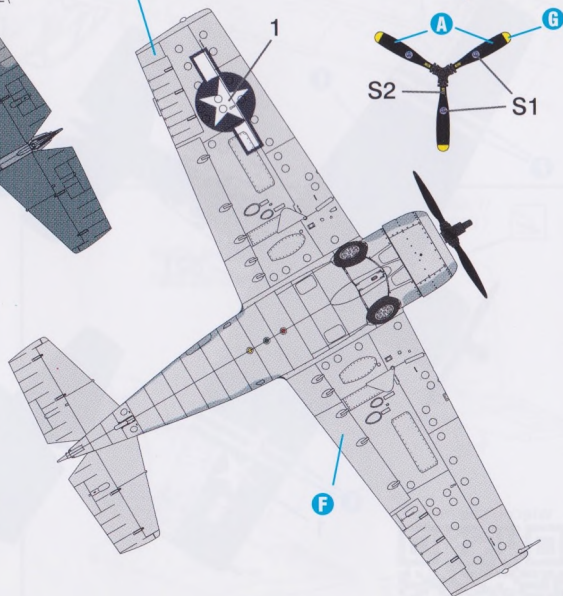
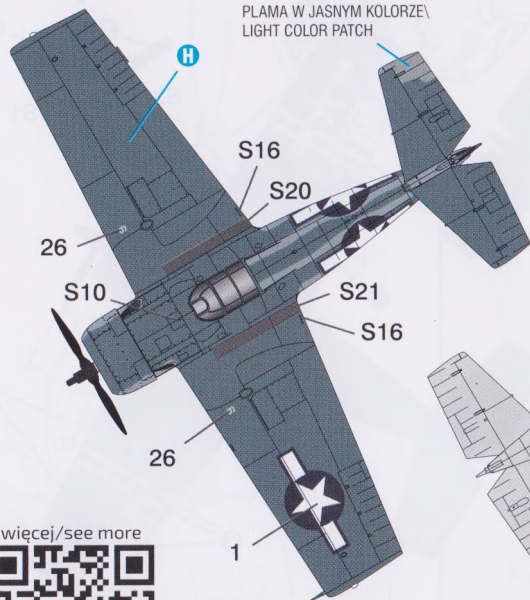

więcej/see more



<http://armahobbynews.pl/70050>

FM-2 Wildcat, nr D6, „Judy”, eskadra VC-14, USS Hoggatt Bay CVE-75, Filipiny, 22 listopada 1944 r.
FM-2 Wildcat, no. D6, „Judy”, VC-14 squadron, USS Hoggatt Bay CVE-75, the Philippines,
22 November 1944

7.

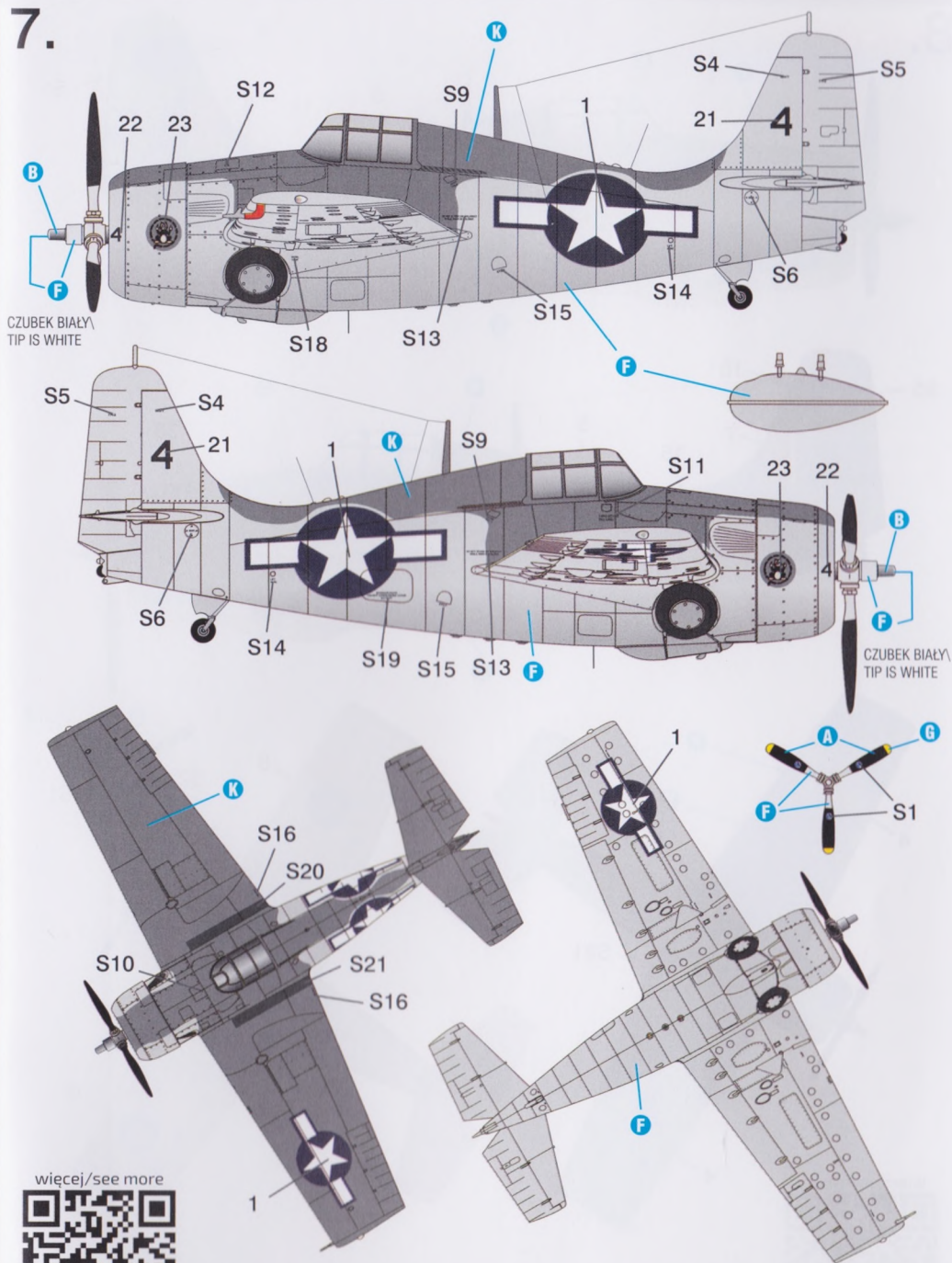

więcej/see more



<http://armahobbynews.pl/70050>

FM-2 Wildcat, nr 4, eskadra VC-13, USS Tripoli CVE-64, podczas patrolu przeciwpodwodnego na Atlantyku w rejonie Zielonego Przylądka, marzec 1944 r.

FM-2 Wildcat, no. 4, VC-13 squadron, USS Tripoli CVE-64, during anti-submarine patrols over the Atlantic in the vicinity of Cape Verde, March 1944

8.

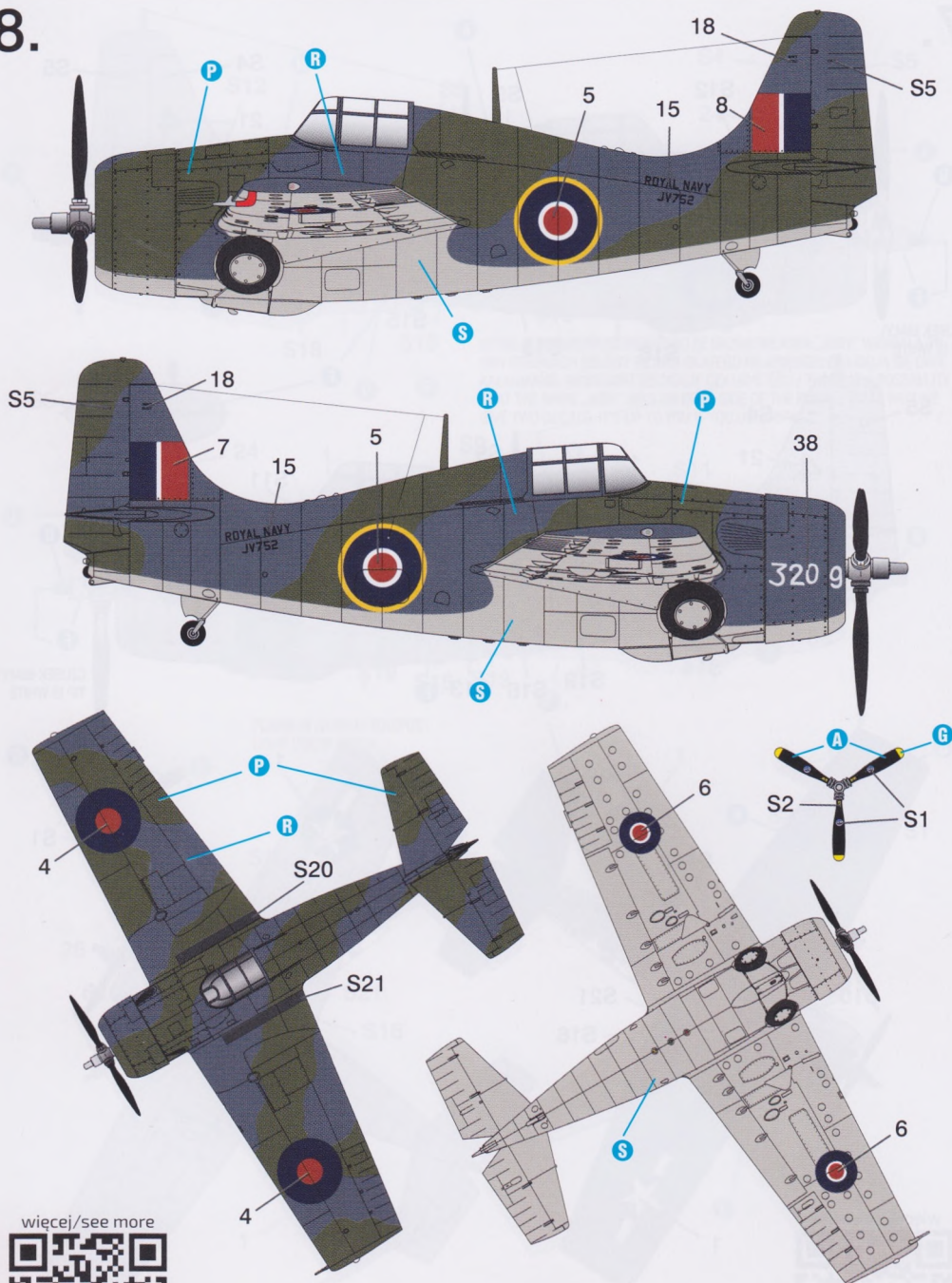

więcej/see more



<http://armahobbynews.pl/70050>

Wildcat VI, nrJV752/320-9, Aeroplane and Armament Experimental Establishment, oblatany przez S/Ldr Janusza Żurakowskiego, lotnisko Boscombe Down, 14 lutego 1945 r.

Wildcat VI, no. JV752/320-9, Aeroplane and Armament Experimental Establishment, test flown by S/L Janusz Żurkowski, Boscombe Down airfield, 14 February 1945.