

Colours & Markings

1

de Havilland DH-103 Hornet F.Mk I., PX 284, Black H, 65.squadron, airfield Linton-on-Ouse, the end of the year 1946.

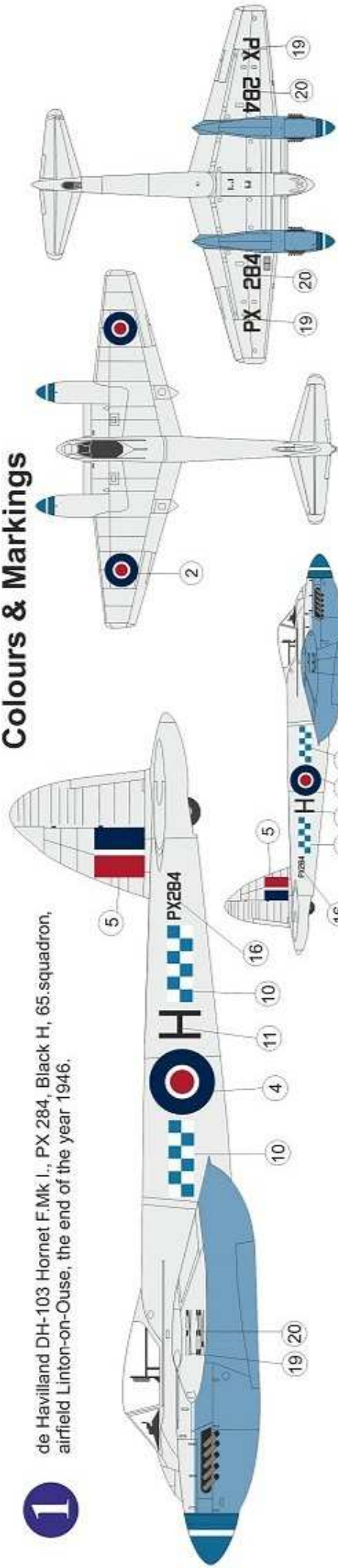

2

de Havilland DH-103 Hornet F.Mk I., PX 275, White GO-F, central Fighter Establishment, West Raynham 1947.

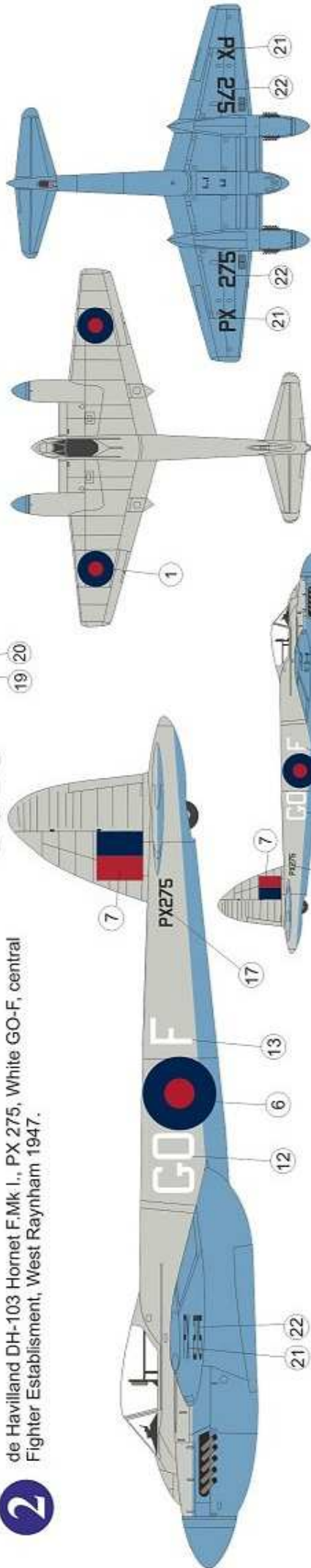

3

de Havilland DH-103 Hornet F.Mk I., PX 216, Black WA-TN, personal aircraft of Wing Commander W.A. "Tiny" Neale, Linton-on-Ouse 1947-49.

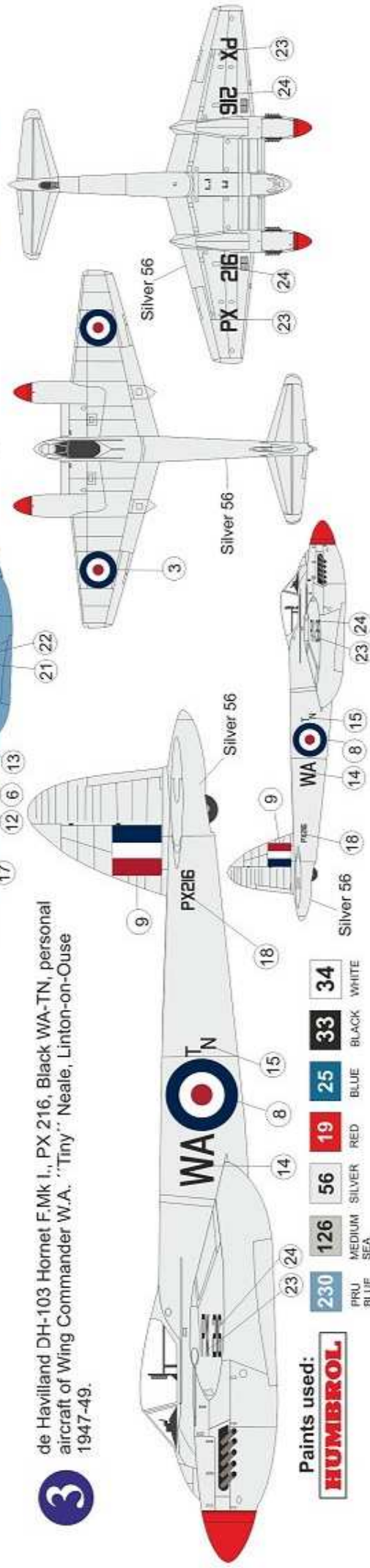

Paints used:

HUMBROL

230

PRU BLUE

126

MEDIUM SILVER

56

SILVER

19

RED

25

BLUE

33

BLACK

34

WHITE

SEA

GREY

deHavilland DH 103 Hornet

History in brief

The de Havilland DH.103 Hornet, developed by de Havilland, was a fighter aircraft driven by two piston engines. It further exploited the wooden construction techniques that had been pioneered by the de Havilland Mosquito. Development of the Hornet had started during the Second World War as a private venture. The aircraft was to conduct long range fighter operations in the Pacific Theatre against the Empire of Japan but the war ended before the Hornet reached operational squadron status.

The Hornet entered service with RAF Fighter Command where it equipped several day fighter units and was commonly stationed in the British mainland. It saw combat in the Far East, being used as a strike fighter as part of the British military action taken during the Malayan Emergency. A naval carrier-capable version, the Sea Hornet, had been envisioned early on and was procured by the Fleet Air Arm of the Royal Navy.

Producers' thanks go to Tony Buttler (Warpaint author), Richard Franks (Valiant book author), David Collins, Martin Derry (Dalrymple & Verdun book authors), David Askett for their great works we have used during the designing the kit and to our Britmodeller fellows who provided us the contacts to proper persons.

Read before you start:

- 1/ Before you begin, study carefully instructions, exploded drawings and numbering of parts.
- 2/ Prior your assembly, choose carefully your variant and remove all parts of it.
- 3/ Optional parts and theirs application compare with the picture on the box.
- 4/ Carefully remove parts, clean its and prior to applying adhesive, check to see whether the parts fit together.
- 5/ Assemble thoroughly, do not hurry. You will find that your finished model will reflect your time, work and patience.

Doporučení a upozornění:

- 1/ Dříve než začnete ,prostudujte stavební návod a číslování dílů.
- 2/ Před začátkem stavby zvolte verzi a pečlivě vyberte díly pro variantu, kterou chcete stavět .
- 3/ Volitelné díly/možnosti a jejich použití při stavbě konfrontujte s náhledem markingu na obalu.
- 4/ Díly opatrně oddělte z rámečků, odstraňte technologické vtoky a před slepením je řádně začistěte.
- 5/ Pracujte pečlivě, nespěchejte, dokonalý vzhled modelu záleží jen na Vás.

Symbols/Symboly

Drill hole



Vyvrtat

Cyanoacrylate



Vteřinové lepidlo

Remove



Odstranit

Reduce



Zbrousit

Make new



Vyrobít

Option



Volba

Bend



Ohnout

Putty



Tmel

	Colour name	Humbrol		Colour name	Humbrol
A	Black	H33	F	Aluminium	H56
B	White	H34	G	Dark Green	H30
C	Interior Green	H78	H	Yellow	H24
D	Gunmetal	H53	I	Tyre	H85
E	Leather	H62	J	Rust	H113

Drawings/Výkresy:
Internet

References/Podklady
Internet

Plastic parts

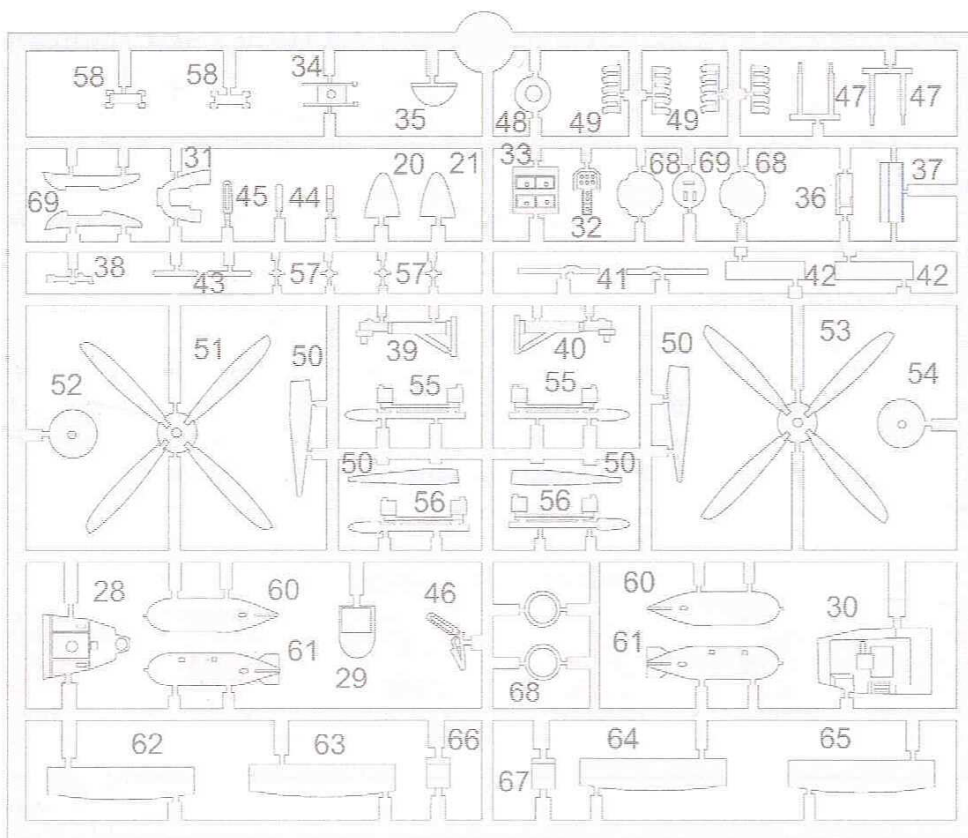
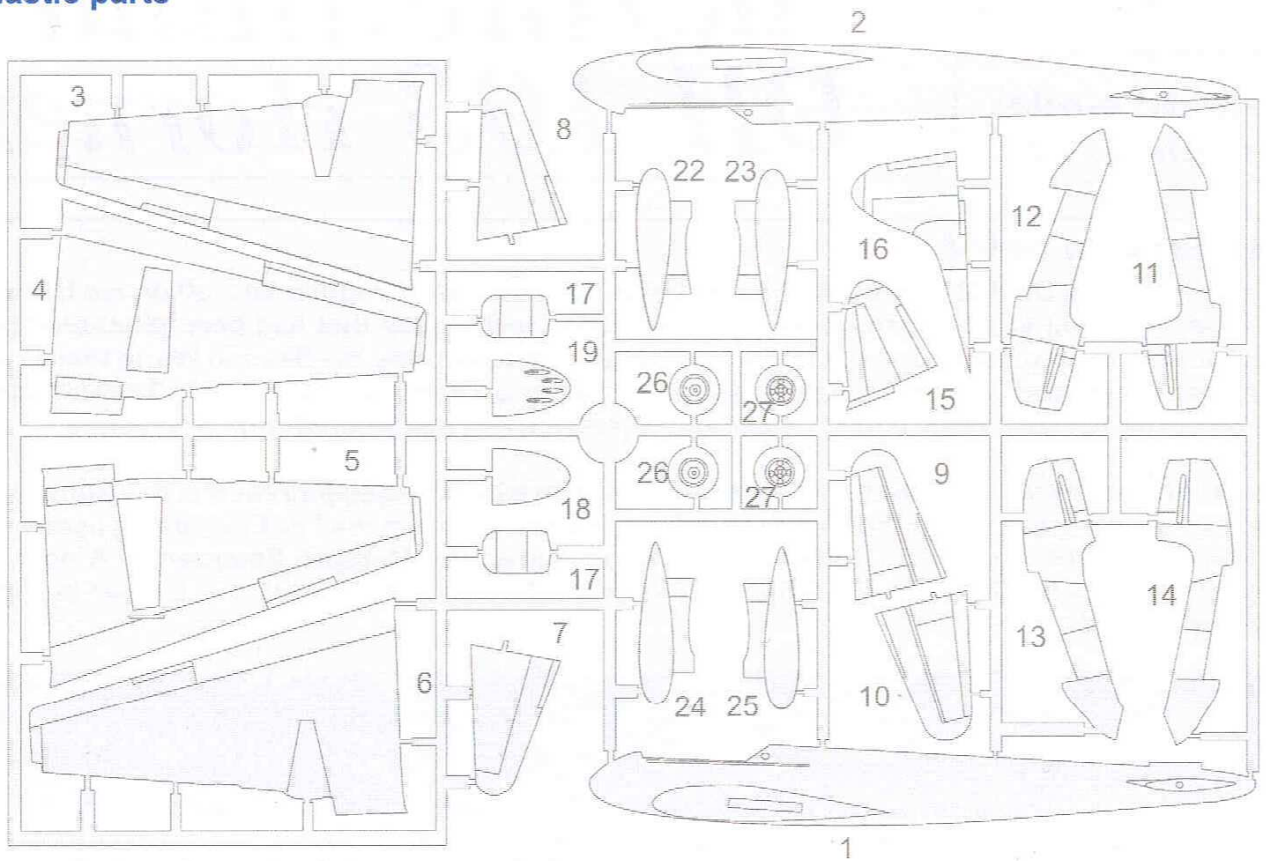

Transparent parts

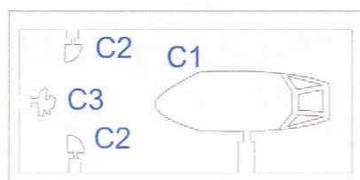

1

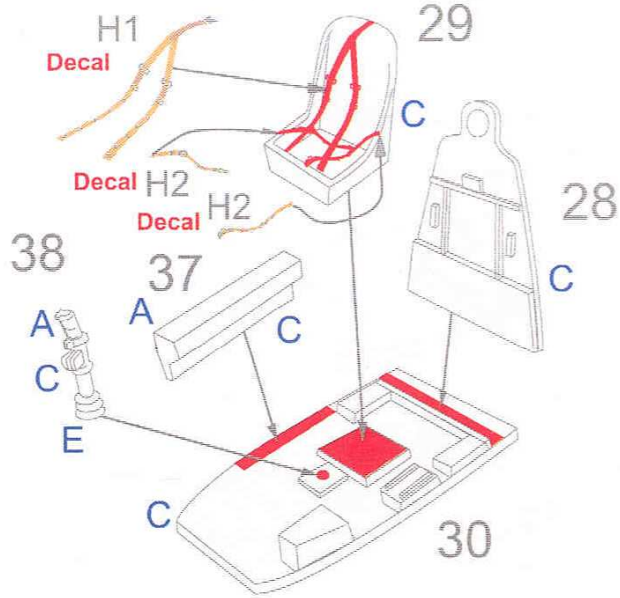

2

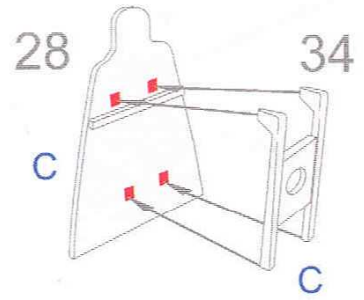

3

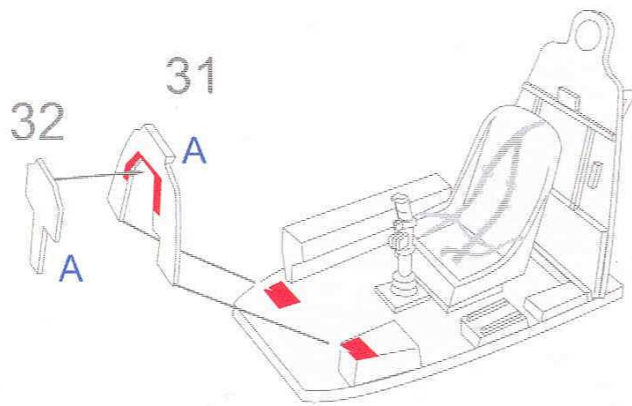

paper panel

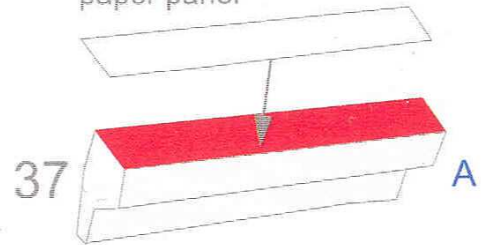

size 1:1



4

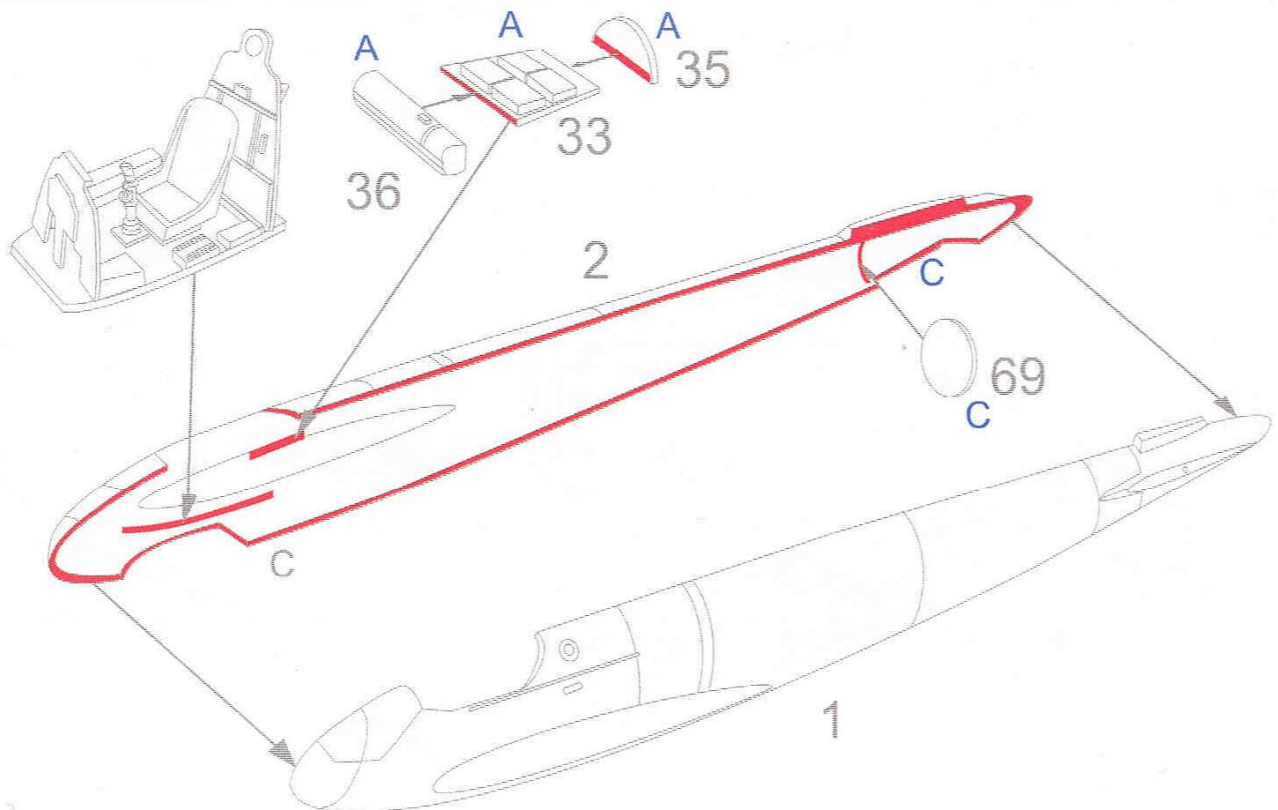

5

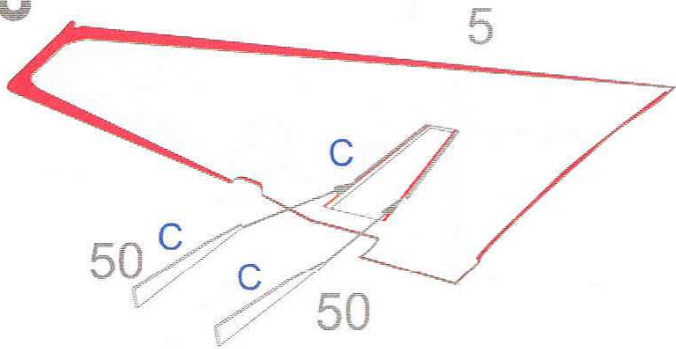

6

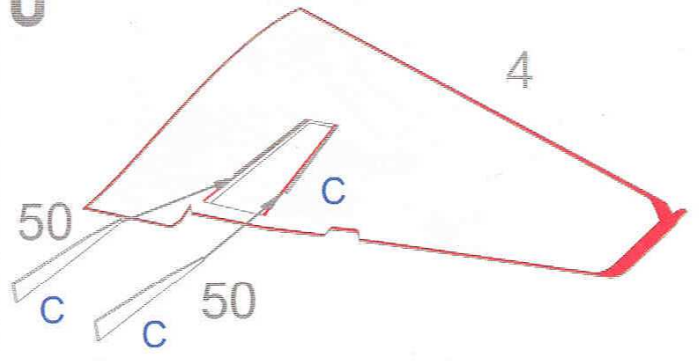

7

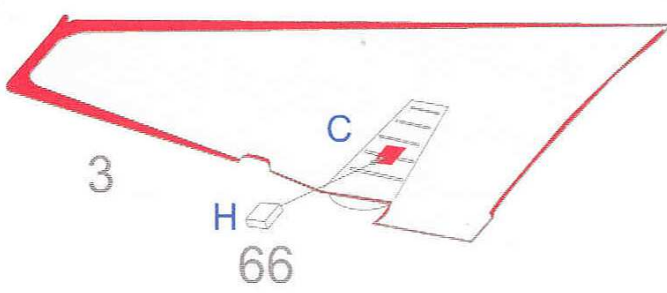

8

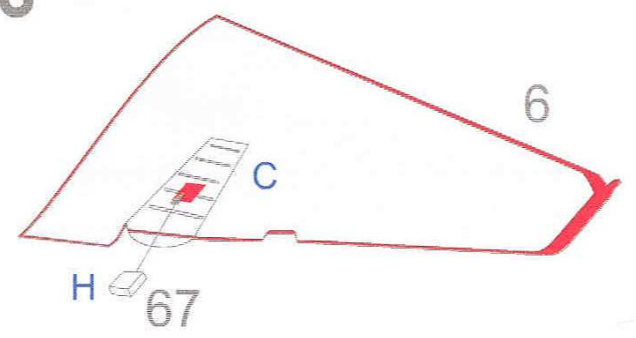

9

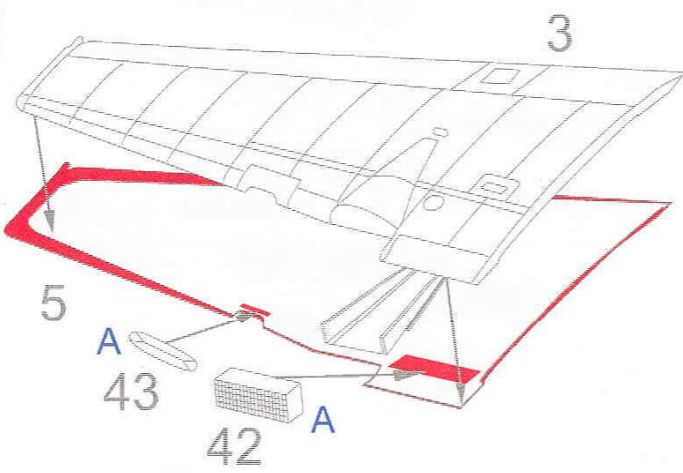

10

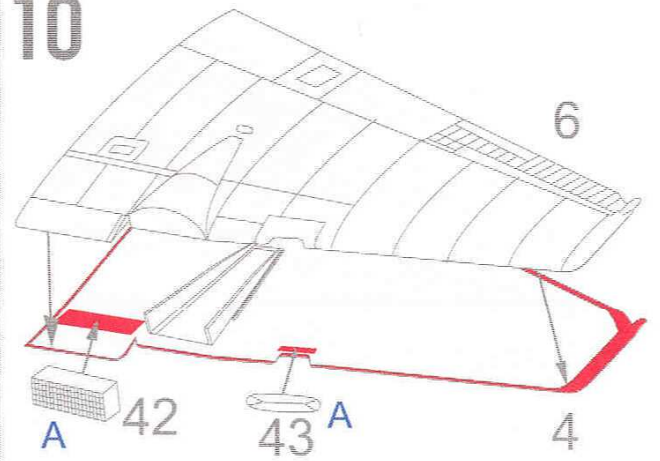

11

left side

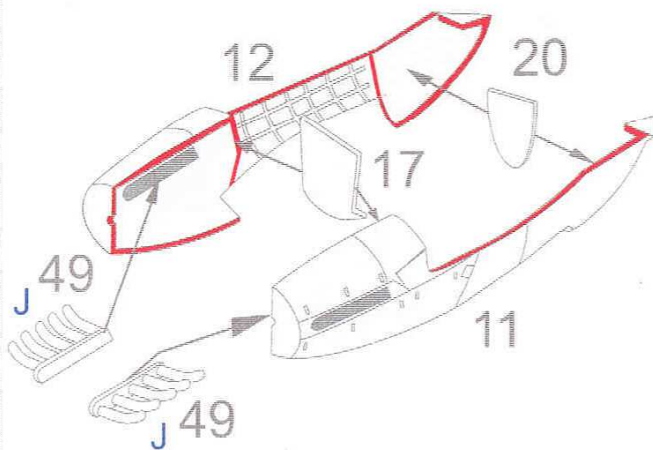

12

right side

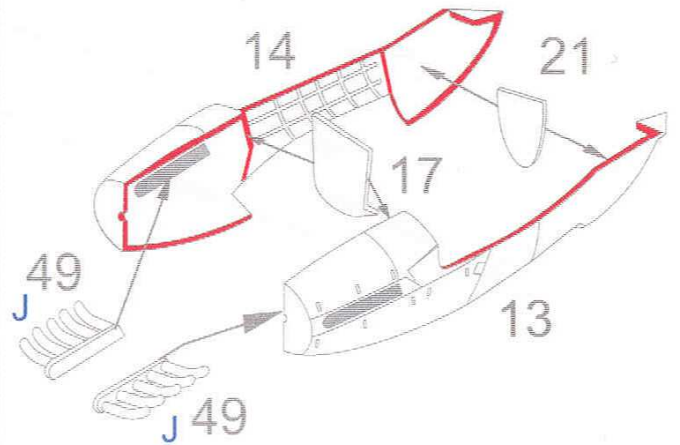

13

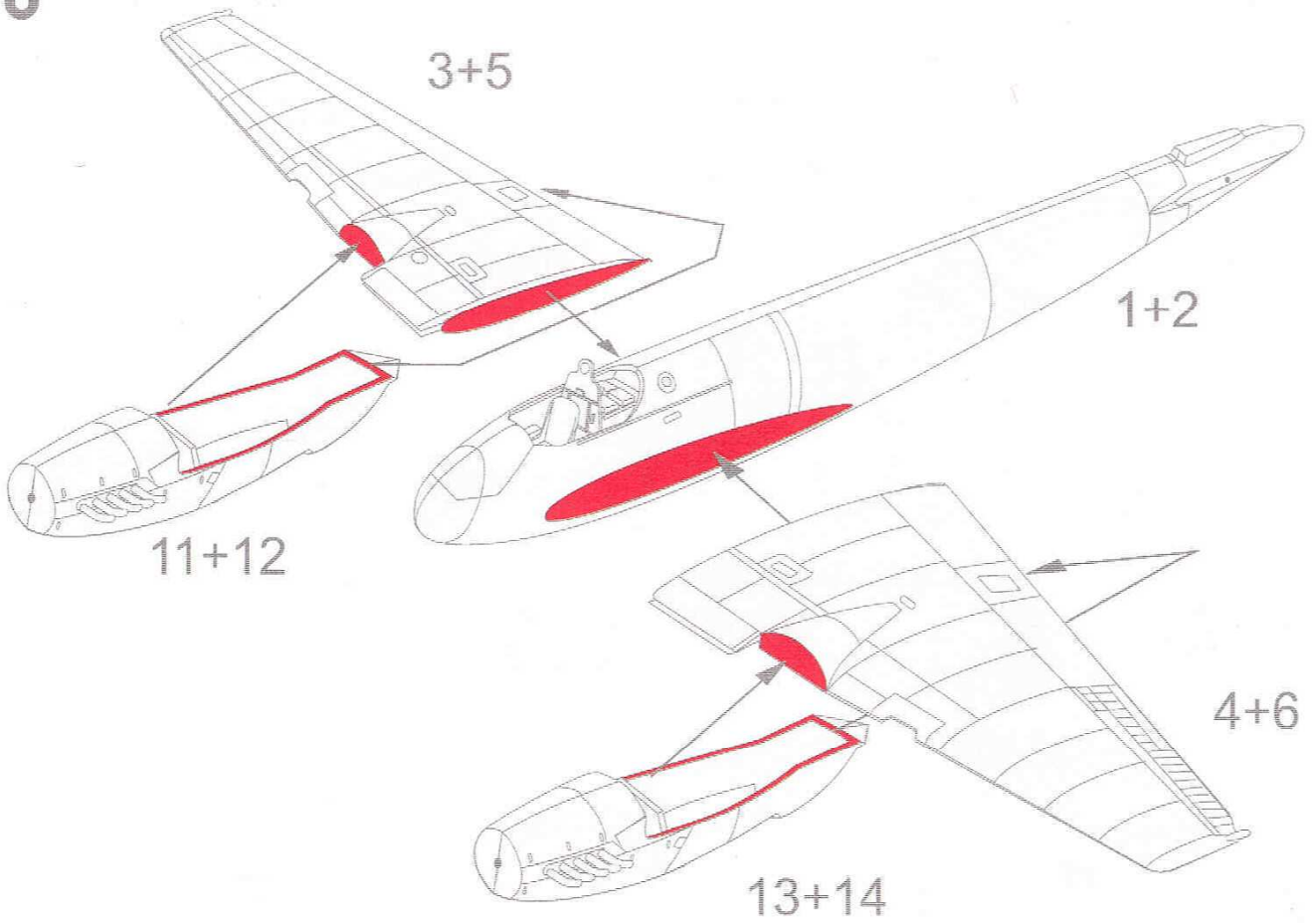

14

For PR version only

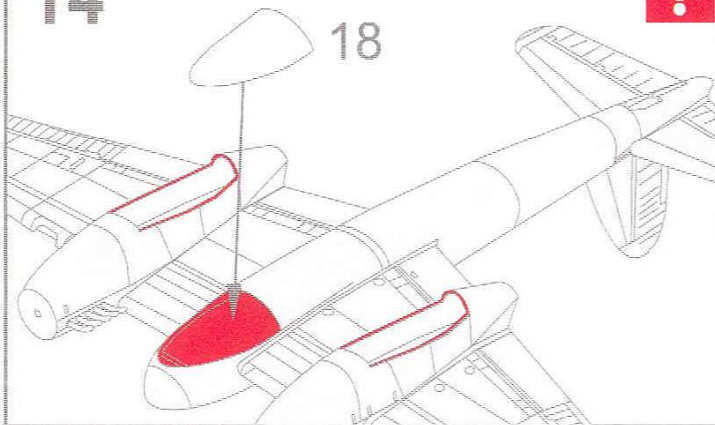

15

For Mk. 1, 3, 4 versions only

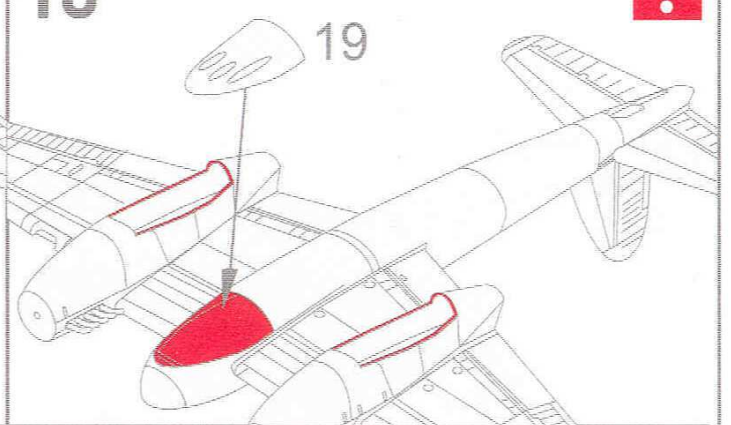

For Mk. 1, 2 versions only

16

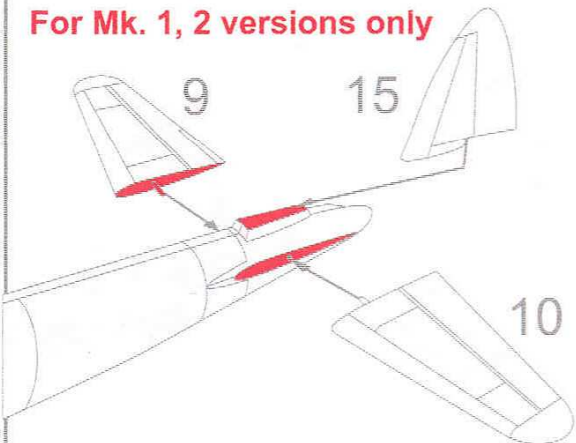

For Mk. 3,4 versions only

17

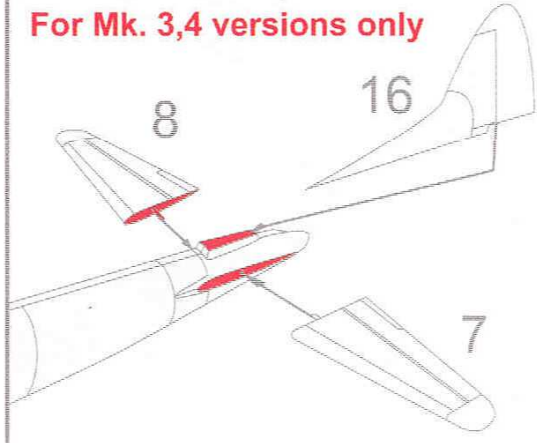

18

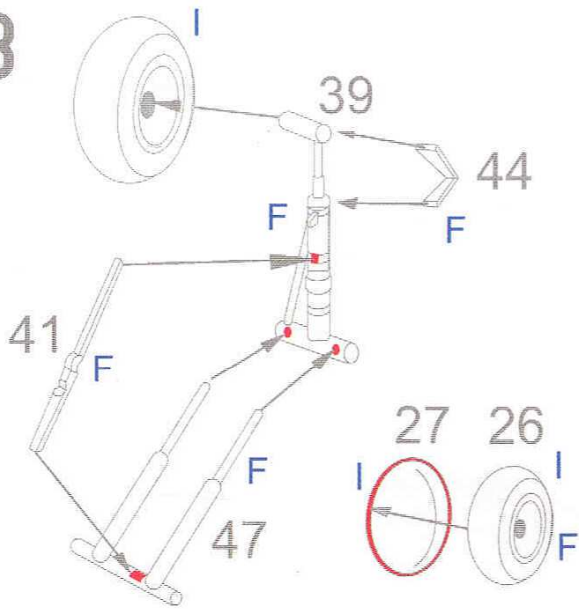

19

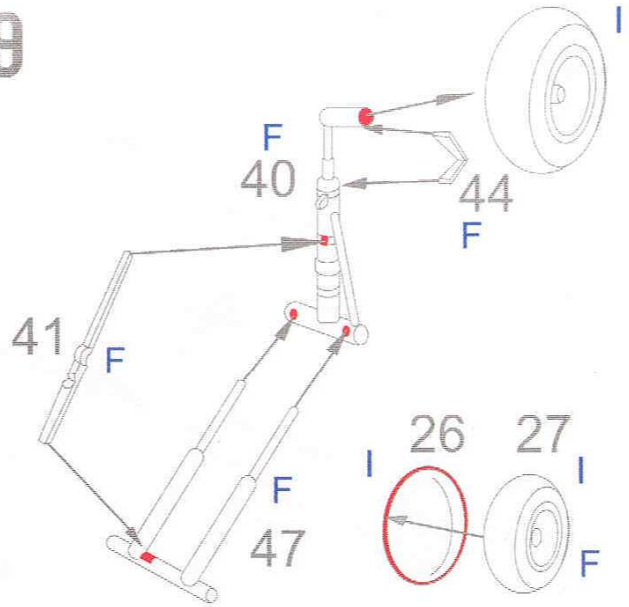

20 (A)

left side

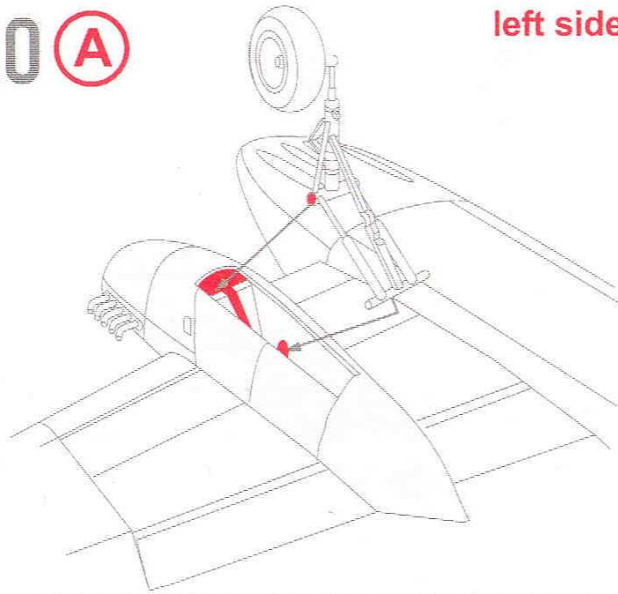

21 (B)

right side

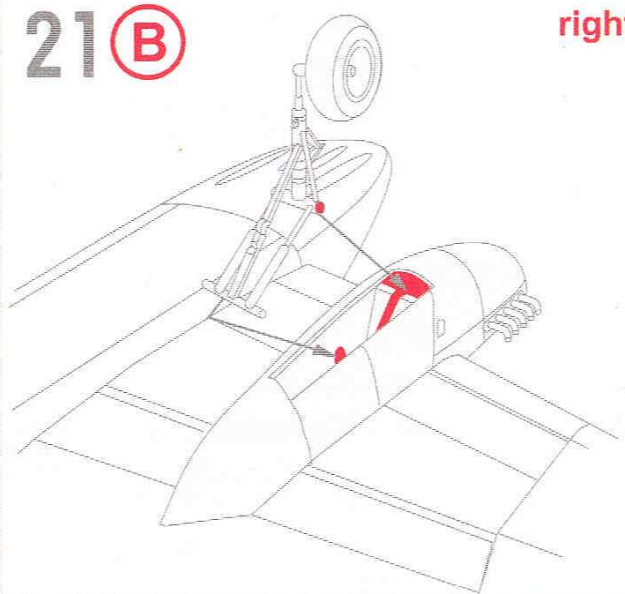

22

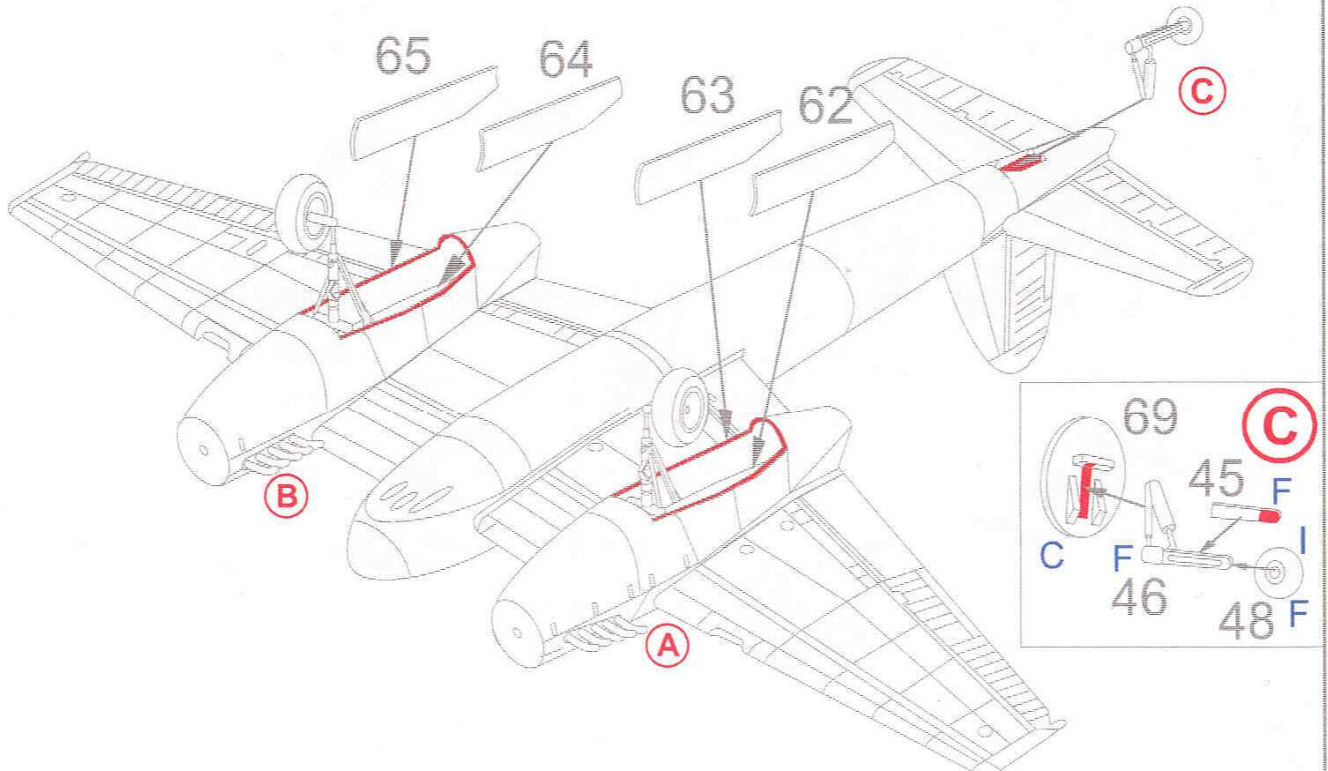

23

left side

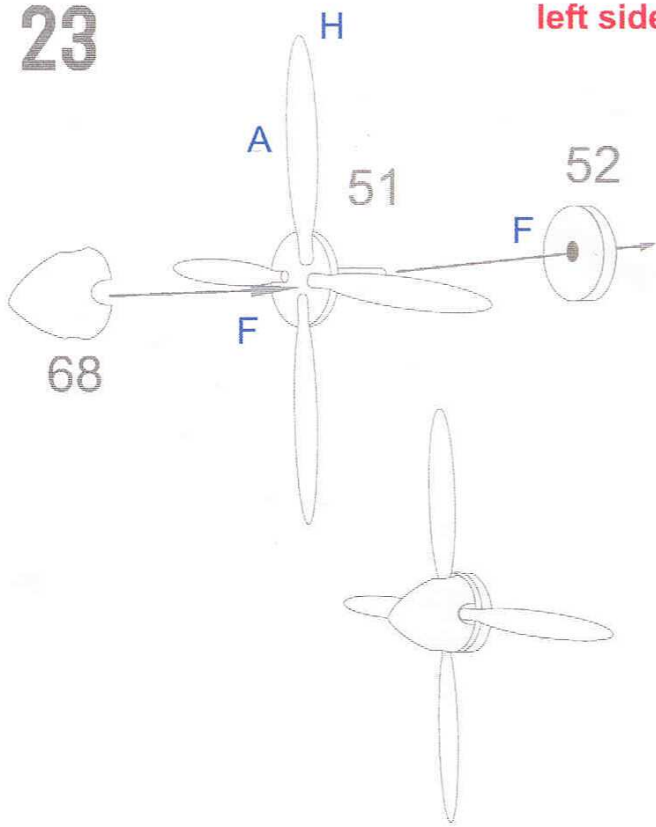

24

right side

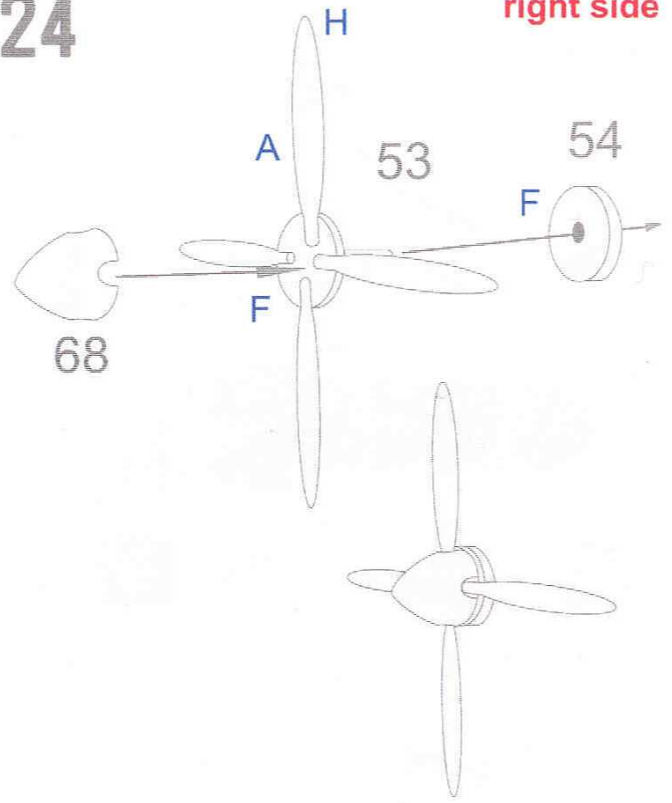

25

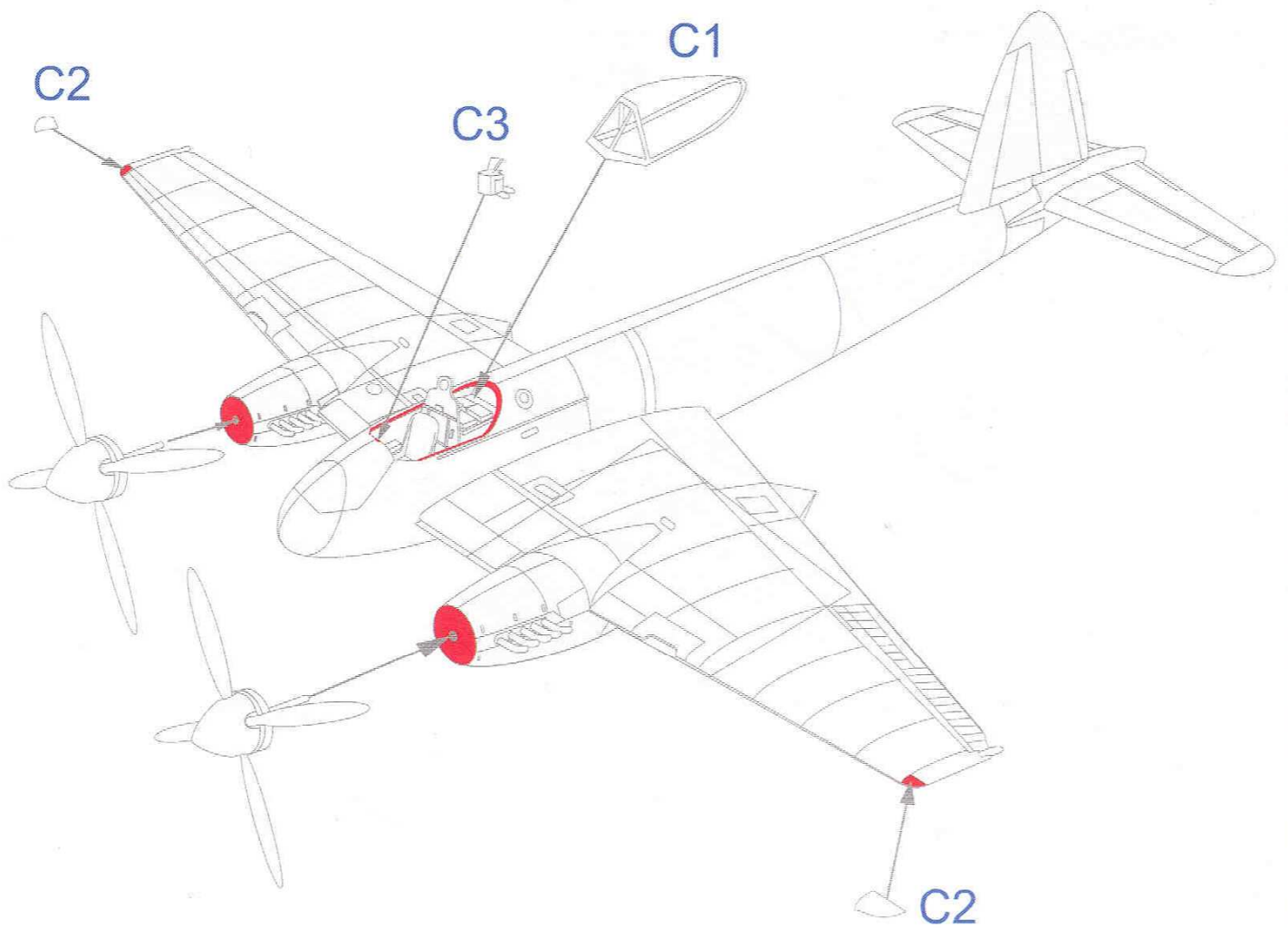

26

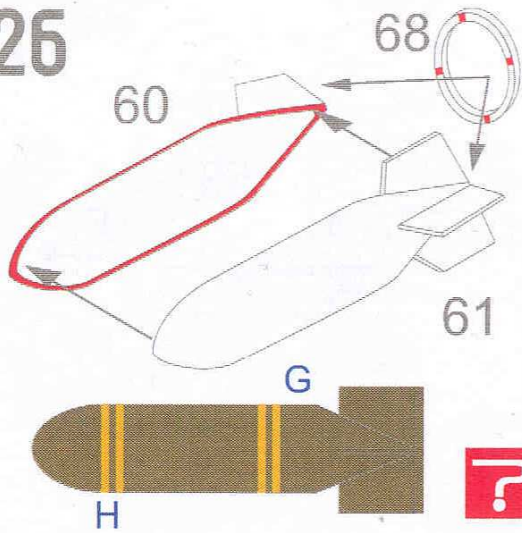

27

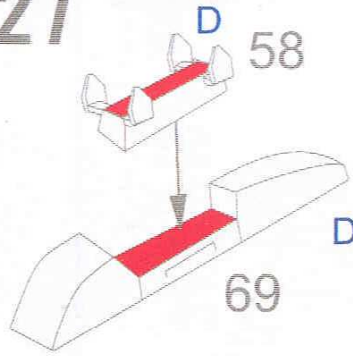

28

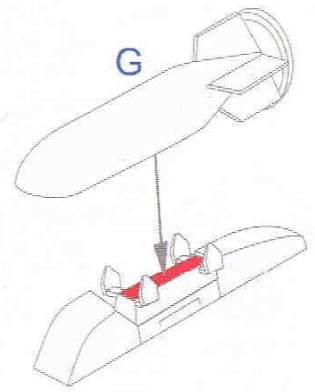

29

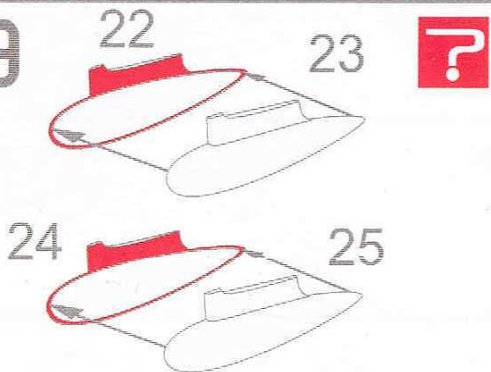

30

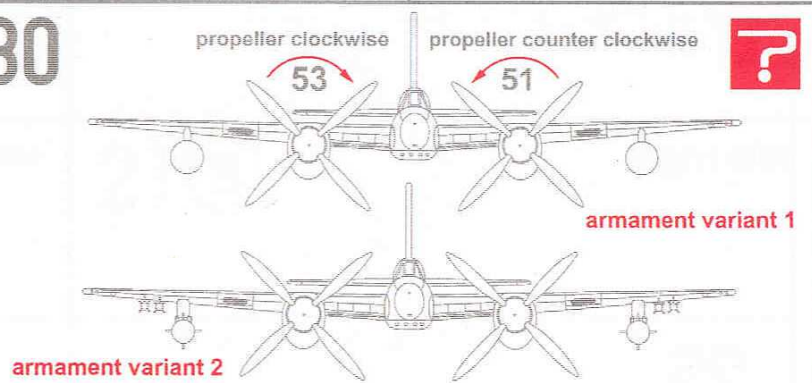

31

