

Reggiane Re 2005 Sagittario

SW 72031 scale: 1/72

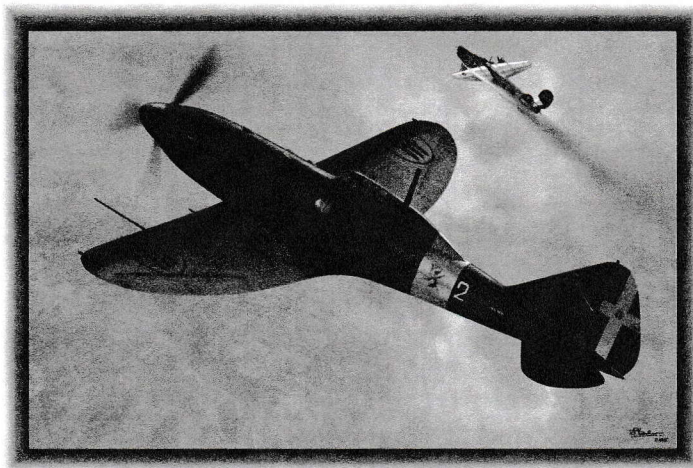

The Reggiane Re 2005 is considered by many as "the most beautiful fighter of the axis". In fact, the Sagittario was a really beautiful airplane, with a clean and fascinating shape, but also had exceptional flying characteristics, powerful armament and exceptional handling.

It was the plane limited by a slow production during the war, also due to the American bombing runs over the Reggiane factory.

The Reggiane Re 2005 Sagittario was the final result of a series of fighters which started with the Re 2000 Falco I and continued with the Re 2001 Ariete I and Re 2002 Ariete II. The Reggiane team led by Ing. Alessio and Ing. Longhi devoted itself with much resolve to the realization of the new fighter and the result was of great excellence. The construction of the first prototype was started in October 1941 and completed at the end of 1942. After the first flights the prototype was sent to the Experimental Air Force Centre of Guidonia, where some modifications were requested and the Re 2005 proved to have better performance than the others Italian fighters, with a maximum speed of 678 km/h at 2000m. The Air Force ordered 750 Reggiane, but only few were produced.

In May of 1943, the first Sagittarios entered service with the Regia Aeronautica. The first prototype and several aircraft were used operationally by the 362 Squadriglia, 22o Gruppo at Naples-Capodichino starting in May 1943, being used to defend Rome and Naples. Sagittario was not fighting a long time, Armistice, that came in the September 1943, stopped the war in Italy.

Luftwaffe has tested also Re-2005 (with German engine DB605A and a VDM propeller) but good results. Some of the Sagittarios were reengined by the Germans with DB605As and equipped with VDM props after the Armistice, before being flown to an uncertain fate in Germany.

Specification

Engine: Fiat RA.1050 RC 58 Tifone 12-cylinder inverted Vee

Span: 36 ft 1 in / 11 m. Length: 28 ft 7 3/4 in / 8.73 m.

Max Speed: 6,560 ft / 2,000 m: 421 mph / 678 kph

Ceiling: 37,730 ft / 11,500 m

Range: 609 miles / 980 km.

Armament: 20mm MG Two 12.7 mm Breda-SAFAT machine guns with 350 rounds each in upper engine cowling.

One 20 mm Mauser MG 151 cannon with 150 rounds firing through propeller hub.

Two 20 mm Mauser MG 151 cannon with 200 rounds each in wings.

Up to 2,200 lb / 1,000 kg bomb or fuel tank under fuselage.

Two wing hardpoints for 353 lb / 160 kg of bombs or fuel tanks.

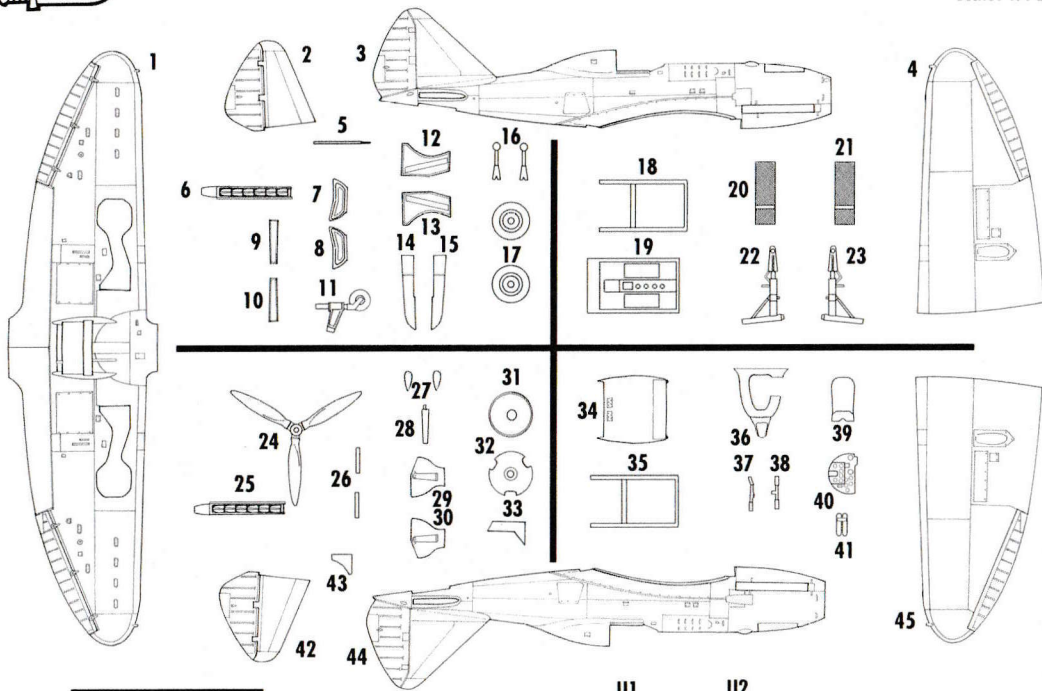

CLEAR
 C1
 C2

URETHAN
 U1
 U2
 U3

BARVA/COLOR	
A	Vnitřní zelená Interior Green
B	Černá/Black
C	Stříbrná/Silver
D	Hliníková Aluminium
E	Chromová Chrome
F	Dřevo/Wood
G	Rezavá/Rust
H	Bronzová Bronze
I	Kovová Gun metal
J	Barva pneu Tyres Black
K	Střední šedá Medium Grey
L	Tmavá šedá Dark Grey

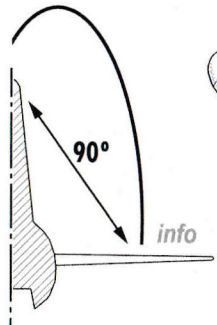
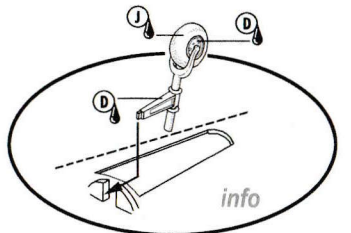
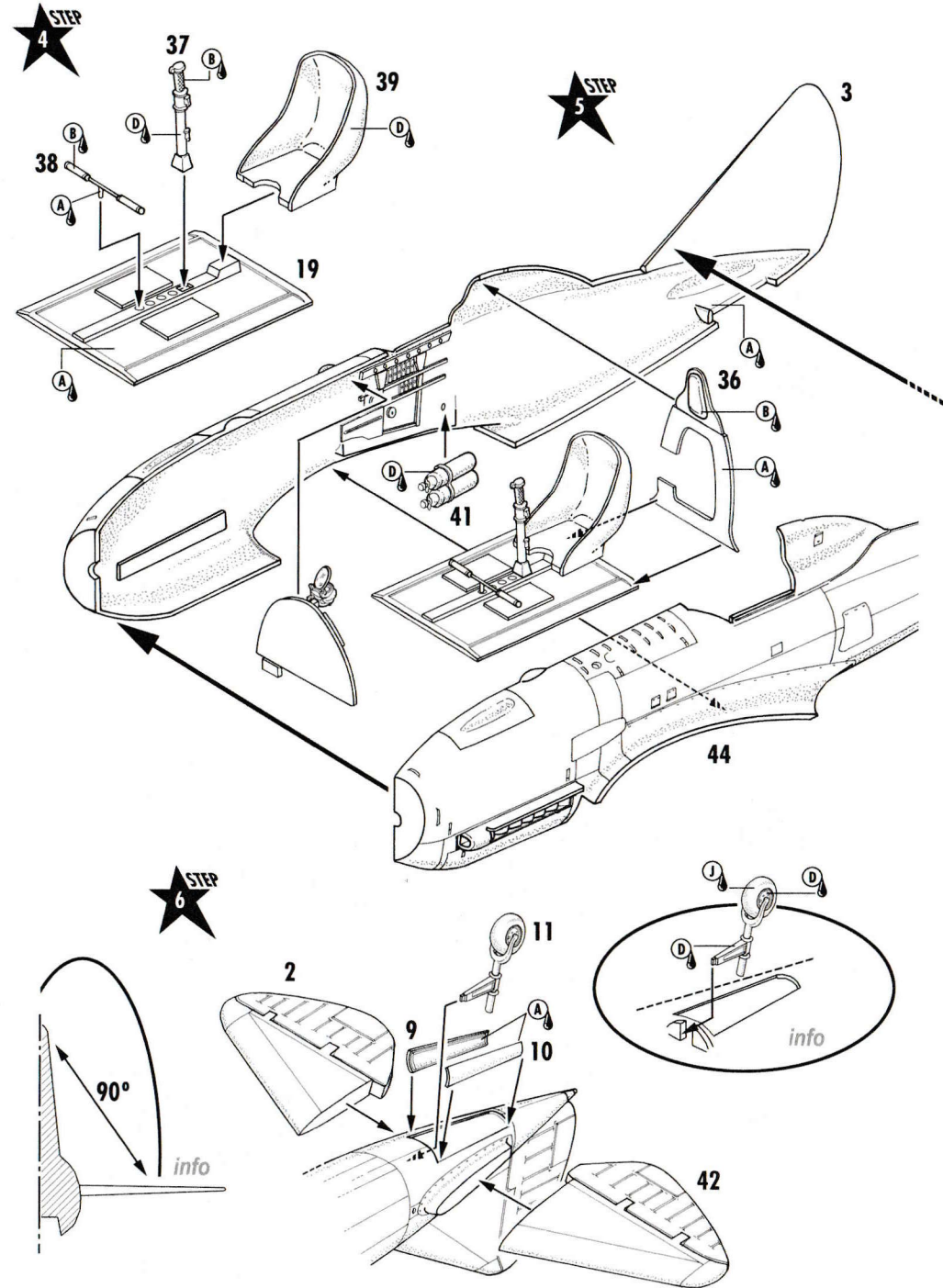
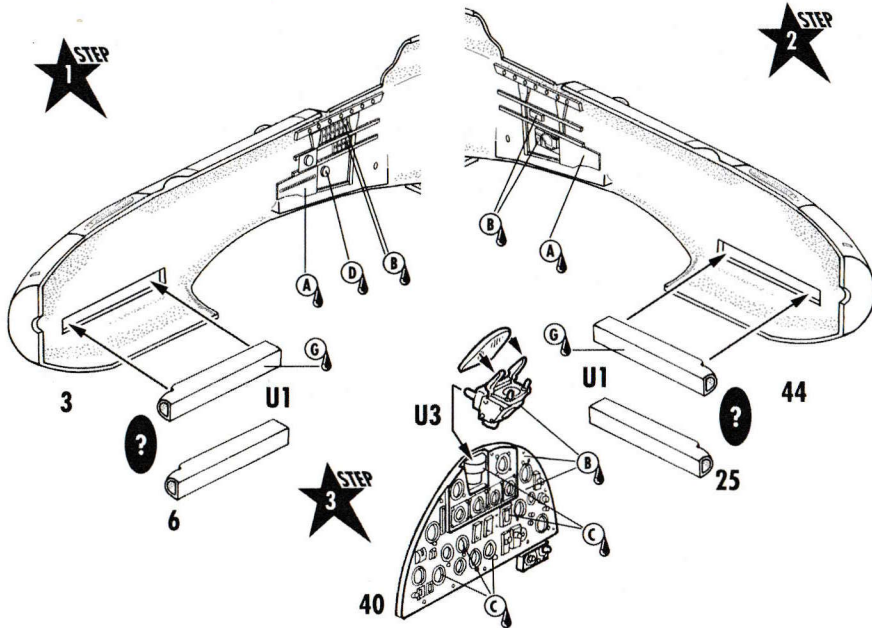

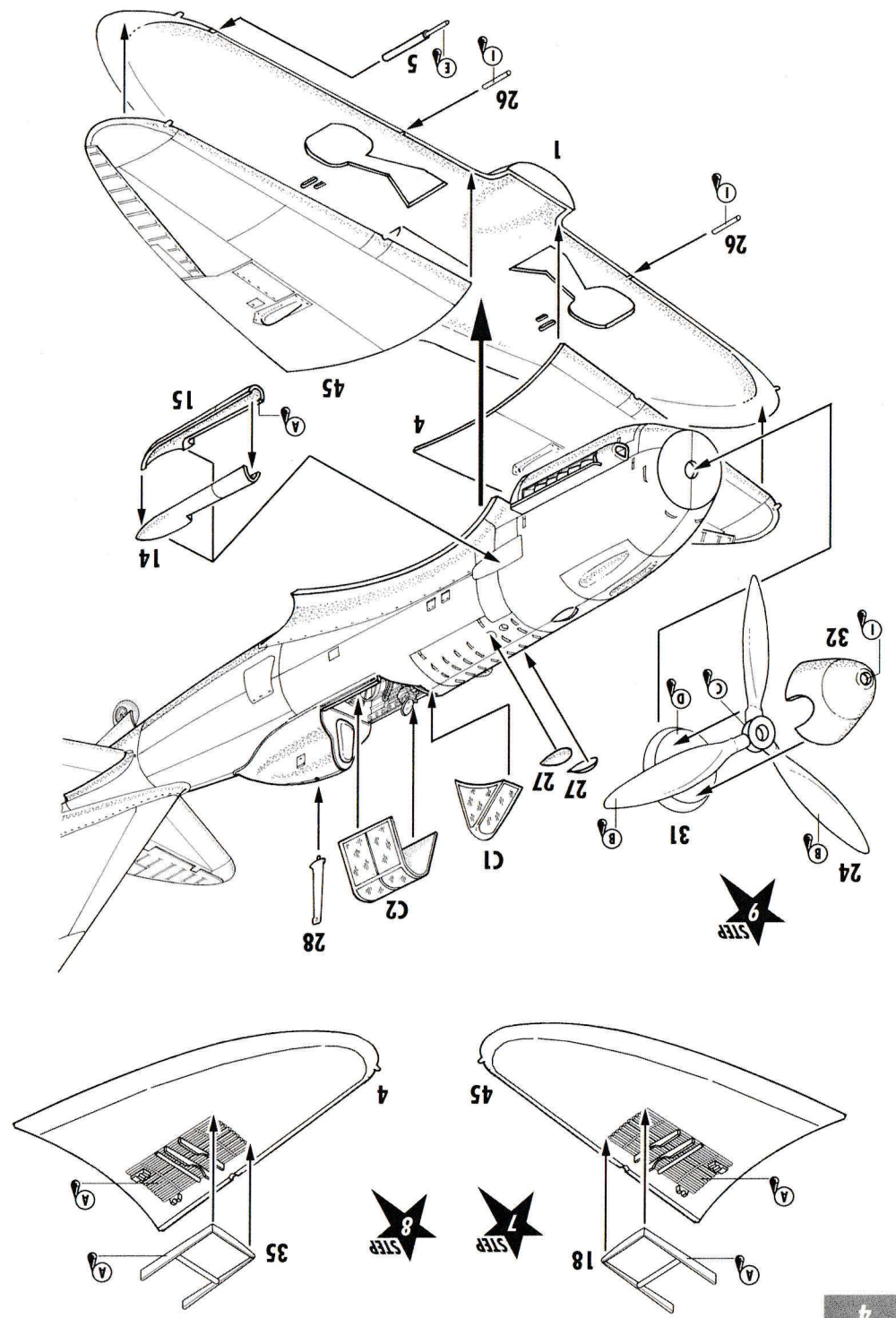
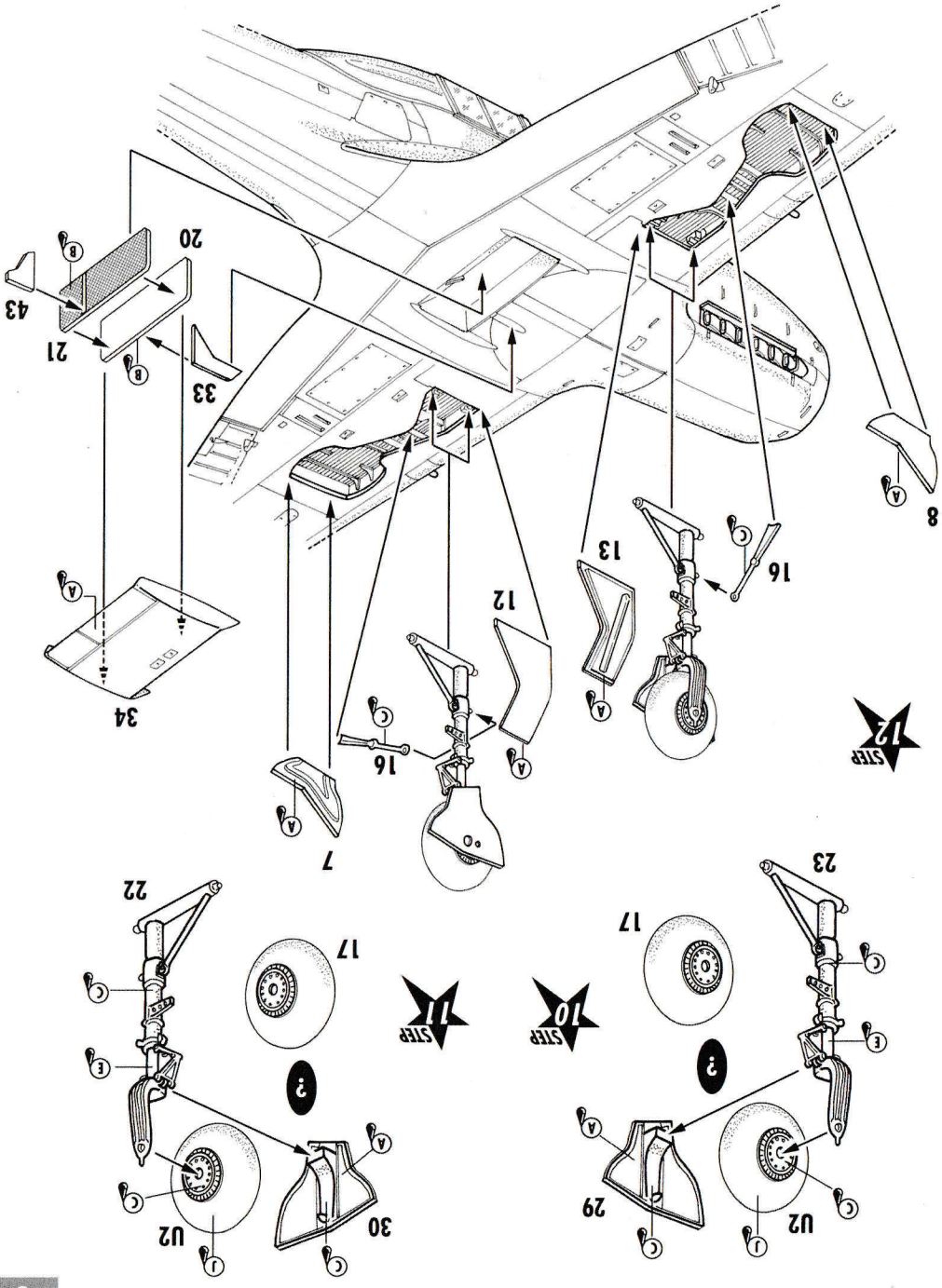

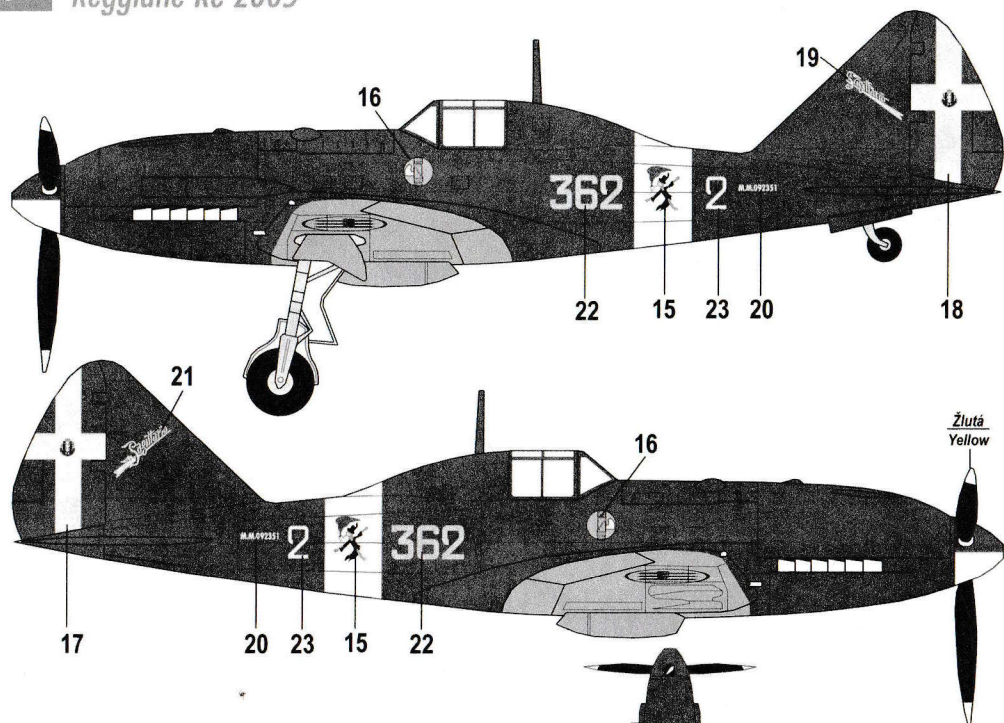

Reggiane Re 2005
M.M.092351, 22nd fighter group,
Capua summer 1943

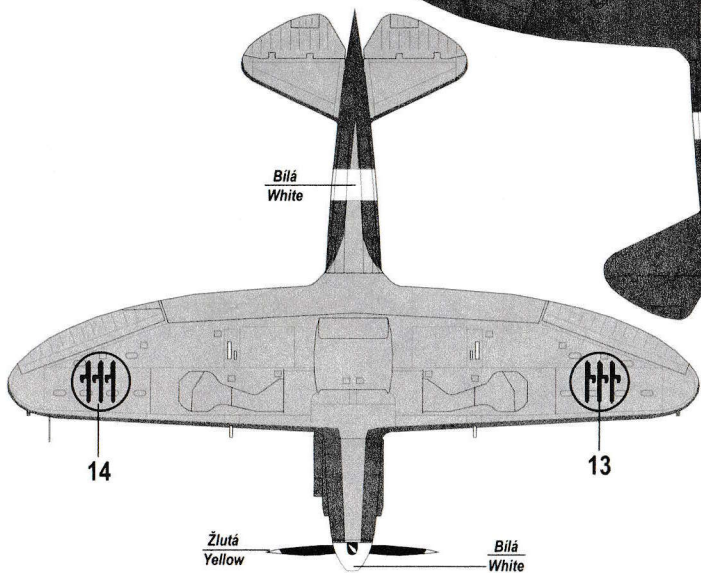
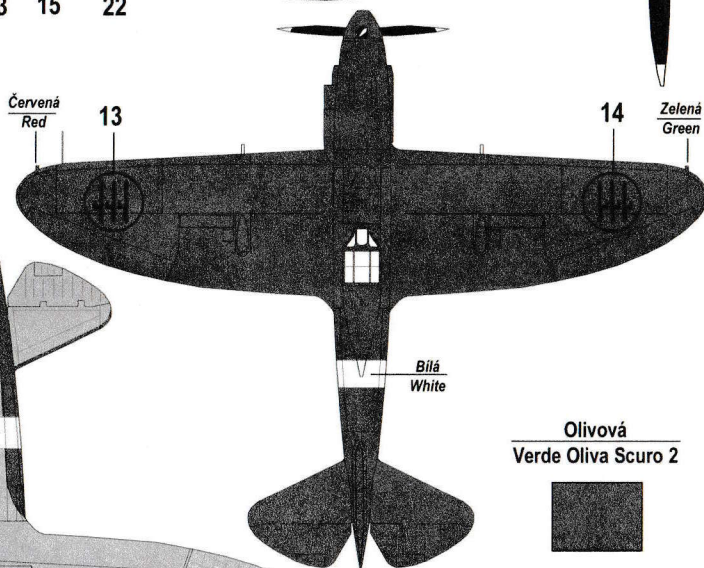

Olivová
Verde Oliva Scuro 2



Světle šedá
Grigio Azzurro Chiaro

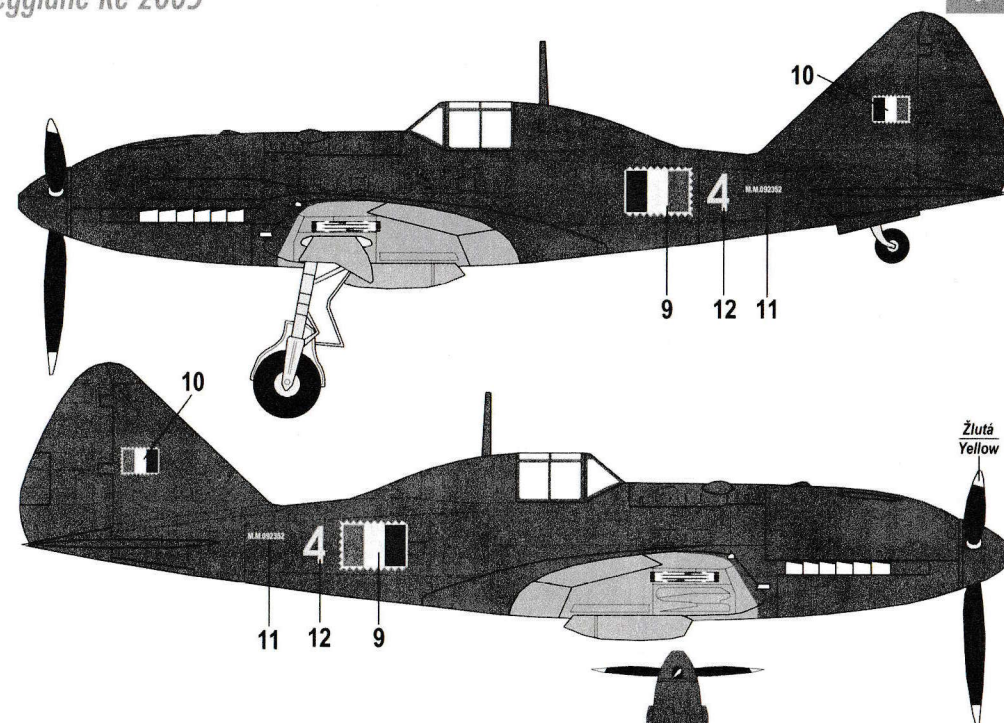

Reggiane Re 2005
M.M.092352 Aeronautica Repubblicana,
Bresso March 1944

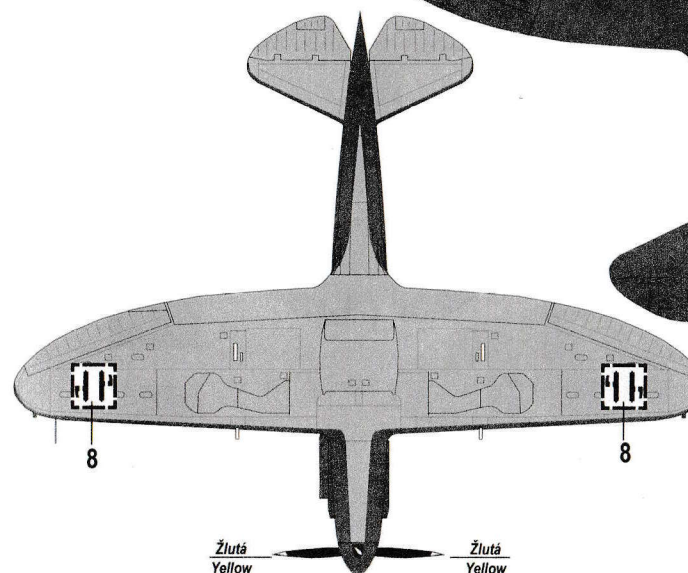
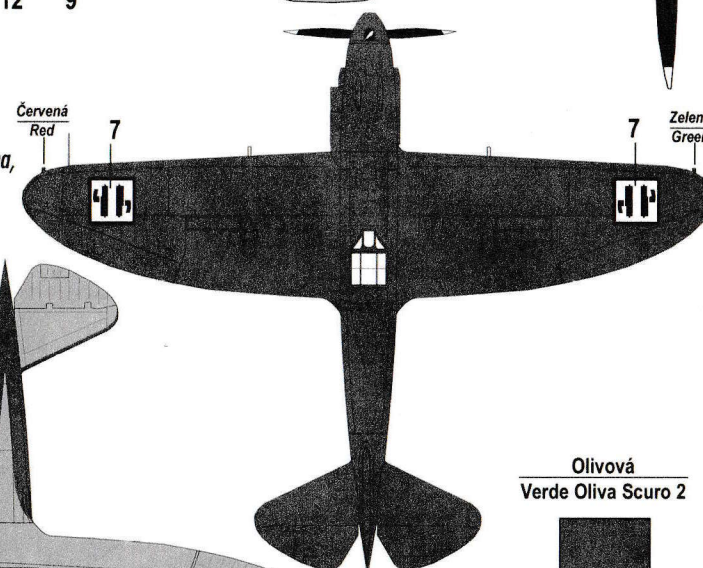

Olivová
Verde Oliva Scuro 2



Světle šedá
Grigio Azzurro Chiaro

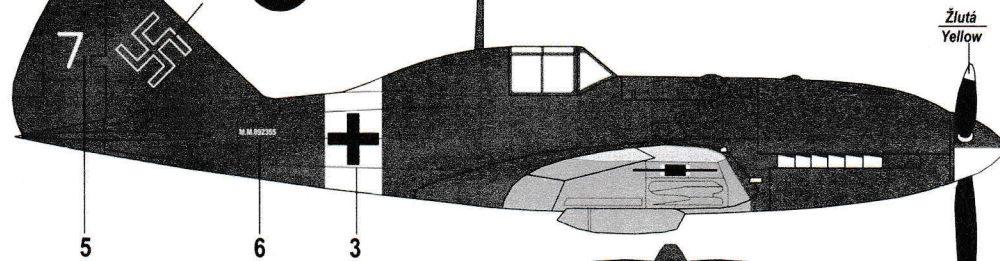
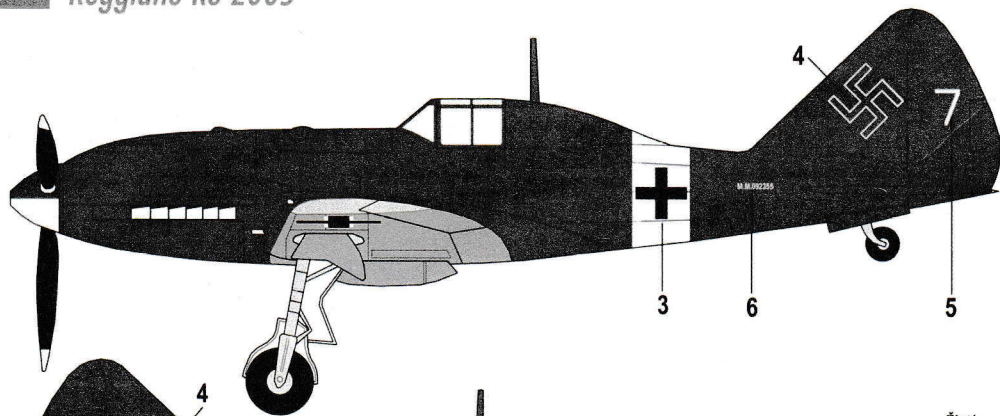

Reggiane Re 2005
one of 12 Luftwaffe Re 2005,
Reich's Defence 1944

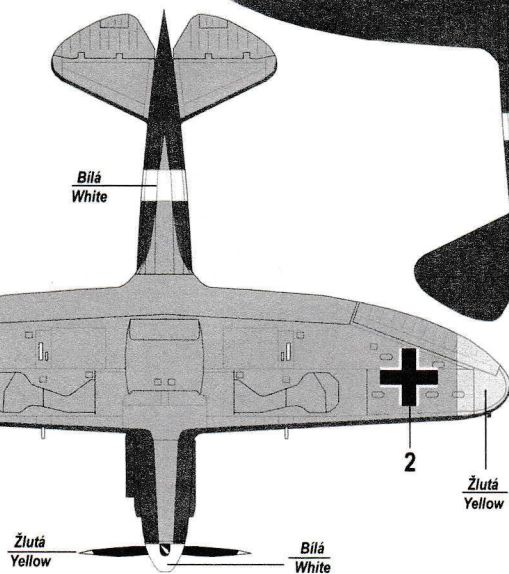
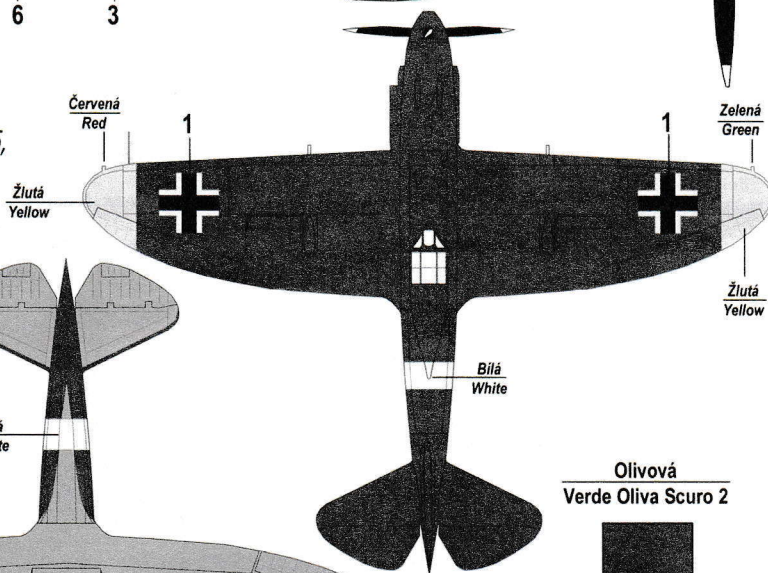

Olivová
Verde Oliva Scuro 2



Světle šedá
Grigio Azzurro Chiaro