



Revised Edition

Sexy Lanes



ZTZ48-015
ZTZ72-015





Sexy Lanes

SUGAR'S BLUES

Lancaster B X KB864 NA-S, 428 "Ghost" Sqd,
 Middleton St. George, May 1945
 Returned to Canada one month later.
 Martin mid-upper with twin 50s
 mounted further forward.
 Paddle blades.



PICCADILLY PRINCESS

Lancaster B I NG347 QB-P 424 Sqd, Skipton on Swale, 1945
 Retired May 1947



FANNIN' FANNY

Lancaster B I ZL-F NX554, 427 Sqd, scrapped Oct 1946

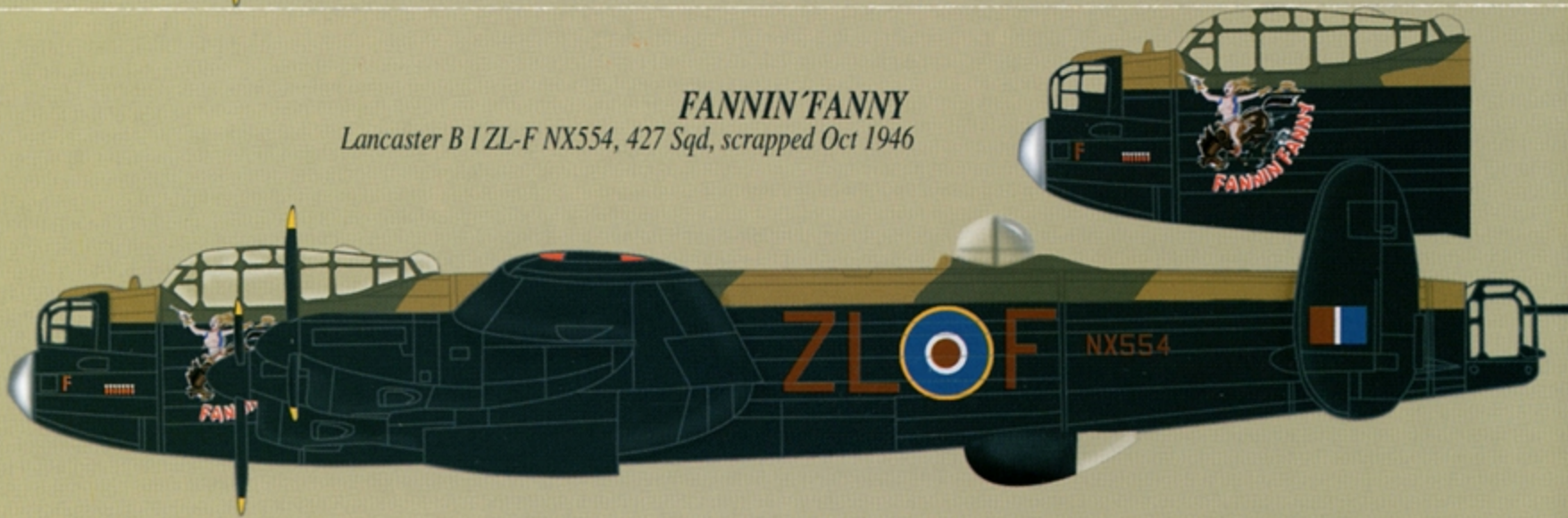

FAIR FIGHTER'S REVENGE

Lancaster B III ME812 AS-F, 166 Sqd, Kirmington, June 1944
 Went on to fly 100+ missions, most of them as P4-F of 153Sqd (Oct 1944).
 Survived the war. Retired on Oct 1946.



Researched by Eli Raphael

LADY ORCHID

Lancaster B X WL-O KB895, 434 Sqd, Croft, Yorkshire May 1945.
Sold to a farmer for scrap on Jan 1947. Years later her mid section was used
to restore the Mynarski Memorial Lancaster.

Note: Martin turret, upper fuselage



ZOMBIE

Lancaster B II LL725, EQ-Z, 408 Sqd, Linton-on-Ouse, March 1944
MIA against Hamburg raid 16/03/44. Maple leaves missions denote raids in occupied
countries in Europe.



Thanks to Steve Moss
for the Sugar's Blues information.

ZTZ48/015
ZTZ72/015

DATA PLACEMENT

Sexy Lancs

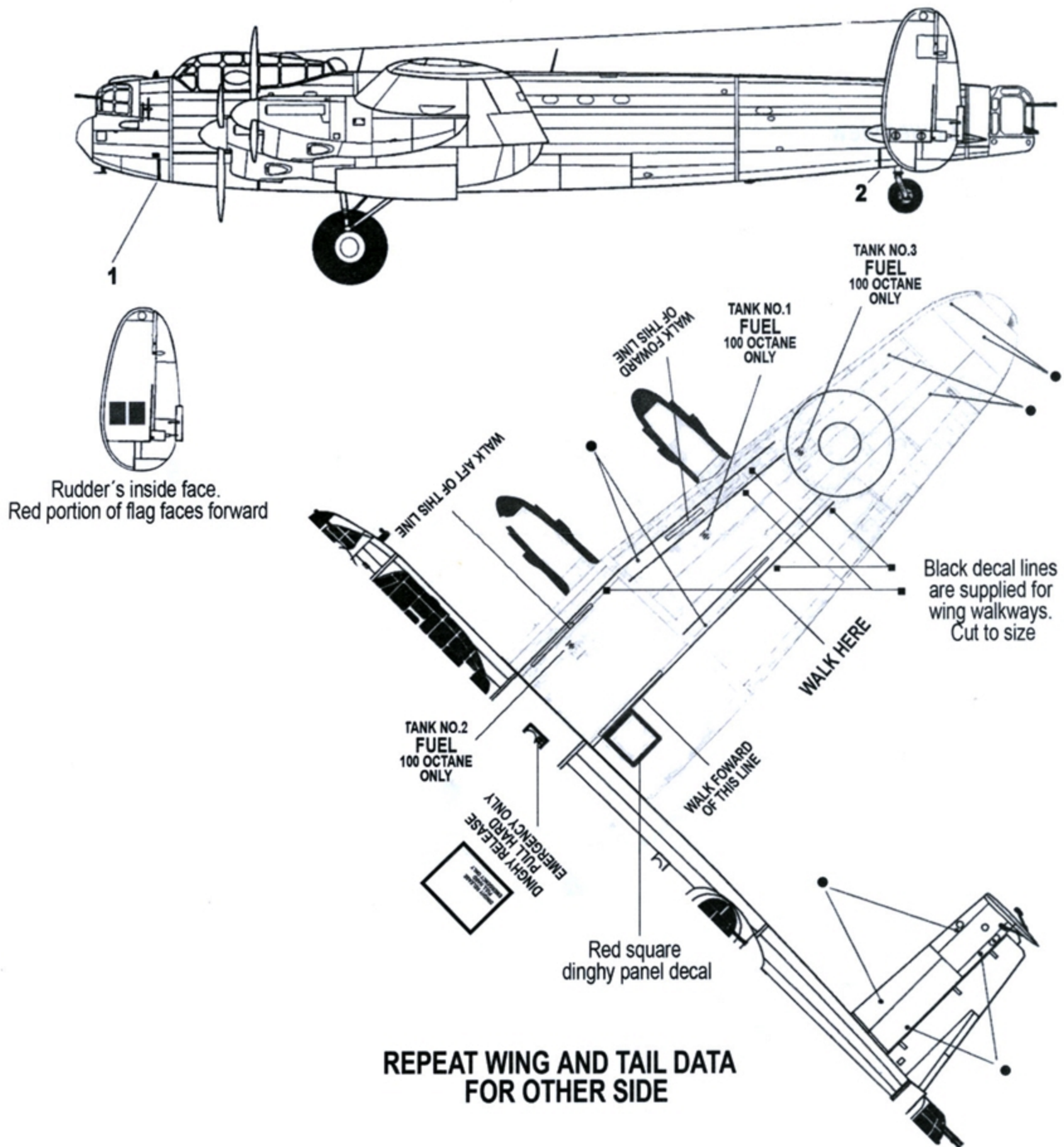

References: Lancaster Squadrons 1944 - 45, Osprey Combat Aircraft No.35 by Jon Lake.
RAF & RCAF Aircraft Nose Art in World War II by Clarence Simonsen, Hikoki publications.

Lower view

