

1

Cement Parts
Collar
Pieben
Pegs
Legal
Inglare
Cob
Kleven

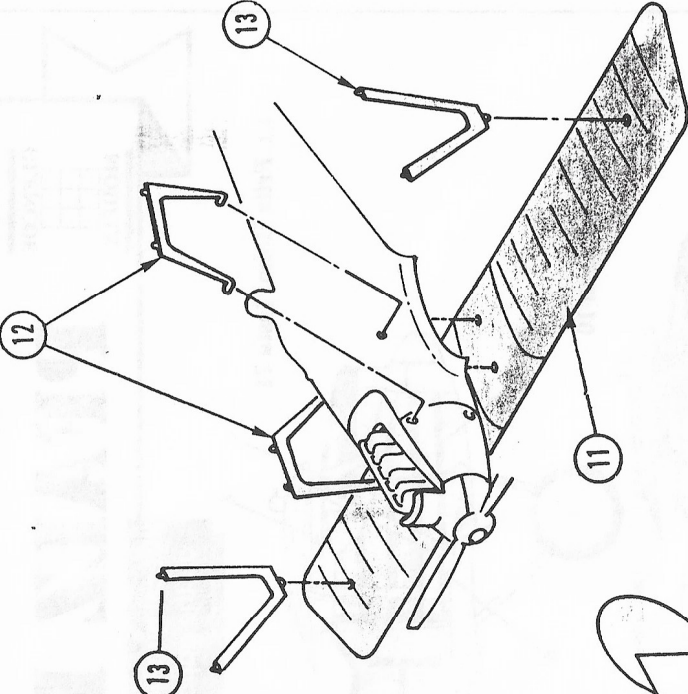

2

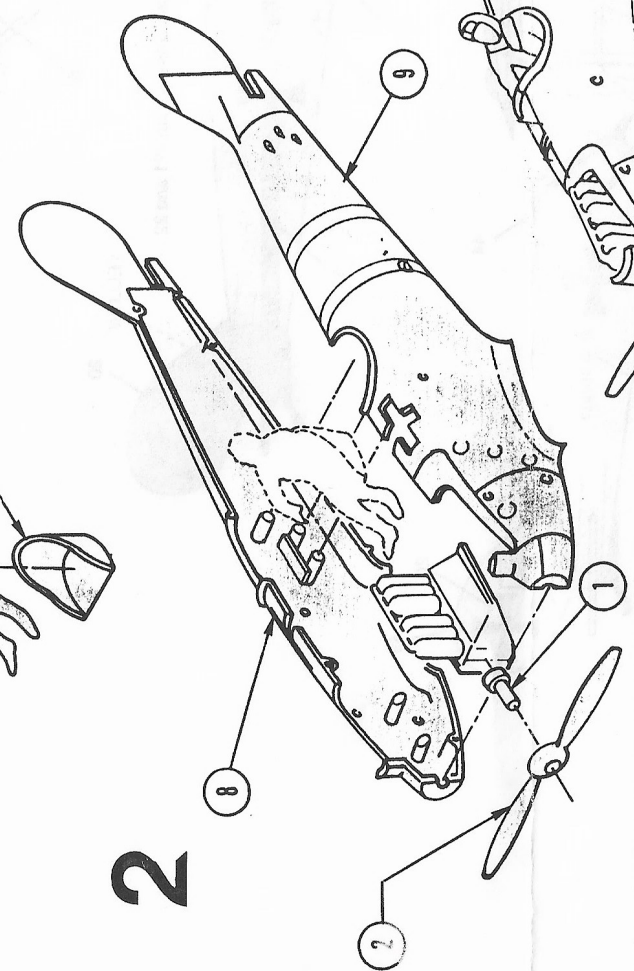

3

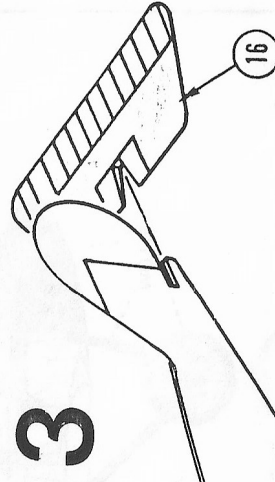

4

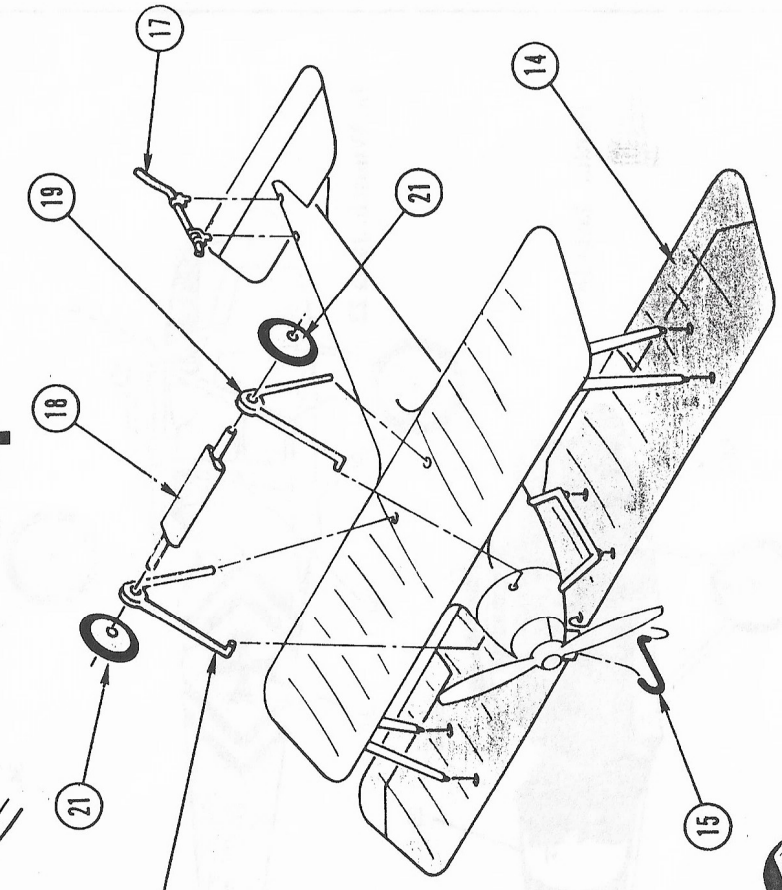

AIR WAR 1914-1918

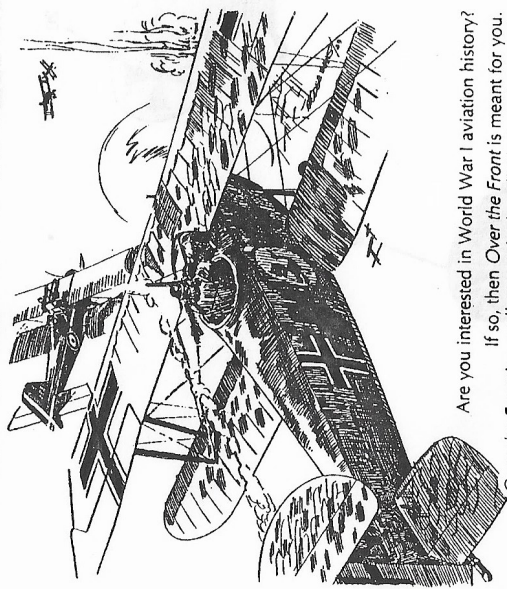

Are you interested in World War I aviation history?
If so, then *Over the Front* is meant for you.
Over the Front is a well-researched, well-illustrated quarterly journal for people interested in all phases of military aviation during The 1914-1918 War. You receive four issues per year for \$30.00 (U.S.). First Class and Air Mail rates available on request.

Subscribe today!
Send your check or money order to:
Membership Secretary
League of World War I Aviation Historians
P.O. Box 7504, Charlottesville, VA 22906 / U.S.A.



History in the Making

PFALZ D III DECAL PLACEMENT

Decal numbers not shown are used on the opposite side of the airplane.

© GLENCOE MODELS, 1995
ALL RIGHTS RESERVED

Lt. Fritz Höhn, Jasta 21

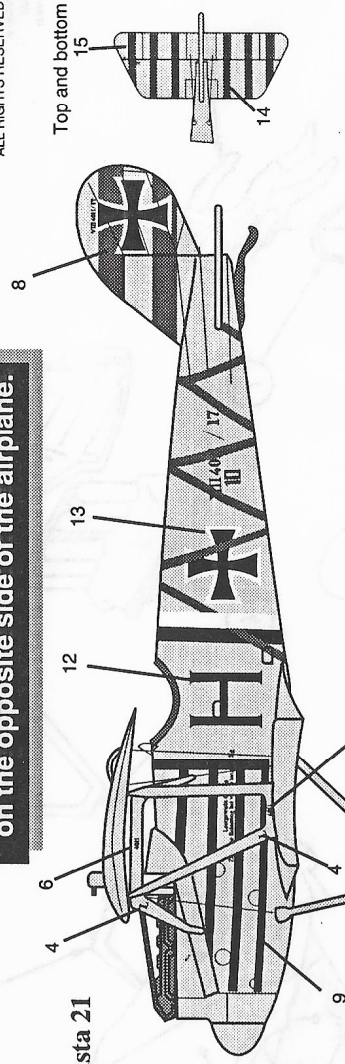

Lt. Klein, Jasta 10

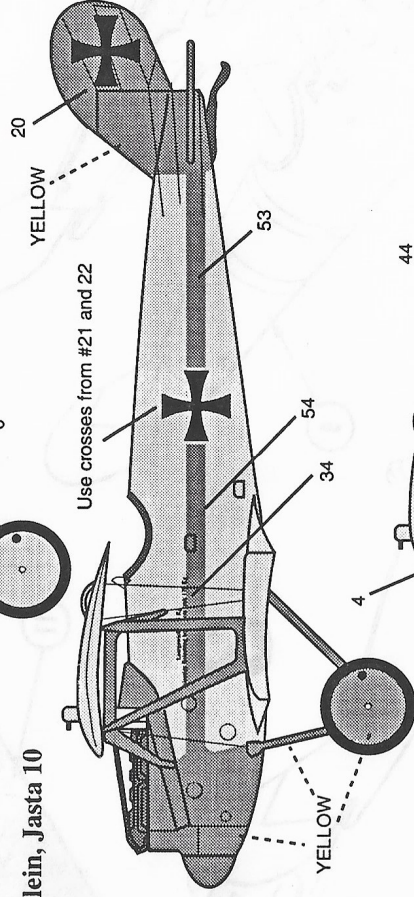

Lt. Hegeler, Jasta 15

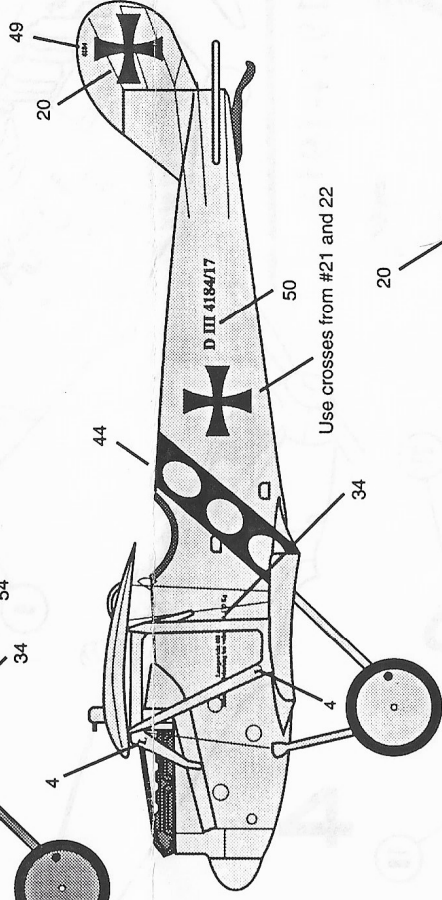

Lt. Wunsch, Jasta 22

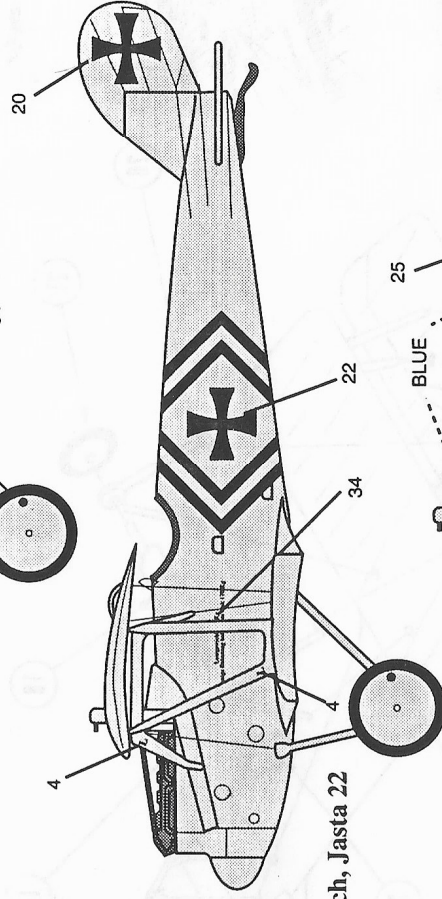

Buttlar, Jasta 18

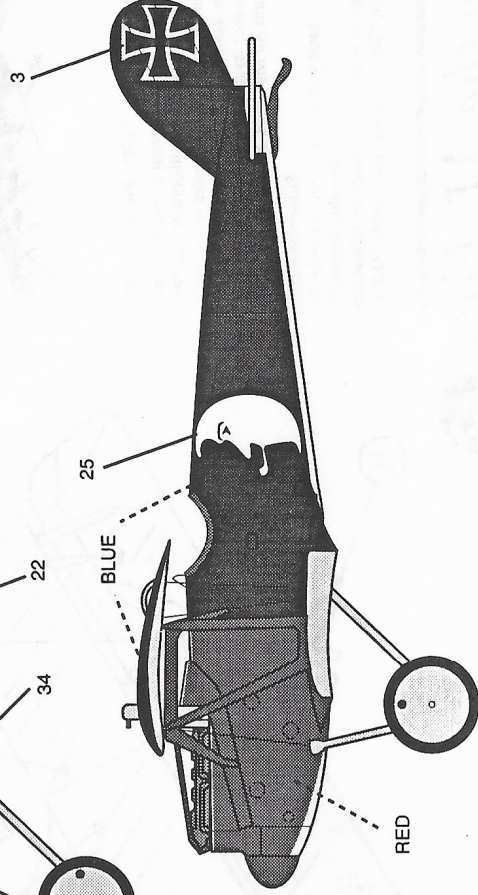

Jasta 10

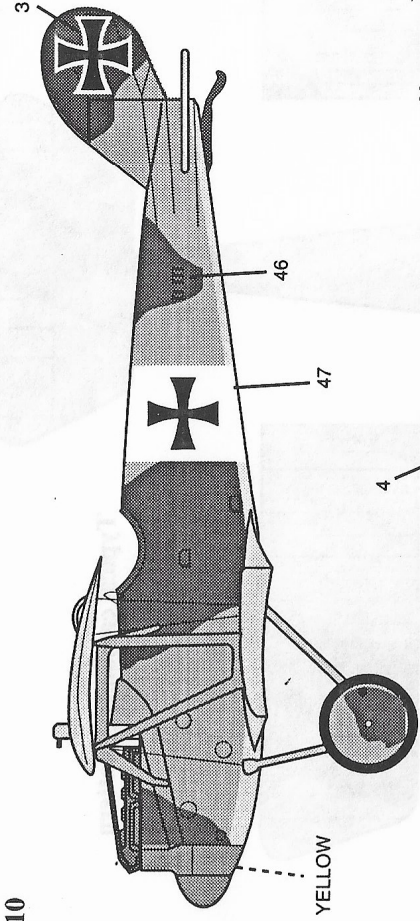

YELLOW

**Flugmaat Undiener,
Marine-feld Jasta III**

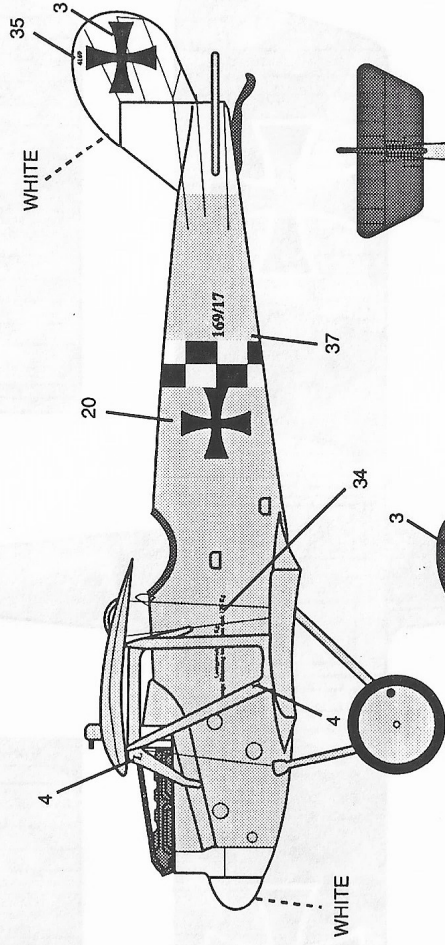

WHITE

WHITE

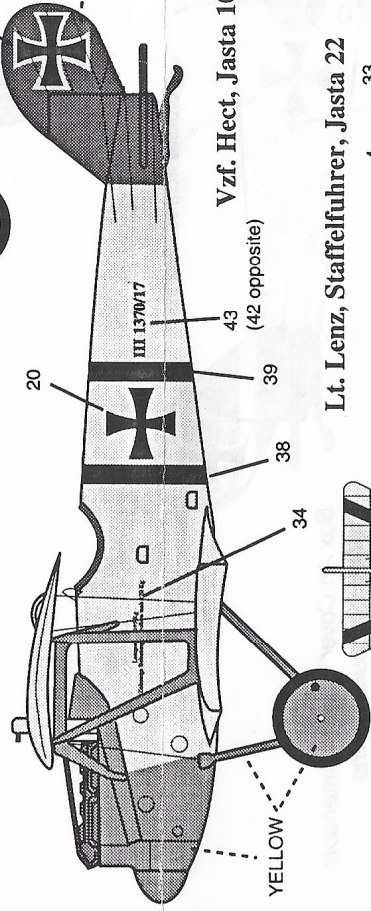

YELLOW

GREEN

Vzf. Hect, Jasta 10

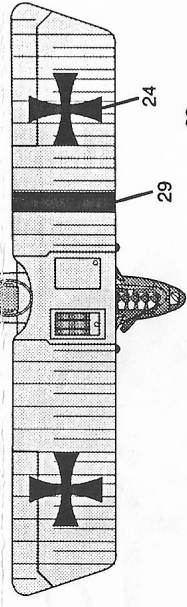

Lt. Lenz, Staffelfuhrer, Jasta 22

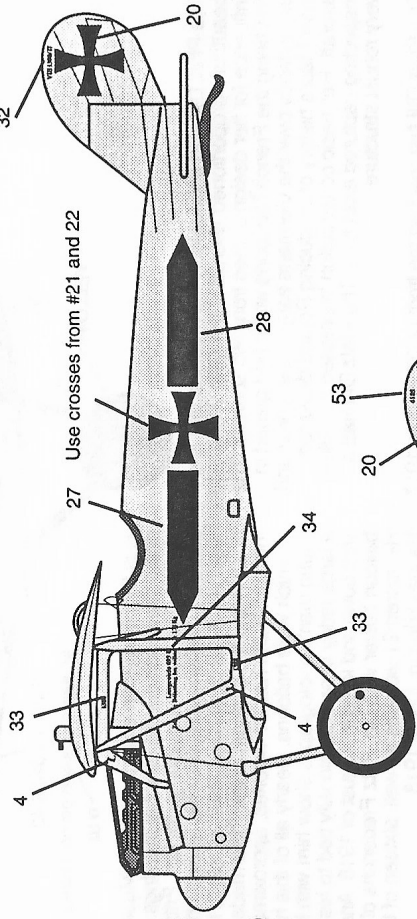
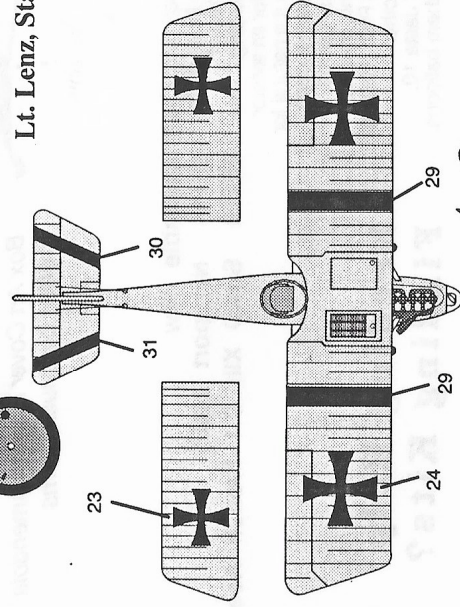

Use crosses from #21 and 22

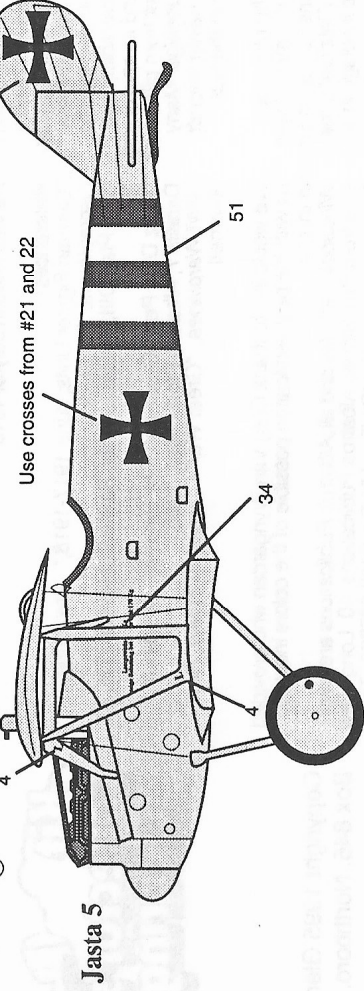

Use crosses from #21 and 22

For more detailed information on the Pfalz D III markings, please refer to the illustrations on the kit box.

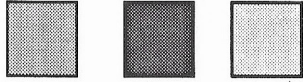

Mauve (Lilac or light purple)

Dark green

Silver-Gray (Silbergrau)

Typical camouflage pattern

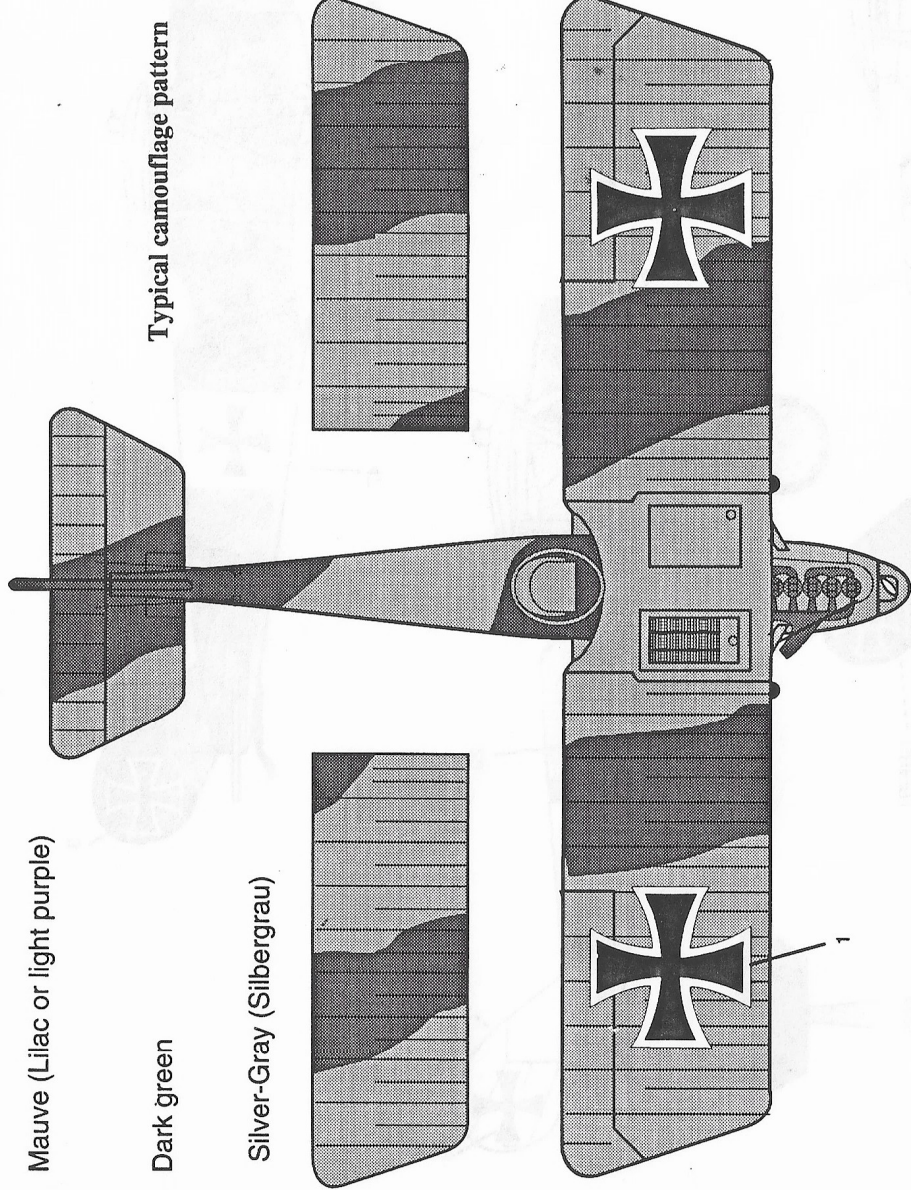

Vzfw. Barth, Jasta 10

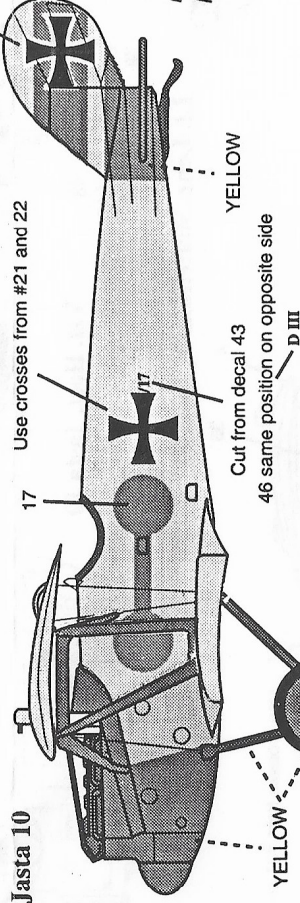

Box Art Cover by John Amendola
Profiles by Chuck Sterns

This kit includes an extensive Scale-Master Invisi-Clear decal sheet with eleven optional markings. Much of the sheet comprises the markings for Lt. Fritzhn of Jasta 21 who is renown for his "balloon busting." This was one of the most dangerous missions for an aviator in WWI and the strength of the Pfalz made it a natural for this. Lt. Hohn had 21 victories, approximately sixteen of which were balloons. Nearly all of this handsome young man's photographs show him with his mascot, a large teddy bear, occasionally tied to his Pfalz. He was shot down and killed in August of 1918. Another balloon buster was Lt. Fritz Frederichs of Jasta 10. He scored 21 victories as well, sixteen of them balloons. He was killed in July of 1918.

Available now
05114 Nieuport 28C.1
05118 SPAD XIII C.1 French Aces

The Pfalz D.III was undoubtedly the most elegant and beautifully proportioned aircraft of the First World War. Influence for her design comes from two sources. The first being the French Nieuports which had gained in ascendancy over the Germans early in the airwar and from Pfalz's history of producing Roland designed aircraft. Her basic construction impressed the Allies inspecting captured examples. The Pfalz D.III had a very robust structure.

The Pfalz D.III first reached the front on 31 August 1917 and equipped many Jastas. The Pfalz D.III has been a much maligned machine but much of that is unfounded. Its robust and strong structure allowed it to receive a great deal of punishment. It was better in dive than its Albatros counterpart. The D.III's maneuverability and visibility were reported as "excellent" and its speed and climb as "good". The greatest complaint from pilots was from having D.III's guns buried in the fuselage. Many pilots refused to retire their Pfalzes for newer aircraft until they received the Fokker D.VII late in the war.

The Pfalz D.III was powered with a 160hp Mercedes D.III engine with a maximum speed of 102 mph. It was armed with two fixed LGM machine guns buried in the fuselage. In the later improved version, Pfalz D.IIIa, the machine guns were placed on top of the fuselage in a more traditional fashion.

Needing Help Finding Kits?

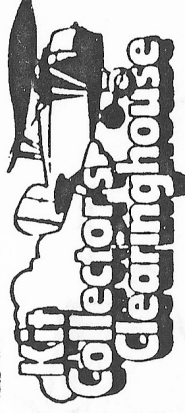

References
"German Fighter Units, June 1917-1918," Alex Imrie, Osprey/AirWar 17, 1978.
"The Pfalz D.III," Peter L. Gray, Profile Publications No. 43, 1966.
"Pfalz D.III," Peter Grosz and Ray Rimmel, Windsock Datafile 7, Albatros Productions, 1988.
WWI Warplanes, "Great War" Classics in Profile, Ray Rimmel

We would like to thank Greg Van Wyngarden who provided us with the best verification possible of the colors included in this kit.
Windsock Datafiles and all Albatros Publications are available from Ray Rimmel, Albatros Publications, 10 Long View, Berhamstead, Herts, HP4 1BY, UK Tel: 0442 875838. These publications are well recommended along with *Over the Front*.

Copyright 1995 Glencoe Models Inc.
Box 846, Northboro, MA 01632

