

1/72 SCALE PLASTIC KIT

ProfiPACK
edition

#7059



INTRO

MiG-15 fighter aircraft has become one of the post-WW2 aircraft development symbols, especially the one of the communist block lead by Soviet Union. It played crucial role in the Korean War, took part of the Suez Crisis as well as in other less important conflicts in Asia, Africa, Caribbean etc. The key parts of the aircraft – the engine and the swept wing – were not developed in Soviet Union but in other countries. The swept wing was elaborated by German researchers and found its way to Soviet Union as a part of the war prize. The engine, under licence built Rolls Royce Nene, was created by British engineers. The specifications that led to the MiG-15 birth were issued in 1947. Temporary Soviet attempts to develop their own jet engine failed and captured German Jumo 004 and BMW 003 jet engines became obsolete. Under such a situation Soviet Union decided to buy few tens of British Nene I, Nene II and Derwent V engines. The licence to build these engines was built also. Three types of the fighter airplanes were built using these engines. The Derwent was the heart of Yak-23 with straight wing and Nene found its way to Lavochkin 168 and MiG-15, both with the swept wing and horizontal stabilizer. Soviets believed that at least one of two different wing designs will fulfil the requirements. Finally Yak-23 and MiG-15 entered the serial production but only the latter became world-wide known thanks to its performance and high numbers of airplanes manufactured. The first prototype under I-301 designation was finished on December 19th and made its maiden flight on December 30th, 1947. The second prototype powered by more powerful Nene II engine flew for the first time on May 27th, 1948. The third prototype joined previous two ones afterwards but test flight were so satisfying that serial production of the aircraft under designation MiG-15 was ordered on July 17th, 1948. The first production aircraft was assembled in June 1949 and the serial production was step by step launched in many facilities across the Soviet Union. The production MiG-15 was powered by RD-45F engine and armed with two 23mm cannons NS-23KM and one 37mm cannon N-37. The various bombs and unguided air-to-ground missiles (LR-130 and S-21) could be attached to the hardpoints on the wing undersurface. A bit later, in 1950 – 1951 the production of MiG-15bis begun. Powered by VK-1 engine with the higher output these were easily recognizable thanks to the modified aerial brakes on the tail. The „bises“ were produced till 1953 when the MiG-17 replaced them on the assembly lines. The Fifteens were manufactured outside the Soviet Union. The Aero and Let facilities in Czechoslovakia and PZL Mielec in Poland built them in relatively high numbers. The two-seaters were built by Chinese also. Apart of the fighters more variants were built. The two-seater UTI MiG-15 was flown as a training aircraft. The majority of them left the production line in Czechoslovakia. In Czechoslovakia many MiG-15s and bises were underwent the modification to the fighter-bomber MiG-15SB and MiG-15bisSB version with four underwing pylons. The MiG-15R / MiG-15bisR was the recon version with cameras and MiG-15T served as a target-towing aircraft. The Fifteens were given with the NATO code designation. The single-seaters were coded Fagot A for MiG-15 and Fagot B for MiG-15bis. The two-seater UTI MiG-15 was known under the codename Midget.

ÚVODEM

Stíhací letoun MiG-15 se stal jedním ze symbolů rozmachu poválečného letectví, zejména pak vývoje techniky na straně vojenského bloku pod kuratelou Sovětského svazu. Zásadní roli hrál ve válce v Koreji, účastnil se bojů během Suezské krize a řady dalších více či méně významných konfliktů. Za klíčové součásti letounu – motor a šípové křídlo – však Sověti vděčí jiným národům. Šípové křídlo vzniklo na základě výzkumných prací německých konstruktérů a do Sovětského svazu putovaly jako válečná kořist. Motor, licenční Rolls Royce Nene, pak vznikl na půdě Velké Británie. Zadání směřující k MiGu-15 se datuje do roku 1947. Dosavadní pokusy s proudovými motory domácí provenience skončily neúspěchem a kořistní německé Jumo 004 a BMW 003 svými výkony již nestačily. Proto se Sovětský svaz odhodlal k nákupu britské licence na výrobu motorů Nene a Derwent a několika desítek již hotových kusů motorů Nene I, Nene II a Derwent V. Zatímco okolo Derwentu byl postaven Jak-23 s přímým křídlem, okolo Nene vznikly Lavochkin 168 a MiG-15 se šípovým křídlem a ojedinělými plochami. Rozdílné pojetí konstrukcí mělo zajistit, že v případě neúspěchu jedné bude možné využívat druhou. Nakonec se do sériové výroby dostal Jak-23 a MiG-15, ale MiG-15 svého konkurenta zcela zastínil. Jak počtem vyrobených kusů, tak celosvětovou slávou. Prototypy MiGu-15 pod značením I-301 byl dokončen 19. prosince 1947 a poprvé se vyznesl do vzduchu 30. prosince téhož roku. Druhý prototyp již dostal výkonnější motor Nene II a první let vykonal 27. května 1948. Záhy je doplnil ještě třetí prototyp, ale zkoušky probíhaly natolik uspokojivě, že již 17. července 1948 padlo rozhodnutí o sériové výrobě typu pod označením MiG-15. První sériový letoun byl dokončen v červnu 1949 a postupně se rozeběhla výroba v několika továrnách po celém Sovětském svazu. MiG-15 poháněl motor RD-45F, což byl licenční Nene II. Výzbroj tvořila dvojice 23 mm kanonů NS-23KM a jeden 37 mm kanon N-37. Pod křídlo bylo možné podvěsit pumy a neřízené protizemní rakety (LR-130 a S-21). Záhy, již v letech 1950 – 1951 začaly v montážních linek sjíždět MiGy-15bis. Poháněl je výkonnější motor VK-1 a vizuálně se odlišovaly mj. jiným tvarem aerodynamických brzd na zádi trupu. Výroba bisů probíhala až do roku 1953, kdy je nahradily MiGy-17. Produkci patnáctek se zabývaly i továrny mimo Sovětský svaz. Jednalo se o československé závody Let a Aero, polský PZL Mielec a dvoumístná verze byla stavěna také v Číně. Vznikla řada verzí a variant. Nejpočetněji zastoupený byl cvičný dvoumístný UTI MiG-15. Vyráběly se zejména v Československu. V této zemi vynikla také stíhací bombardovací verze MiG-15SB a MiG-15bisSB se čtyřmi závěsníky pod křídlem. Vyráběly se též průzkumné MiGy-15R / MiG-15bisR a pro tahání cvičných terčů určené MiG-15T. Typ dostal v systému kódových označení NATO jména Fagot A a Fagot B pro MiG-15 a MiG-15bis. Označení Midget patřilo dvoumístnému UTI MiG-15.

ATTENTION

* UPOZORNĚNÍ

* ACHTUNG

* ATTENTION

* 注意



Carefully read instruction sheet before assembling. When you use glue or paint, do not use near open flame and use in well ventilated room. Keep out of reach of small children. Children must not be allowed to suck any part, or pull vinyl bag over the head.



Před započítím stavby si pečlivě prostudujte stavební návod. Při používání barev a lepidel pracujte v dobře větrané místnosti. Lepidla ani barvy nepoužívejte v blízkosti otevřeného ohně. Model není určen malým dětem, mohlo by dojít k požití drobných dílů.

INSTRUCTION SIGNS

* INSTR. SYMBOLY

* INSTRUKTION

* SINNBILDEN

* SYMBOLES

* 記号の説明

OPTIONAL
VOLBABEND
OHNOUTSAND
BROUSITOPEN HOLE
VYVRTAT OTVORSYMMETRICAL ASSEMBLY
SYMETRICKÁ MONTÁŽREMOVE
ODRŽNOUTREVERSE SIDE
OTOCITAPPLY EDUARD MASK
AND PAINT
POUŽIT EDUARD MASK
NABARVIT

PARTS

* DÍLY

* TEILE

* PIĘCES

* 部品

PLASTIC PARTS

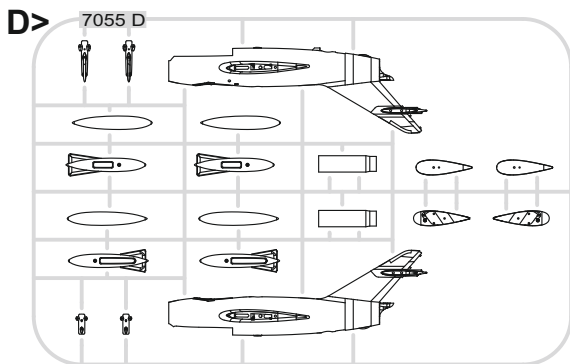
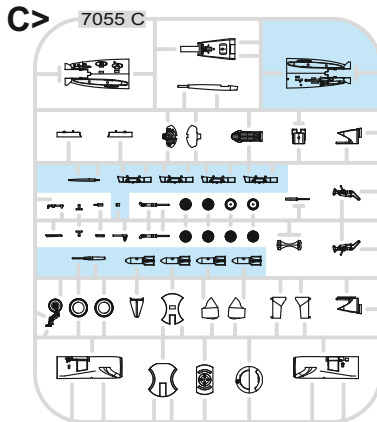
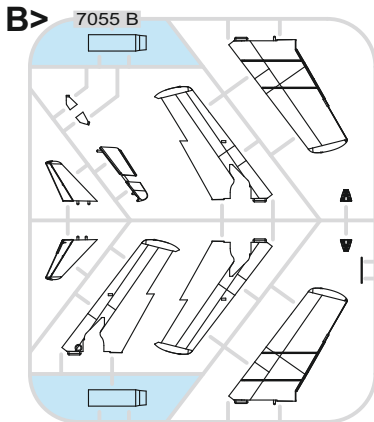
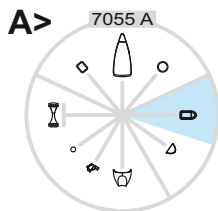

PE - PHOTO ETCHED DETAIL PARTS

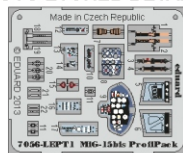
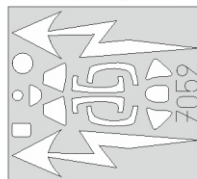
eduard
MASK

-Parts not for use. -Teile werden nicht verwendet. -Pièces à ne pas utiliser. -Tyto díly nepoužívejte při stavbě. - 使用しない部品

COLOURS

* BARVY

* FARBEN

* PEINTURE

* 色

GSI Creos (GUNZE)		MISSION MODELS	
AQUEOUS	Mr.COLOR	PAINTS	
H3	C3	[MMP-003]	RED
H4	C5	[MMP-048]	BLUE
H6	C6	[MMP-004]	GREEN
H12	C33	[MMP-047]	FLAT BLACK
H18	C28	[MMM-002]	STEEL
H25	C34		SKY BLUE
H26	C66		BRIGHT GREEN
H47	C41	[MMP-012]	RED BROWN
H86	C119	[MMP-119]	SANDY YELLOW
H87	C115	[MMP-057]	LIGHT BLUE
H77	C137	[MMP-040]	TIRE BLACK
H305	C305	[MMP-084]	GRAY

GSI Creos (GUNZE)		MISSION MODELS	
AQUEOUS	Mr.COLOR	PAINTS	
[H308]	C308	[MMP-073]	GRAY
[H340]	C340		FIELD GREEN
	C367	[MMP-061]	BLUE GRAY
	C523		GRASS COLOR
Mr.METAL COLOR		METALLICS	
[MC214]		[MMM-001]	DARK IRON
[MC218]		[MMM-003]	ALUMINIUM
Mr.COLOR SUPER METALLIC		METALLICS	
[SM201]		[MMC-001]	SUPER FINE SILVER
[SM204]			SUPER STAINLESS
[SM209]		[MMC-001]	CHROME SILVER

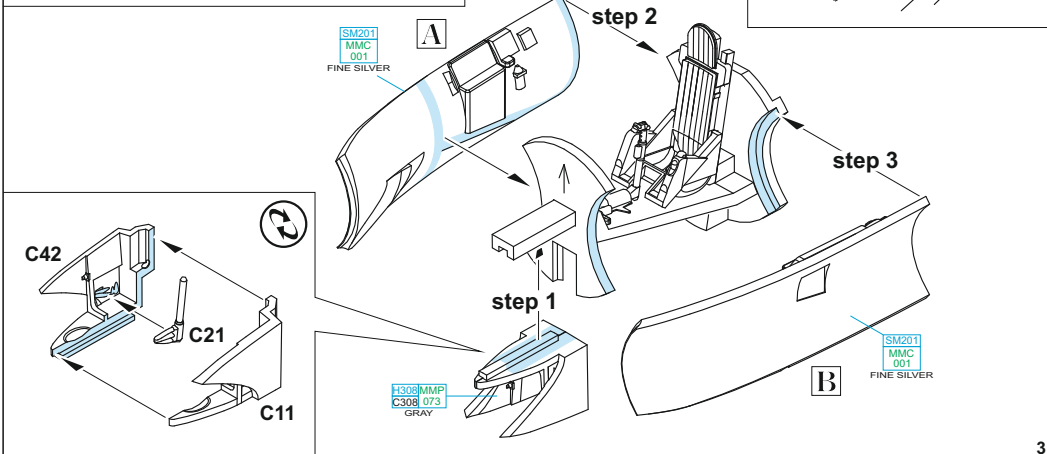
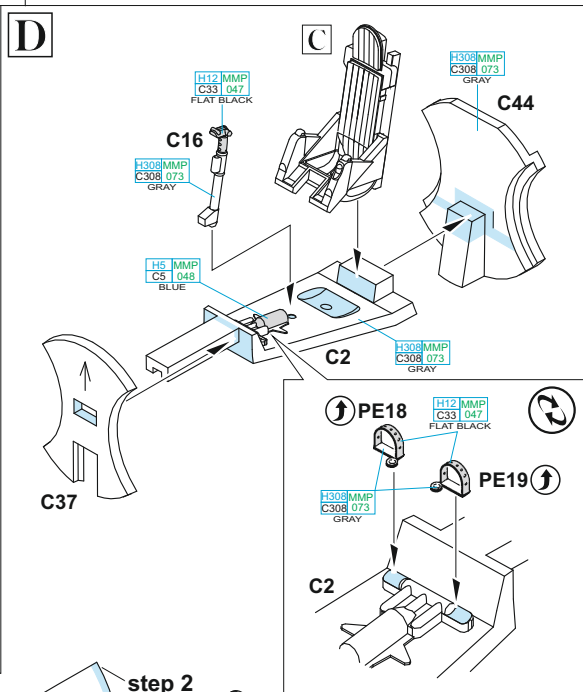
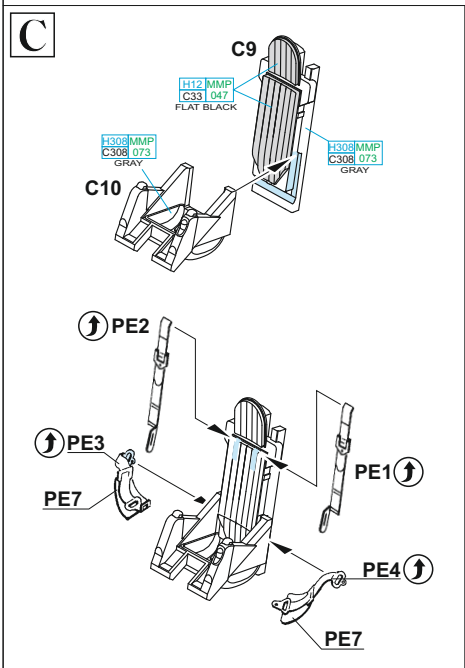
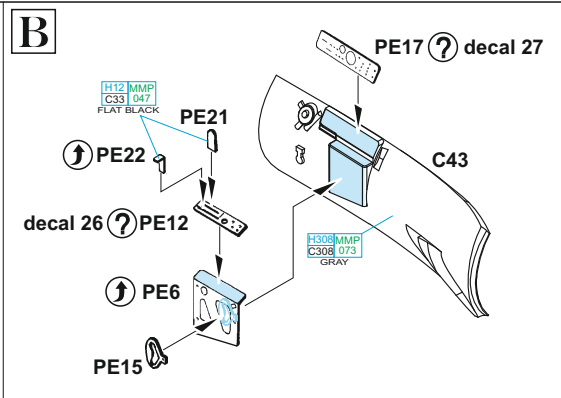
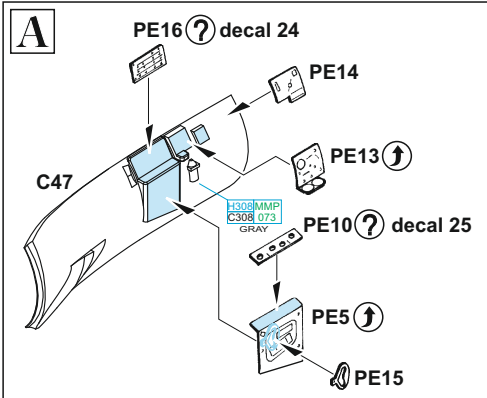

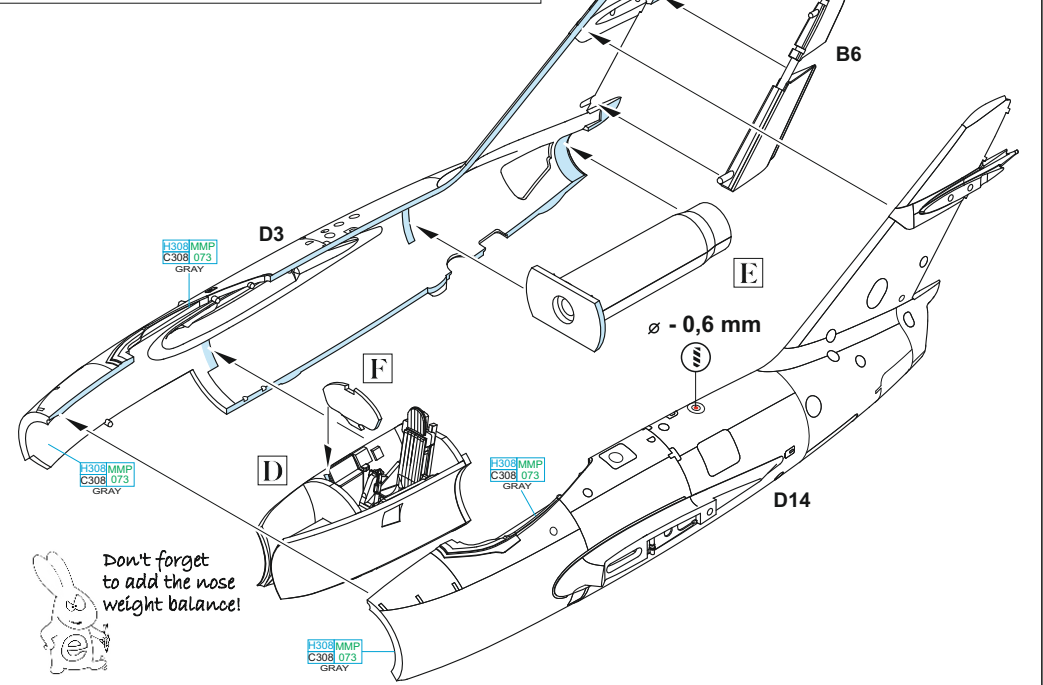
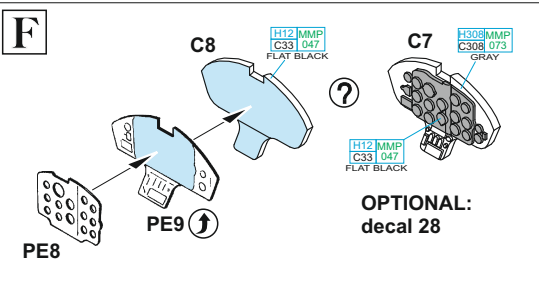
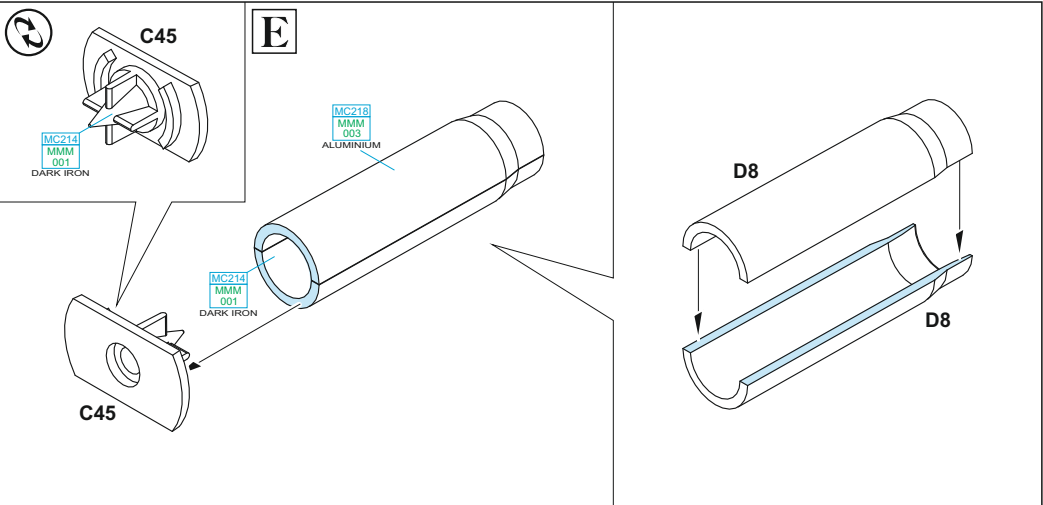

10,5 mm

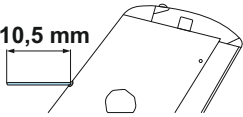

G

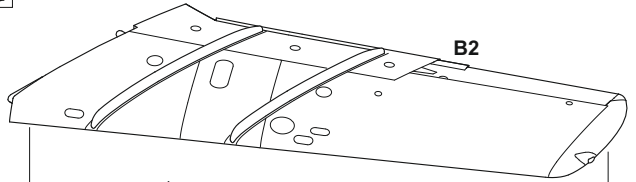

B2

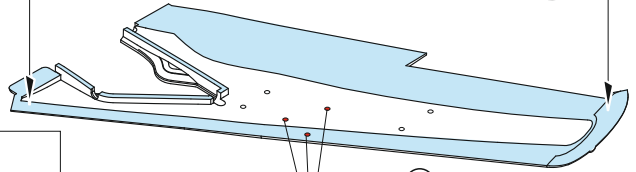

⊕ ⊖ ∅ - 0,8 mm
EXTERNAL FUEL TANK

B10 ⊕ **B11**

B10 - MARKINGS B; C; D; E

B11 - MARKING A

B13

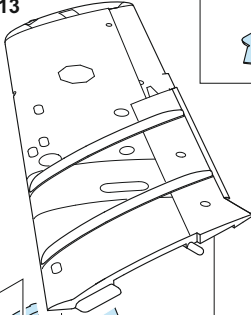

B14

∅ - 0,8 mm

⊕ ⊖
EXTERNAL FUEL TANK

B7

B5

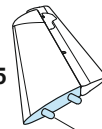

B9

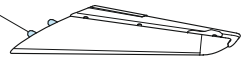

G

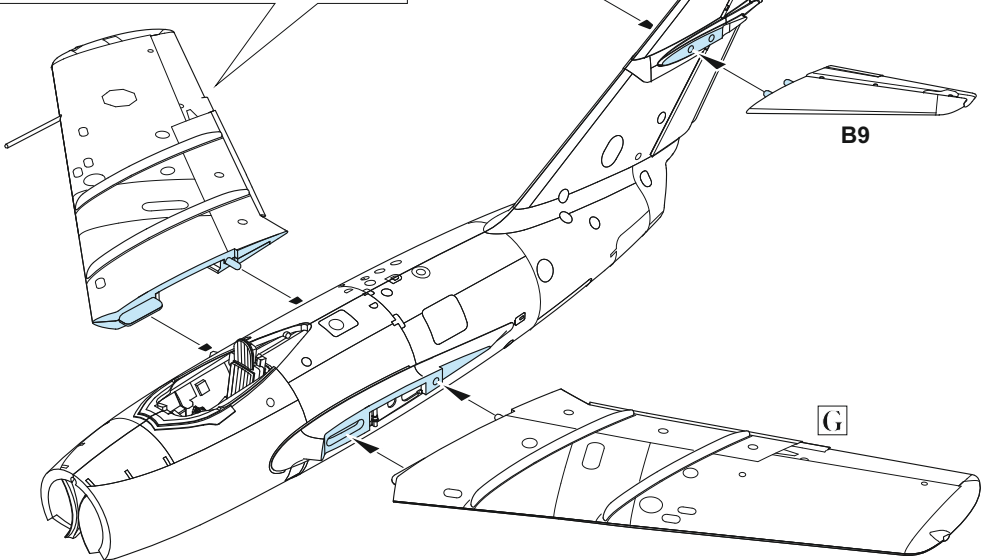

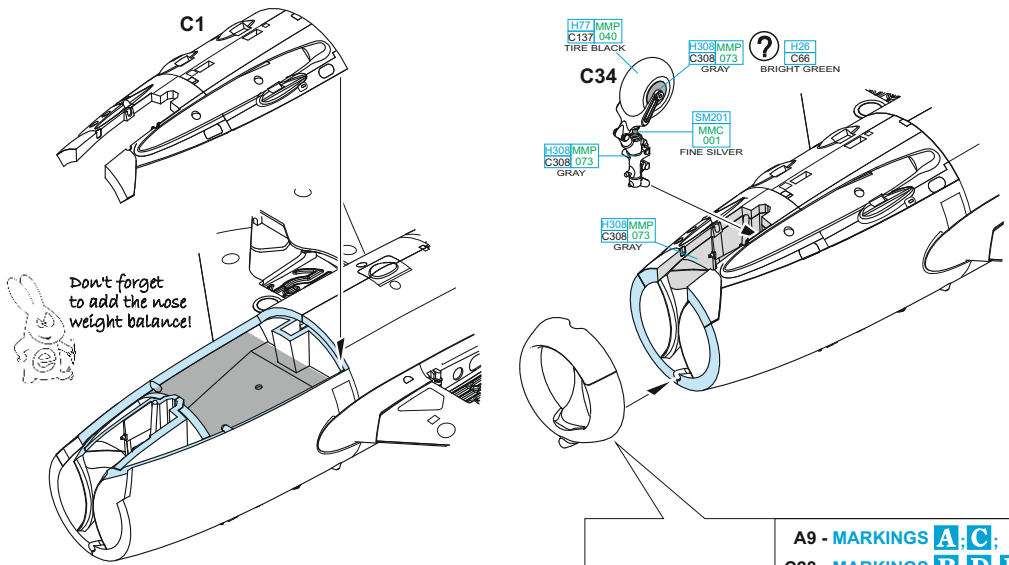

A9 - MARKINGS A; C;
C28 - MARKINGS B; D; E

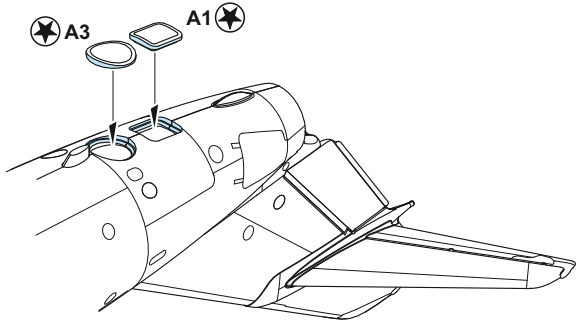
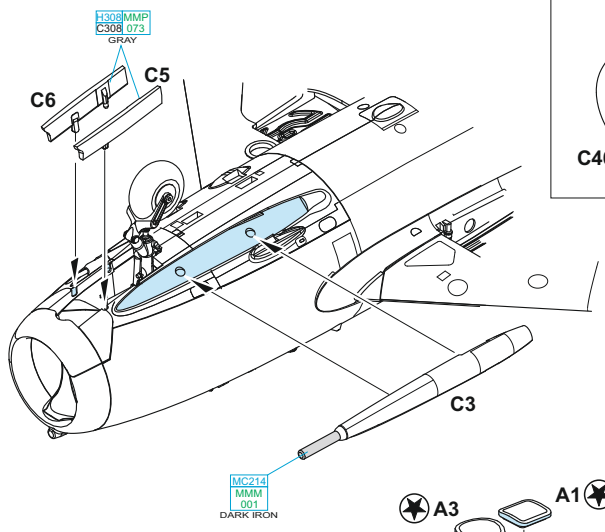
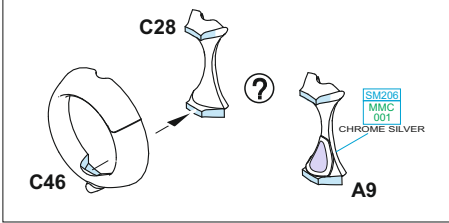

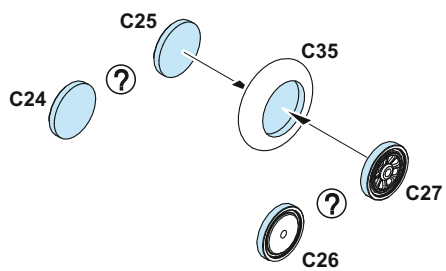
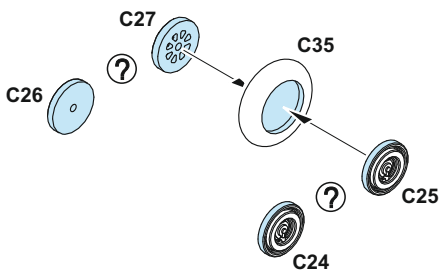
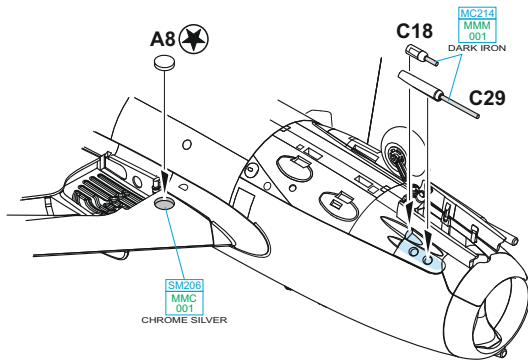

L

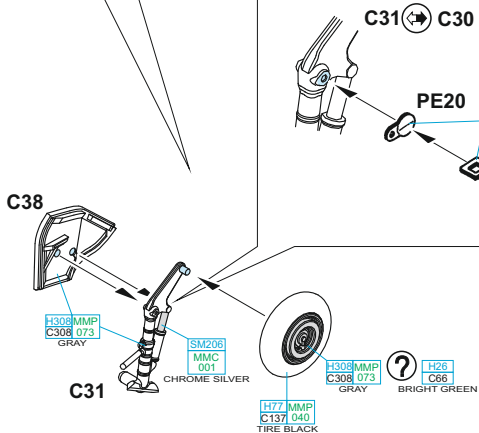

R

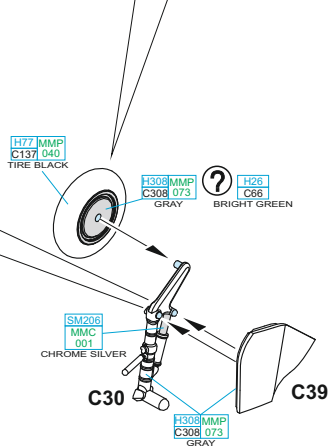

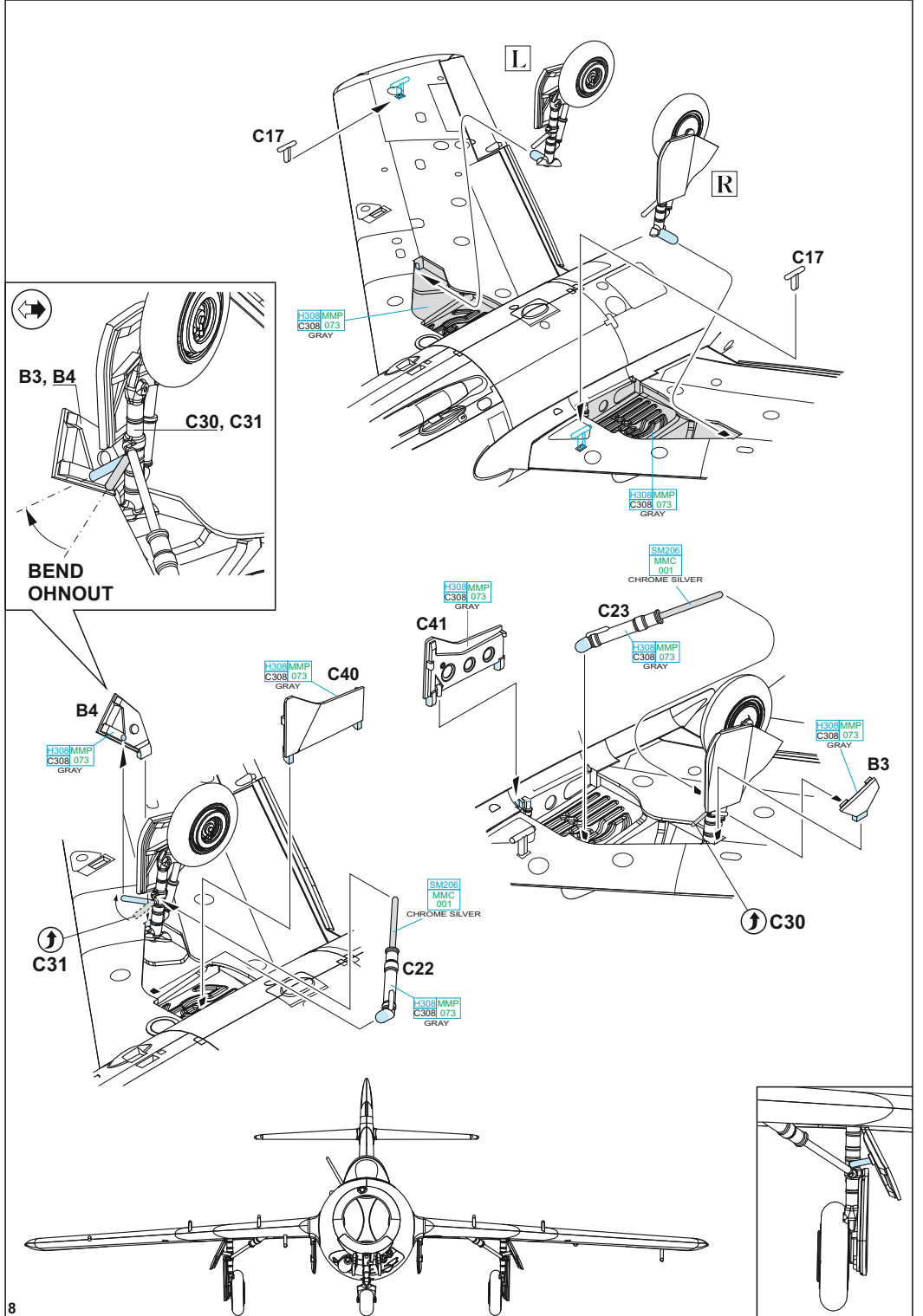

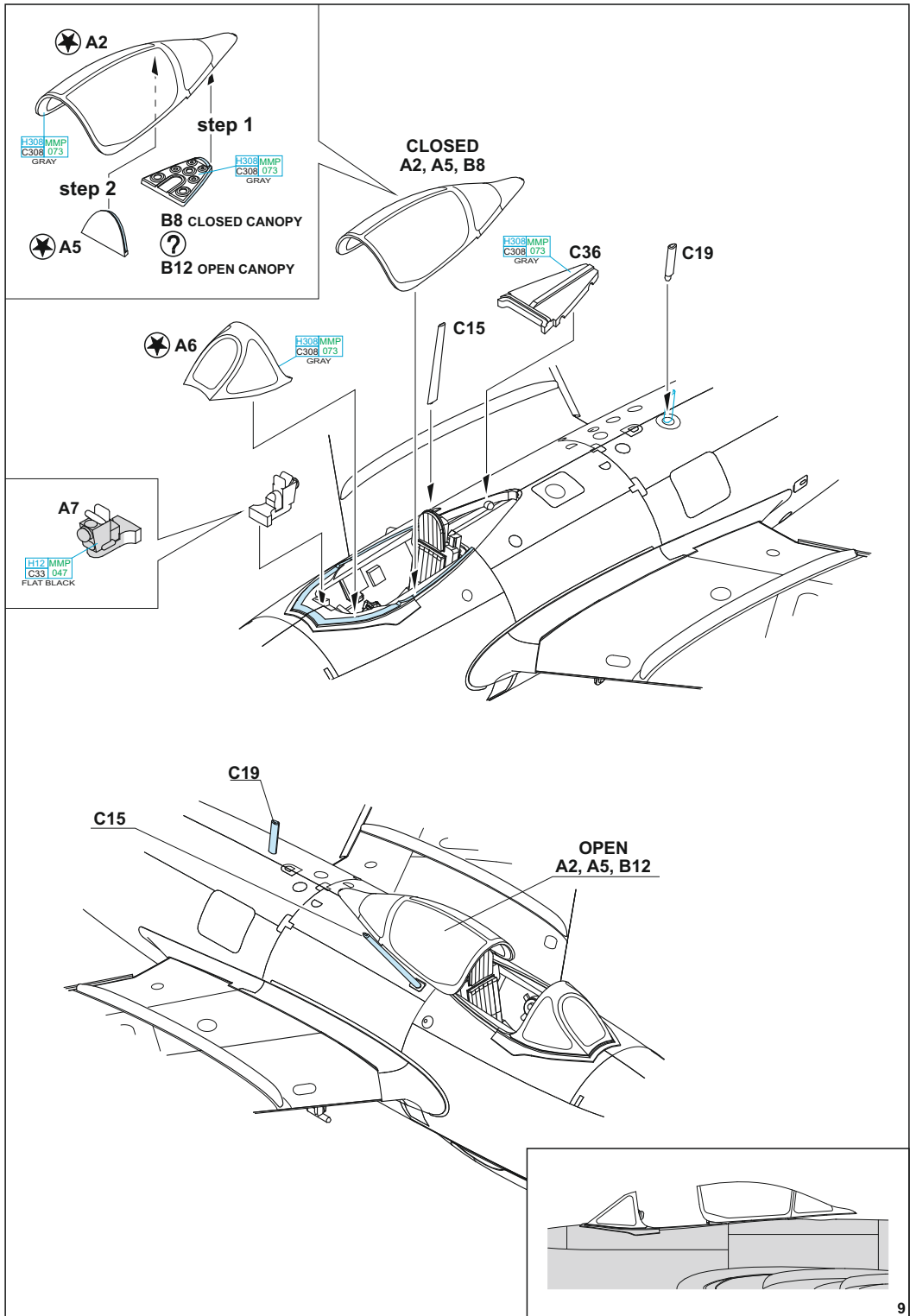

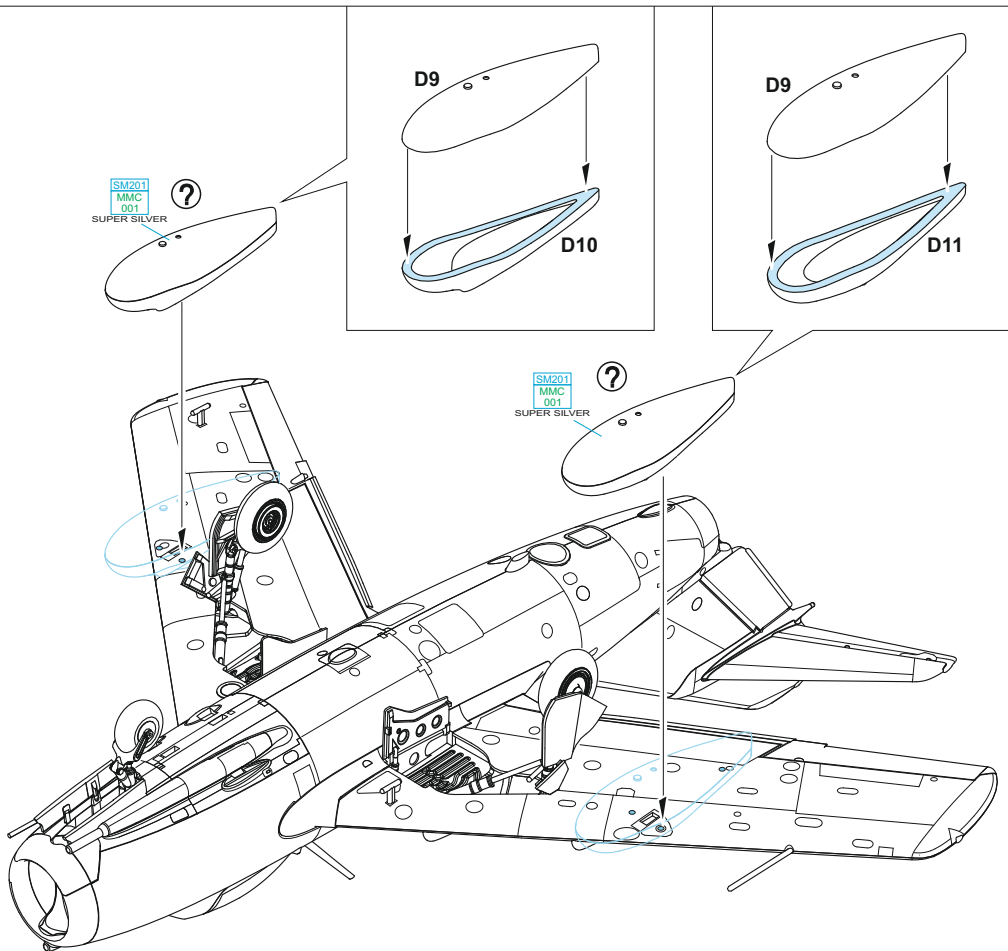
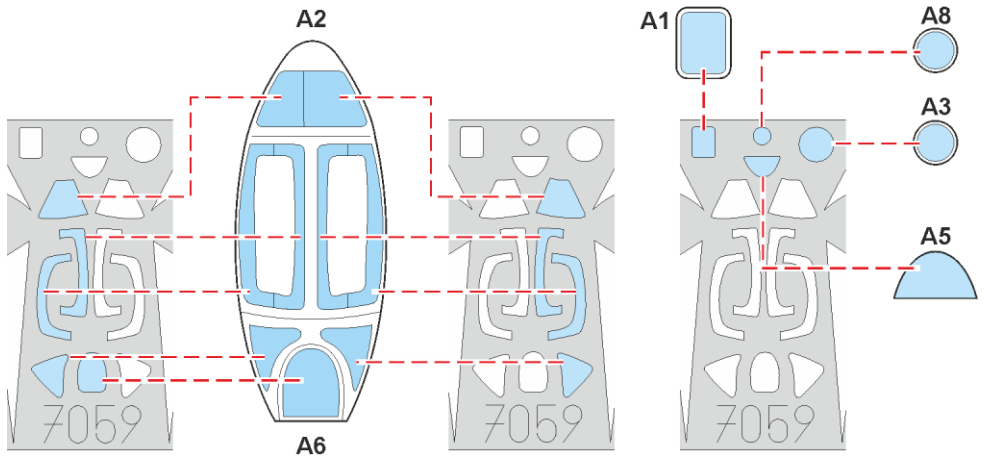

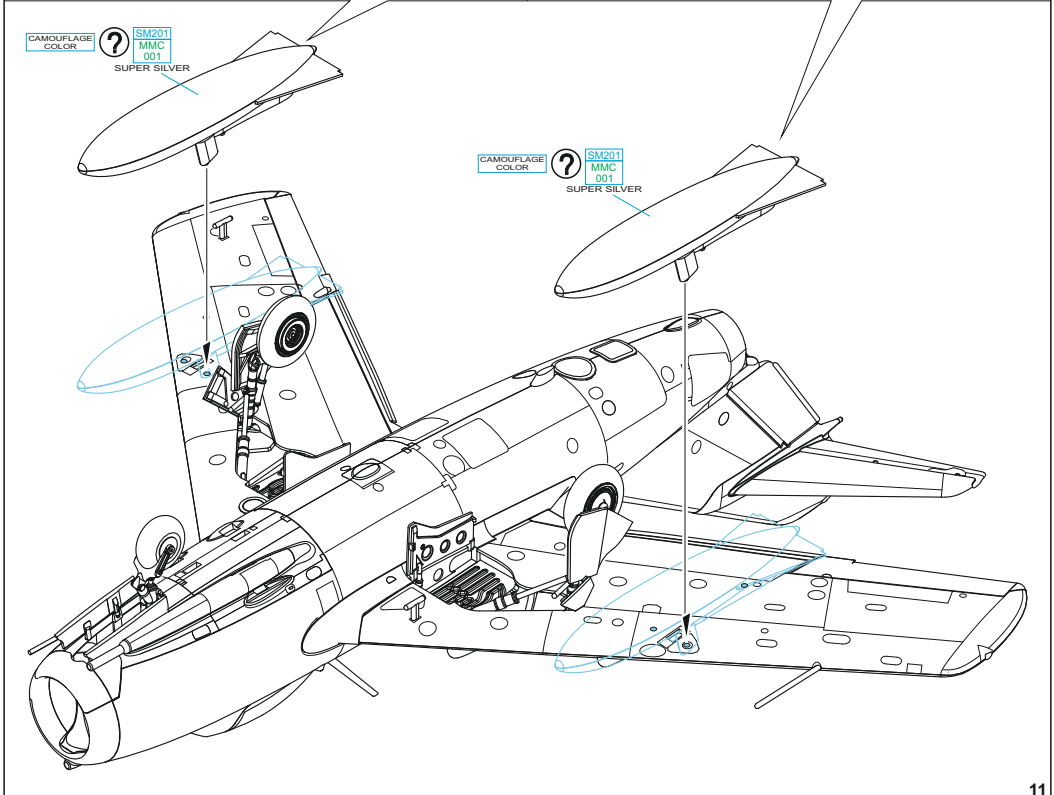
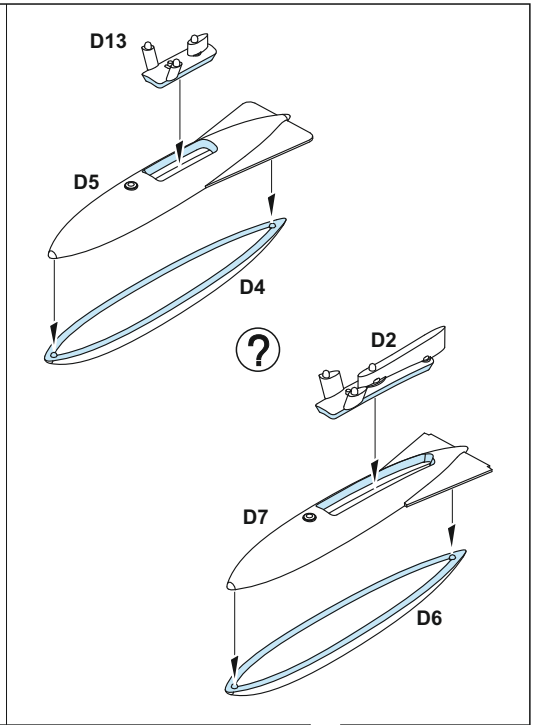
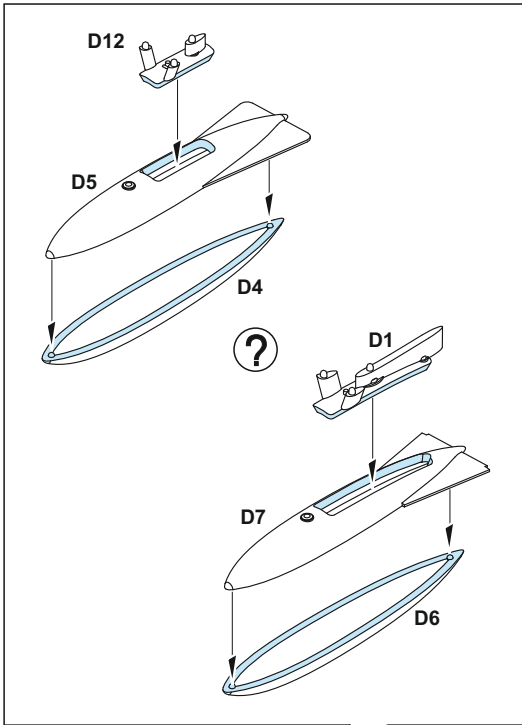

A flown by Maj. Mikhail Ivanovich Mikhin, 518th IAP, North Korea, May 1953

Mikhail Mikhin was born on October 25th, 1923 and right after the graduation from the high school he started his pilot training finishing it in the end of 1944. He did not manage to participate in any combat during the World War Two, however he participated in the air combat over Korea where he was deployed in July 1952 with the entire 518. IAP. The unit remained in the combat zone until the end of hostilities, Major Mikhin shot down 9 enemy aircraft in total (7 x F-86, 2 x F-84) for which accomplishment he was awarded the title Hero of the Soviet Union on July 14th, 1953. He remained in the active service of the Red Army Air Force after the Korean War and retired with the rank of Major General in 1980. He passed away on March 25th, 2007 in St. Petersburg.

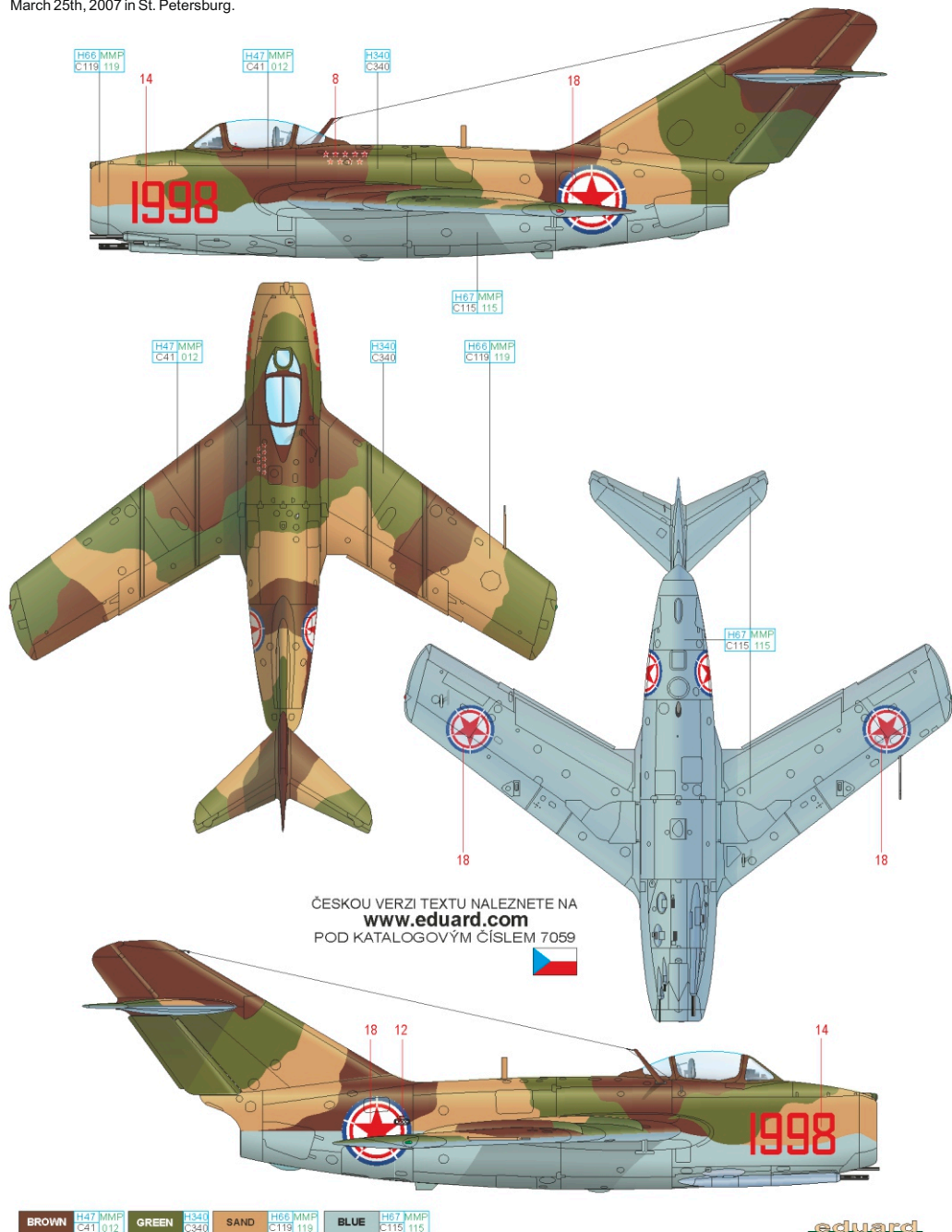

B c/n 613234, flown by kpt. Oldřich Paldus, 15. slp, Cottbus Airfield, German Democratic Republic, August 30th, 1957

A group of three MiG-15bis from 15th FR, Zatec Air Base, took part in the 2nd Cultural and Sport Celebration that was organized in Cottbus, German Democratic Republic in late August, early September, 1957. The distinctive blue marking was applied on these aircraft especially for this event. During the display, a tragedy nearly occurred when MiGs 3234 and 3233 collided in mid-air. 3234 lost the tip of its left horizontal stabilizer, but the pilot managed to maintain control over the aircraft till he could set it down. Two of pilots of this display team, Oldřich Paldus and Vaclav Polasek headed to 11th FR in 1958, when 15th FR was disbanded. In 1959 Capt. Jaromir Palecny joined them – all three pilots were not tall at all, so the team was unofficially dubbed 'Trio Prckos' ('The Three Squirrels' in English).

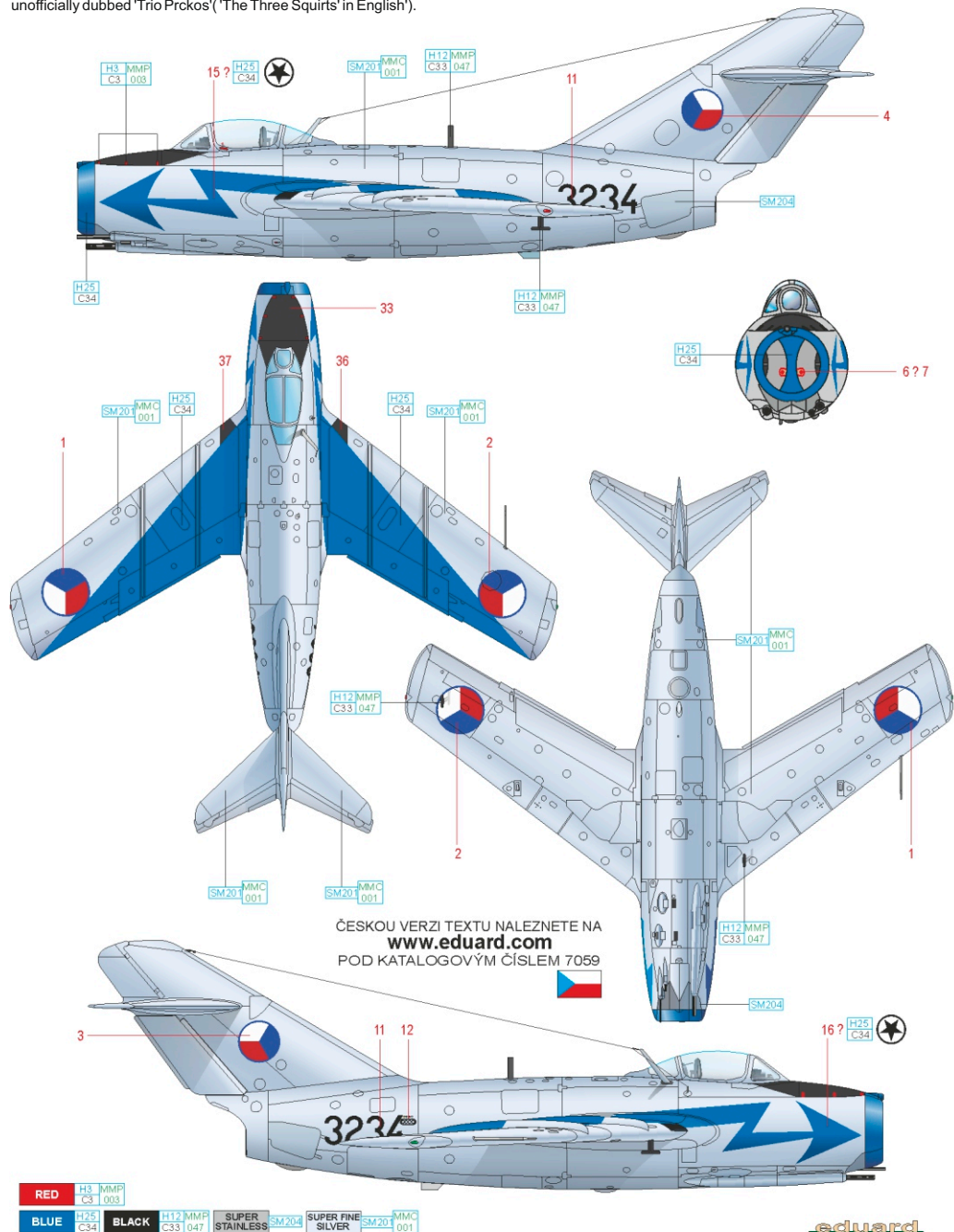

ČESKOU VERZI TEXTU NALEZNETE NA
www.eduard.com
 POD KATALOGOVÝM ČÍSLEM 7059



This Mig was delivered together with another 29 aircraft in April 1962. These originally served with the Soviet Air Force and after the overhaul were supplied in the natural metal finish to Hungary. During the overhaul the aircraft c/n 0320138 had the upgraded wing installed featuring the landing light located at the left wheel well. The light was later covered with a sheet aluminum. In August 1968 this particular airplane participated in the Warsaw Pact armed forces invasion (except Romania and Albania) to, at that time, Czechoslovakia. Before the invasion it was marked with the red stripes which were later deleted. In March 1970 the aircraft was overpainted in the camouflage colors including all stencils. In September 1975 the airframe was struck off charge having logged 1535 flight hours and was abandoned at the Szolnok airbase.

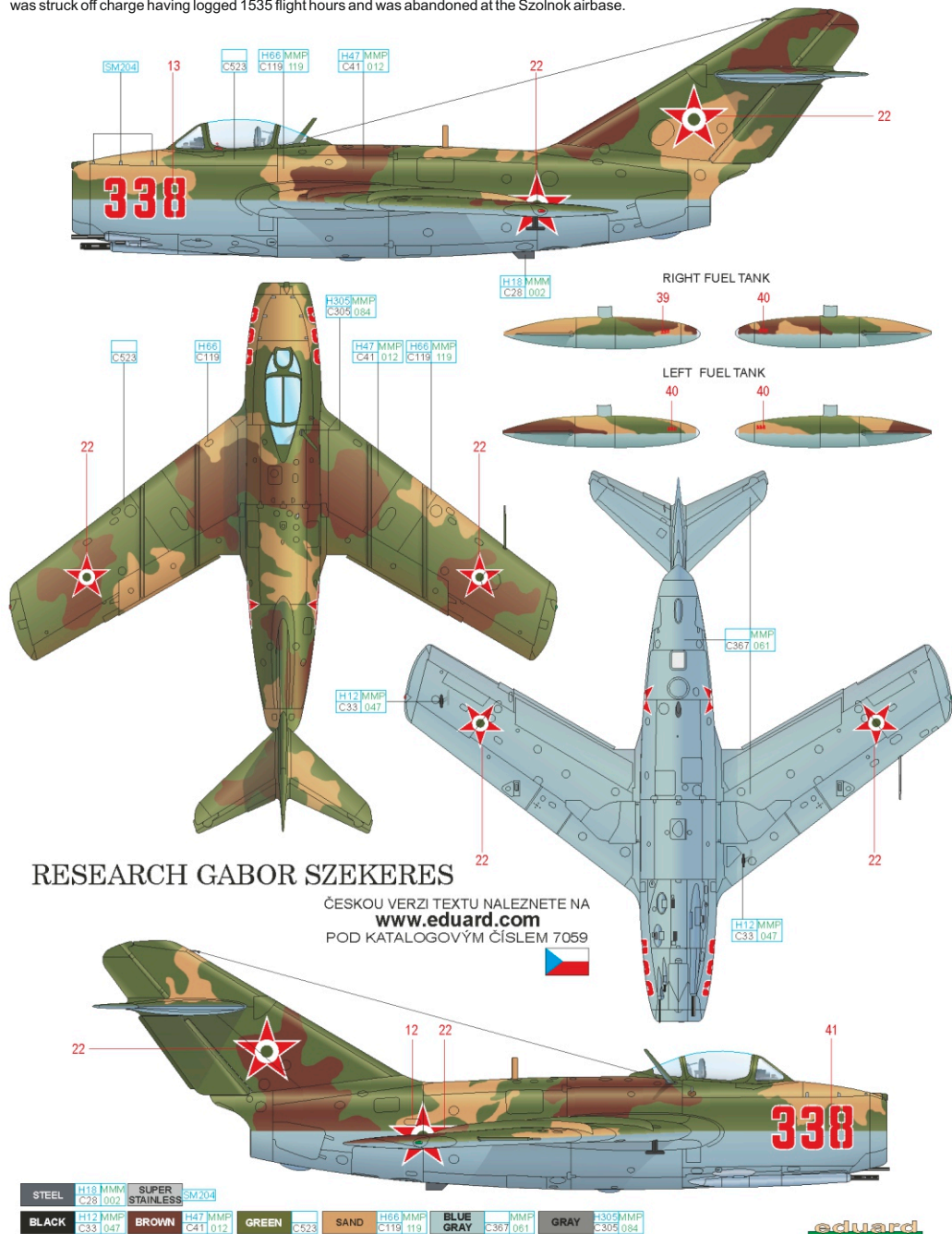

D No. 20 Squadron, Egypt., Late 50s / Early 1960s

Egypt purchased a total of 110 MiG-15bis aircraft from Czechoslovakia. This particular aircraft served with No. 20 Squadron of the United Arab Republic Air Force. The United Arab Republic was a federation of Egypt and Syria that lasted from 1958 to 1961. Egypt kept this name till 1971. No. 20 Squadron was based at Deversoir, El Qabrit and Inshas air bases.

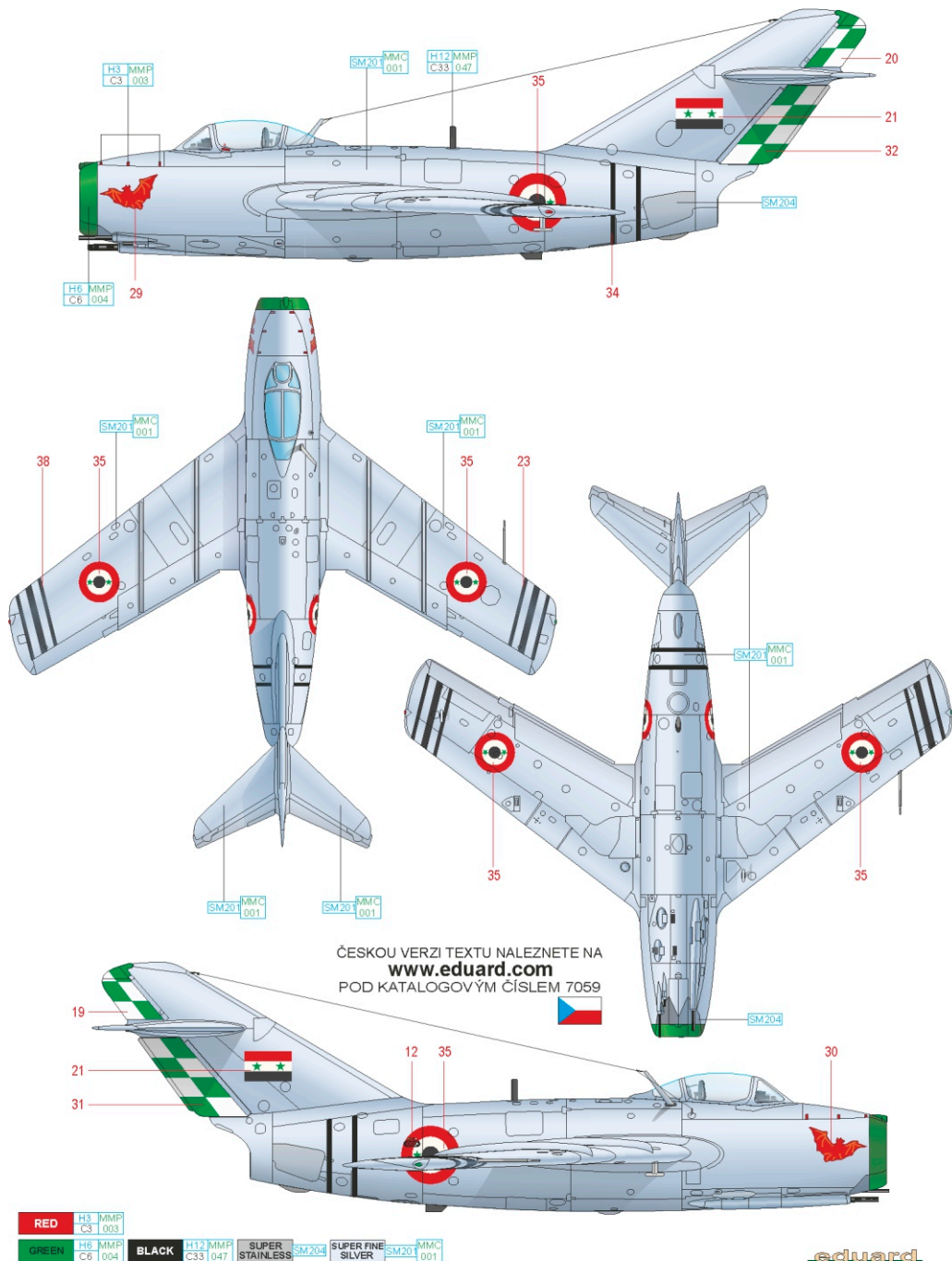

This MiG formerly took part in the Korean War – the communist attempt to occupy the entire Korean peninsula. It wore red number '1976' on its fuselage. Back in the USSR, it was simply overpainted with the yellow 30, as well as replacing the North Korean national insignia. The North Korean national insignia was simply an extension of the Soviet red star, removing the white outline and adding the red and blue circles. Based on photographic evidence, the insignia was applied on the fuselage only. It is possible these were painted on the lower surface of the wings as well.

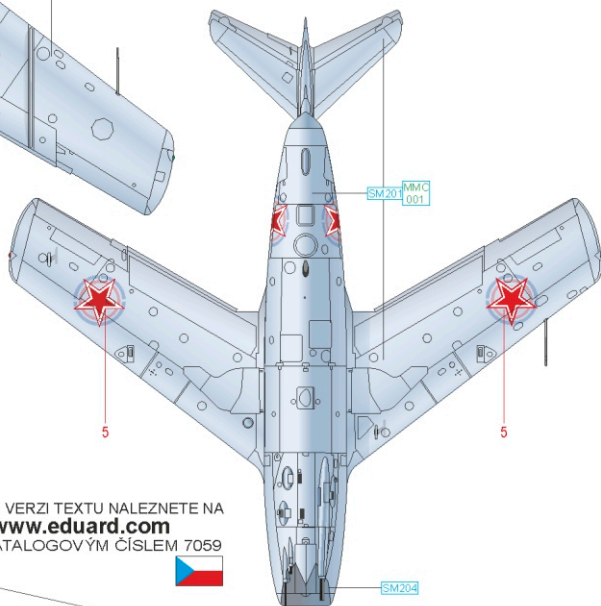
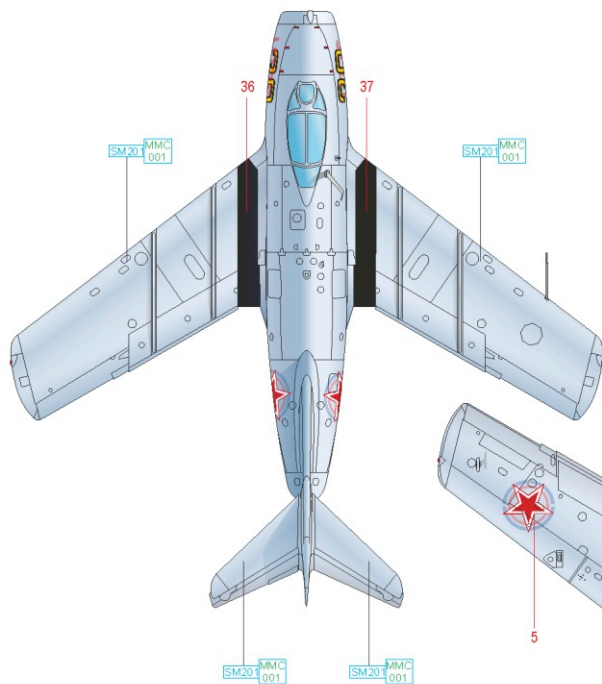
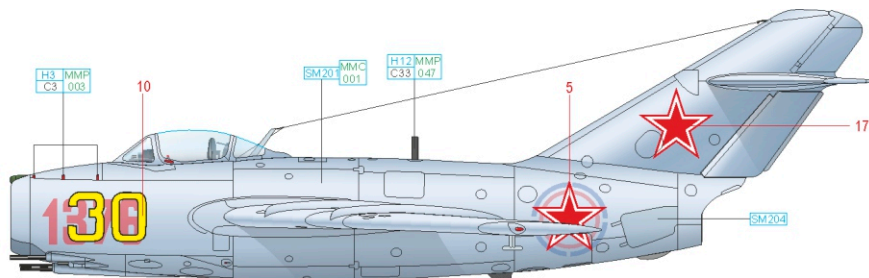

ČESKOU VERZI TEXTU NALEZNETE NA
www.eduard.com
 POD KATALOGOVÝM ČÍSLEM 7059

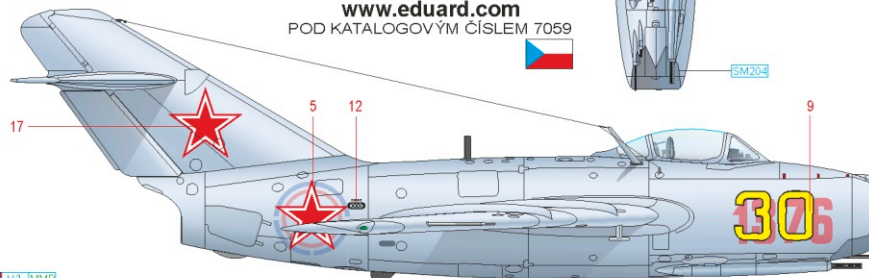

RED	H3 MMP C3 003	SUPER STAINLESS	SM204	SUPER FINE SILVER	SM201 MMC 001
BLACK	H12 MMP C33 047				

MARKING B ONLY

Leveling points

1

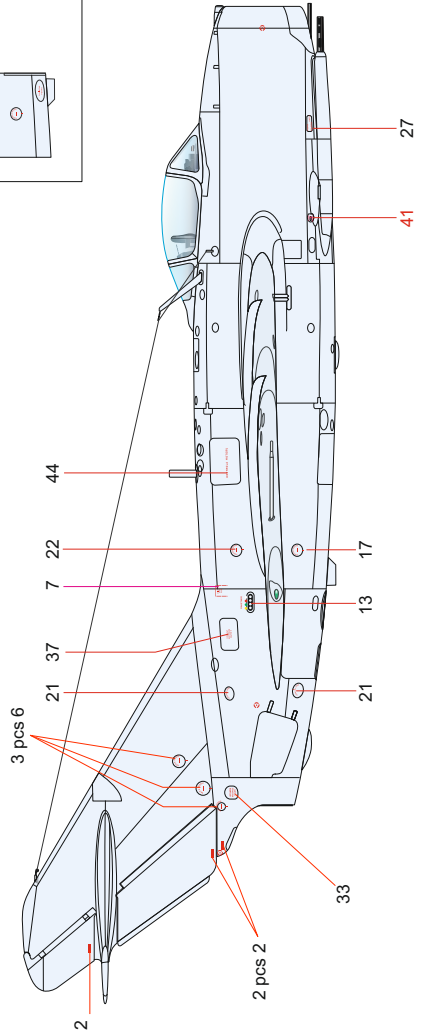
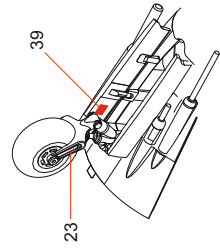
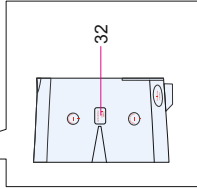
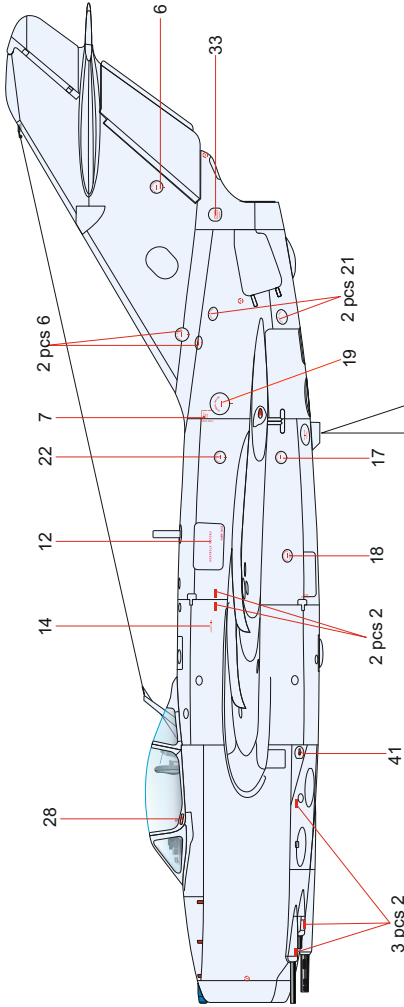
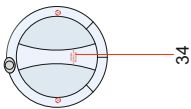

MARKING **B** ONLY

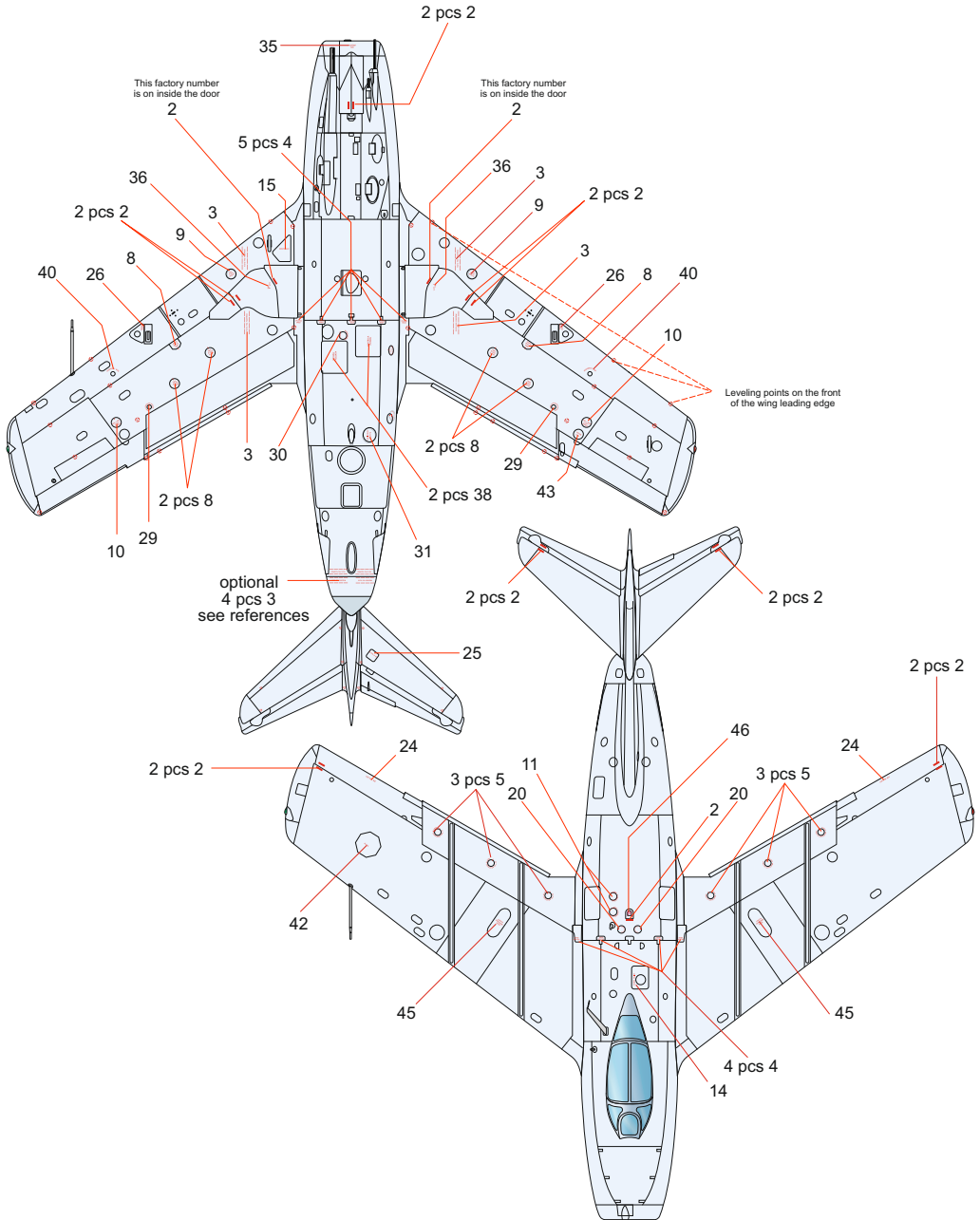

MARKING  ONLY

Leveling points

1 

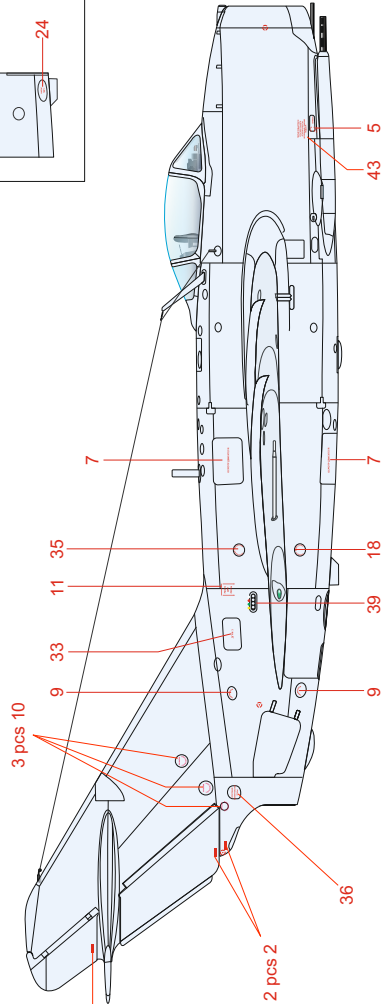
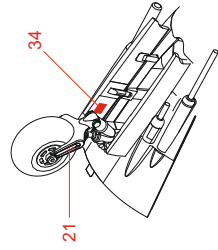
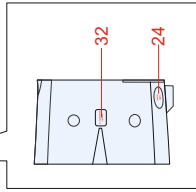
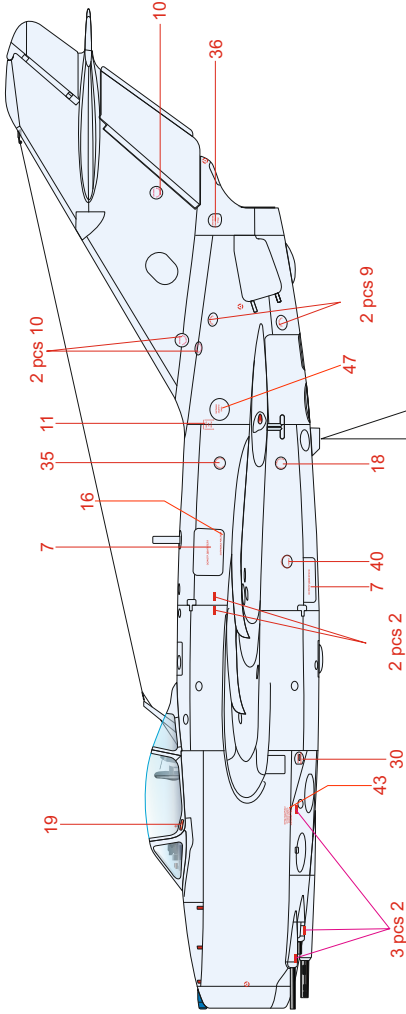
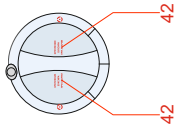

MARKING ONLY

