

A FEW WORDS FIRST

One of the most popular and best known Russian aircraft ever built was born in 1933. On the last day of that year, on December 31, the famous Soviet aviator Valerij Chcalov conducted the maiden flight of the new CKB-12 prototype. The CKB-12 was a very modern and revolutionary design at the time. The installed powerplant was a Shvetsov M-22 engine (a license built Bristol Jupiter) rated at 480 hp, instead of the anticipated Shvetsov M-25 engine giving 750 hp. That was a Soviet license built Wright 1820 Cyclone. Although the new aircraft was a bit underpowered, Chcalov was amazed with its flight capabilities and especially its sensitivity of control. The second prototype was outfitted with an imported original Wright Cyclone engine, and the aircraft performance greatly improved. After necessary development and improvements, serial production was ordered at Zavod 39 in Moscow and at Zavod 21 in Gorki under the VVS (Soviet Air Force) designation I-16. These aircraft were equipped with the M-22 engine, because the new M-25 powerplant was not yet available, and no weapons were installed. Maximum speed of these first I-16s was 362 km/h at sea level and 346 km/h at 3000 m. Fifty aircraft were manufactured at Zavod 39, known as I-16 without any additional suffix designation. Zavod 21 produced the first batch of I-16, though with some difficulties, because three other aircraft types were on their production lines. For this reason, Zavod 21's I-16 were suffixed as „Type 4“. In late summer, 1934, the first aircraft reached VVS units. Reception of the new aircraft was cool, to put it gently. The flight characteristics were very different from the operational biplanes then in service; control was overly sensitive, and the landing speed too high with a lack of frontal view due to the wide nose. The lack of landing flaps, compensated for by the downward deflection of the ailerons acting as flaps on landing, didn't made the landing any easier. Accident rates soared to unacceptable levels, and reached the point where units couldn't achieve operational status. At this time, five NII VVS (Air force research institute) pilots, Kokkinaki, Suprun, Preman, Evseev and Shevchenko, made a tour of air force bases. With their red painted I-16, they demonstrated the aircraft's performance and potential. At about the same time, in late Spring, 1935, M-25 engine was finally available in sufficient quantities, and the development of the I-16 with its originally planned engine, was finally completed. The new engine received a new Watter type cowling, giving the I-16 its characteristic shape. The flight characteristics were unchanged, but the performance significantly improved. The maximum speed was now 390 km/h at sea level, and 445 km/h at 3 000m. The aircraft was now armed with two 7,62 mm ShKAS machine guns mounted in the wings. By January 1936, the Type 5 replaced the Type 4 on the production lines at Zavod 21, and in late spring entered service with VVS units. Still a fresh newcomer on the fighter scene, the I-16 Type 5 soon got the chance to show their stuff in a real fight. Two flights of I-16s were dispatched to Spain to help the Republican forces. During the Spanish Civil War, the I-16 built its great warrior reputation, named Mosca by Republican pilots, but it was their opponent's nickname that became better known, giving the I-16 the best known identifier - the „Rata“. Until 1938, the Type 5 remained as the main version, marginally updated to the Type 6, but it is not certain if this was an official designation. Besides Spain, the Type 5 saw combat over China, where these aircraft were sent along with Soviet crews. By 1937, initial troubles were forgotten, but new critics were found. Problems with poor quality of the perplex canopy nagged on, and two machine guns became insufficient, especially in combat with modern bombers. Therefore, the new and improved Type 10 was introduced, instigating some significant changes. First, the new M-25V 750 hp engine was installed. The wing was re-designed to include landing flaps. Two 7,62 mm ShKAS machine guns were added on top of the engine, with two corresponding fairings on the engine cowling. The cockpit was improved, and the canopy was completely redesigned, with an all-glass single piece windscreen ahead of a now open cockpit. The Aldus OP-1 telescopic gun sight was replaced with new reflector type, the PAK-1. The wing was later modified to provide for retractable landing skis. Maximum speed was 390 km/h at sea level and 438 km/h at 3200 m. The Type 10's production started at Gorki in March, 1938. The Type 10 reached Spain as well as China, and fought against the Japanese over Chalkin-Gol and Chasan Lake. They saw action in the Winter War against the Finns, and also fought in Poland in the Autumn of 1939. In June, 1941, when the USSR was attacked by Germany and the Great Patriotic began, the I-16 Type 10 remained, along with other I-16 versions, the main weapon of VVS fighter units.

The Type 10 formed the basis for the up-gunned Type 17. The wing machine guns were replaced by two 20 mm ShVAK cannon in late 1938, and production was set for October of the same year. Further I-16 development came in the form of new engine installation, when the M-62, rated at 800 hp was mated to the airframe. A new AV-1 propeller was also introduced, which required a new, remarkably wide, spinner. The maximum speed was increased to 411 km/h at sea level and 460 km/h at 3200 m. The next version was the Type 24. A modified M-63 engine of 930 hp was used, the radio was added as standard equipment, and the wing and undercarriage were strengthened as well. Thanks to a higher weight, maximum speed was now at 408 km/h (some sources indicate 440 km/h) and 460 km/h at 4700 m (489 km/h by some sources). The I-16 Type 24 entered service in November, 1939, and became the main production version in 1940. It is believed that most I-16s on the front lines in June, 1941, were Type 24s. The final version was the Type 29, in 1940. To reduce weight, the weapon load was reduced to three machine guns, when the two wing weapons were removed, and a third, in this case the 12,7 mm UBS, was mounted under the engine in the belly of the aircraft. The wing was completely redesigned, increasing the metal plated area to the full bottom surface of the wing. The bomb/external fuel tank racks were installed under the wing, and also rocket rails became standard. It seems that the future I-16 role was expected to be that of fighter-bomber, because new, modern fighters were ordered into service in early 1941. Nevertheless, during the early years of the Great Patriotic War, I-16s of all versions played their part extremely well. In 1942, they remained an important force. The early teething troubles were definitively over, and the I-16 took on the role of the 1934-era biplane fighters. The I-16 became well liked by pilots and crews alike, and were viewed as reliable types. Most I-16s were produced during the pre-war years, and the quality was much higher than of the new fighters, which were hampered by production under wartime conditions. Nevertheless, the time of the I-16 was over by late 1942, the technical and performance superiority of their opponents became too high, and the I-16 withdrawal from frontline service was just a question of time. But, they remained in service even as late as 1943. Although the nomenclature of the I-16 lineage looks as though the types were produced in a chronological order, it was quite different in reality. Production was mixed, and different types were on production lines together. Production of the Type 5 continued even when the Type 24 was being manufactured. In 1941, the types were also mixed within the front line units. Perhaps this is one of the reasons, why there is so much confusion surrounding the subtyping of the I-16. In total some 9450 I-16s of all versions were produced, most of them, to the tune of 8495, by Zavod 21 at Gorki.

TECHNICAL SPECIFICATIONS:

Wing span: 9.00 m, Length: 6.07 m

Empty weight: 1548 kg

Take-off weight: 1914 kg

Speed: 418 km/h at sea level,

468 km/h at 4480 m

Time to 5000 m: 5,8 min

Initial rate of climb: 17,4 m/sec

Service ceiling: 9 800 m

Engine: one M-63 rated at 930/1100 hp

Weapon: 2xShKAS 7.62 mm machine guns

(Data: Erik Pilawskii, SOVIET AIR FORCE

FIGHTER COLOURS 1941-1945)

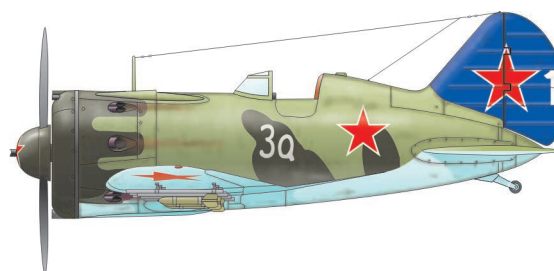

ATTENTION



UPOZORNĚNÍ



ACHTUNG



ATTENTION



注意



Carefully read instruction sheet before assembling. When you use glue or paint, do not use near open flame and use in well ventilated room. Keep out of reach of small children. Children must not be allowed to suck any part, or pull vinyl bag over the head.



Před započatím stavby si pečlivě prostudujte stavební návod. Při používání barev a lepidel pracujte v dobře větrané místnosti. Lepidla ani barvy nepoužívejte v blízkosti otevřeného ohně. Model není určen malým dětem, mohlo by dojít k požití drobných částí.



lire soigneusement la fiche d'instructions avant d'assembler. Ne pas utiliser de colle ou de peinture à proximité d'une flamme nue, et aérer la pièce de temps en temps. Garder hors de portée des enfants en bas âge. Ne pas laisser les enfants mettre en bouche ou sucer les pièces, ou passer un sachet vinyle sur la tête.



Von dem Zusammensetzen die Bauanleitung gut durchlesen. Kleber und Farbe nicht nahe von offenem Feuer verwenden und das Fenster von Zeit zu Zeit Belüftung öffnen. Bausatz von kleinen Kindern fernhalten. Verhüten Sie, daß Kinder irgendwelche Bauteile in den Mund nehmen oder Plastiktüten über den Kopf



組み立てる前に必ず説明書をお読み下さい。接着剤や塗料をご使用の際は、窓を開けて十分な換気をおこない、火のそばでは使用しないで下さい。小さな子供の手の届かない所に必ず保管してください。部品や破片を噛んだり、なめたり、飲んだりすると大変危険です。又、部品を取り出した後のビニール袋は、小さな子供が頭から被ったりすると窒息する恐れがありますので、破り捨てして下さい。

INSTRUKTION SIGNS * INSTR. SYMBOL * INSTRUKTION SINNBILDEN * SYMBOLES * 記号の説明



OPTIONAL
VOLBA
FACULTATIF
NACH BELIEBEN
選択する



BEND
OHNOUT
PLIER SIL VOUS PLAIT
BITTE BIEGEN
折る



OPEN HOLE
VYVRTAT OTVOR
FAIRE UN TROU
OFFNEN
穴を開ける



SYMETRICAL ASSEMBLY
SYMETRICKÁ MONTÁŽ
MONTAGE SYMÉTRIQUE
SYMMETRISCHE AUFBAU
左右均等に組み立てる



NOTCH
ZÁŘEZ
L'INCISION
DER EINSCHNITT
切る



REMOVE
ODŘIZNOUT
RETIRER
ENTFERNEN
移す



APPLY EXPRESS MASK
POUŽIT EXPRESS MASK
AND PAINT BEFORE
GLUING

PARTS

DÍLY

TEILE

PIÈCES

部品

PLASTIC PARTS

PE - PHOTO ETCHED
DETAIL PARTS

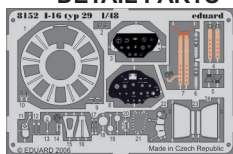

eduard
MASK

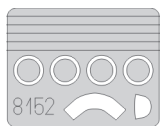

FILM



-Parts not for use. -Teile werden nicht verwendet. -Pièces à ne pas utiliser. -Tyto díly nepoužívejte při stavbě. -使用しない部品

COLOURS



BARVY



FARBEN



PEINTURE



色

GSI Creos (GUNZE)		
AQUEOUS	Mr.COLOR	
[H 3]	[3]	RED
[H 4]	[4]	YELLOW
[H 11]	[61]	WHITE
[H 12]	[33]	BLACK
[H 47]	[41]	RED BROWN
[H 61]	[35]	LIGHT GRAY
[H 67]	[115]	LIGHT BLUE
[H 77]	[]	TIRE BLACK
[H 90]	[47]	CLEAR RED

AQUEOUS	Mr.COLOR	
[H 303]	[303]	GREEN
[H 320]	[]	GREEN
[H 344]	[]	RUST
[H 94]	[138]	CLEAR GREEN
[]	[74]	LIGH BLUE
[]	[110]	BLUE
[]	[136]	GREEN
Mr.METAL COLOR		
[MC218]	[]	ALUMINIUM
[SM06]	[]	CHROME SILVER

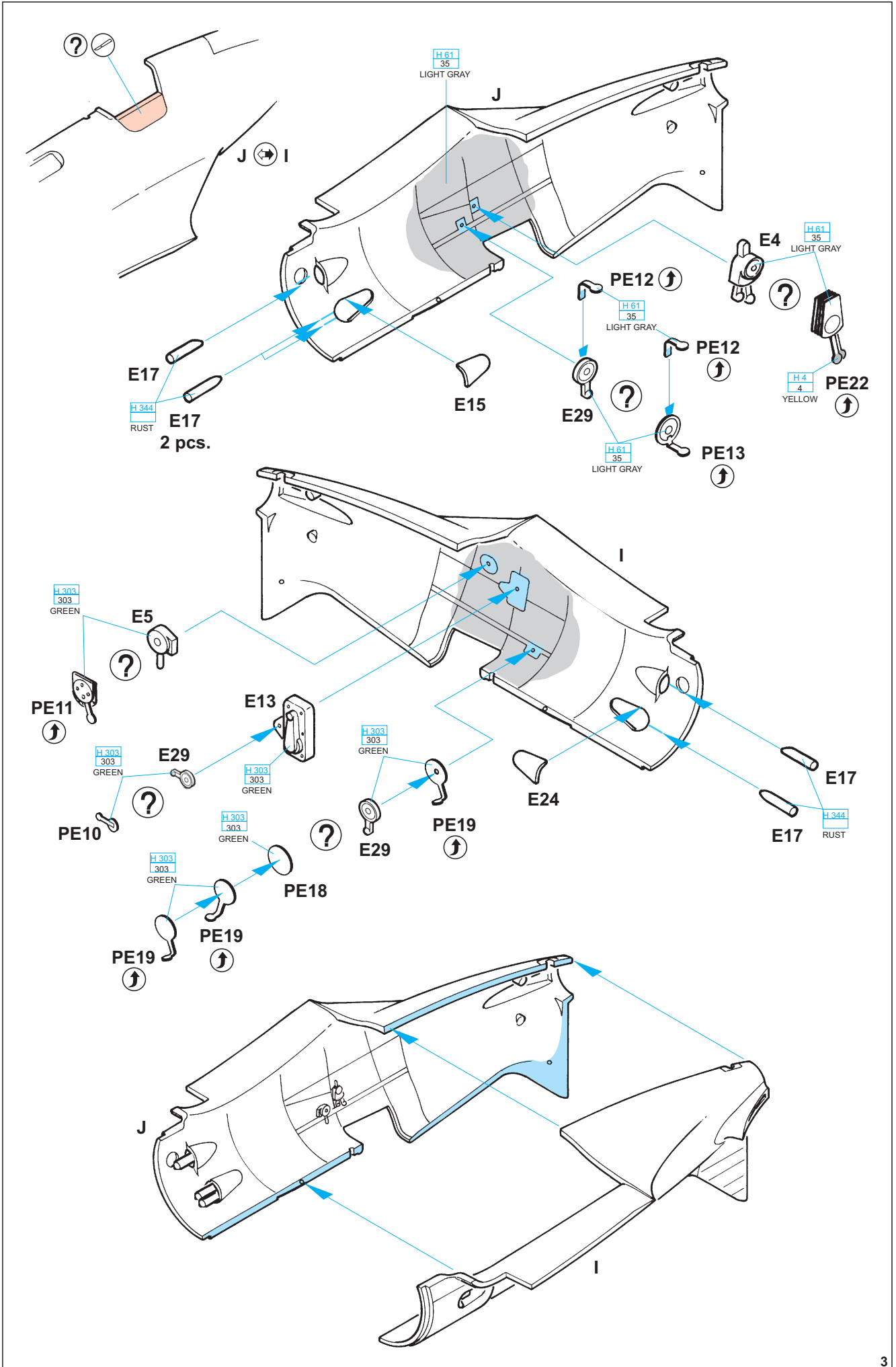

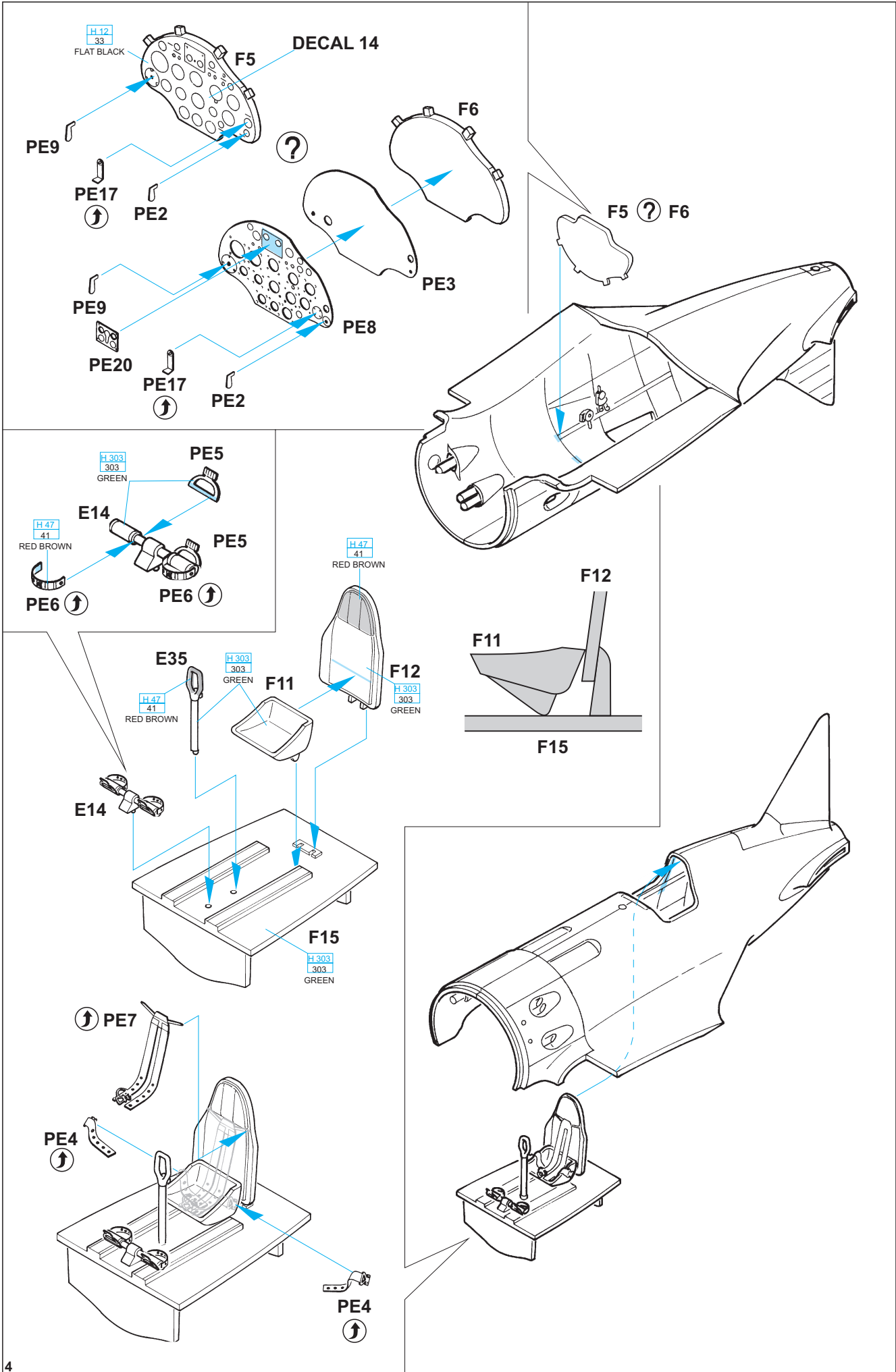

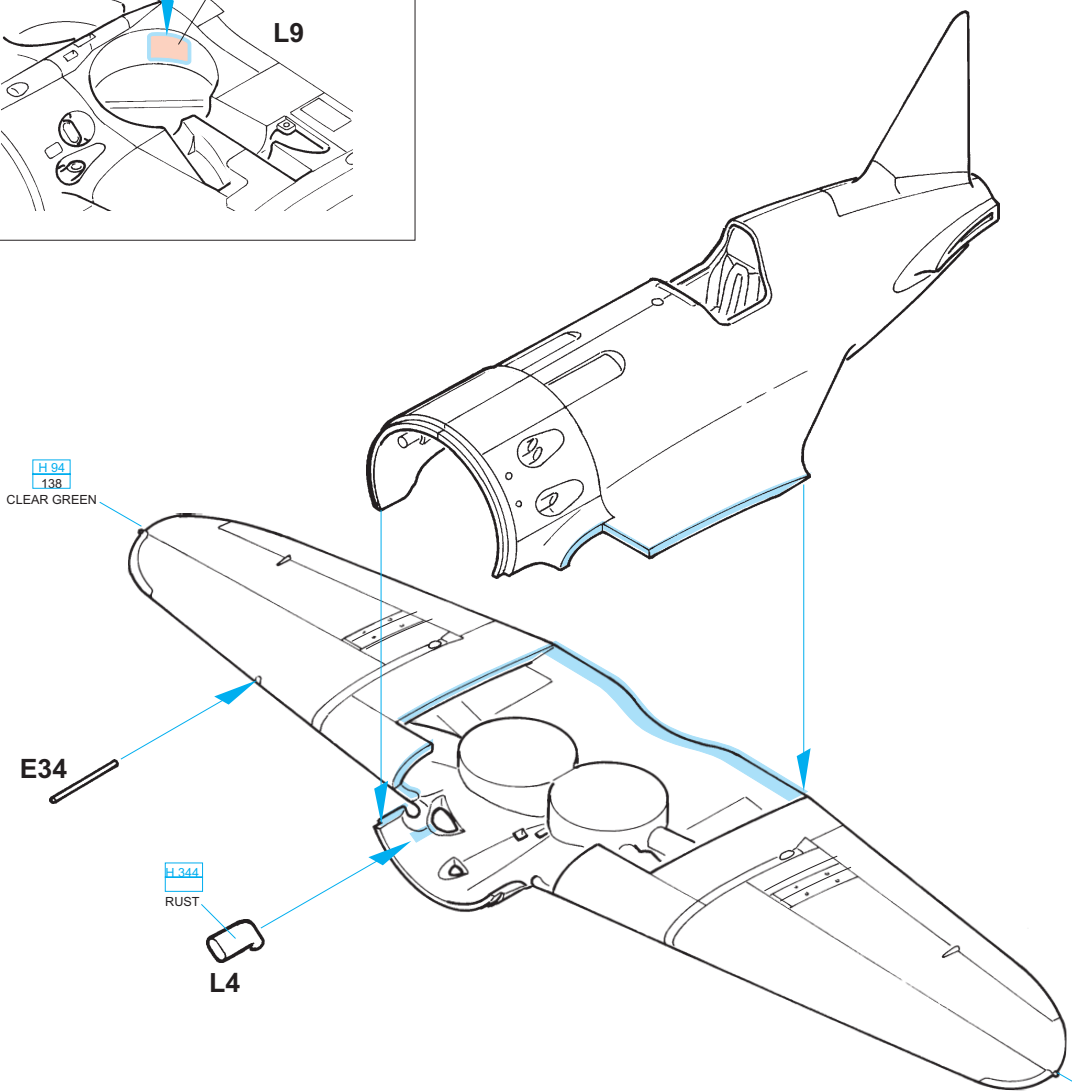
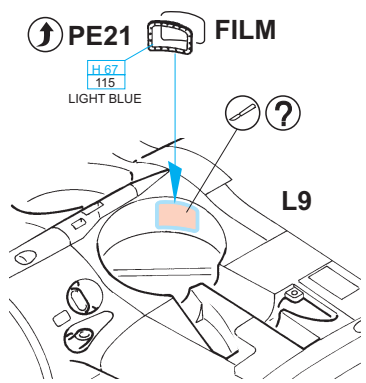
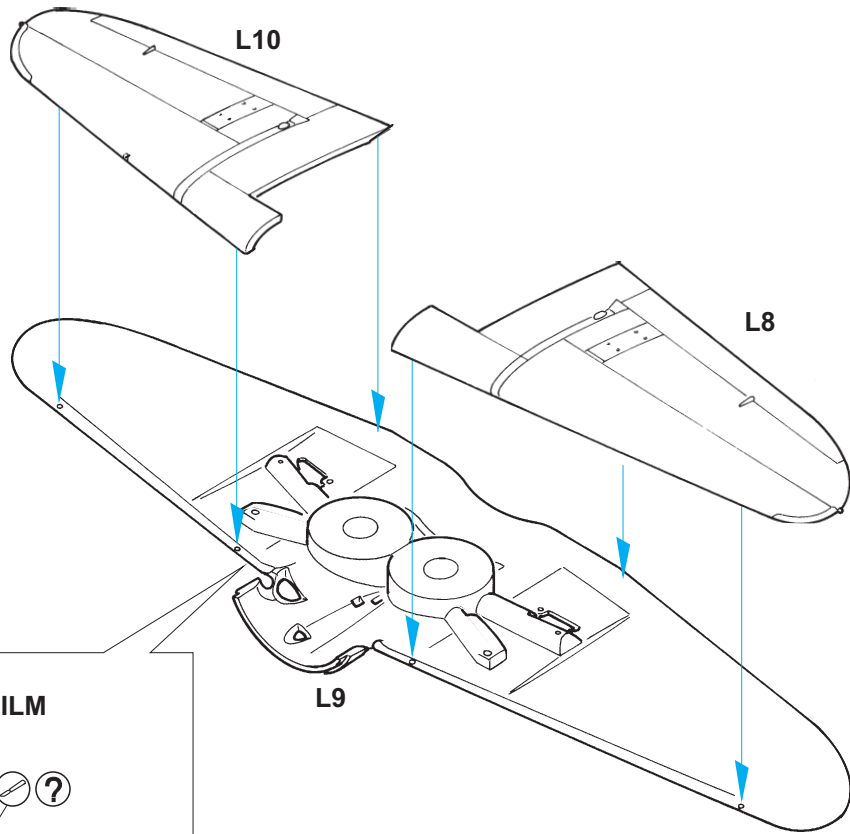

H 90
47
CLEAR RED

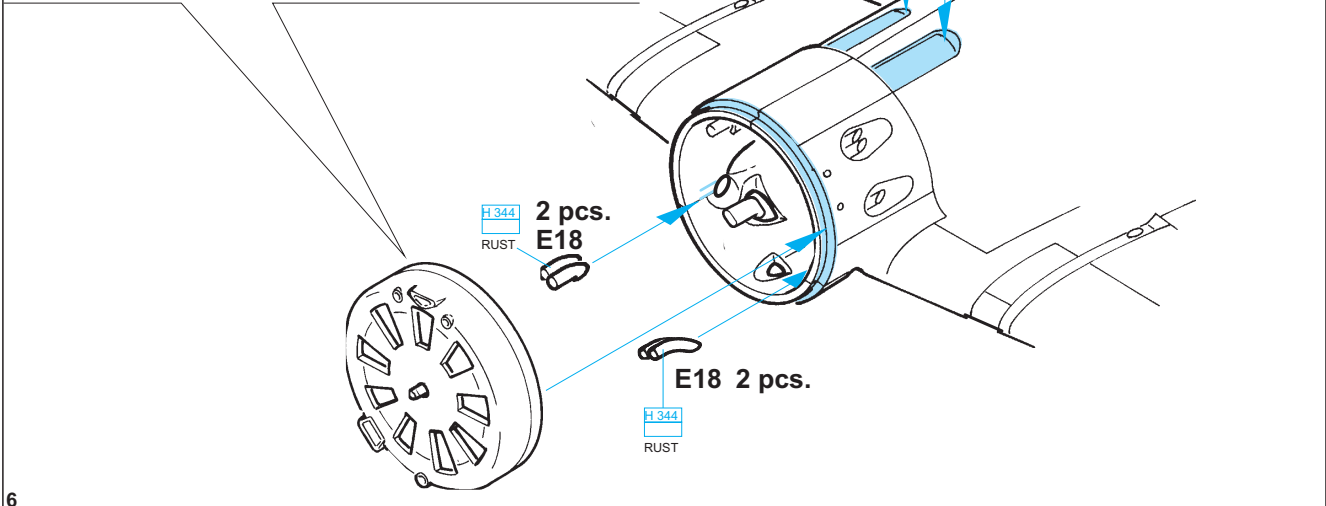
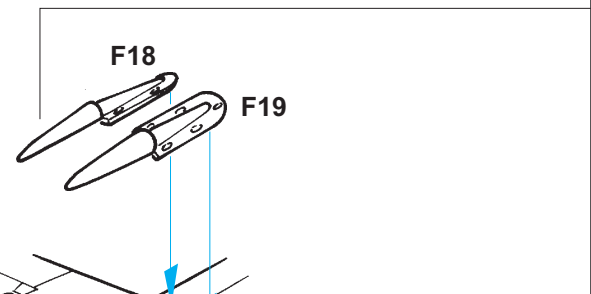
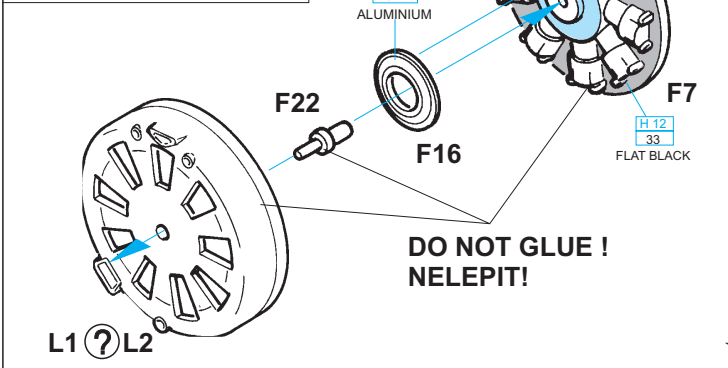
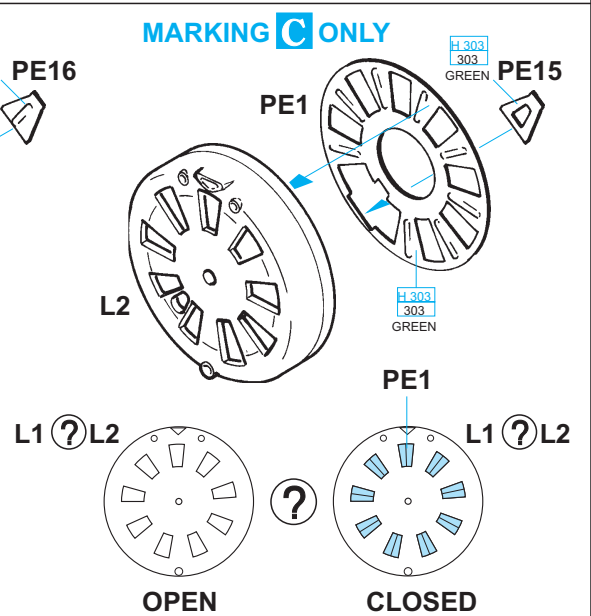
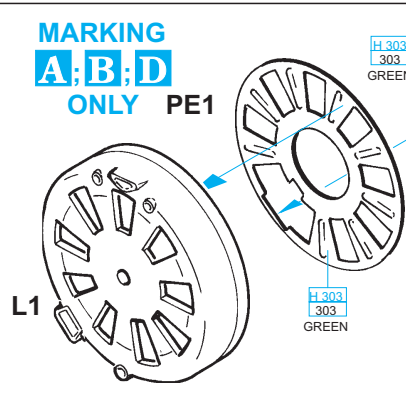
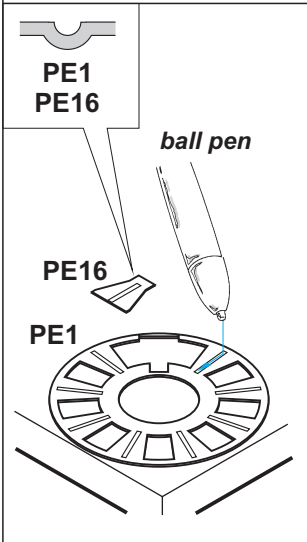
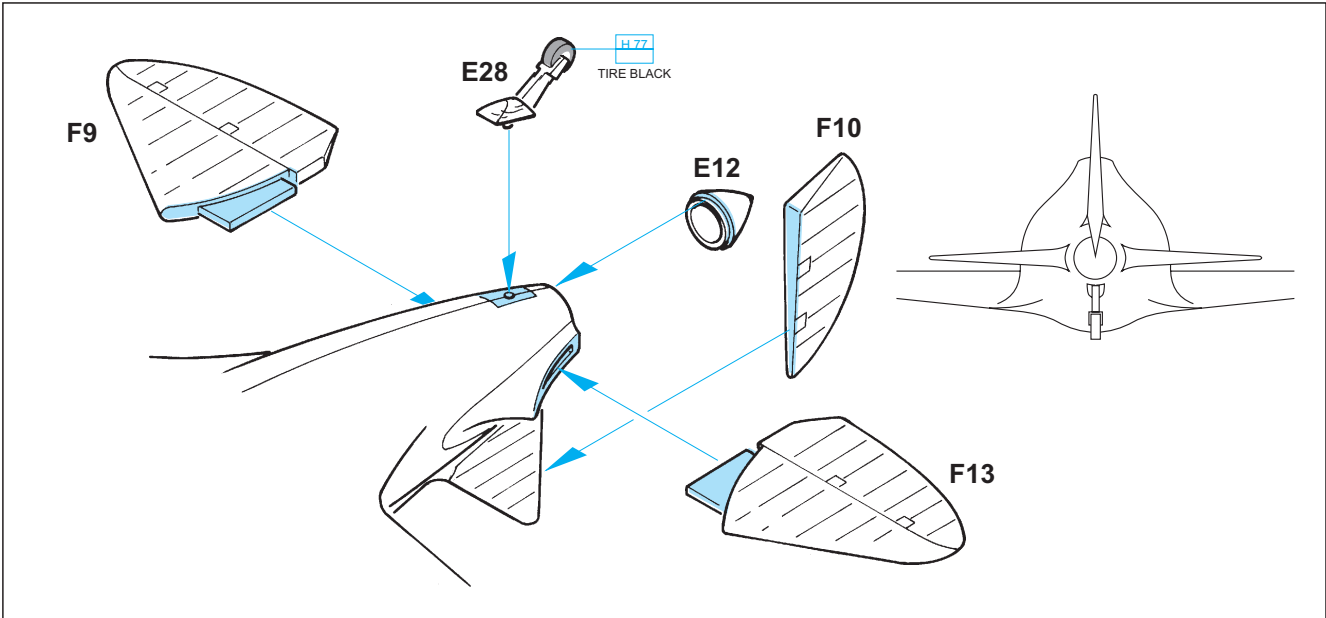

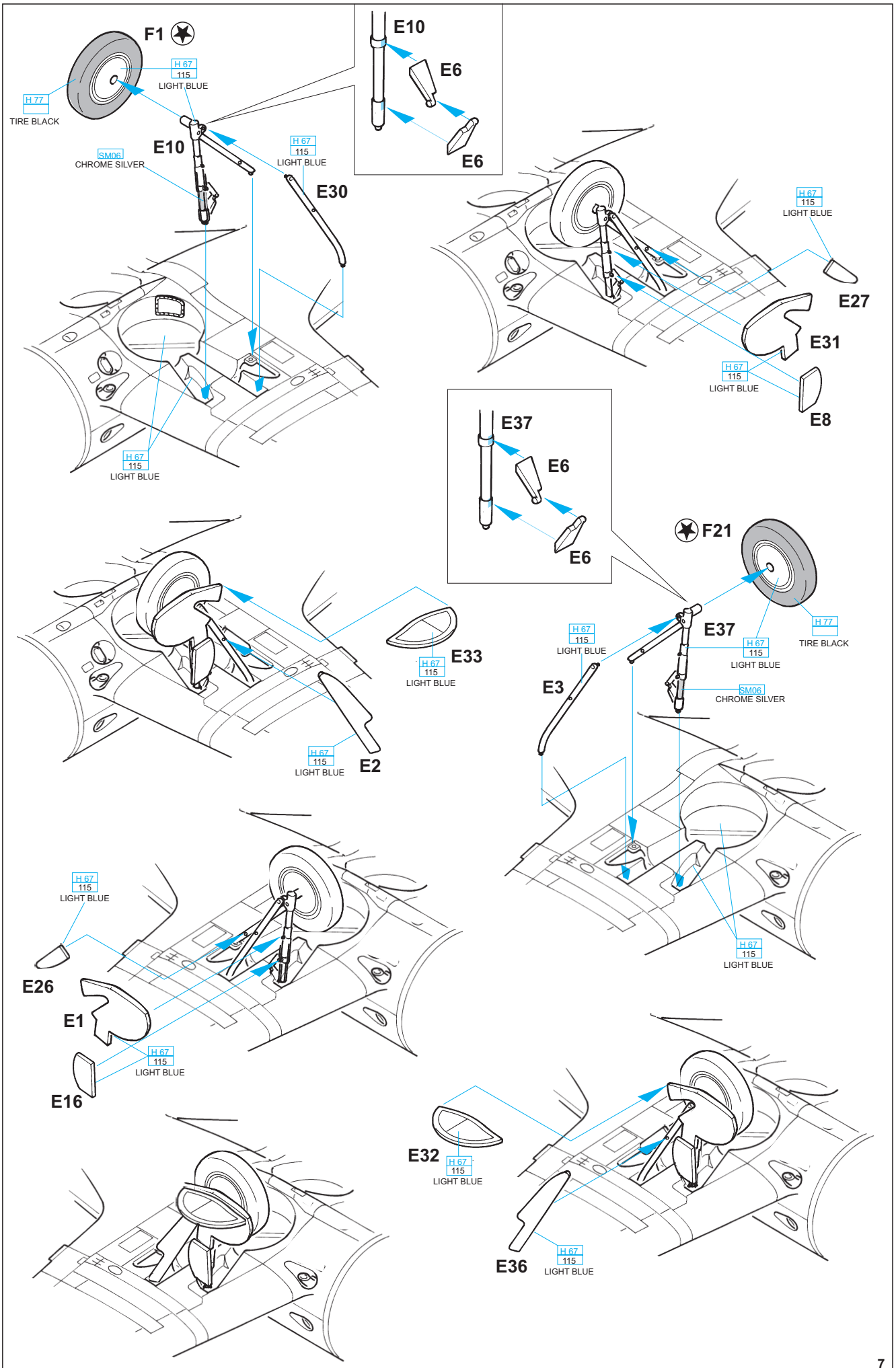

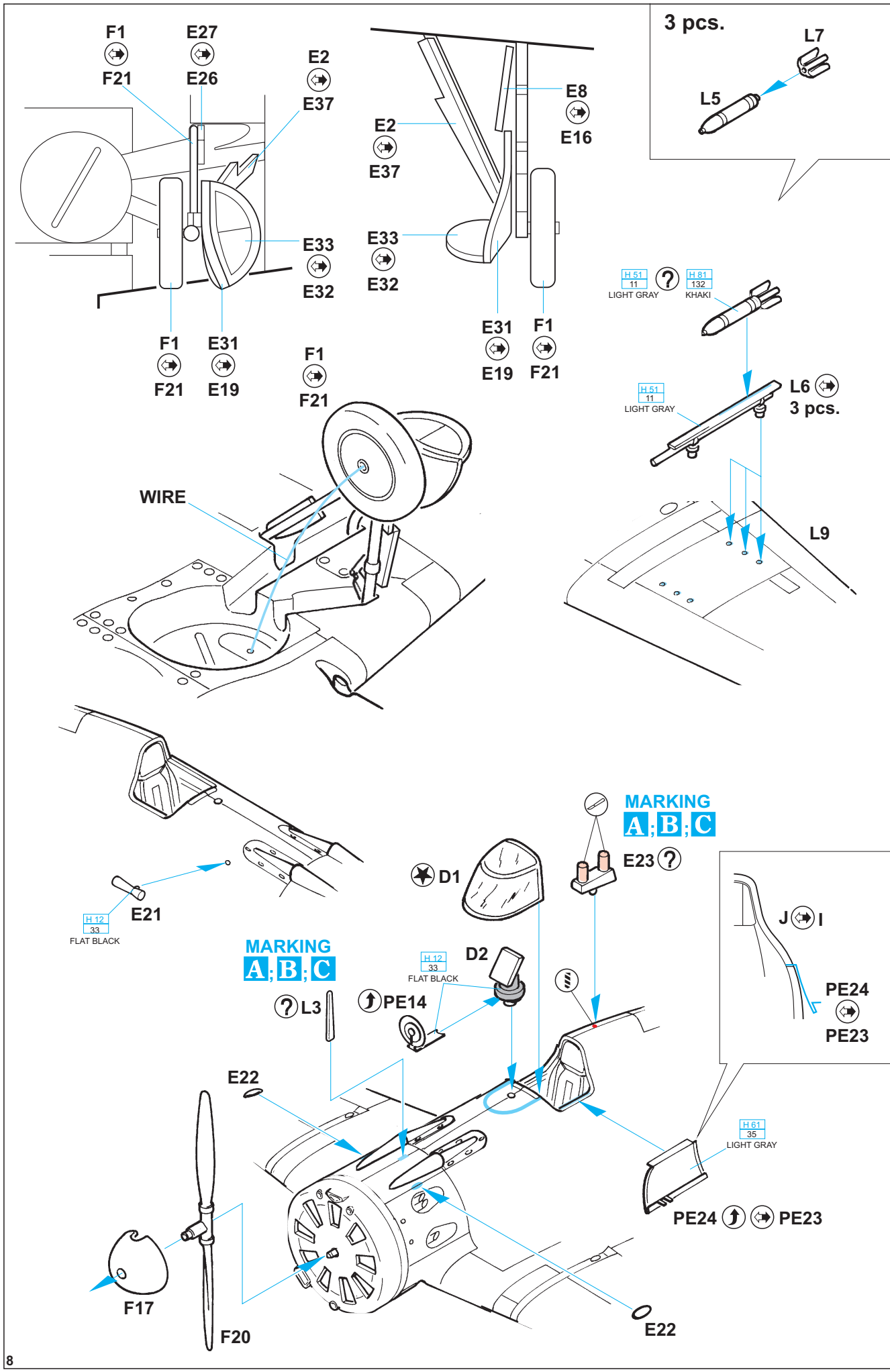

3 pcs.

L7

L5

H 51
11
LIGHT GRAY

H 81
132
KHAKE

H 51
11
LIGHT GRAY

L6

3 pcs.

L9

MARKING
A; B; C

E23

MARKING
A; B; C

H 12
33
FLAT BLACK

H 12
33
FLAT BLACK

J

I

PE24

PE23

H 61
35
LIGHT GRAY

PE24

PE23

F17

F20

E22

A 156.IAP, Winter 1941-1942

"Yellow 45" served with 156.IAP (Fighter Air Regiment) in the winter of 1941. The aircraft wears a nice example of field applied winter camouflage. The original dark green/light blue standard camouflage was augmented by a white pattern applied with MK-7 white dispersion paint. The white paint is particularly opaque; the bottom green bleeds through. The aircraft has the early type of front cowling, with a single squared bottom right-side oil cooler air intake. It is assumed that "Yellow 45" was flown by A.Pavlovskiy, a pilot of 156.IAP in winter 1941/42.

Žlutá 45 sloužila u 156.IAP (Stíhací letecký pluk) v zimě 1941. Kamufláž stroje je pěkným příkladem polní aplikace zimního kamuflážního nátěru. původní tmavě zelený nátěr vrchních ploch byl doplněn bílými poli, natřenými bílou disperzní barvou MK-7. Skrz bílý nátěr místy prosvítá původní tmavě zelená. Stroj má starší verzi čelní masky prstence motoru s jedním hranatým bočním vstupem vzduchu k olejovému chladiči. Předpokládá se, že pilotem žluté 45 byl A.Pavlovskij, jeden z pilotů pluku v zimě 1941/42.

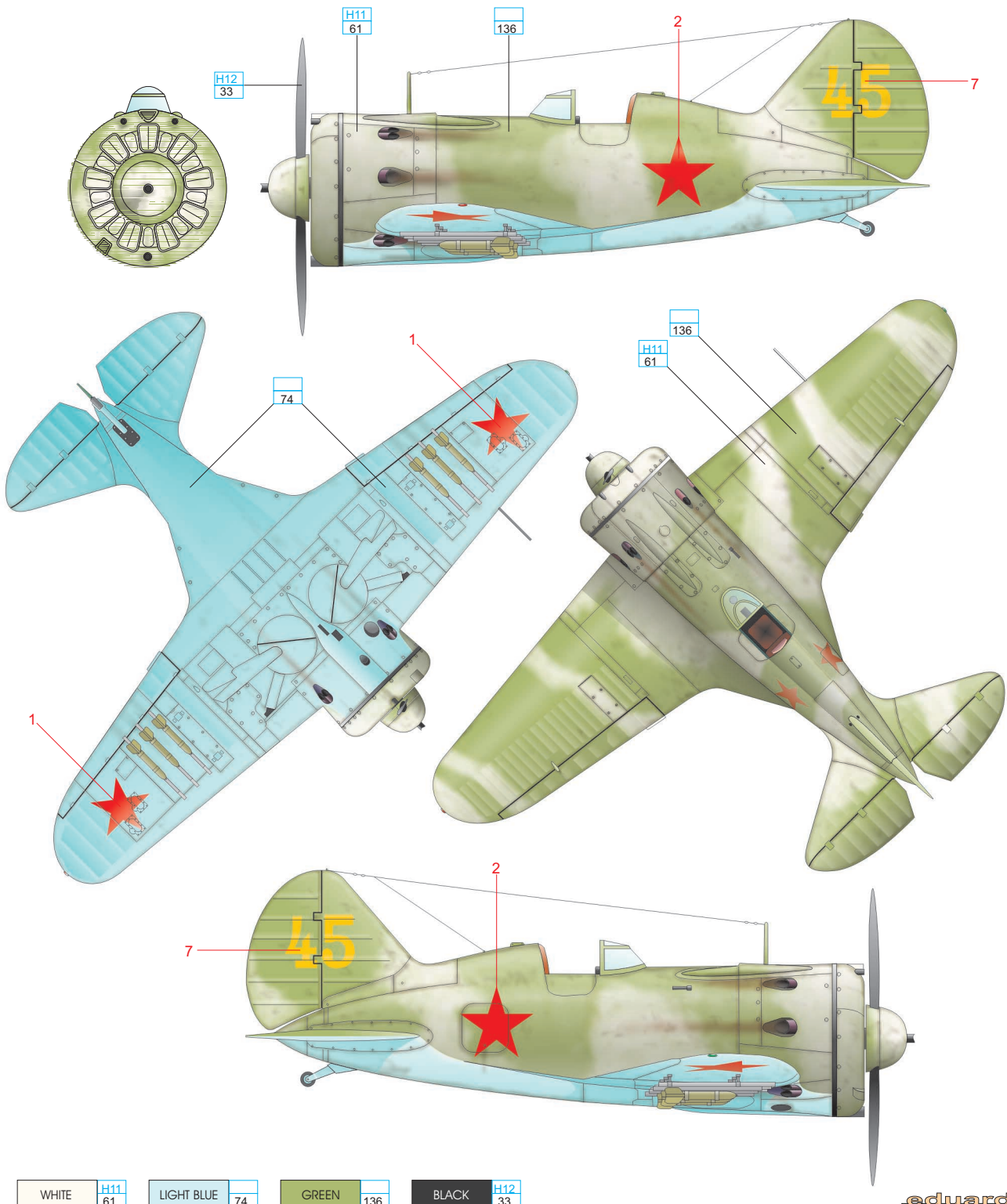

B 16.IAP, Autumn 1941

It is believed this "Red Nine" served with 16.IAP at Moscow in the tough days of fall, 1941, when the German offensive on Moscow was revved-up. The aircraft wears the standard early war (1941-1943) camouflage pattern with dark green/black upper surfaces and light blue lower surfaces. The spinner, as well as the tail tip, was painted red, and the inscription ("Death to Invaders!") was most probably yellow. No significant weathering is seen on this aircraft. The aircraft has the early type of front cowling, with the single squared bottom right-side oil cooler air intake.

Předpokládáme, že tato „Červená devítka“ sloužila u 16.IAP u Moskvy v těžkých dnech podzimu 1941, kdy začínala německá ofenzíva na Moskvu. Letoun nese standardní kamufláž sovětských letadel z let 1941-1943, sestávající z tmavě zelených a černých polí na horních a bočních plochách a světle modrých spodních ploch. Vrtulový kužel a vrchol směrovky jsou červené, nápis na boku (Smrt vetřelcům!) pravděpodobně žlutý. Stroj nenesl podstatné známky opotřebení, a má starší verzi čelní masky prstence motoru s jedním hranatým bočním vstupem vzduchu k olejovému chladiči.

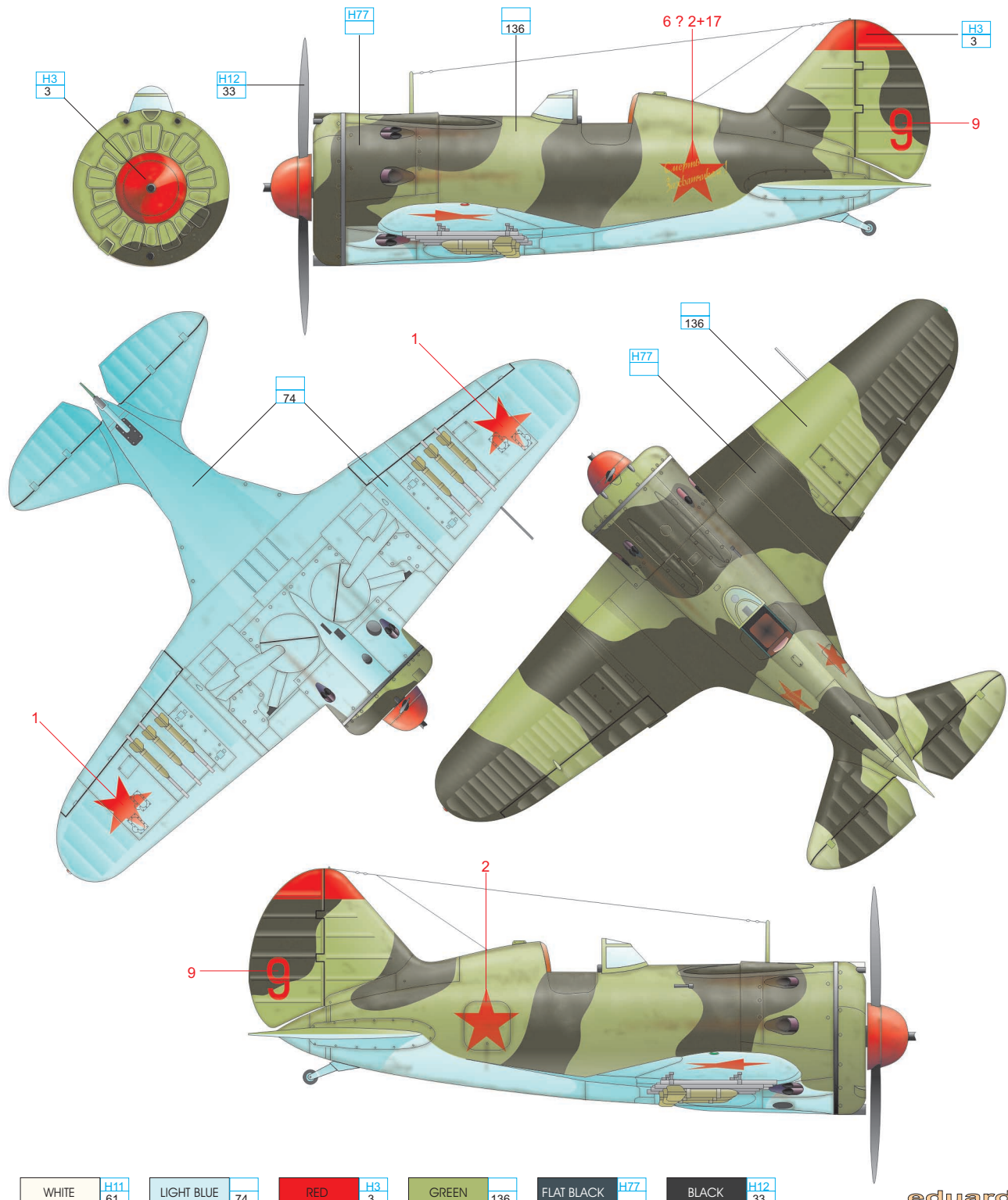

C 7.IAK-PVO, Spring 1942

"White 1" served with 7.IAK PVO (Fighter Air Corps, Air Defense) with the air defense forces of Moscow in the spring of 1942. Three pilots are known to have flown this kite, Sergeants Slesarchuk, Gazin and Perevera. It seems the black pattern was a field application over the original dark green surface. The tail is estimated to be blue, however, another color is possible. The letters on the side of the fuselage surely make up the Russian word "Za" ("for"), most probably the first word of a typical Soviet inscription such as "Za Stalina" or "Za Rodinu" ("Za CCCP" etc.). The aircraft has the late type front cowling with two right-side front oval openings of the oil cooler air intake. Four RS 132 rocket rails were mounted under the wing, two under each half. The aircraft has the late type front cowling with two right-side front oval openings of the oil cooler air intake. Four RS 132 rocket rails were mounted under the wing, two under each half.

Bílá jednička sloužila na jaře 1942 u 7. Stíhacího leteckého sboru protivzdušné obrany (7.IAK PVO) v sestavě protivzdušné obrany Moskvy. Stroj používali střídavě tři piloti, seržanti Slesarčuk, Gažin a Perevera. Zdá se, že černá pole byla aplikována až u pluku přes původní tmavě zelený nátěr horních ploch. SOP byla pravděpodobně modrá, ovšem je možná i jiná barva. Písmena na boku jsou zcela určitě ruské „Za“, pravděpodobně část později dopsaného nápisu jako „Za Rodinu“ nebo „Za Stalina“. Stroj měl novější typ čelní masky krytu motoru, se dvěma na pravou stranu vyosenými oválnými otvory v masce. Pod křídlem nesl čtyři kolejničky pro rakety RS 132 (dvě na každé polovině křídla).

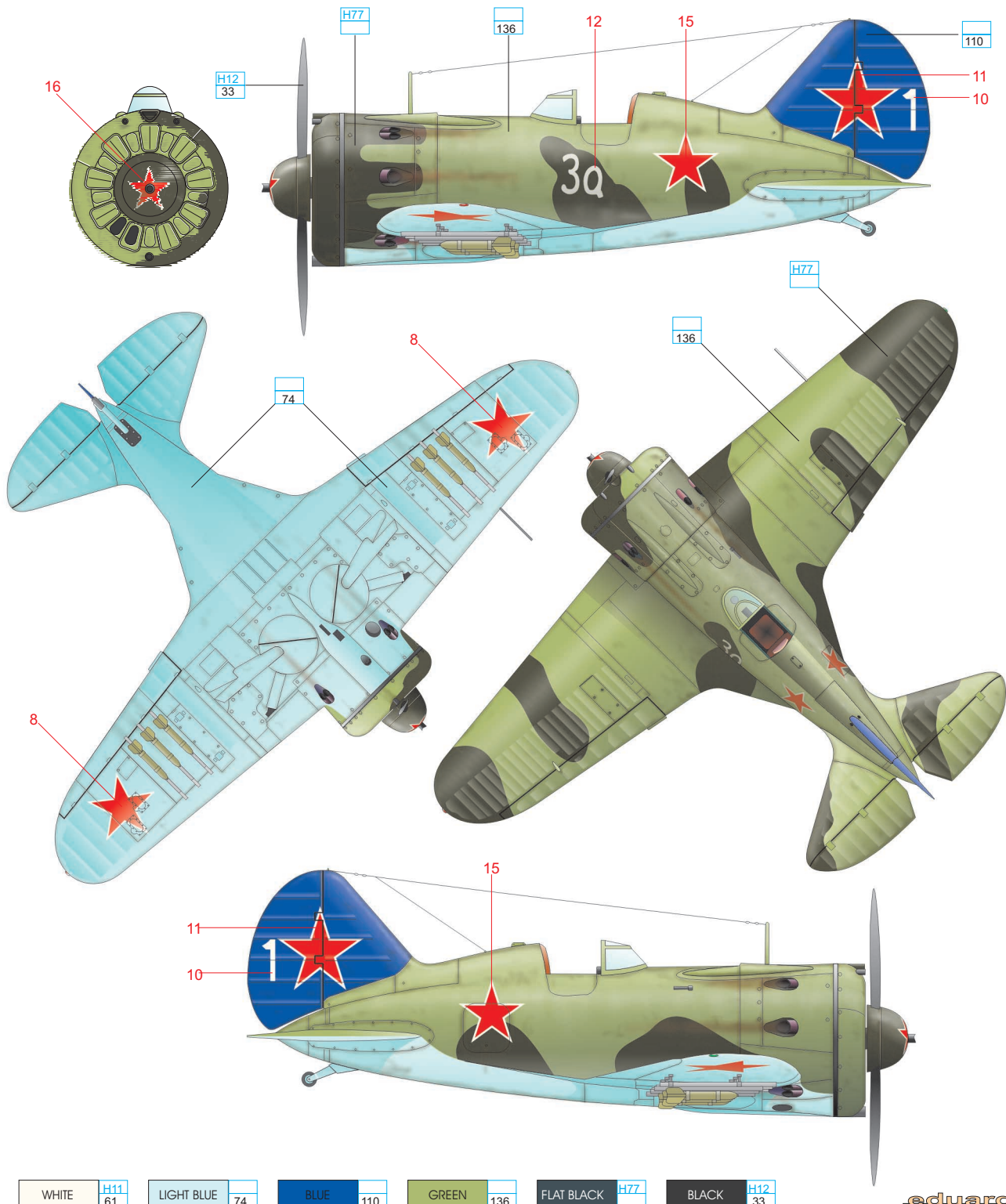

WHITE	H11 61	LIGHT BLUE	74	BLUE	110	GREEN	136	FLAT BLACK	H77	BLACK	H12 33
-------	-----------	------------	----	------	-----	-------	-----	------------	-----	-------	-----------

D 19th Observation escadrille, Rumanian Air Force, 1941

This early I-16 Type 29 (with bottom right-side single squared oil cooler air intake) was captured by advancing Rumanian forces in Moldavia in the summer of 1941, and flown by 19th Observation Escadrille personnel (Capt. Popescu-Ciocanel) for training of observation IAR-39 crews in early July, 1941. Later in August and September, it was employed for trial fights with the IAR-80 fighter. It is not certain if the aircraft wears the original VVS dark green/light blue camouflage, or if it was overpainted. Rumanian national markings are in six positions. Note the yellow Eastern Front identification marks, made up of the fuselage band, wing tips and spinner.

Tento I-16 typ 29 z časné produkce (s jedním hranatým vyoseným vstupem vzduchu k olejovému chladiči) byl ukořistěn Rumunskou armádou v Moldávii v létě 1941. V červenci byl používán 19. pozorovací eskadrou pro nácvik obrany jejich pozorovacích IAR-39 před útoky sovětských I-16. Pilotem I-16 při těchto letech byl kapitán Popescu-Ciocanel. Později, v srpnu a září, byl tento stroj využit k cvičným soubojům se stíhacím IAR-80. Není jisté, zda tato I-16 měla v rumunských rukách původní sovětskou kamufláž, nebo zda byla Rumunsky přestříkána. Určitě měla doplněné identifikační znaky východní fronty, žlutý pruh na trupu, žluté konce křídel a vrtulový kužel.

