

1

Zbarvení & Označení Colours & Markings

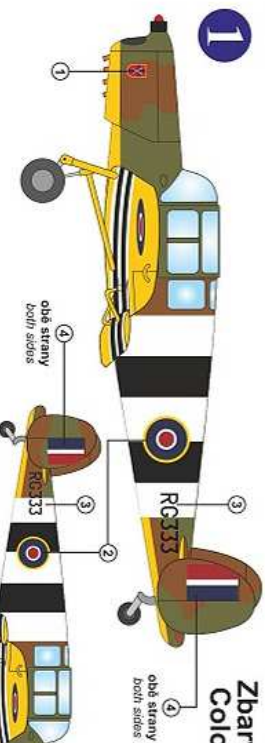
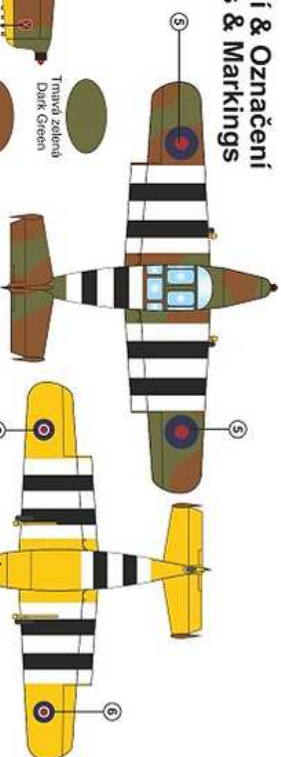
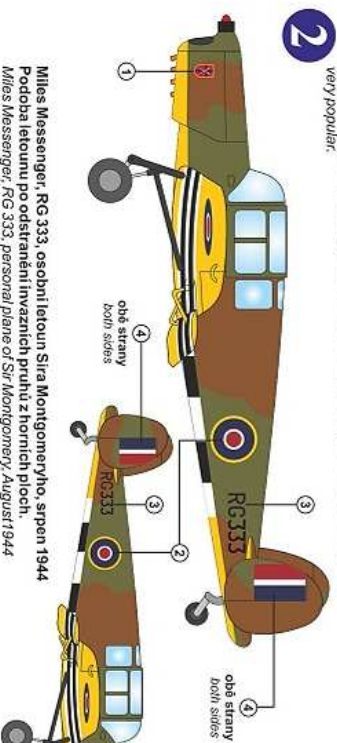

Miles Messenger, RG 333, osobní letoun Sira Montgomeryho, červen 1944
 Ackoliv v RAF sloužilo pouze 20 letounů Messenger, díky RG 333 se stal velmi populárním.
 Miles Messenger, RG 333, personal plane of Sir Montgomery, June 1944
 Although only 20 Messenger aircraft served in the RAF, the RG 333 made them very popular.

2

Miles Messenger, RG 333, osobní letoun Sira Montgomeryho, srpen 1944
 Podoba letounu po odstranění invazních pruhů z horních ploch.
 Miles Messenger, RG 333, personal plane of Sir Montgomery, August 1944
 Aircraft after removal of invasion stripes from upper surfaces.

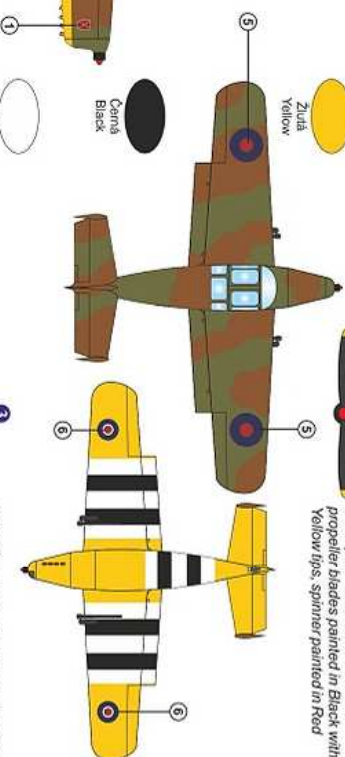
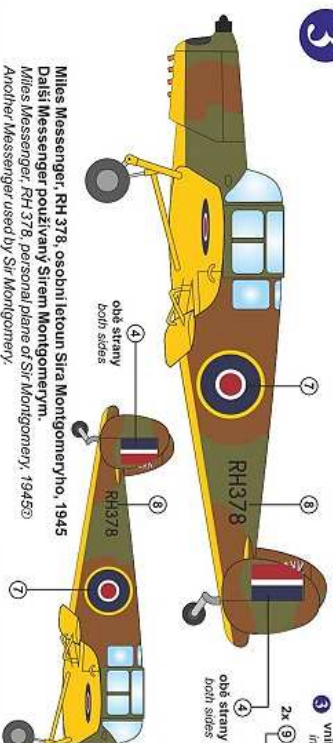
**3**

Miles Messenger, RH 378, osobní letoun Sira Montgomeryho, 1945
 Další Messenger používaný Sirem Montgomerym.
 Miles Messenger, RH 378, personal plane of Sir Montgomery, 1945
 Another Messenger used by Sir Montgomery.

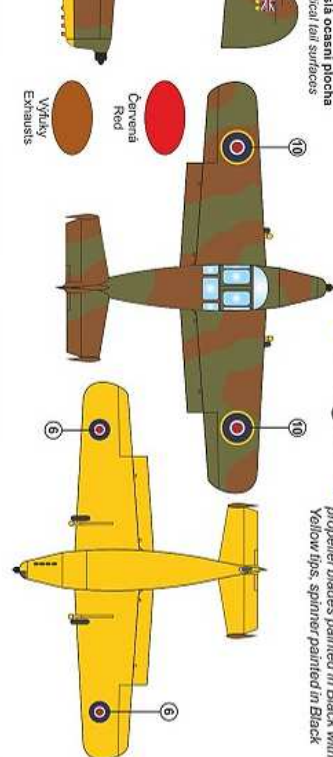

3 vnitřní svítla ocelní plocha
 inner vertical fuel surfaces

3

vrtulové listy černé se žlutými konci, kužel zbarven černě
 propeller blades painted in Black with Yellow tips, spinner painted in Black

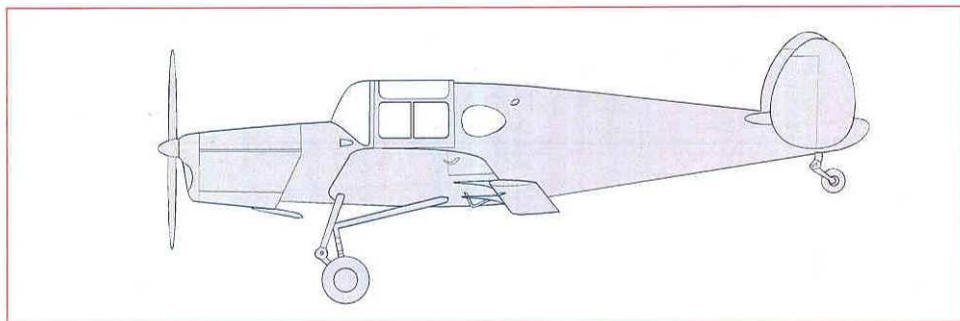

Miles M.38 Messenger Mk I

Historie

Miles M.38 Messenger je britské čtyřmístné spojovací a soukromé letadlo postavené společností Miles Aircraft . Messenger byl navržen tak, aby splňoval požadavky britské armády na robustní leteckou pozorovací stanici a spojovací letoun s nízkou rychlostí a nízkou údržbou. Mezi válečné uživatele tohoto typu patřili maršál Royal Air Force 1. baron Tedder a polní maršál Sir Bernard Montgomery. Během válečných let 21 vyrobených Messengerů přežilo válku sedmáct kusů a po vyřazení z povinností RAF byla většina přeměněna pro civilní použití jako Messenger 4A.

History

The Miles M.38 Messenger is a British four-seat liaison and private owner aircraft built by Miles Aircraft. The Messenger was designed to meet a British Army requirement for a robust, slow speed, low maintenance air observation post and liaison aircraft. Wartime users of the type included Marshal of the Royal Air Force 1st Baron Tedder and Field Marshal Sir Bernard Montgomery . During the war years of the 21 Messengers produced seventeen Messenger 1s survived, and when retired from RAF duties most were converted for civilian use as the Messenger 4A.



VOLITELNÉ
OPTIONAL



VYVRTAT
DRILL HOLE



TMEL
PUTTY



ODSTRANIT
REMOVE

Plastikové díly/Plastic parts

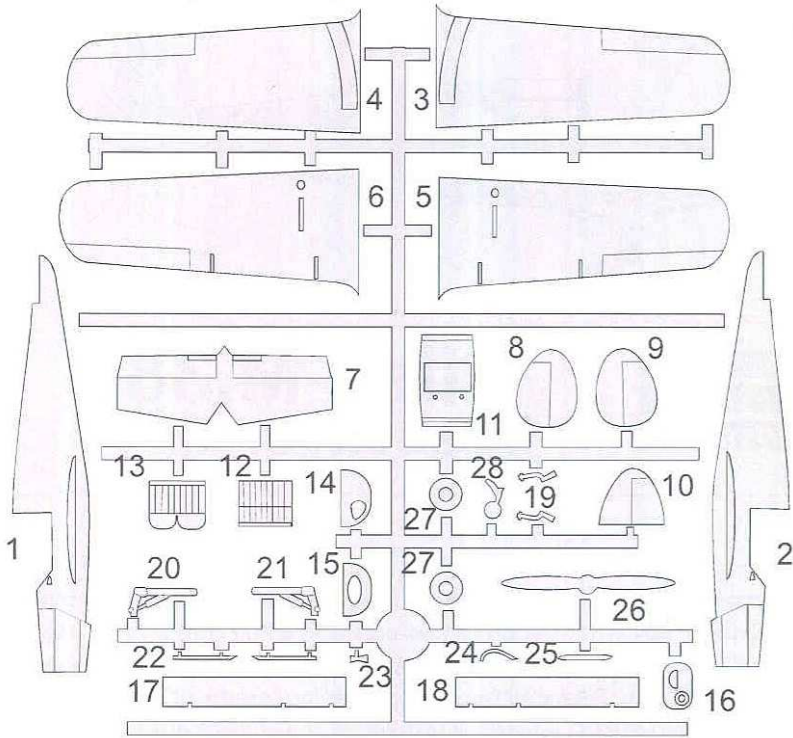

**Průhledné díly/
Clear parts**



C1

Stavební postup - Assembly instructions

1

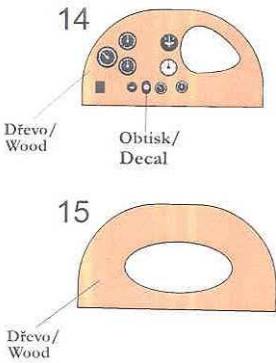

2

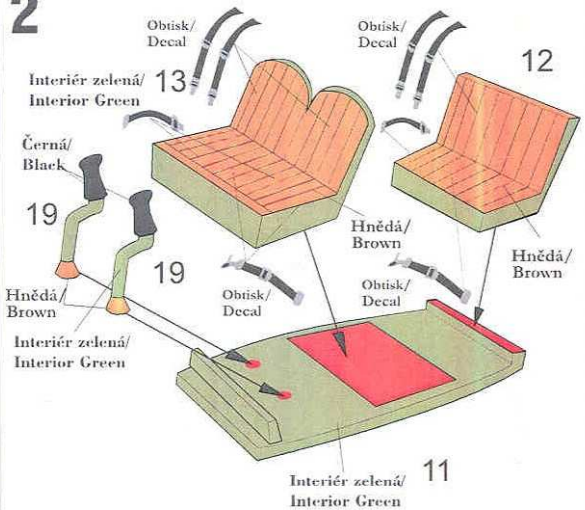

Miles M.38 Messenger Mk I

