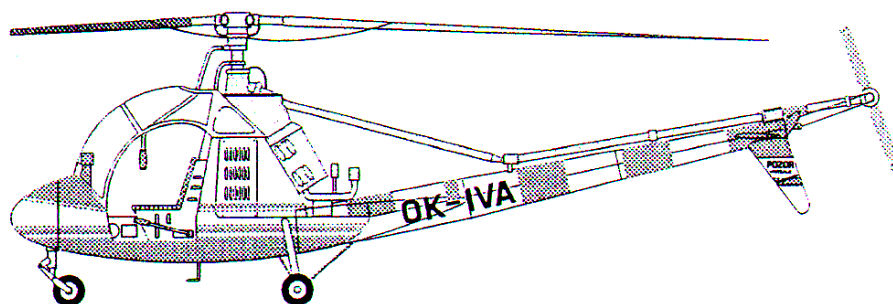
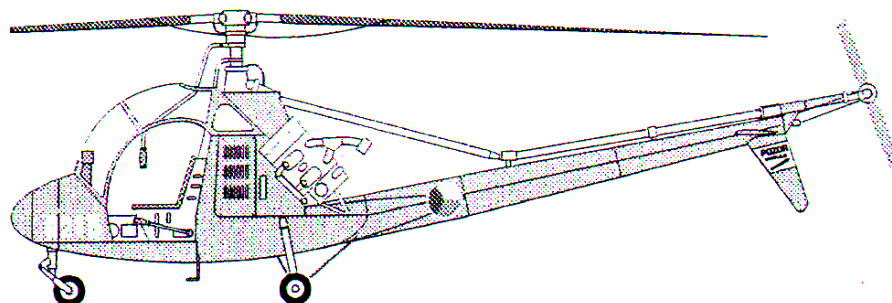


HIGH QUALITY CAST KIT



PMK004

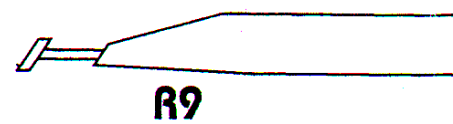
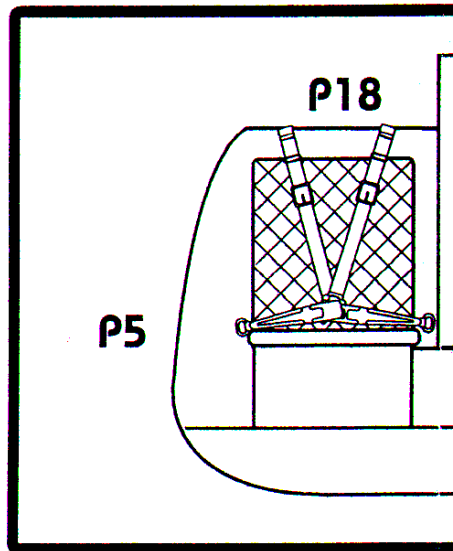
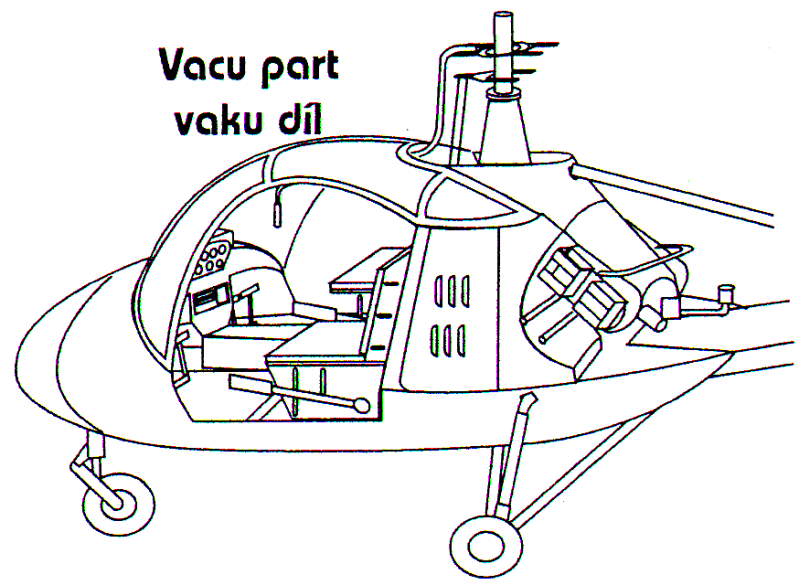
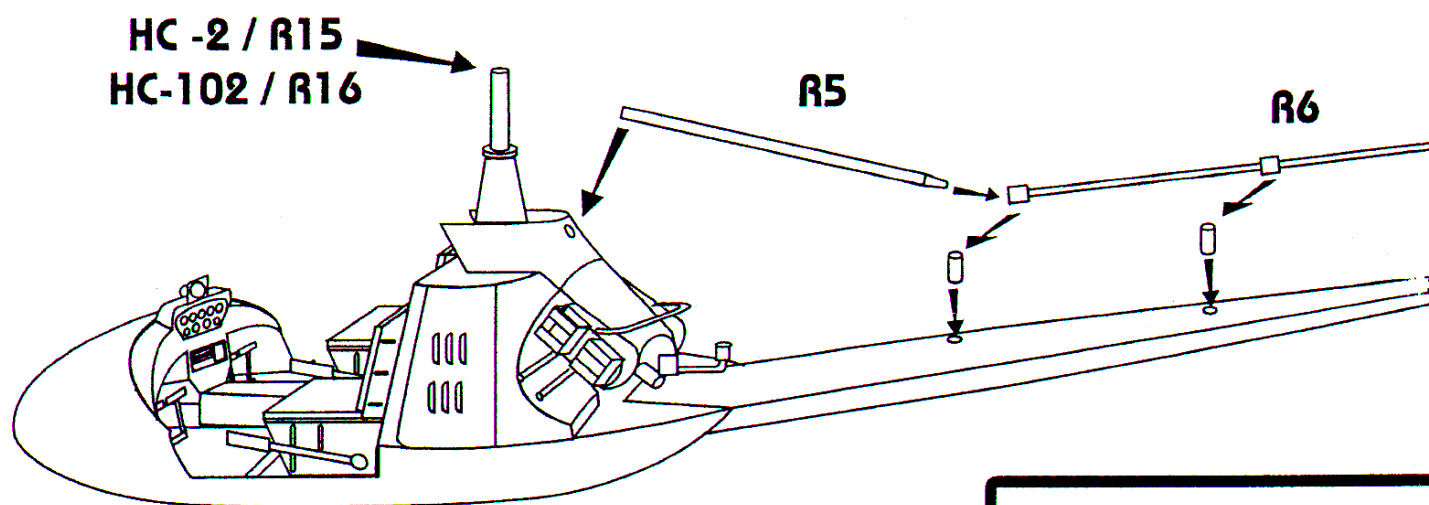
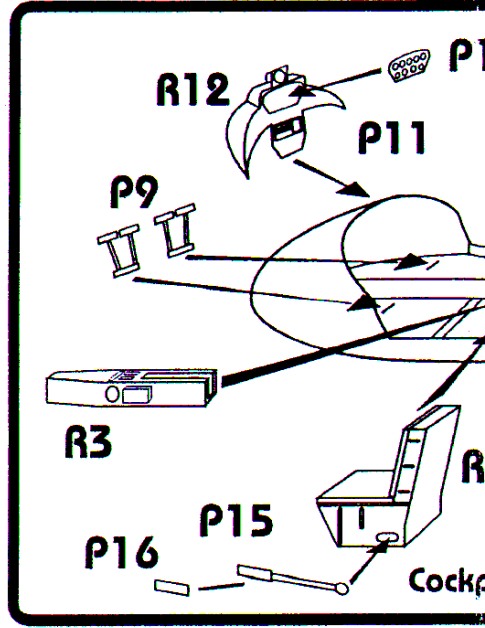
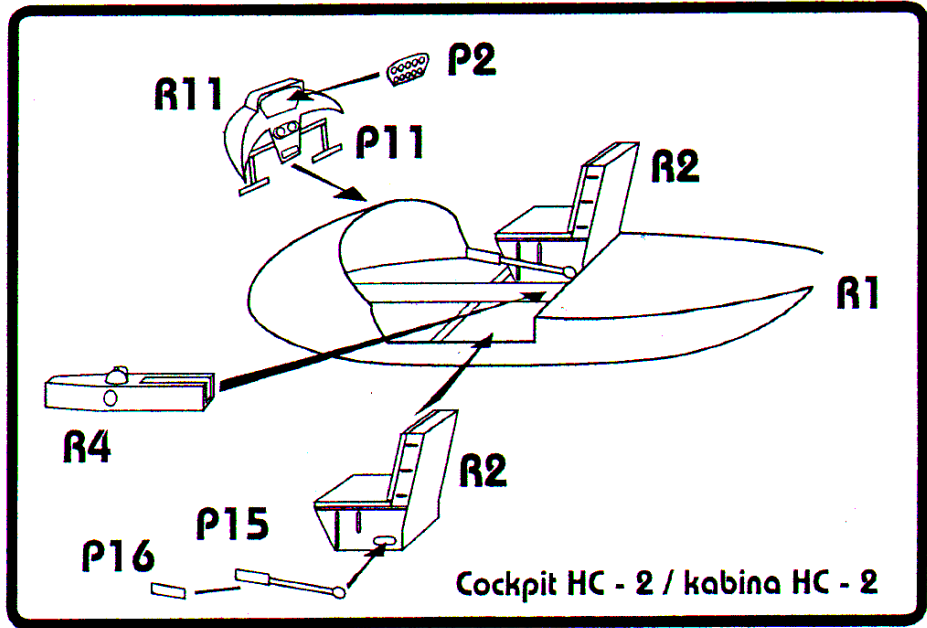
HC - 2 / HC - 102 Československý lehký vrtulník

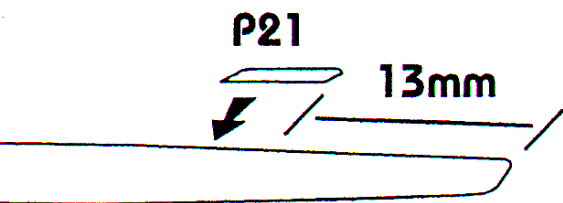
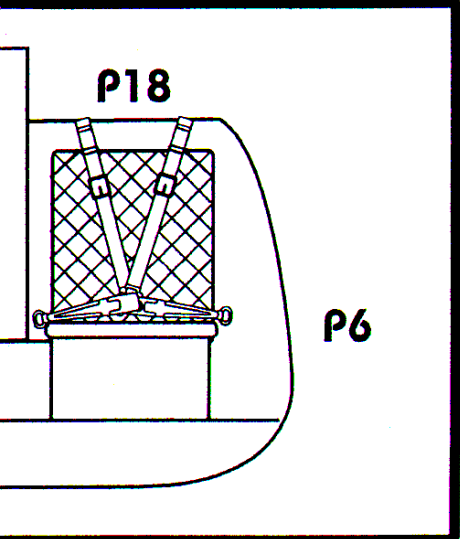
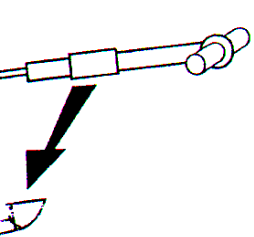
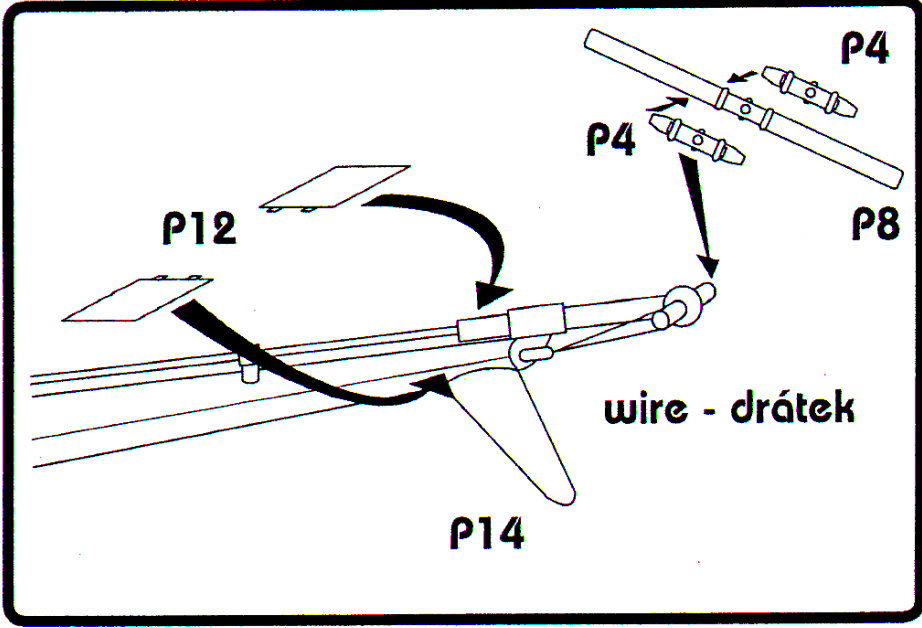
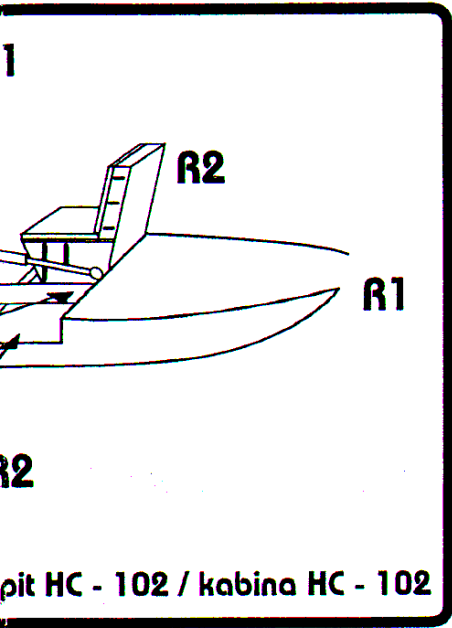
Vrtulníky řady HC - 2 / HC - 102 byly výsledkem práce ing. Šlechty a jeho konstruktérského týmu a představovali jedinou seriově vyráběnou konstrukci čs. vrtulníku. Za přímého předchůdce "hacedvojky" je považován zkušební typ vrtulníku XE - II, který poskytl celou řadu cenných zkušeností na jejichž základě byla v roce 1951 zahájena v prototypové dílně Aerovky stavba prvního prototypu HC - 2. Bohužel z důvodu vytíženosti továrny stavba prototypu šla velmi pomalu kupředu a tak první upoutaný let byl uskutečněn až 3. března 1954 a k prvnímu volnému letu s prototyp vznesl až 3. prosince 1954. Během těchto zkoušek se dokončoval druhý prototyp, který měl zdokonalený překryt kabiny. Vrtulník i přes slabý výkon motoru měl výborné letové vlastnosti a tak v létě 1958 začala seriová výroba v Moravanu Otrokovice která dala 17 seriových strojů. Pod vedením ing. Mikuly pokračoval v Moravanu v další vývoj vrtulníku jehož výsledkem byla zdokonalená verze pod označením HC - 102, která se lišila od původního modelu novým motorem M - 110H a řadou konstrukčních úprav. Výrobce postavil celkem 21 seriových strojů HC - 102. Vojenské letectvo dalo vrtulníku vojenské označení VR - 2 a používalo je ve spojovací službě a pro výcvik a po příchodu sovětských typů je předalo ve větší míře aeroklubům Svazarmu. V současné době je možno oba typy spatřit ve Vojenském leteckém muzeu v Praze / Kbělích.



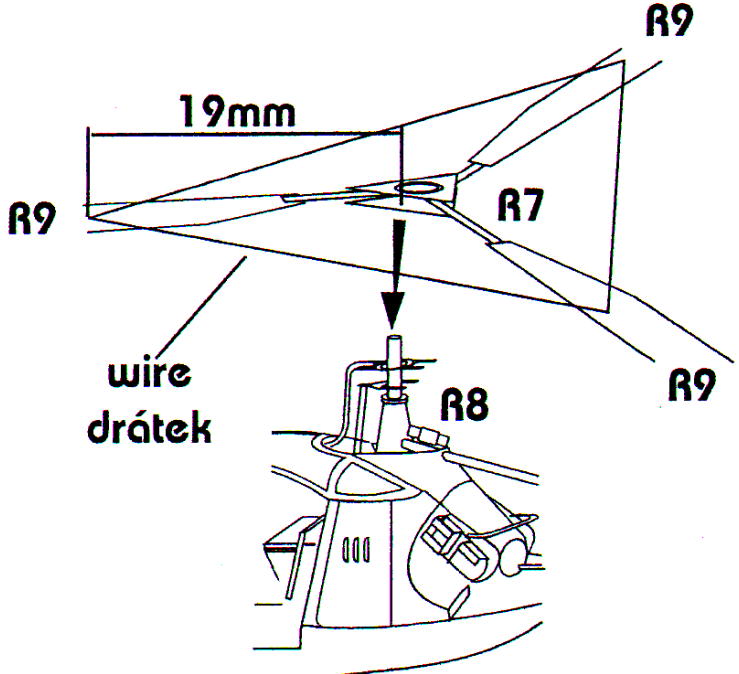
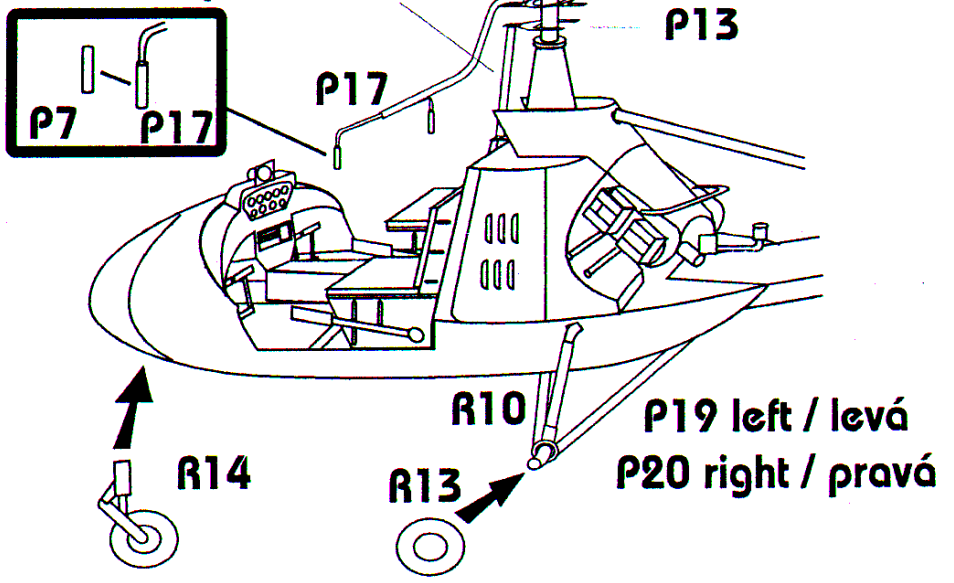
Professional
Model

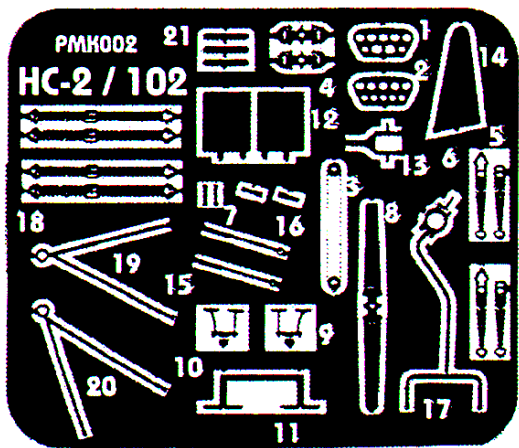
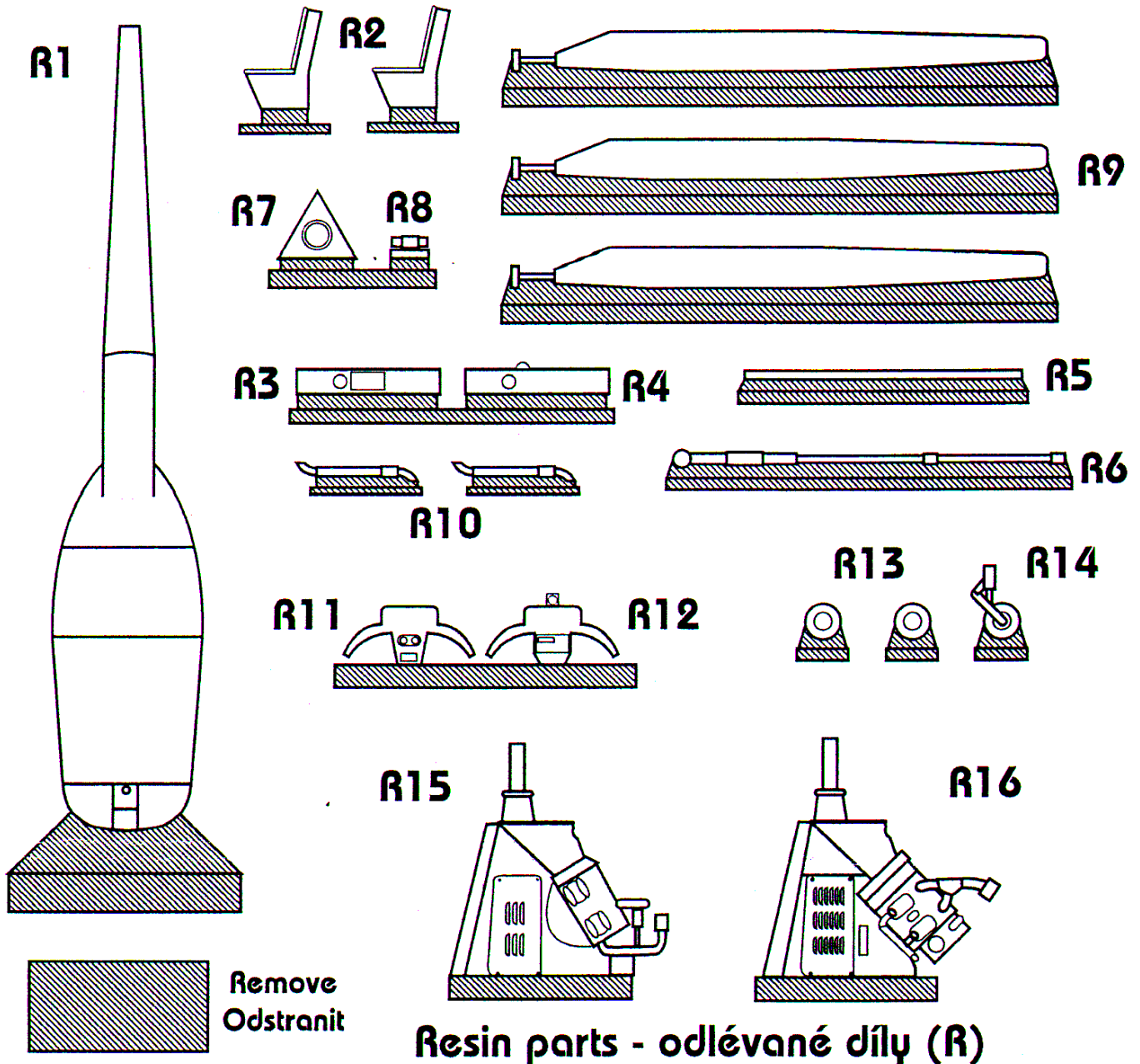
Dygrýnova 822, 198 00 Praha 9
Czech Republic





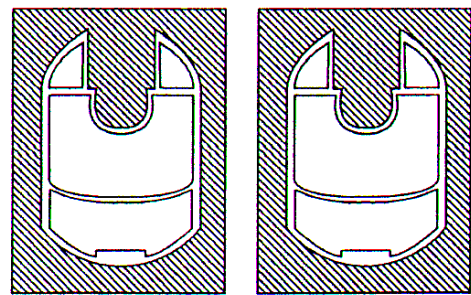
Plastic rod
plastiková tyčka



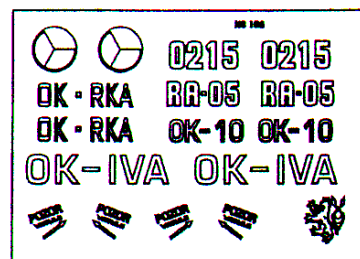


**Photo - etched metal parts
foto - leptané kovové díly
(P)**

Vacu parts - vaku díly (V)

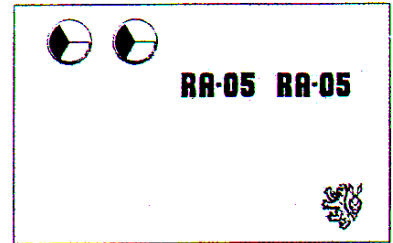


Decals - obtisky (D)



MARKING & COLORS No.1

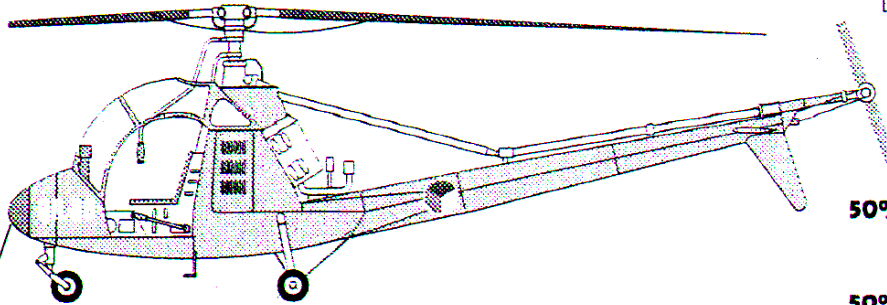
HC - 2 Československé vojenské letectvo
HC - 2 Czechoslovak Air Force



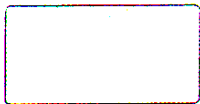
HUMBROL



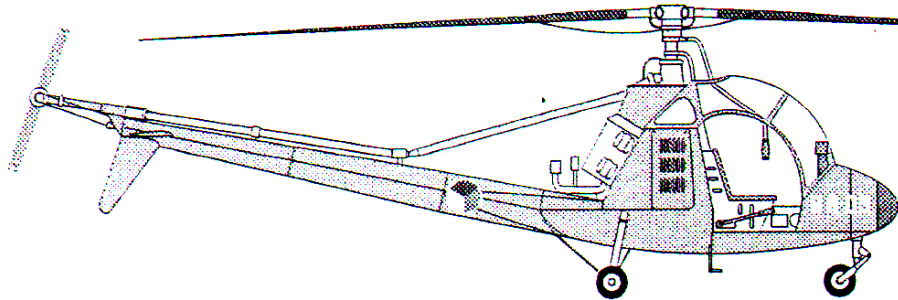
50% **30 Matt Dark Green**
 +
 50% **66 Matt Olive Green**



25 Matt Blue

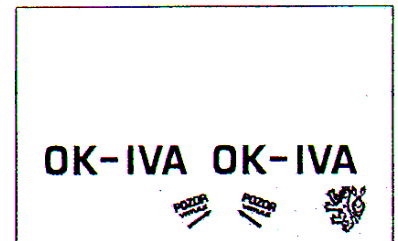


56 Aluminium

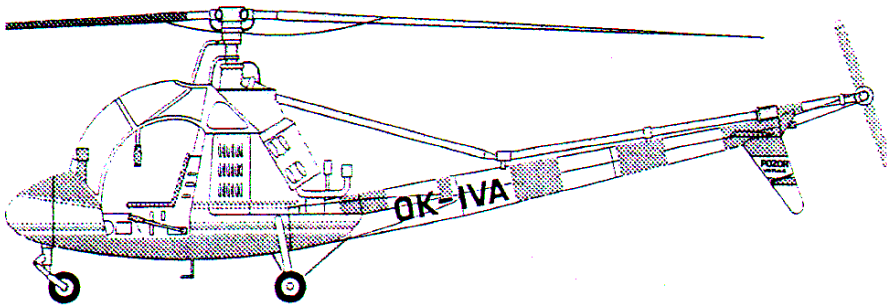


MARKING & COLORS No.2

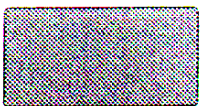
HC - 2 Svazarm
HC - 2 Svazarm



OK-IVA OK-IVA

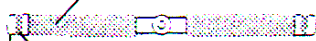


148 Matt Radome Tan



60 Matt Scarlet

62 Matt Leather

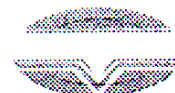
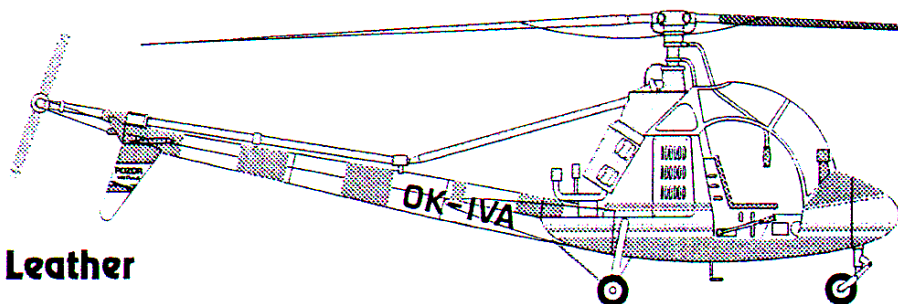


60 Matt Scarlet

154 Insignia Yellow



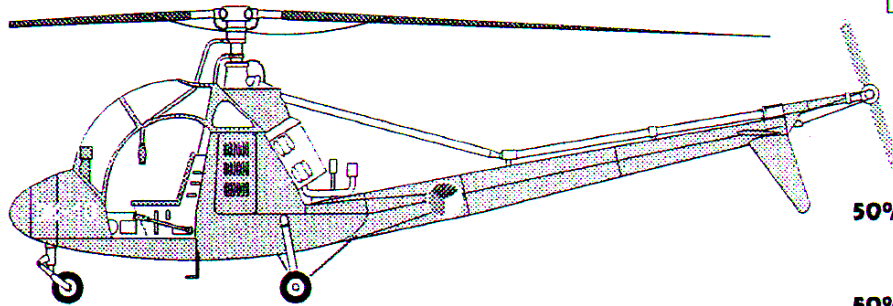
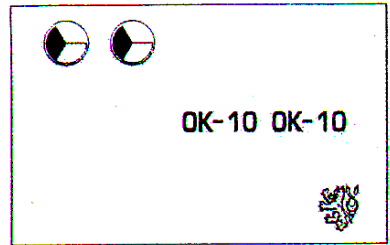
56 Aluminium



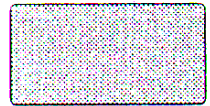
čelní pohled
front view

MARKING & COLORS No.3

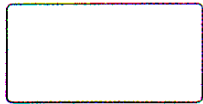
HC - 2 Československé vojenské letectvo
HC - 2 Czechoslovak Air Force



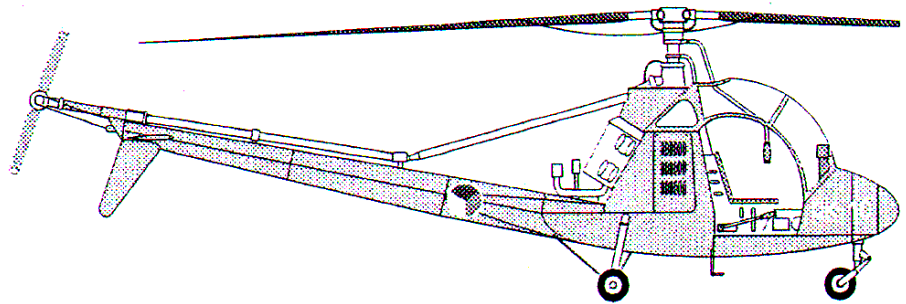
HUMBROL



50% **30** Matt Dark Green
+
50% **66** Matt Olive Green

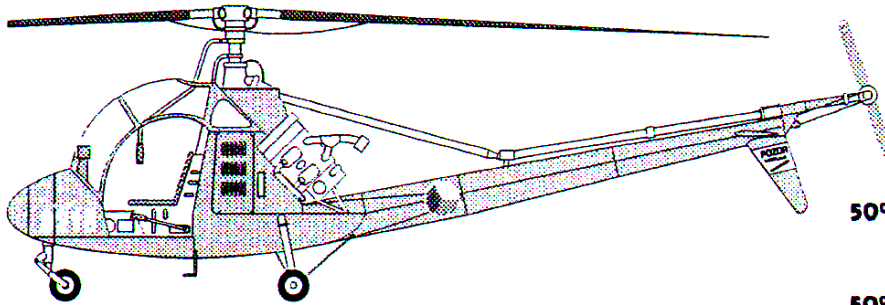
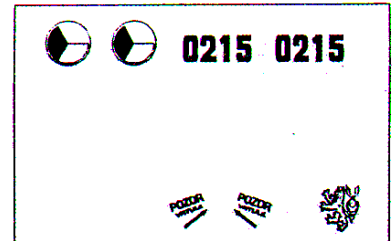


56 Aluminium

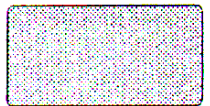


MARKING & COLORS No.4

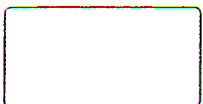
HC - 102 Československé vojenské letectvo
HC - 102 Czechoslovak Air Force



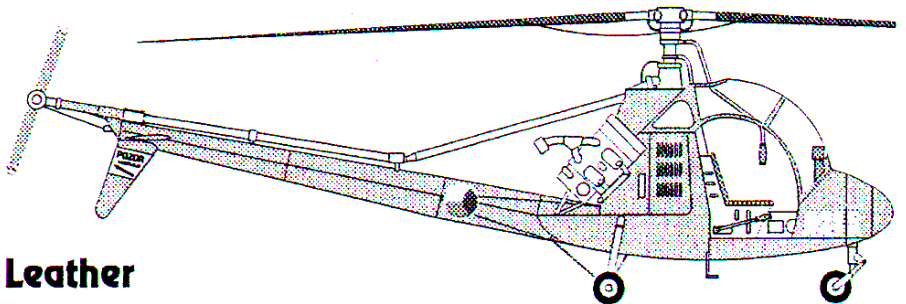
HUMBROL



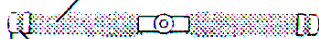
50% **30** Matt Dark Green
+
50% **66** Matt Olive Green



56 Aluminium



62 Matt Leather

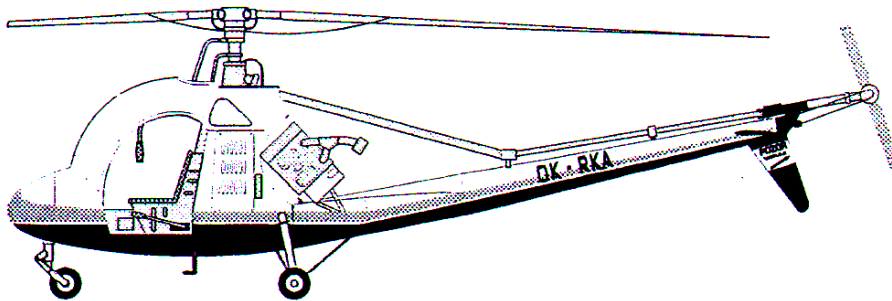
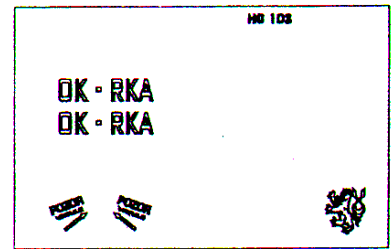


60 Matt Scarlet

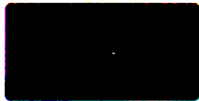
154 Insignia Yellow

MARKING & COLORS No.5

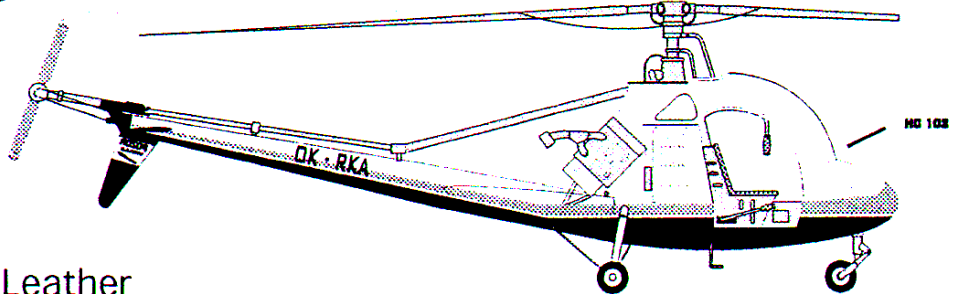
HC - 102 Svazarm
HC - 102 Svazarm



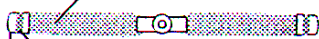
130 Satin White



19 Gloss Red



62 Matt Leather



60 Matt Scarlet

154 Insignia Yellow



14 Gloss Blue