

1/72 SCALE PLASTIC KIT

#BFC094

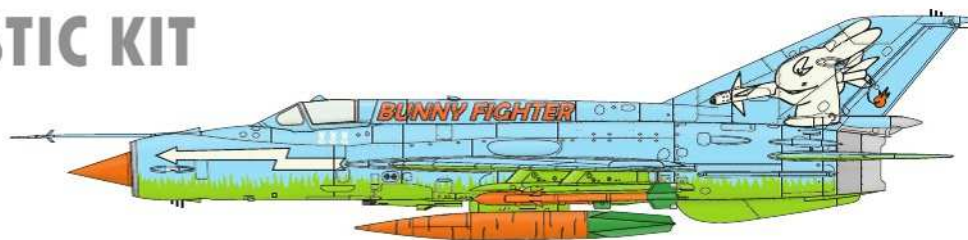

INTRO

The MiG-21 was one of a long list of Mikoyan-Gurevich products to be integrated into the armed forces of the Soviet Union, the Warsaw Pact, and allied client states. Its predecessors included such notable types as the MiG-15, MiG-17 and the supersonic MiG-19. The roots of this project reach back to the first half of the fifties. In 1954, the Ye-1 project came to an end, and was quickly picked up by the Ye-2. Both had a swept wing. The first machine to feature the delta wing was the Ye-4, which first took to the air on June 16th, 1955. It was also demonstrated a year later at the Moscow airfield Tushino. The first of the new line to enter production was the MiG-21F, which together with the MiG-21P and F-13 represented the first generation of the MiG-21, and was in production through the end of the fifties and the beginning of the sixties. Subsequent versions included the PF, FL, PFM, R, etc, the production of which peaked at the end of the sixties. The third generation started production in 1968, which included such versions as M, SM, MF, SMT, BIS among others. Simultaneously, two-seat training versions were also produced designated MiG-21U, UM and US. Production of the MiG-21 ended in 1985, and was put into service with some fifty nations. Over the course of the cold war, the opponents of the MiG-21 included the likes of the Northrop F-5 Freedom Fighter and the Dassault Mirage III. NATO assigned it the reporting name 'Fishbed'. It became the most produced supersonic fighter in terms of quantity. The new machines came off Soviet production lines in Moscow, Gorky and Tbilisi. The MiG-21F-13 was also built under license in Czechoslovakia and the MiG-21FL, M and BIS in India by Hindustan Aeronautics Ltd. The Soviet Union produced 10, 645 examples of all versions, 194 were built in Czechoslovakia and 657 in India. Outside of the Soviet Union, the type flew with a long list of nations on all continents with the exception of Australia. The MiG-21 participated in combat in Vietnam, the Indo-Pakistan wars, the Cuban participation in Angola and in the Arab world's attempt to eliminate Israel. Thanks to the high volume of use, the highest number of aces produced on the type was in Vietnam. The top of the ladder is occupied by Nguyen Van Coc with nine kills. The type serving as a fighter-bomber served with the Soviet Union and other nations of the Warsaw Pact into the eighties, when it began to be displaced by the MiG-29 Fulcrum.

This kit allows you to build foremost a model of the MiG-21MF. This is an export version of the SM where the 'M' signifies 'modernizovaniy' and the 'F' 'forsirovaniy' – or 'modernized with afterburning'. In factory documentation, the type is identified as Izdelye 96F. It was powered by the Tumansky R-13-300 with afterburning and carried the Sapfir-21/RP-22 radar. The armament was composed of the GS-23-2L 23mm cannon with 200 rounds. The underwing pylons could carry a combination of FAB bombs up to 500kg in size, UB-16-57 rocket pods, and R-3S, Ch-66, S-24 missiles, as well as R-60 air-to-air missile, including the R-60M. NATO assigned the MiG-21MF the codename 'Fishbed J'.

ÚVODEM

MiG-21 byl další konstrukcí kanceláře Mikojan-Gurjevič, která se zařadila do výzbroje Sovětského svazu, zemí Varšavské smlouvy a dalších ozbrojených sil. Jeho předchůdci byly tak významné typy jako MiG-15, MiG-17 či nadzvukový MiG-19. Kořeny vývoje letounu sahají do první poloviny 50. let minulého století. V roce 1954 byl dokončen projekt Je-1, velmi rychle nahrazený druhým prototypem Je-2. Oba měly šípové křídlo. Prvním strojem s delta křídlem byl prototyp Je-4, který se do vzduchu dostal poprvé 16. června 1955. Představil se také na letecké přehlídce, která se konala o rok později na moskevském letišti Tušino. Jako první se do sériové výroby dostala verze MiG-21F, která společně s MiG-21P a MiG-21F-13 reprezentovala první generaci tohoto typu, vyráběnou na přelomu 50. a 60. let minulého století. Následovaly další, pokročilejší verze – PF, FL, PFM, R atd., jejichž produkce vyvrcholila v druhé polovině 60. let. Od roku 1968 probíhala výroba třetí generace, která zahrnovala například verze M, SM, MF, SMT, BIS a další. Souběžně se stavěly také dvoumístné cvičné jednadvacítky MiG-21U, UM a US. Výroba MiGů-21 skončila v roce 1985 a do výzbroje je zařadilo okolo 50 zemí světa. MiG-21 měl během studené války své protějšky v typech Northrop F-5 Freedom Fighter či Dassault Mirage III. Vojska NATO dalo typu kódové označení Fishbed. Stal se v největších počtech vyráběným nadzvukovým letounem. Nové stroje v Sovětském svazu sjížděly z továrních linek v Moskvě, Gorkém a Tbilisi. V licenci se stavěla verze MiG-21F-13 v Československu a MiG-21FL, M a BIS v Indii u Hindustan Aeronautics Ltd. V Sovětském svazu vzniklo 10 645 exemplářů všech verzí, v Československu 194 kusů a v Indii 657 strojů. Kromě ozbrojených sil Sovětského svazu létal s řadě zemí, s výjimkou Austrálie na všech kontinentech. Zúčastnil se řady válečných konfliktů, včetně války ve Vietnamu, indicko-pákistánských potyček, kubánského tažení v Angole či arabské snahy o zničení Izraele. Díky největšímu zapojení do bojových akcí se největší počet stíhacích es zrodil ve Vietnamu. Na čele žebříčku stojí Nguyen Van Coc s devíti sestřely. V roli přepadového stíhacího letounu sloužily MiGy-21 v Sovětském svazu a dalších zemích Varšavské smlouvy až do 80. let, kdy jej jako plnohodnotná náhrada začaly z prvoliniové služby vytlačovat nové MiGy-29 Fulcrum.

Z této stavebnice si můžete postavit zejména modely letounů MiG-21MF. Jde o exportní variantu verze SM, kde písmeno „M“ znamená „modernizovaný“ a písmeno „F“ pak „forsirovaný“ – tedy modernizovaný s přídavným spalováním. V tovární dokumentaci figuruje pod označením Izdělje 96F. Poháněl ji motor Tumanskij R-13-300 s přídavným spalováním a nesl radar Safir-21/RP-22. Výzbroj tvořil kanon GŠ-23-2L ráže 23 mm se zásobou 200 ran. Na závěsníky bylo možné podvěsit kombinaci pum FAB až do ráže 500 kg, raketnic UB-16-57U a raket R-3S, Ch-66, S-24, včetně rakety vzduch-vzduch R-60 a její infračerveně naváděné varianty R-60M. V kódu NATO nesly MiGy-21MF označení Fishbed J.

ATTENTION



UPOZORNĚNÍ



ACHTUNG



ATTENTION



注意



Carefully read instruction sheet before assembling. When you use glue or paint, do not use near open flame and use in well ventilated room. Keep out of reach of small children. Children must not be allowed to suck any part, or pull vinyl bag over the head.



Před započatím stavby si pečlivě prostudujte stavební návod. Při používání barev a lepidel pracujte v dobře větrané místnosti. Lepidla ani barvy nepoužívejte v blízkosti otevřeného ohně. Model není určen malým dětem, mohlo by dojít k požití drobných dílů.

INSTRUCTION SIGNS

* INSTR. SYMBOLS

* INSTRUKTION SINNBILDEN

* SYMBOLES

* 記号の説明

OPTIONAL
VOLBABEND
OHNOUTSAND
BROUSITOPEN HOLE
VYVRTAT OTVORSYMETRICAL ASSEMBLY
SYMETRICKÁ MONTÁŽREMOVE
ODRÍZNOUTREVERSE SIDE
OTOČITAPPLY EDUARD MASK
AND PAINT
POUŽIT EDUARD MASK
NABARVIT

PARTS



DÍLY



TEILE



PIÈCES



部品

PLASTIC PARTS

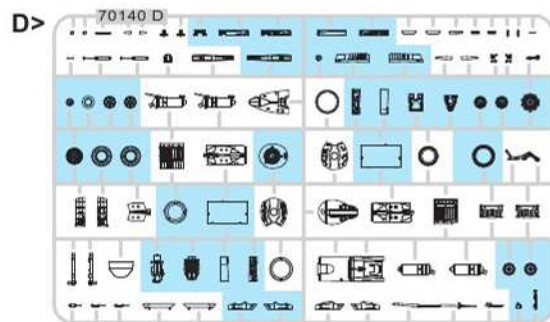
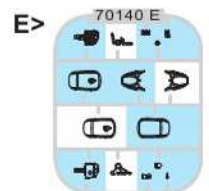
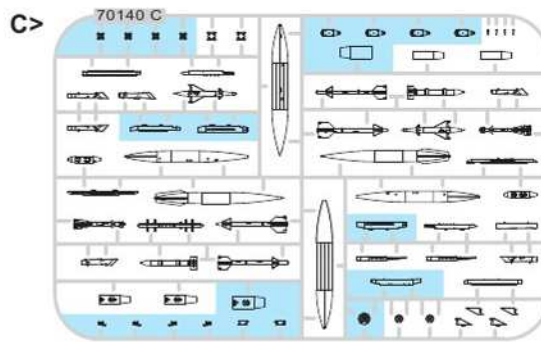
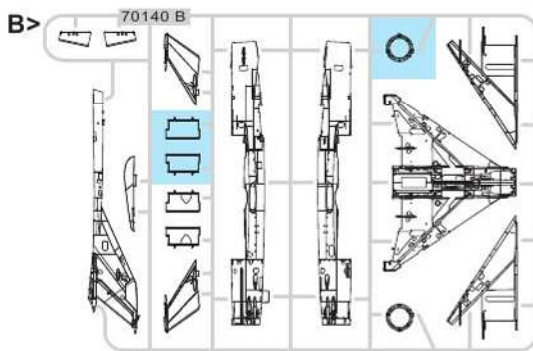
RP - RESIN PARTS
Eduard
BRASSIN

PE - PHOTO ETCHED DETAIL PARTS

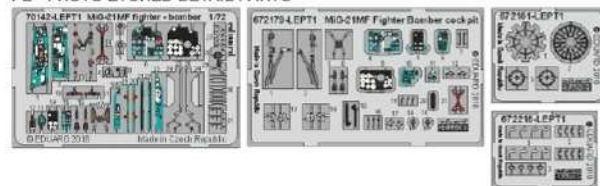

-Parts not for use. -Teile werden nicht verwendet. -Pièces à ne pas utiliser. -Tyto díly nepoužívejte při stavbě. - 使用しない部品

COLOURS



BARVY



FARBEN



PEINTURE



色

GSI Creos (GUNZE)		MISSION MODELS	
AQUEOUS	Mr.COLOR	PAINTS	
H1	C1	MMP-001	WHITE
H3	C3	MMP-003	RED
H4	C4	MMP-007	YELLOW
H5	C5	MMP-048	BLUE
H6	C6	MMP-004	GREEN
H7	C7	MMP-002	BROWN
H11	C62	MMP-001	FLAT WHITE
H12	C33	MMP-047	FLAT BLACK
H14	C59	MMP-005	ORANGE
H15	C65		BRIGHT BLUE
H26	C66		BRIGHT GREEN
H47	C41	MMP-012	RED BROWN
H51	C11	MMP-063	LIGHT GULL GRAY
H53	C13		NEUTRAL GRAY
H87	C115	MMP-057	LIGHT BLUE
H70	C60	MMP-056	GRAY
H71	C21	MMP-078	MIDDLE STONE

GSI Creos (GUNZE)		MISSION MODELS	
AQUEOUS	Mr.COLOR	PAINTS	
H77	C137	MMP-040	TIRE BLACK
H81	C55	MMP-023	KHAKI
H82	C32		DARK GRAY
H84	C42		MAHOGANY
H90	C47		CLEAR RED
H94	C138		CLEAR GREEN
H302	C302		GREEN
H323	C323		LIGHT BLUE
H332	C332		LIGHT AIRCRAFT GRAY
H338	C338	MMP-116	LIGHT GRAY
	C391		INTERIOR GREEN
Mr.METAL COLOR		METALLICS	
MC213		MMM-006	STEEL
MC214		MMM-001	DARK IRON
MC218		MMM-003	ALUMINIUM
Mr.COLOR SUPER METALLIC		METALLICS	
SM201		MMC-001	SUPER FINE SILVER 2

1 =

0170 MMP	C68	056	- MARKINGS A : B : C
0181 MMP	C68	056	- MARKING D

 LIGHT GULL GRAY

A

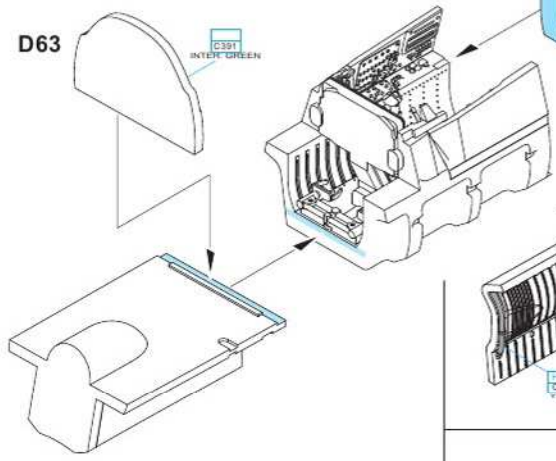
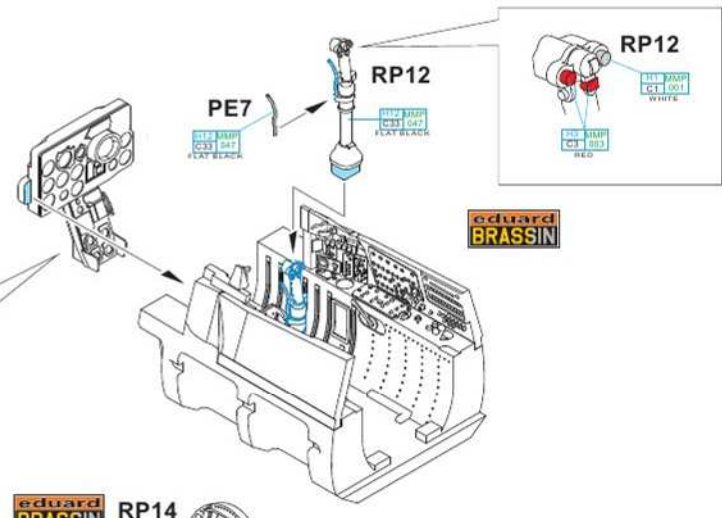
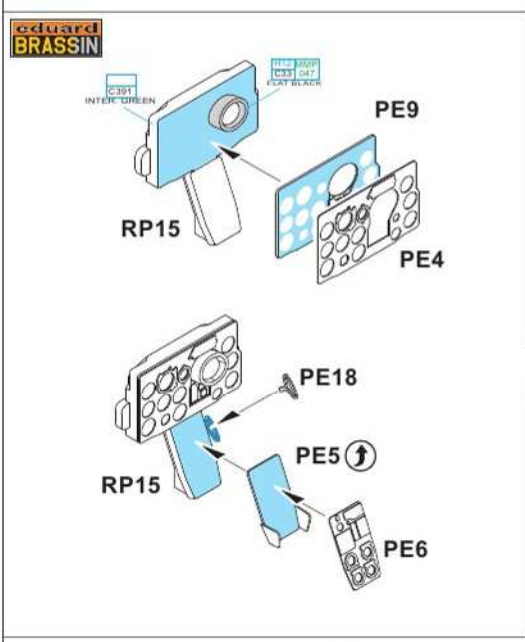
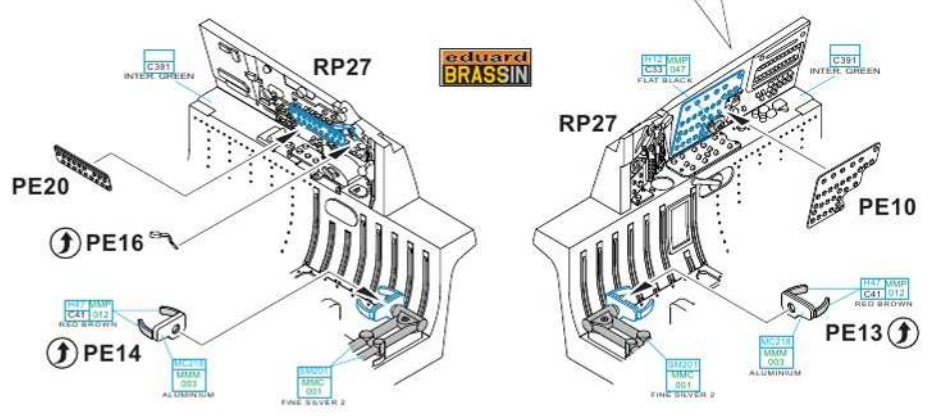
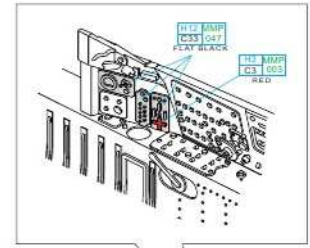
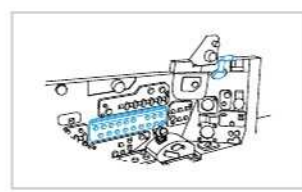
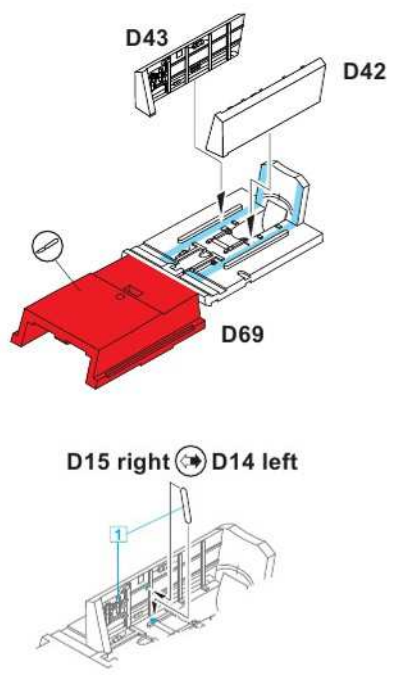

B

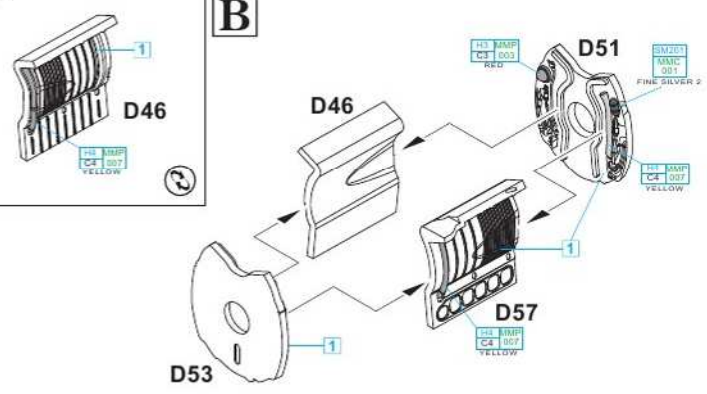

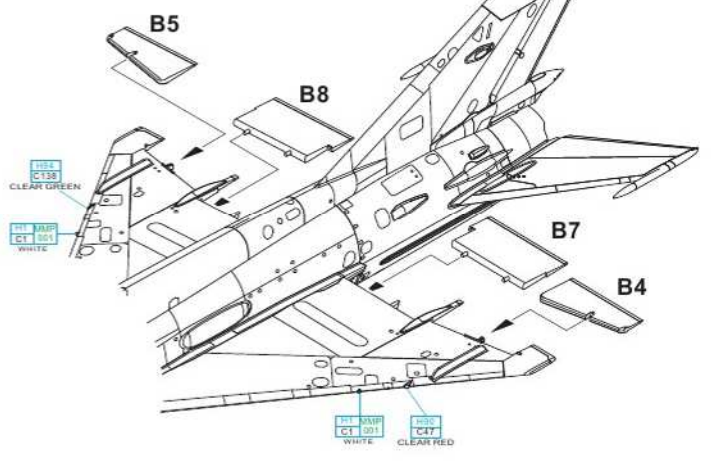
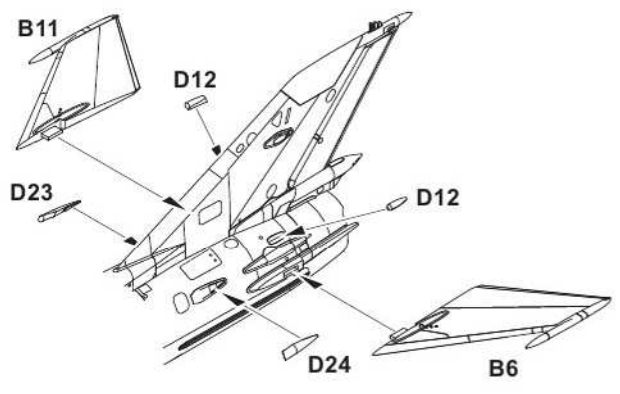
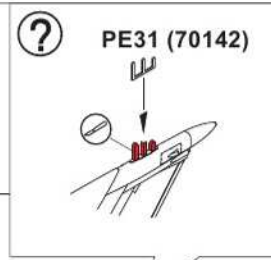
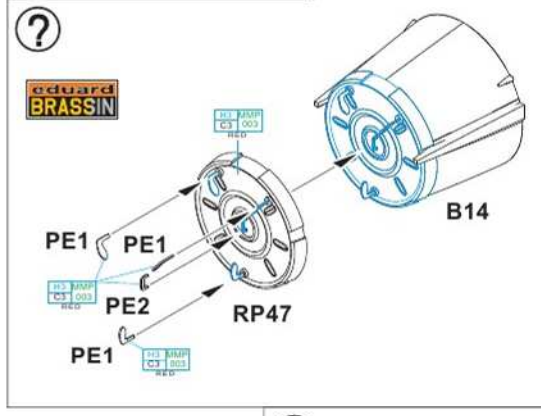
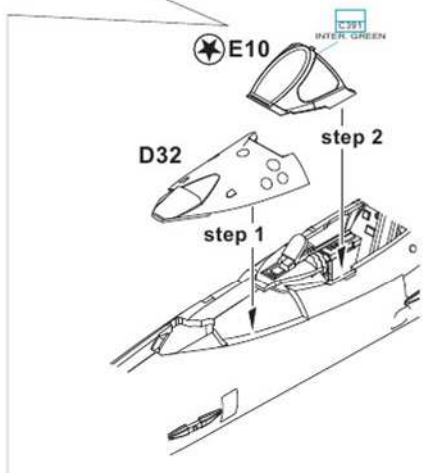
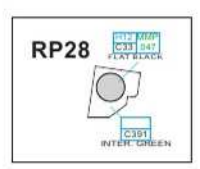
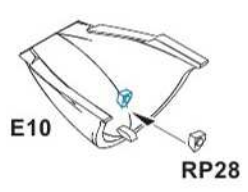
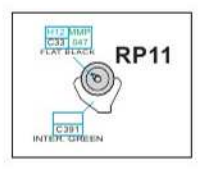
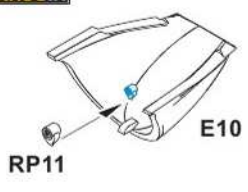
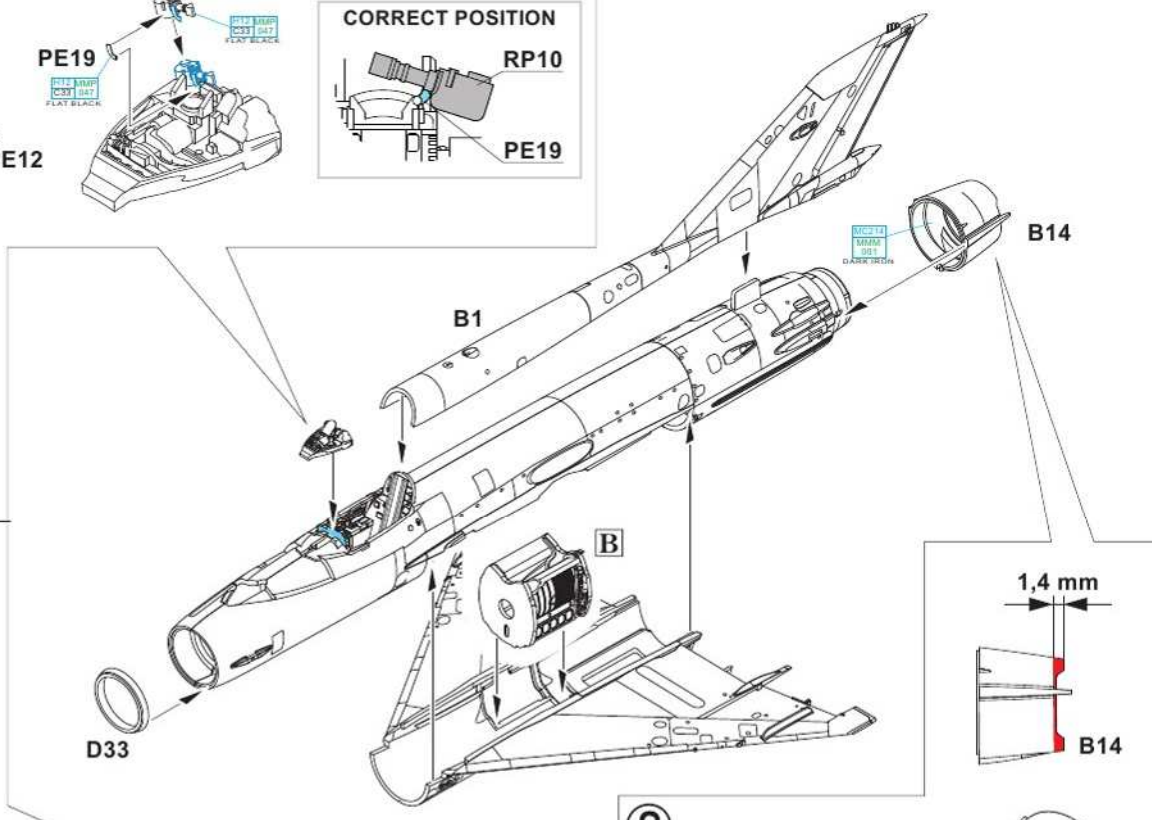
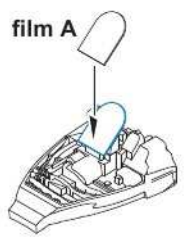
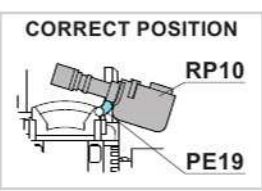
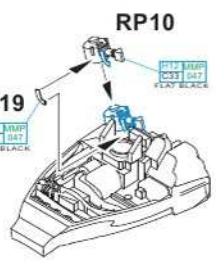
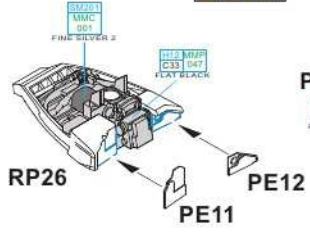

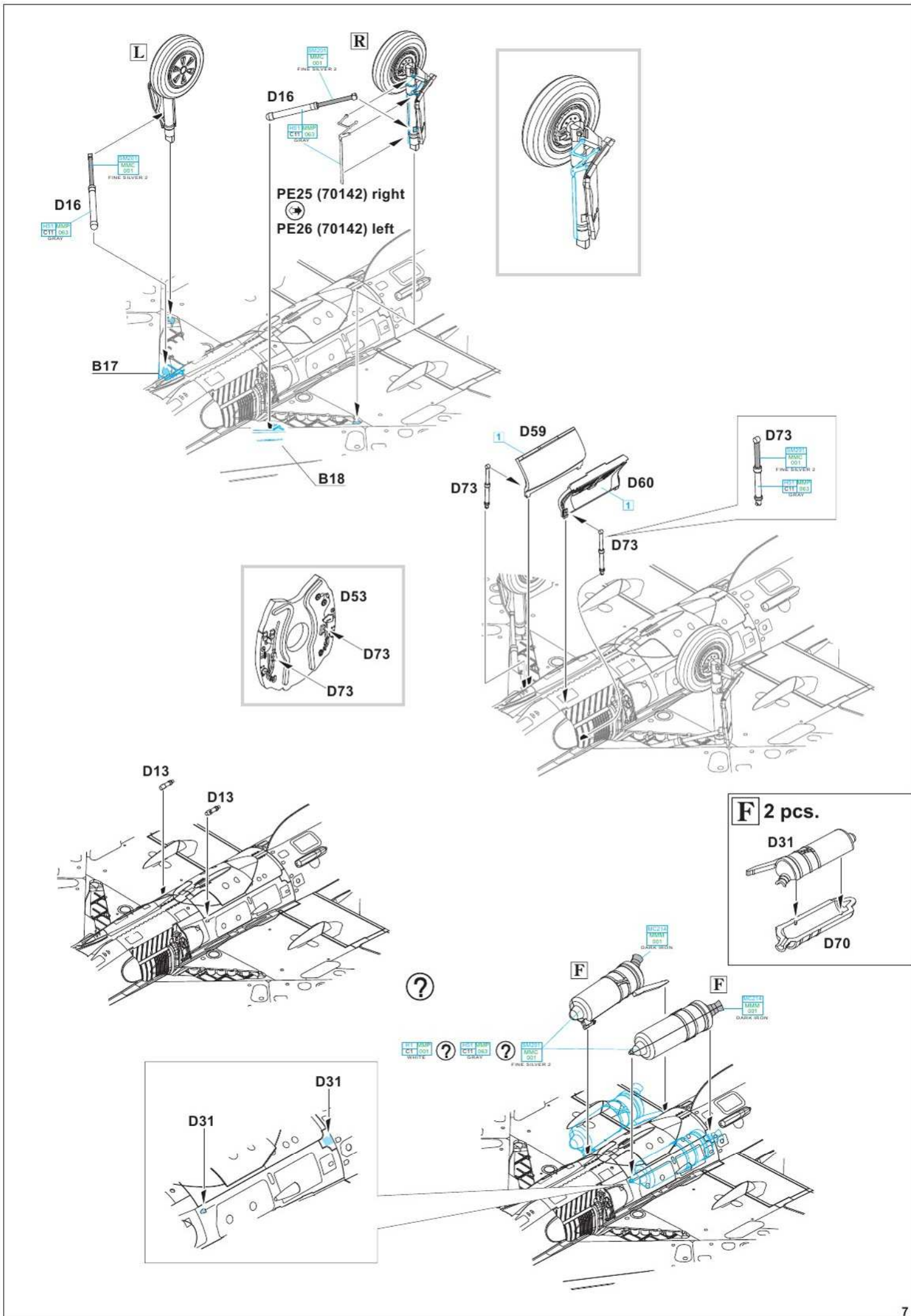

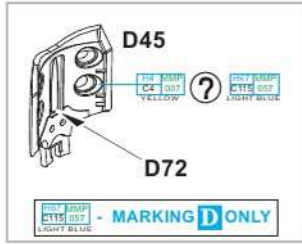

OPEN air brake
D45

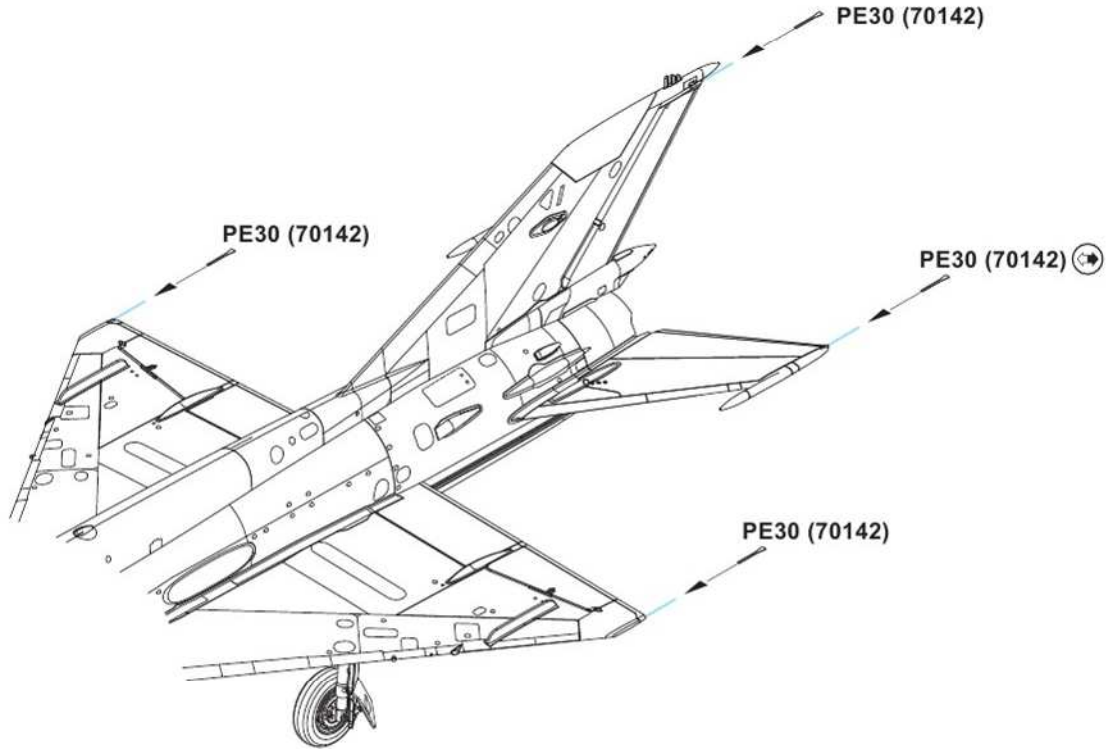
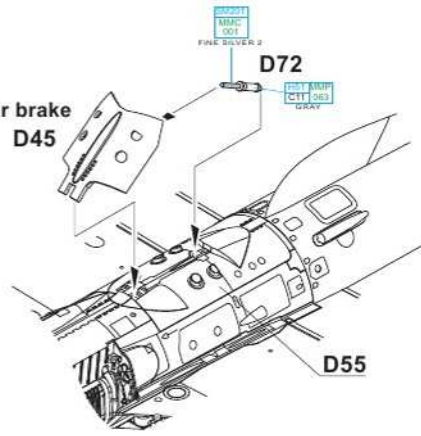

G

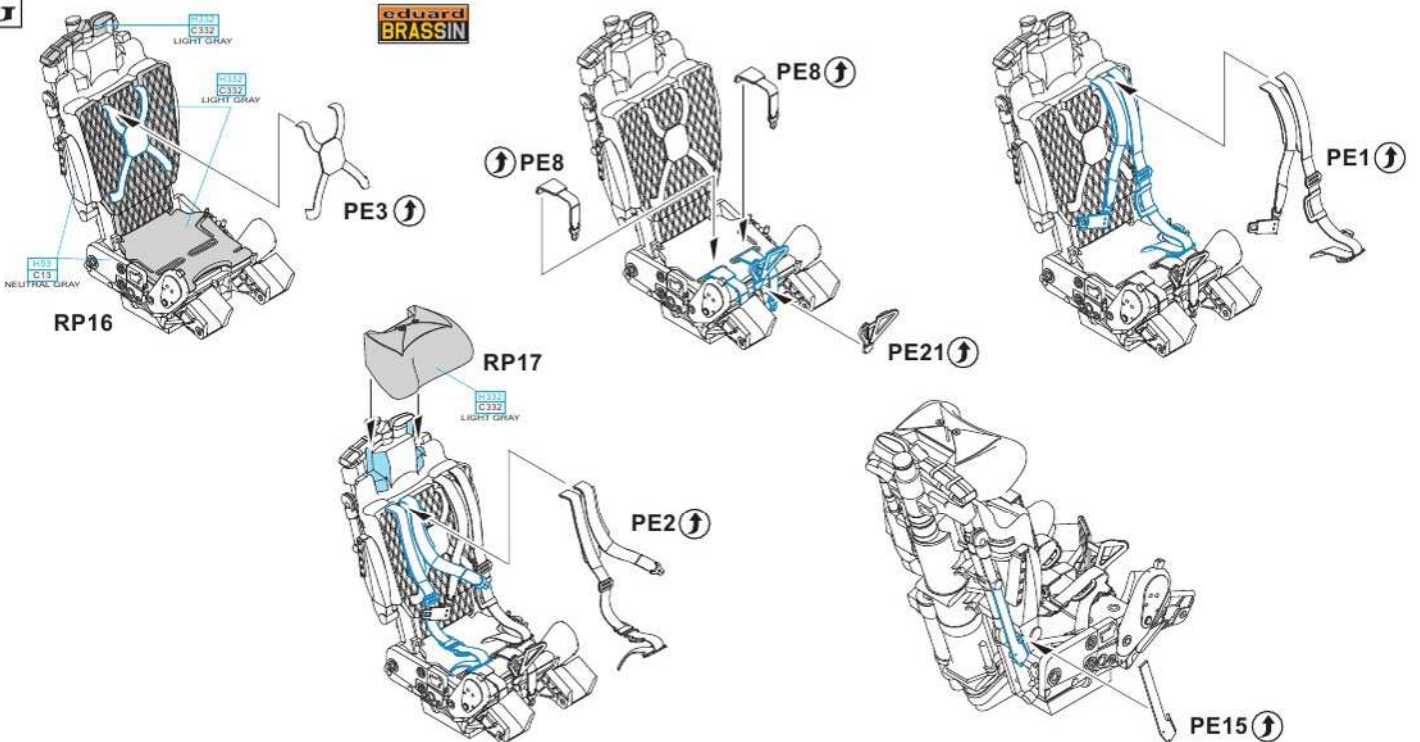

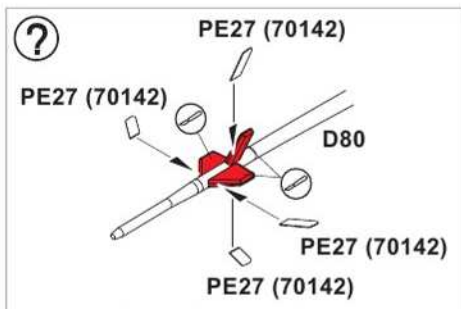
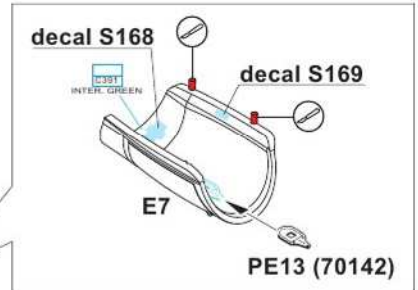
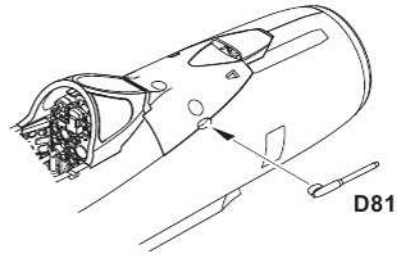
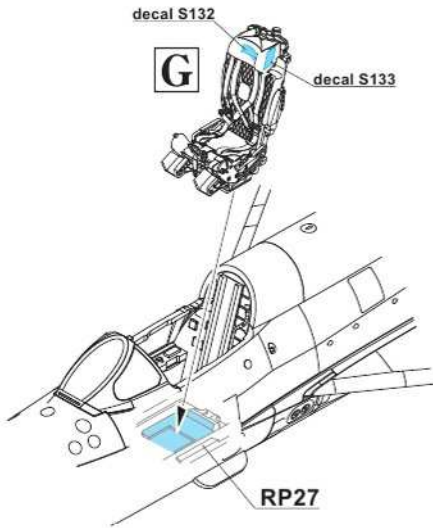

CLOSED CANOPY
 ⚙ E7

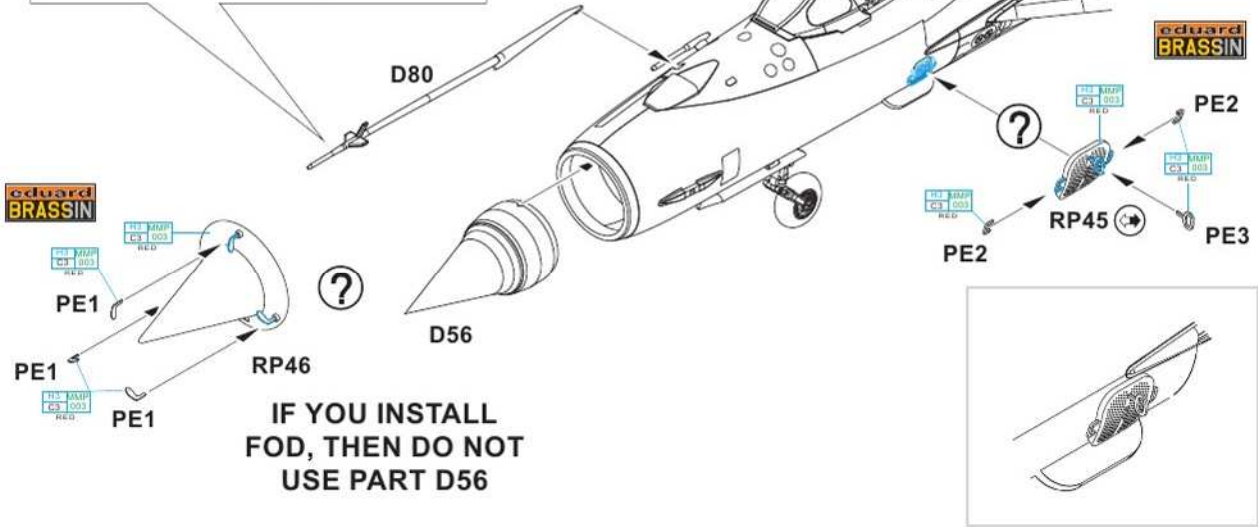

IF YOU INSTALL
 FOD, THEN DO NOT
 USE PART D56



OPEN CANOPY
 ⚙ E7

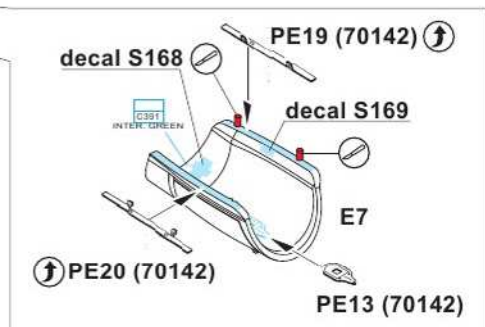
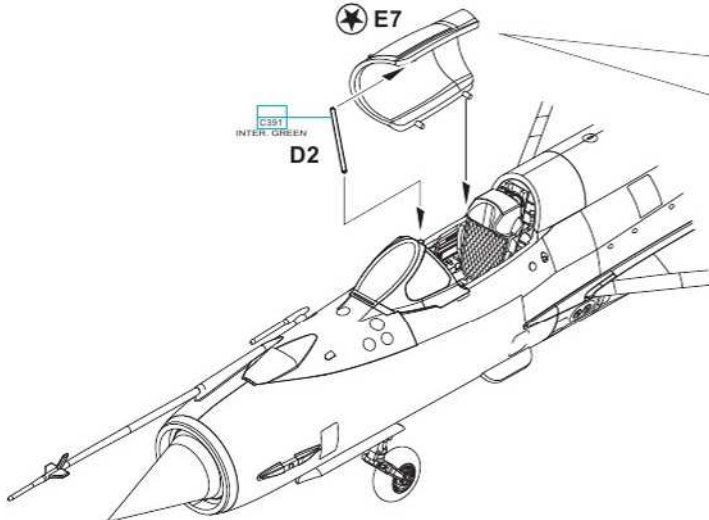

EXTERNAL FUEL TANK 800 l
PŘÍDAVNÁ NÁDRŽ 800 l

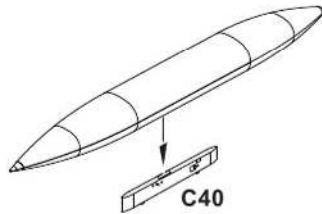
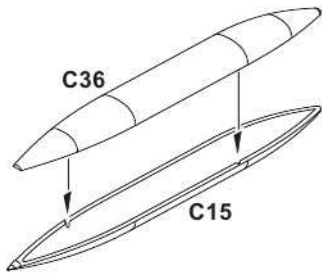

EXTERNAL FUEL TANK 490 l
PŘÍDAVNÁ NÁDRŽ 490 l
2 pcs.

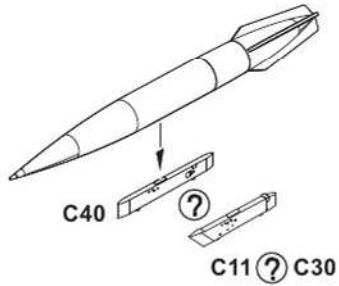
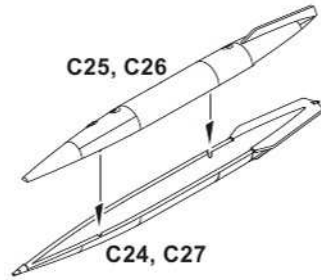

RS-2US
2 pcs.

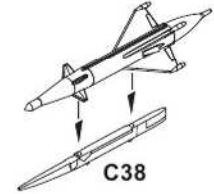
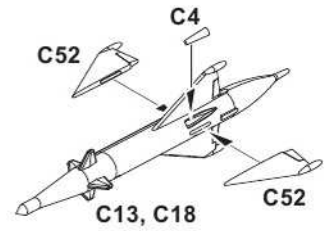

R-13
2 pcs.

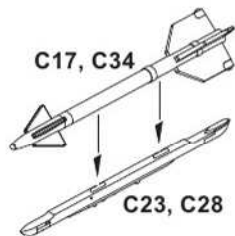

R-3S
2 pcs.

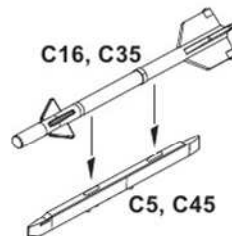

S24
2 pcs.

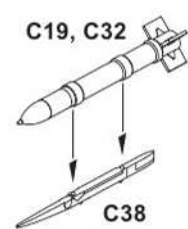

BOMB 250
2 pcs.

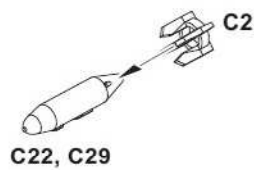

UB-16
2 pcs.

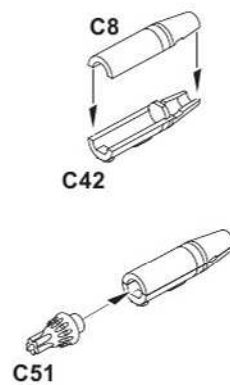

R-60
2 pcs.

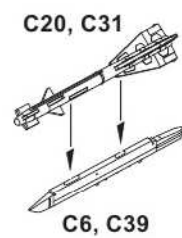

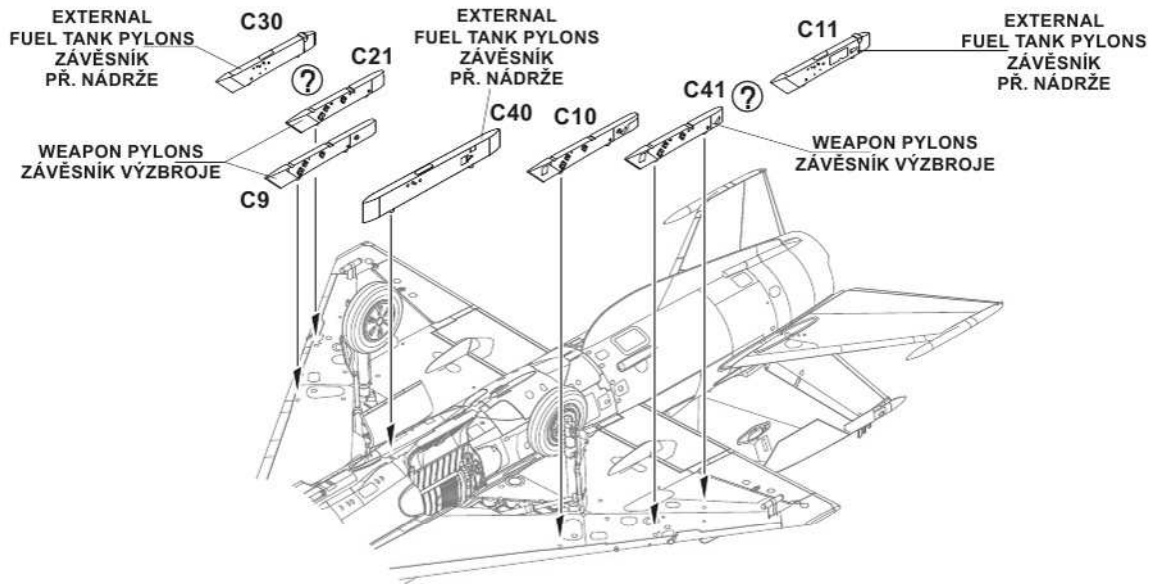

TYPICAL ARMAMENT AND FUEL TANKS OPTIONS

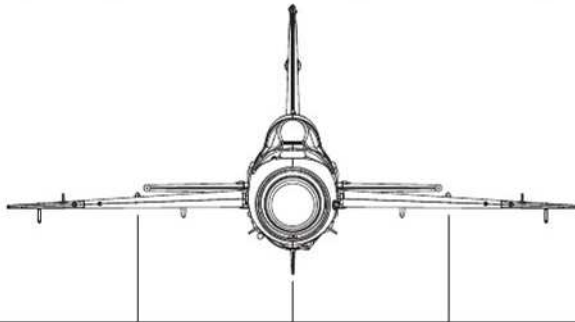

EXTERNAL FUEL TANK 800I	C40
EXTERNAL FUEL TANK 490I	C40
EXTERNAL FUEL TANK 490I	C11 C30

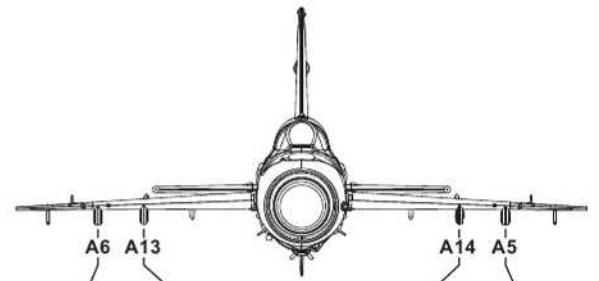

S-24	C38 ? C38	C38 ? C38
RS-2US	C38 ? C38	C38 ? C38
R-3S	C5 ? C5	C45 ? C45
R-13	C23 ? C23	C28 ? C28
R-60	C6	C39
FAB 250 BOMB	? ?	? ?
UB-16	● ●	● ●

TO CHOOSE WEAPON AND EXTERNAL FUEL TANK OPTION PLEASE FOLLOW YOUR REFERENCE.

PRO VOLBU VÝZBROJE A PŘÍDAVNÝCH NÁDRŽÍ SE DRŽTE DOKUMENTACE KONKRÉTNÍHO STROJE.

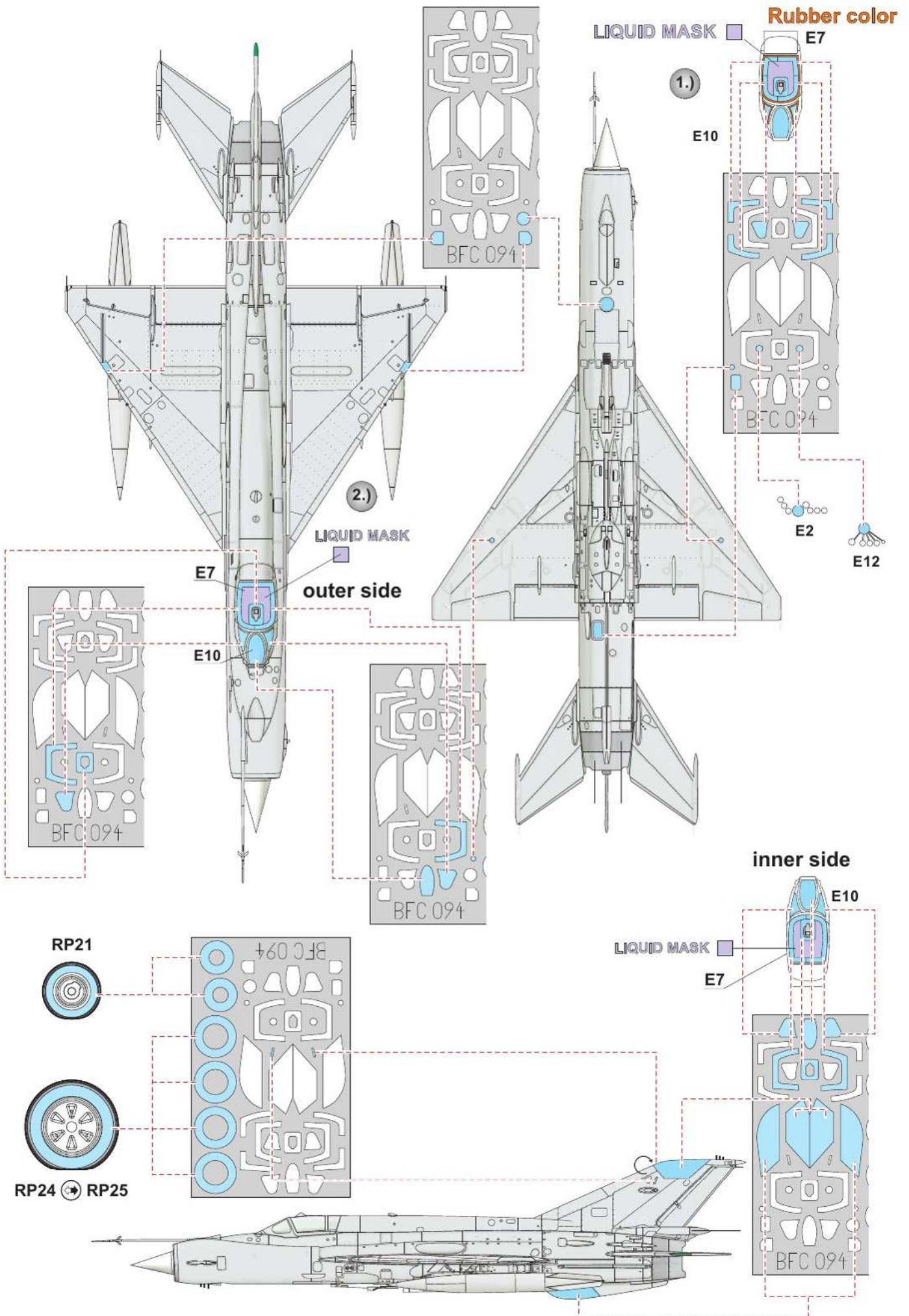

A MiG-21BFC, flown by Lt. C. Bunnyfield, 1st Squadron, Carrot Flight, Central Africa, July 2011

This aircraft took part in one of the lesser known conflicts, the so-called 'Carrot War'. This local war occurred in Central Africa, totally out of the global media focus. The core of the war was the ownership of local carrot fields. The MiG-21BFC (Bomber – Fighter – Canibalized) was sold to Central Africa from former Czech Air Force stock, so the Czech low-vis national insignia were visible on the wings during the early stages of the Carrot War. Three kill marks below the cockpit symbolize enemy aircraft downed by Lt. Carrol Bunnyfield. The unusually colorful camouflaged MiG served as bait for enemy opportunists. Enemy aircraft were jumped by other MiGs when trying to destroy Bunnyfield's aircraft.

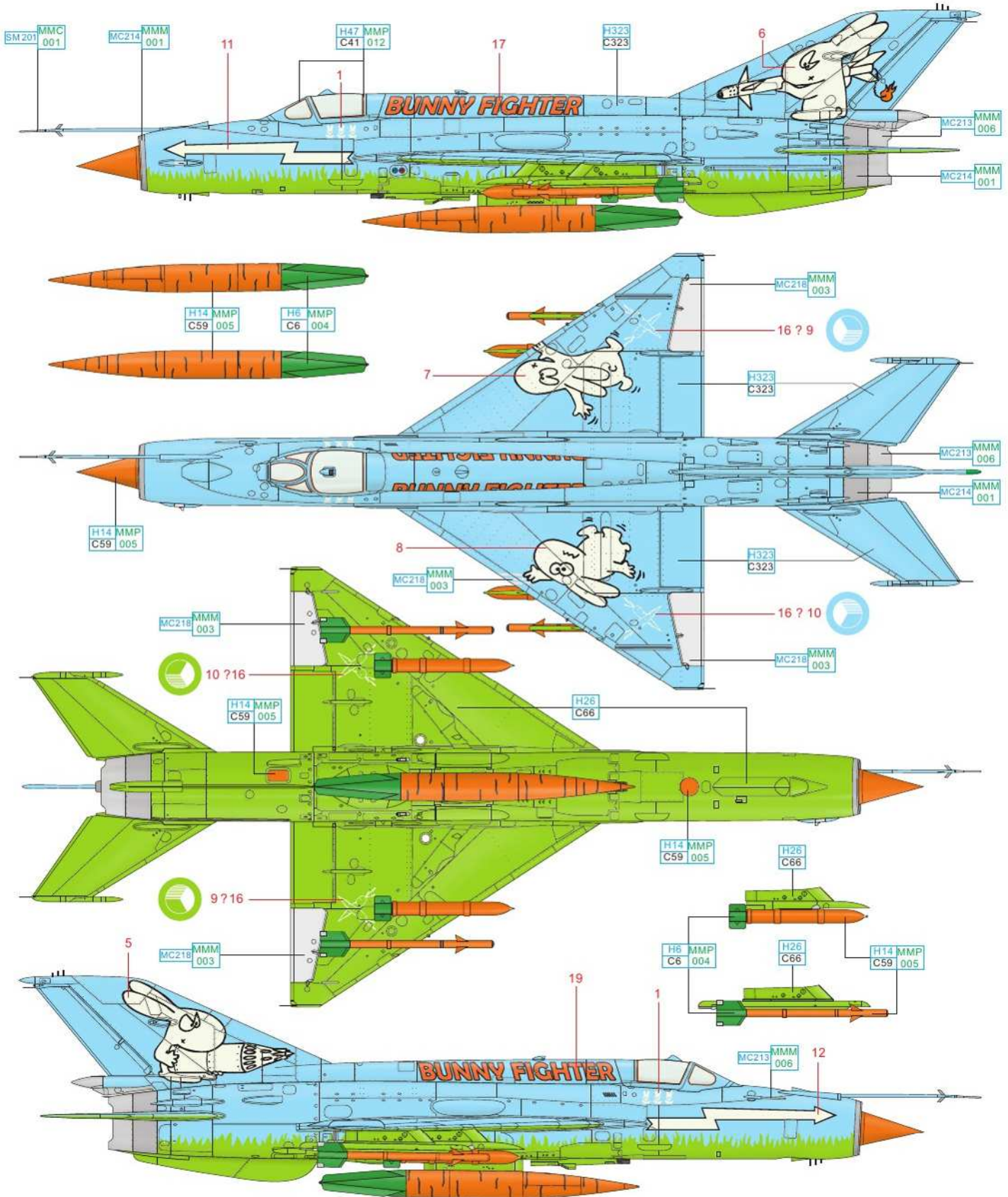

SUPER FINE SILVER	SM201	MMC001	DARK IRON	MC214	MMM001	STEEL	MC213	MMM006	ALUMINIUM	MC218	MMM003		
GREEN	H6	MMP C6	004	ORANGE	H14	MMP C59	005	BRIGHT GREEN	H26	C66	LIGHT BLUE	H323	C323

ČESKOU VERZI TEXTU NALEZNETE NA www.eduard.com
POD KATALOGOVÝM ČÍSLEM BFC094



B MiG-21MF, 2nd Squadron, 11th Fighter Regiment, Zatec Air Base, Czechoslovakia, 1991

This aircraft was completed on February 18th, 1972, and was delivered to Czechoslovakia the following year. After brief service with the 4th slp it was transferred to the 5th slp in June, 1972, at Pilsen-Line. Here, it flew until May, 1991, when it was reassigned to the 2nd Squadron, 11th slp, flying out of Zatec. At this time, the right side of the vertical fin recieved the Knight logo of Eduard. The nose of the plane carried the inscription 'Lovec Tygru' (Tiger Hunter), among other small drawings and markings. The author of the artwork was technician Lubos Habl. The inscription 'Tiger Hunter' and the bird of prey carrying a tiger's head in its talons was the result of 'friendly' sparring between two units of the 11th slp. The 1st Squadron, 11th slp used tiger motifs quite openly on their MiG-29s.

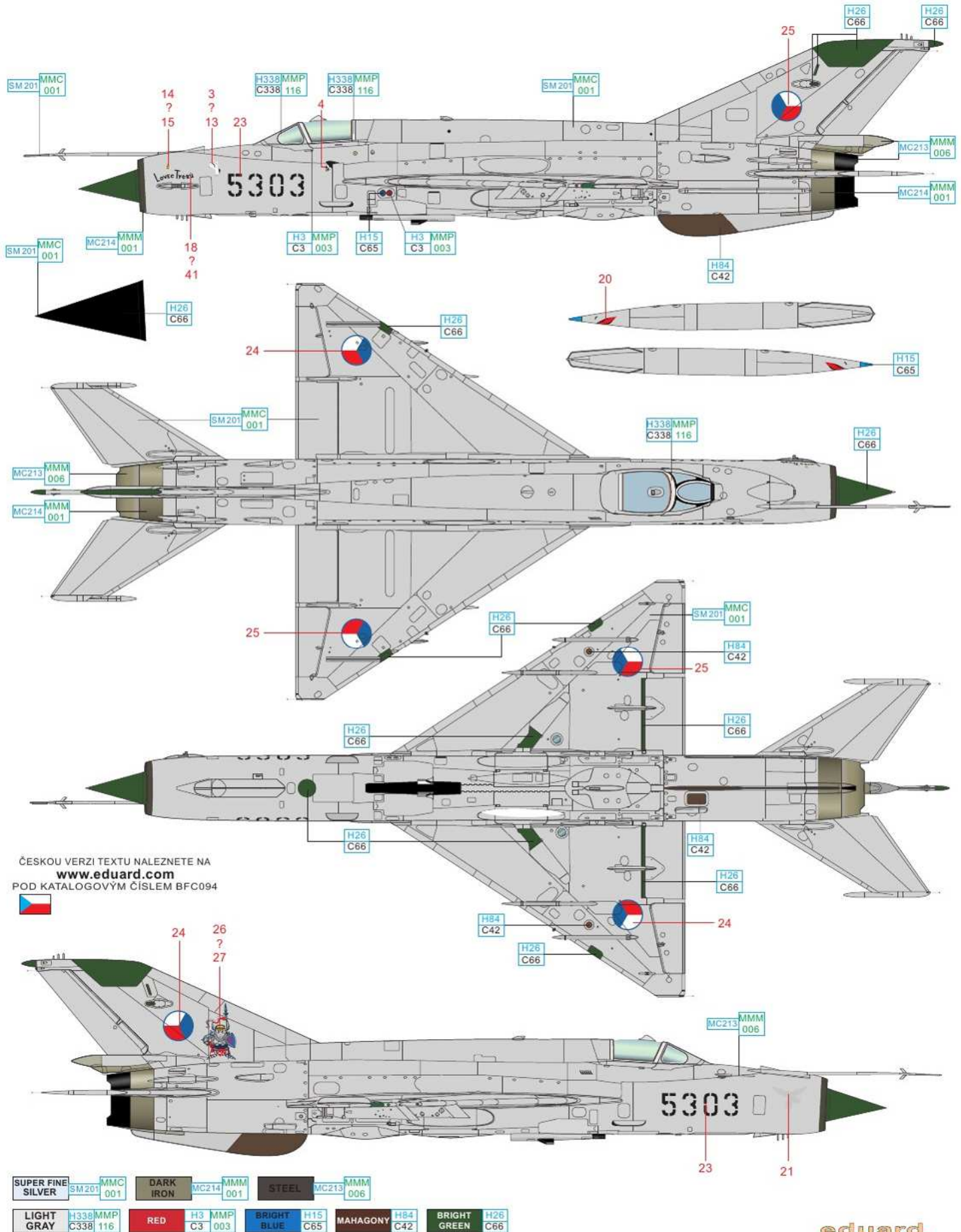

ČESKOU VERZI TEXTU NALEZNETE NA
www.eduard.com
 POD KATALOGOVÝM ČÍSLEM BFC094



SUPER FINE SILVER	SM201	MMC 001	DARK IRON	MC214	MMM 001	STEEL	MC213	MMM 006
LIGHT GRAY	H338MMP	C338 116	RED	H3	MMP C3 003	BRIGHT BLUE	H15	C65
						MAHAGONY	H84	C42
						BRIGHT GREEN	H26	C66



C MiG-21M, 1st Squadron, 4th Fighter Air Regiment, Pardubice air base, June 1989

The relaxing of the political strictness through 1989, along with the disbandment of Pardubice's 4th slp, gave rise to something as yet unheard of. Two more or less clothed ladies graced the noses of a MiG-21M. Greater scorn was provoked by the markings denoting 'Pardubice' and '4.slp' (translator's note: typically, the period behind the number is the equivalent to the English 'st', 'th' or 'nd', so that the 4. is equivalent to 4th, the 1. to the 1st, and so on), since these bits of information were still strictly classified. The inspiration for the artwork on '1113' was pin up on B-24 „Barbara Jean“ from the Second World War. The image was projected and transferred onto the aircraft with the use of a Meotax apparatus, and this aircraft made it into the air at least once with the pin-up in place. These aircraft were updated to MF standard likely during their general overhaul in 1987. They were given the rear view periscope mounted in the canopy and had the small wing fences added adjacent to the auxiliary air intake doors. The R-13 power egg was added already during the midlife upgrade. Aircraft after general overhauls in April 1986, retained their original look without paint, the wheel wells were a grey-green color, and the air brake interiors were painted their usual dense yellow color.

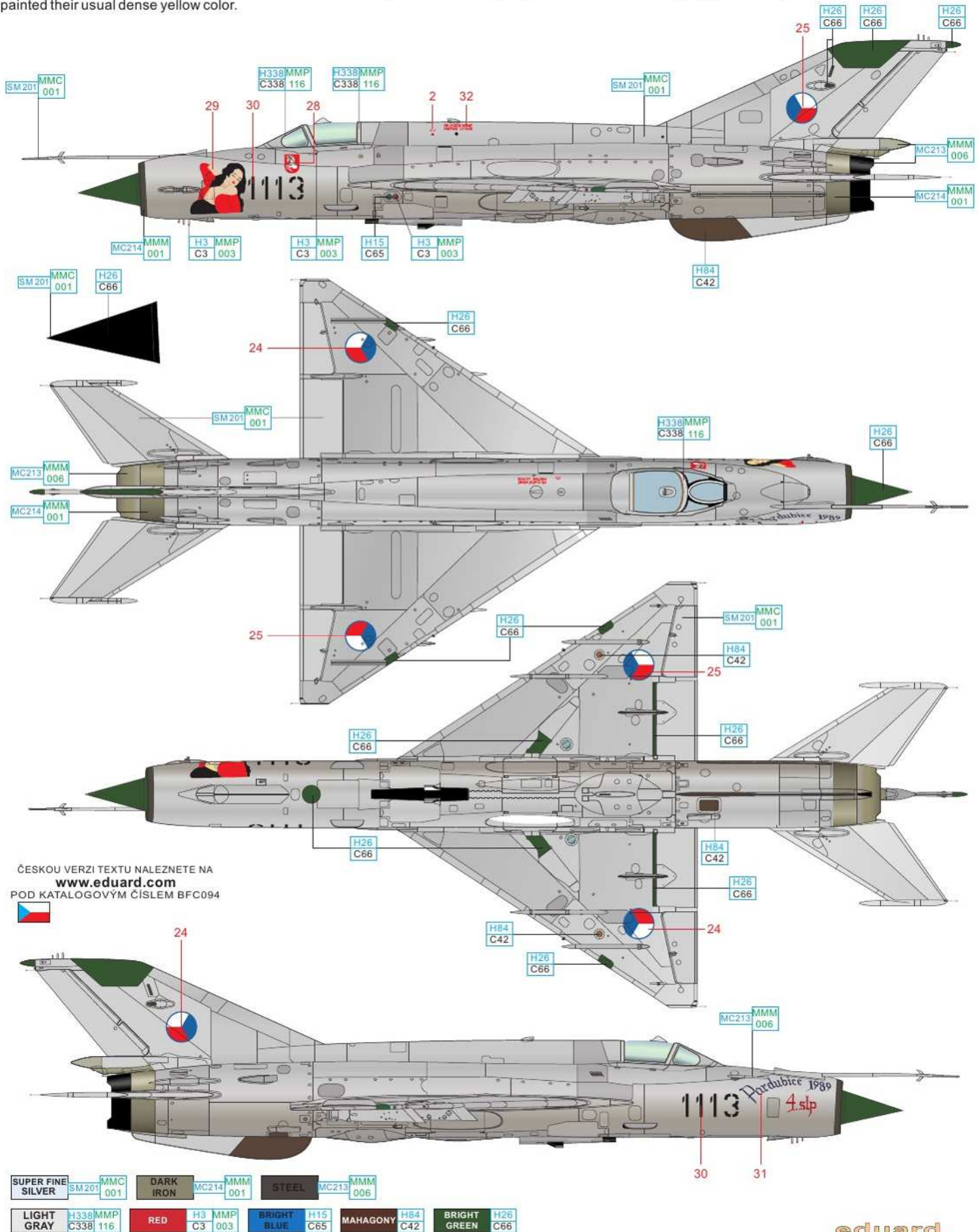

D No. 127, 812th Training Air Regiment, Kharkov Higher Military Aviation School of Pilots, Kupyansk Airfield, Soviet Union, August 1991

This aircraft, adorned with a sharkmouth and eyes, served with the 812. UAP (812th Training Air Regiment) operating within the structure of the Kharkov higher training facility. This was one of the aircraft that were displayed for the leadership during the open house on August 18th, 1991.

STENCILS: blue variant

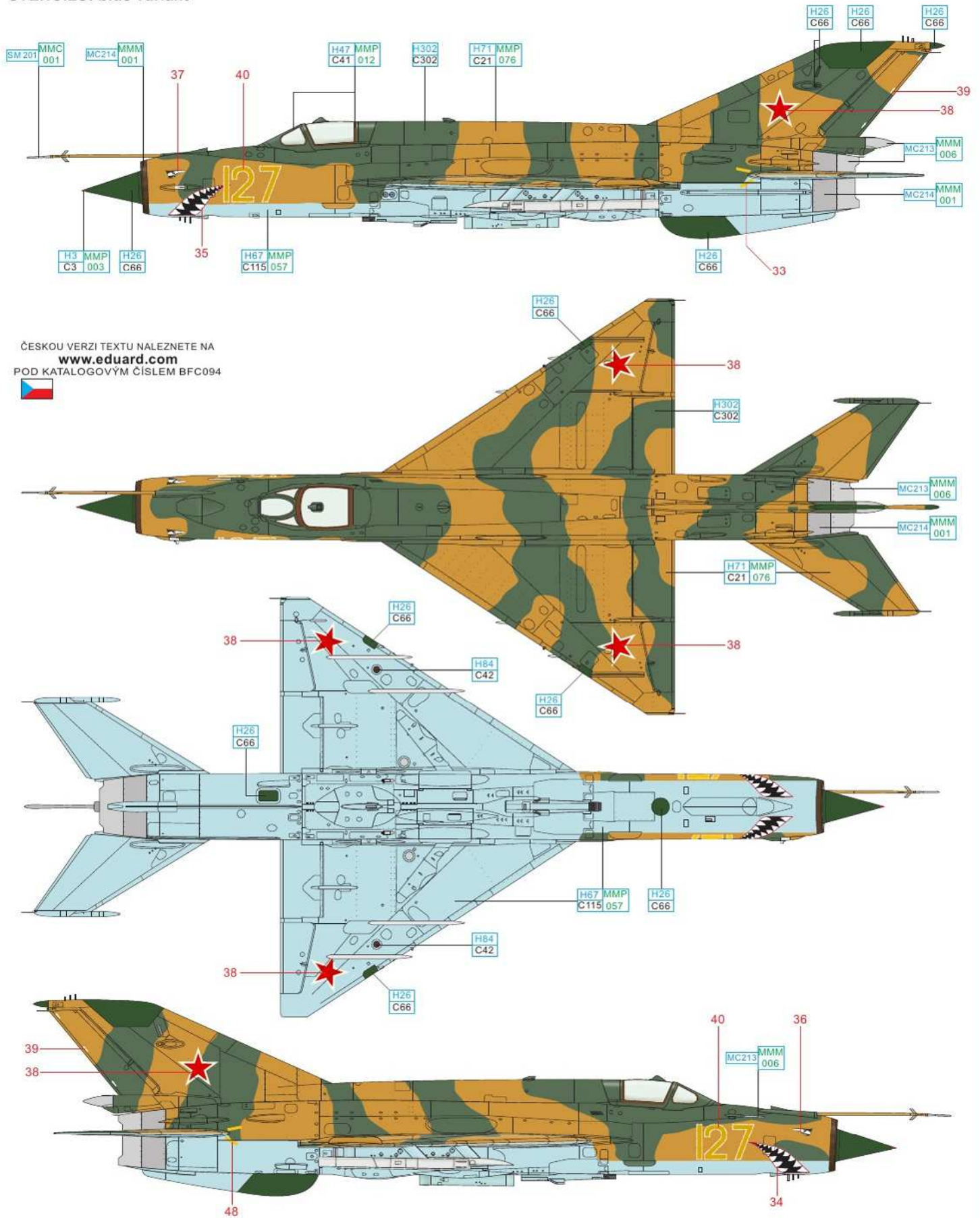

ČESKOU VERZI TEXTU NALEZNETE NA
www.eduard.com
 POD KATALOGOVÝM ČÍSLEM BFC094



SUPER FINE SILVER	SM201	MMC 001	STEEL	MC213	MMM 006	DARK IRON	MC214	MMM 001	RED	H3	MMP C3 003
RED BROWN	H47	MMP C41 012	MIDDLE STONE	H71	MMP C21 076	LIGHT BLUE	H67	MMP C115 057	GREEN	H302	C302
	MAHOGANY	H84	C42	BRIGHT GREEN	H26	C66					

LEVÝ
VNĚJŠÍ PODKŘÍDLOVÝ
PALIVOVÝ PYLON
LEFT OUTSIDE
UNDERWING TANK PYLON

SN - SERIOVÁ ČÍSLA
MALÉ NA DRÁK LETOUNU
STŘEDNÍ NA ZÁVĚSNÍKY
VELKÉ NA RAKETNICE

SN - SERIAL NUMBER
SMALL FOR AIRFRAME
MEDIUM FOR PYLONS
LARGE FOR ROCKET LAUNCHERS

PRÁVÝ
VNĚJŠÍ PODKŘÍDLOVÝ
PALIVOVÝ PYLON
RIGHT OUTSIDE
UNDERWING TANK PYLON

PODTRUPOVÝ PYLON
FUSELAGE PYLON

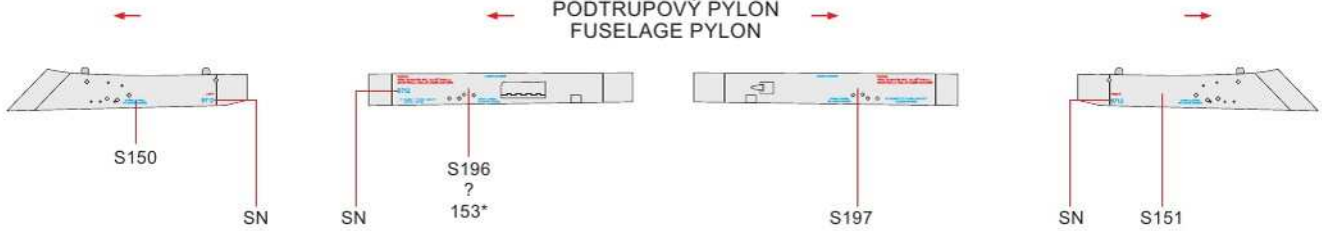

LEVÝ VNĚJŠÍ PYLON
LEFT OUTSIDE PYLON

PRÁVÝ VNĚJŠÍ PYLON
RIGHT OUTSIDE PYLON

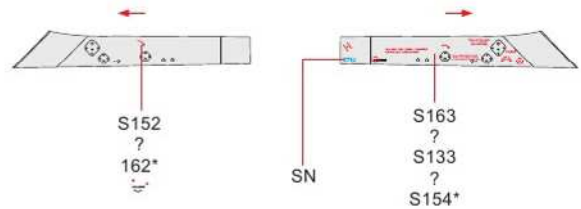
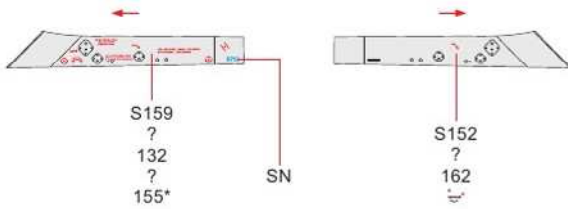

LEVÝ VNITŘNÍ PYLON
LEFT INSIDE PYLON

PRÁVÝ VNITŘNÍ PYLON
RIGHT INSIDE PYLON

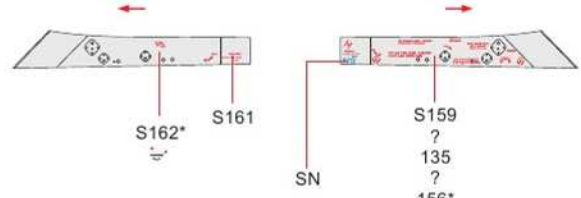
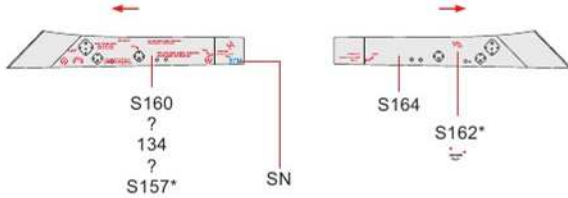

APU-7

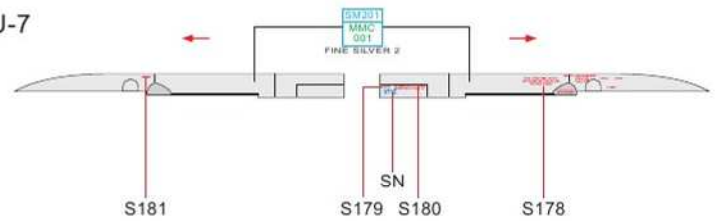
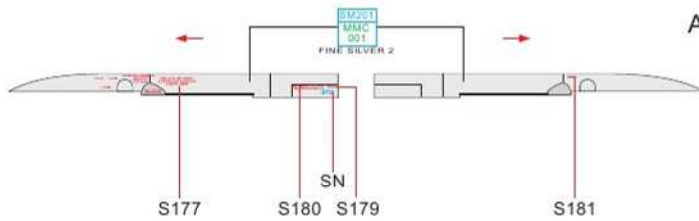

APU-13

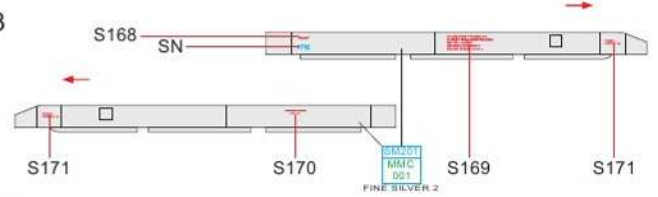
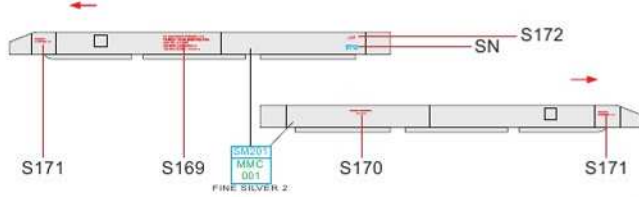

APU-13MT

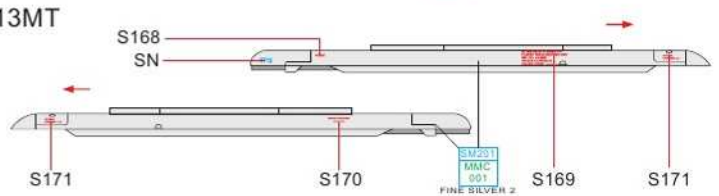
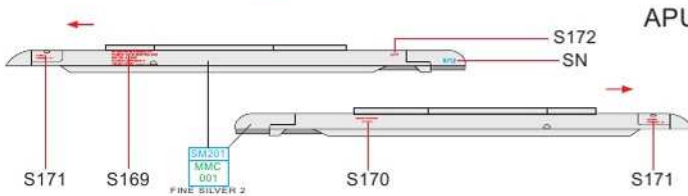

APU-13

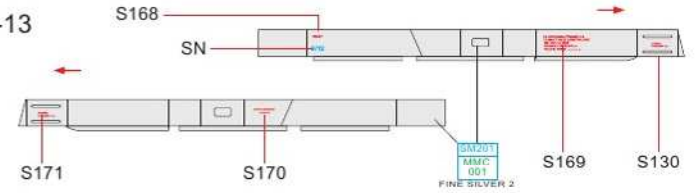
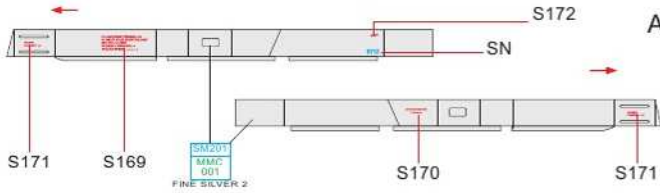

APU FOR R-60

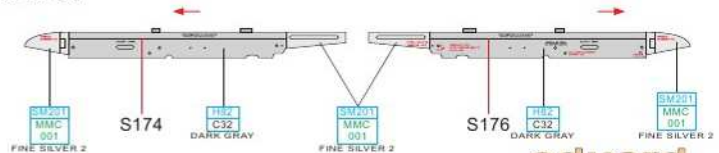
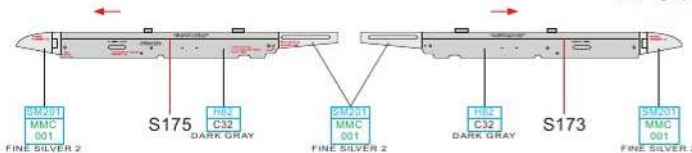

UB-16

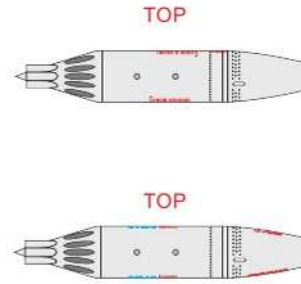
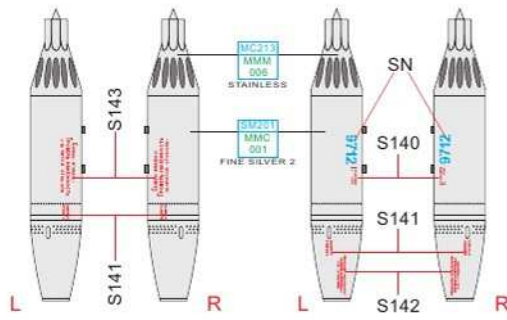

RS-2US

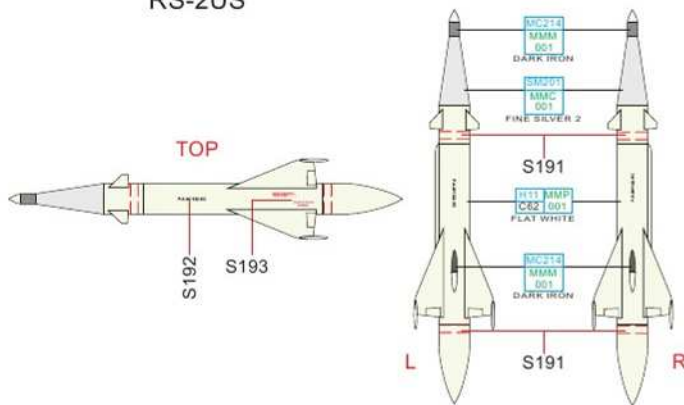

S-24

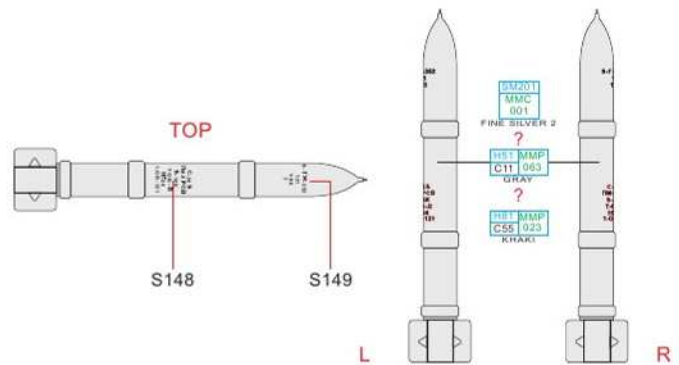

R-3S

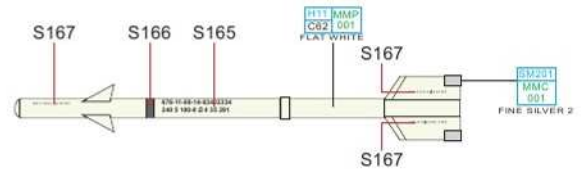
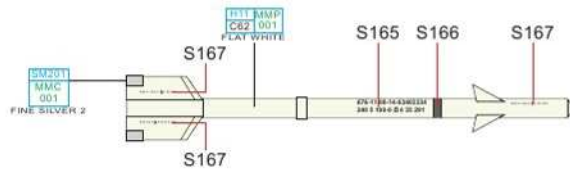

R-13

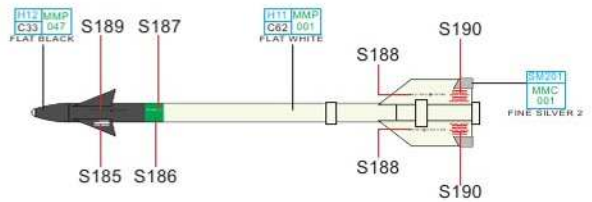
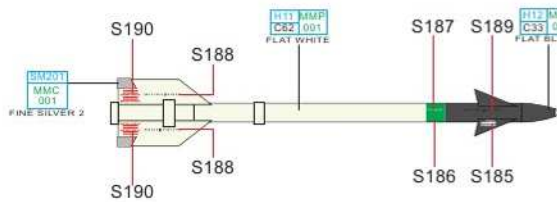

R-60

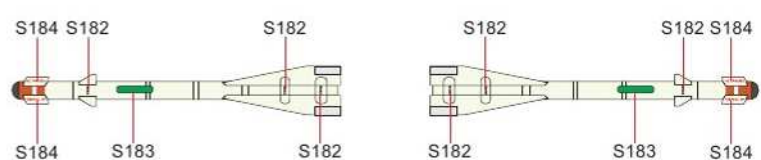
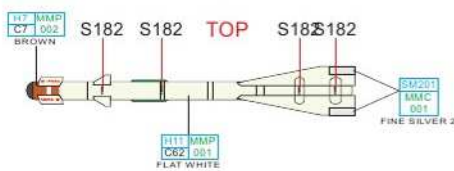

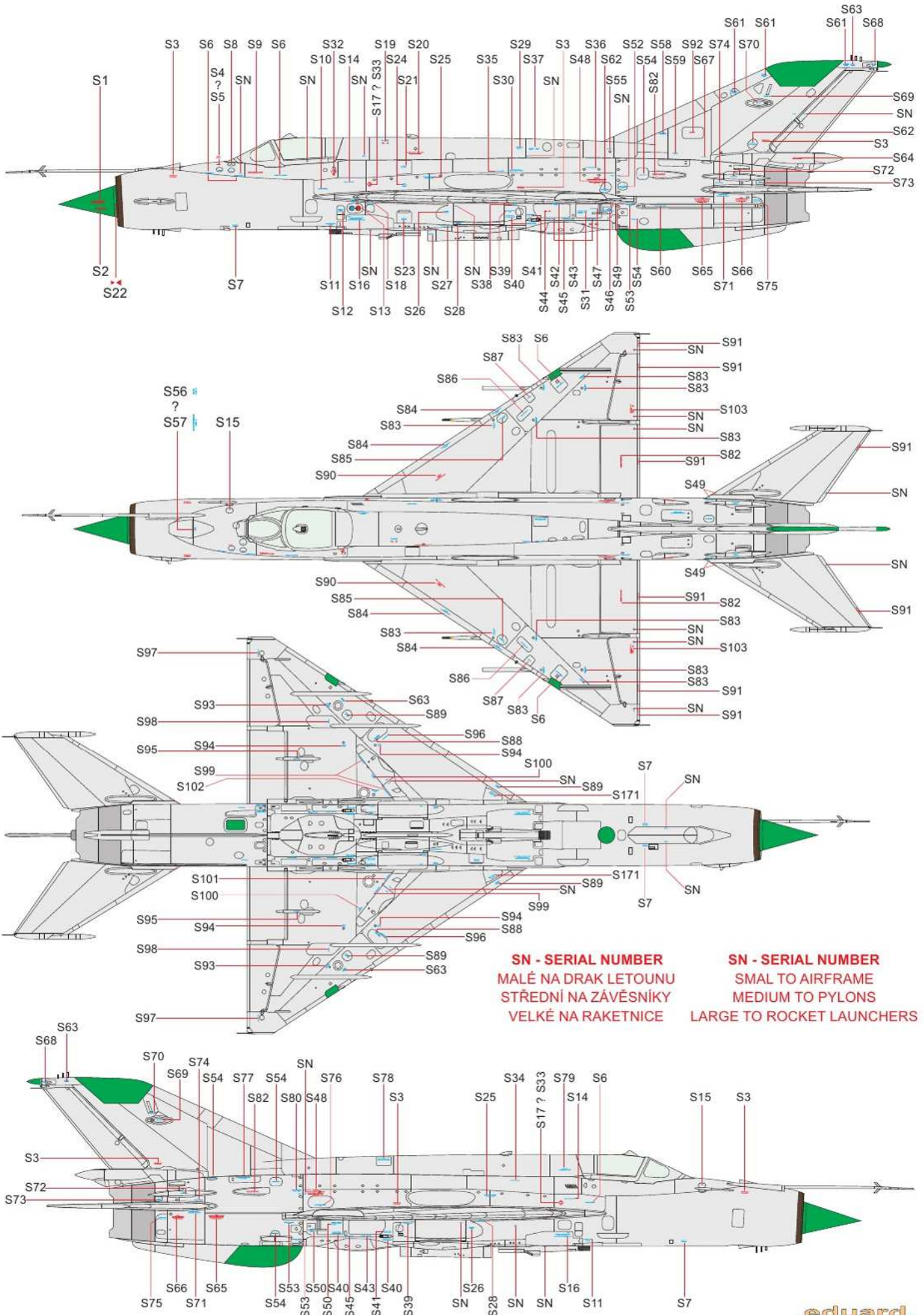

SN - SERIAL NUMBER
MALÉ NA DRÁK LETOUNU
STŘEDNÍ NA ZÁVĚSNÍKY
VELKÉ NA RAKETNICE

SN - SERIAL NUMBER
SMAL TO AIRFRAME
MEDIUM TO PYLONS
LARGE TO ROCKET LAUNCHERS

RELATED PRODUCTS for MiG-21MF:

72689 MiG-21MF 1/72 (PE-Set)

Cat. No. 672193

672184 MiG-21MF pylons 1/72 (Brassin)

672185 R-3S missiles for MiG-21 1/72 (Brassin)

672186 R-3S missiles w/ pylons for MiG-21 1/72 (Brassin)

672187 R-13M missiles for MiG-21 1/72 (Brassin)

672188 R-13M missiles w/ pylons for MiG-21 1/72 (Brassin)

672189 UB-16 rocket launchers for MiG-21 1/72 (Brassin)

672190 UB-16 rocket launchers w/ pylons for MiG-21 1/72 (Brassin)

672191 RS-2US missiles for MiG-21 1/72 (Brassin)

672192 RS-2US missiles w/ pylons for MiG-21 1/72 (Brassin)

672193 MiG-21MF airbrakes 1/72 (Brassin)



Cat. No. 672191

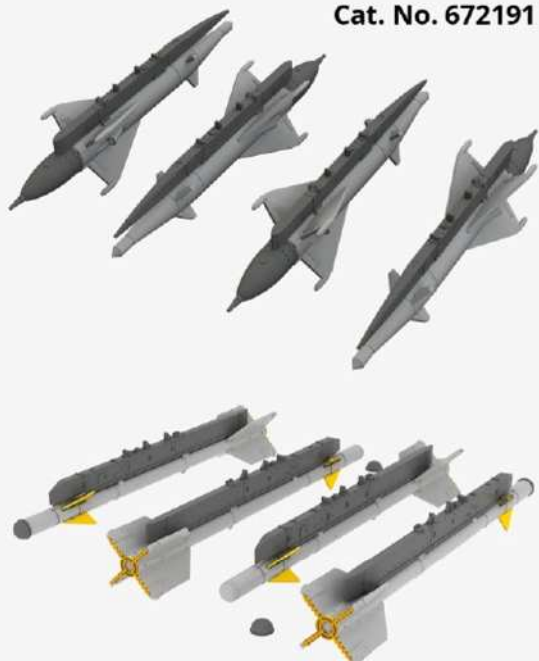

Cat. No. 672188



Cat. No. 672185



Cat. No. 672189