



LIMITED EDITION

SOVA-M
SVM-14017

GA-43
Clark



UNASSEMBLED PLASTIC MODEL KITS

SCALE:1/144

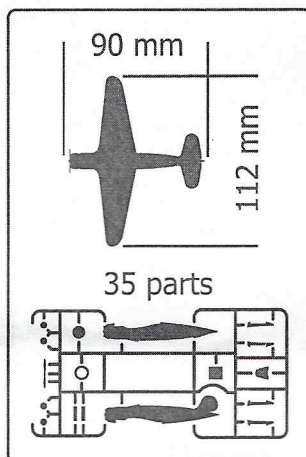

DECALS

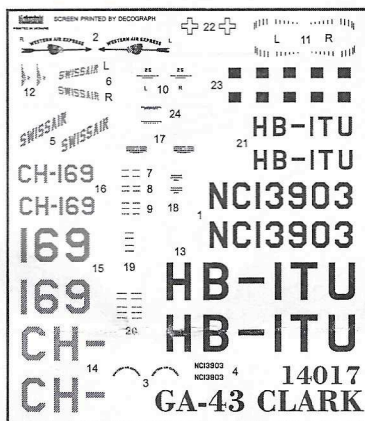







THREE VERSIONS OF COLOURING

In 1930, General Aviation designed a 10-seat passenger aircraft, designated as General Aviation G.A.43. The maiden flight of the prototype aircraft (NX775N) took place on 22nd of May, 1932. For the early 1930s, the aircraft had very advanced onboard equipment, which included a full set of flight instruments for "Non-visual" flight, radio and transmitting equipment, as well as a short-wave receiver for promptly receiving weather forecasts and radio beacon signals. Sadly, the plane did not reach commercial success – only five machines of that type were built.

The model is executed on technology short run and is intended only for experienced modelers.

Word-wide distributor for Sova-M kits:
ModelSvit Balkans Ltd. 4003 Plovdiv,
Bulgaria 9, zk Maritza Gardens.
Tel. +359 32 397 069,
E-Mail: modelsvitbalkans@gmail.com
MADE IN UKRAINE

PAINTS

- | | |
|---|--|
| A  HUMBROL 27002 POL. ALUMINIUM | B  HUMBROL 33 BLACK |
| C  HUMBROL 145 MEDIUM GREY | D  HUMBROL 27004 GUN METAL |
| E  HUMBROL 113 RUST | F  HUMBROL 56 ALUMINIUM |
| G  HUMBROL 19 RED | |

SYMBOLS

- | | | |
|--|---|---|
| 1 STAGES OF ASSEMBLY |  TO PAINT |  TO BEND |
| 1 NUMBER PARTS |  GLUE |  SCRATCH BUILT |
|  APPLY DECALS |  DON'T GLUE |  OPEN HOLE |
| x2 QUANTITY OF OPERATIONS |  НА ВИБІР OPTIONAL |  CAT OUT |

SET OF THE PARTS

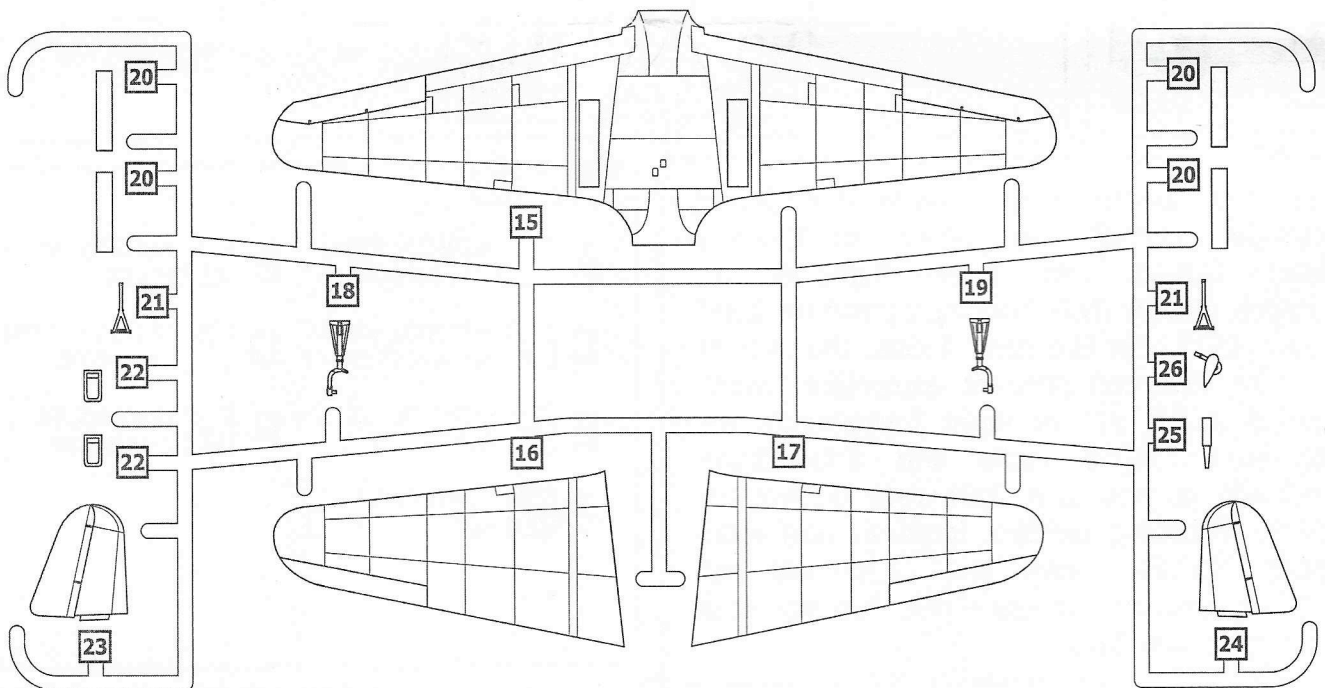
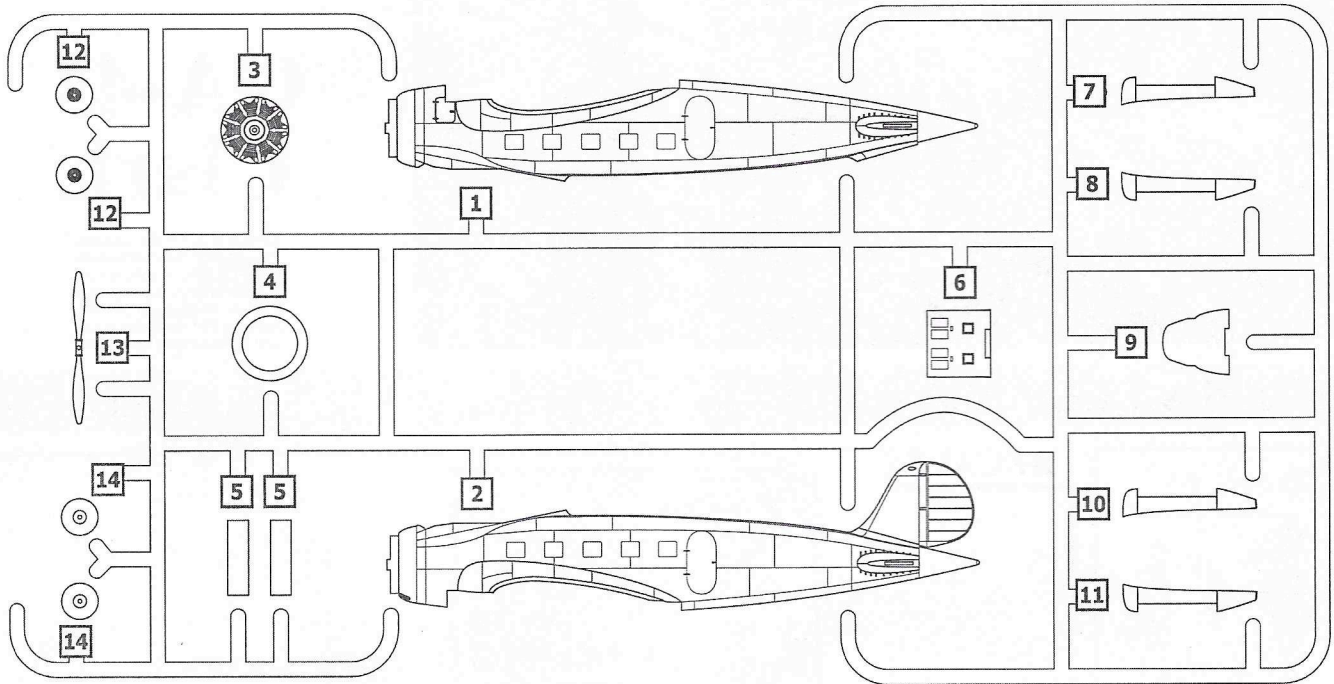

ASSEMBLY INSTRUCTION



- 1**
- 6**
- 9**
- 22** x2

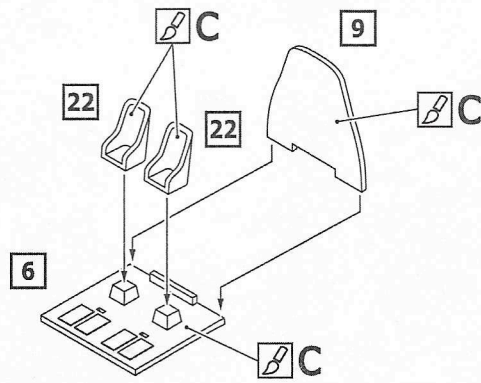

- 2**
- 1**
- 1**
- 2**
- 27**

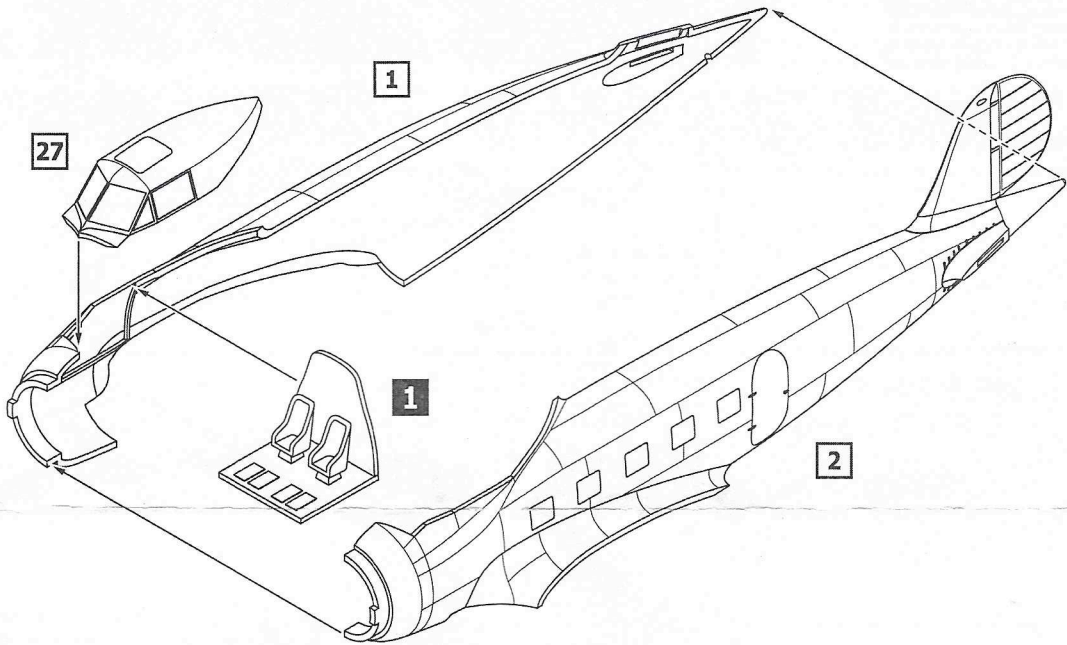

- 3**
- 2**
- 3**
- 4**
- 5** x2
- 13**

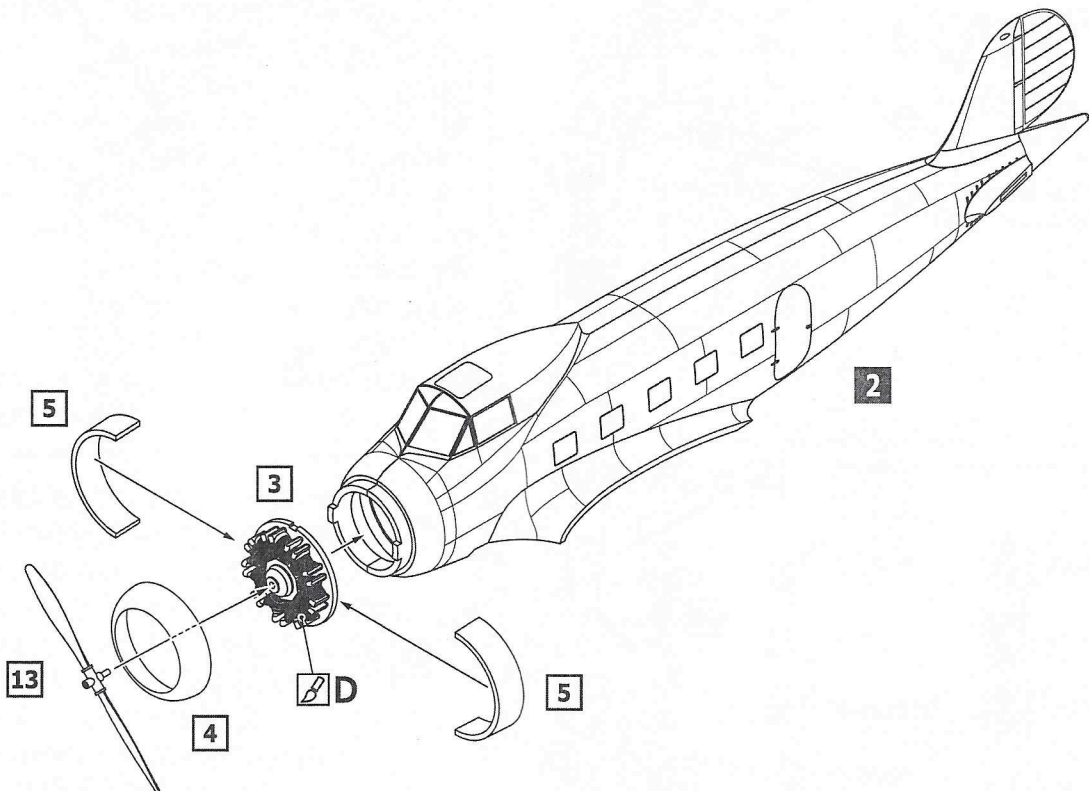

ASSEMBLY INSTRUCTION



- 4
- 3
- 15
- 16
- 17
- 23
- 24

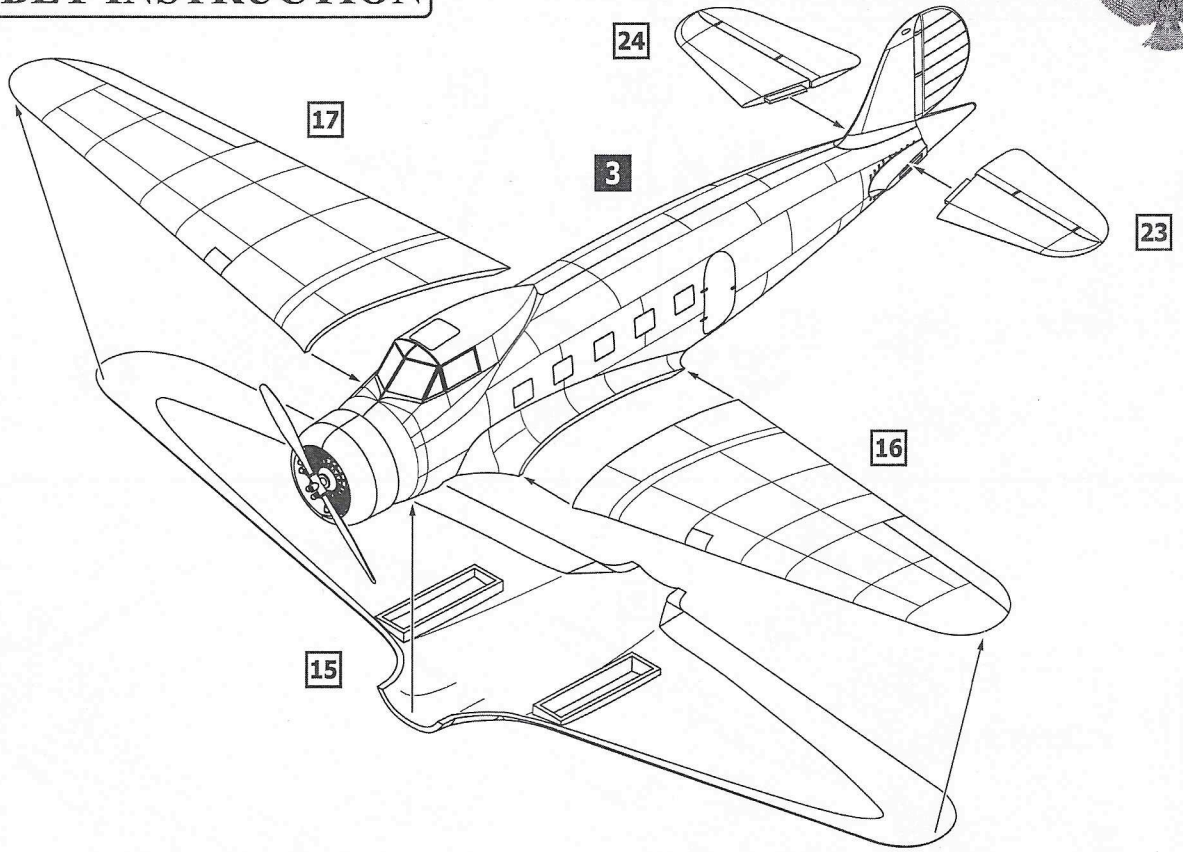

- 5
- 4
- 7
- 8
- 10
- 11
- 12 x2
- 14 x2
- 18
- 19
- 20 x4
- 21 x2
- 25
- 26

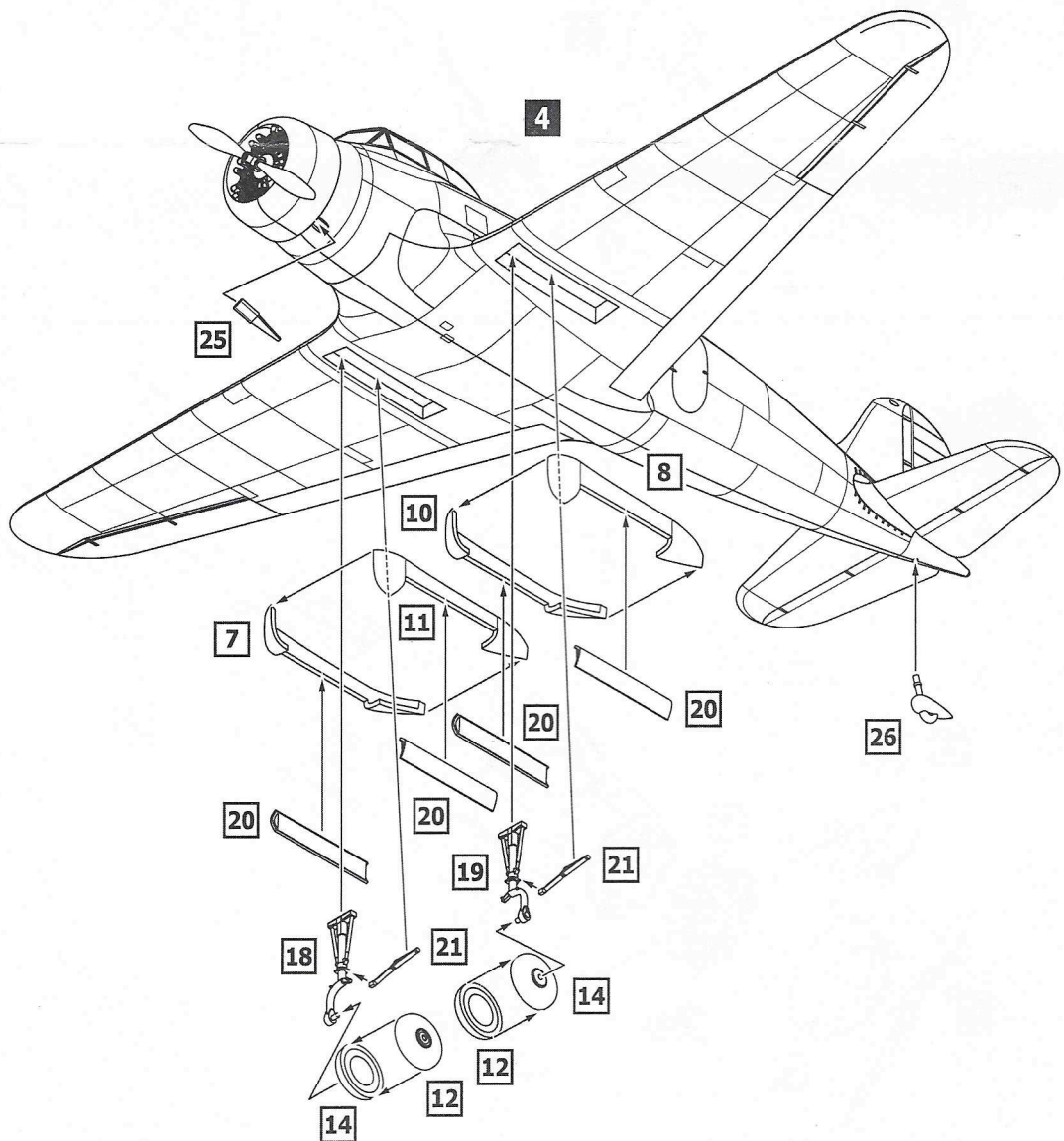

MARKING & PAINTING

GA-43 Clark

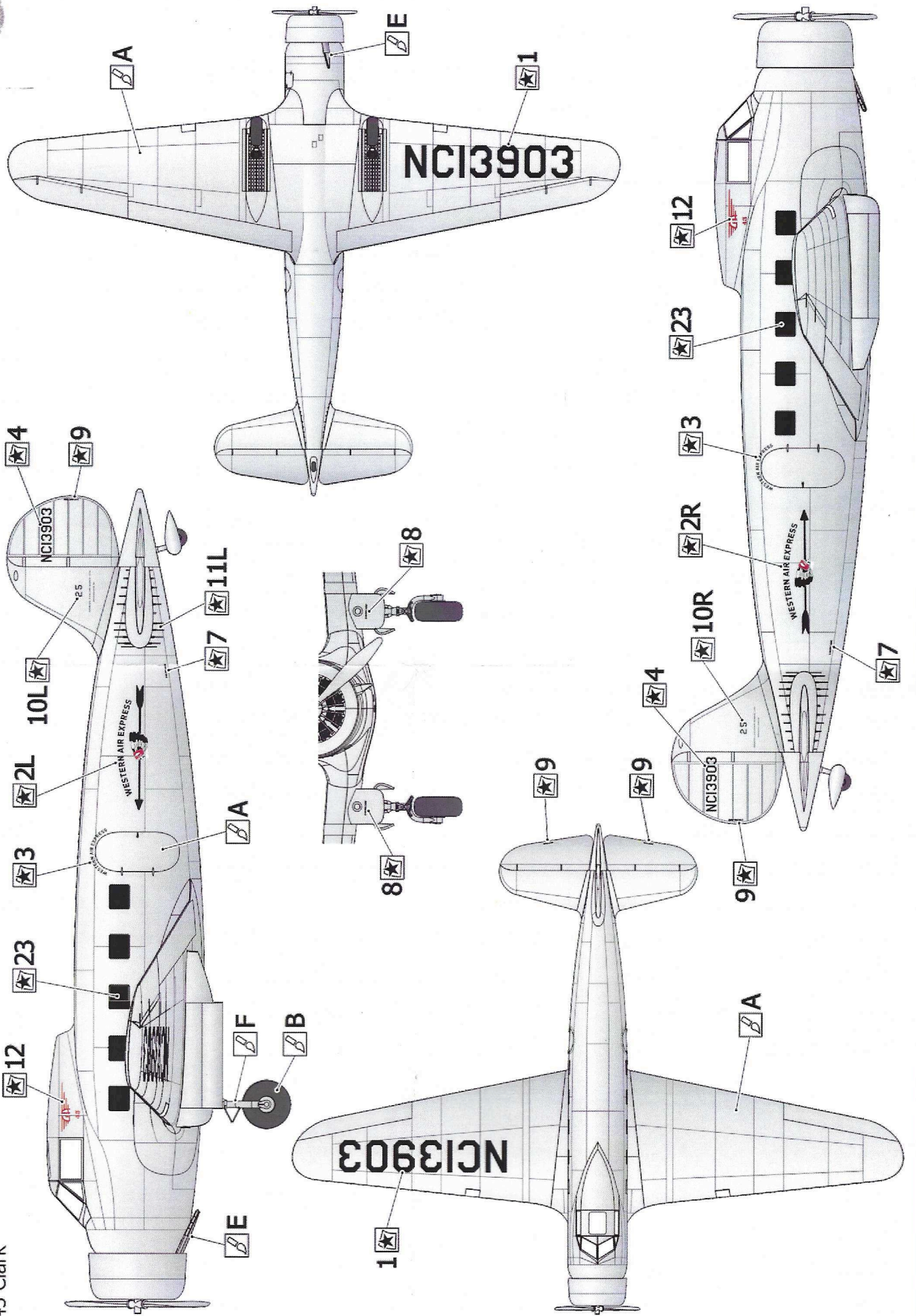

MARKING & PAINTING

GA-43 Clark

