

Polikarpov R-5

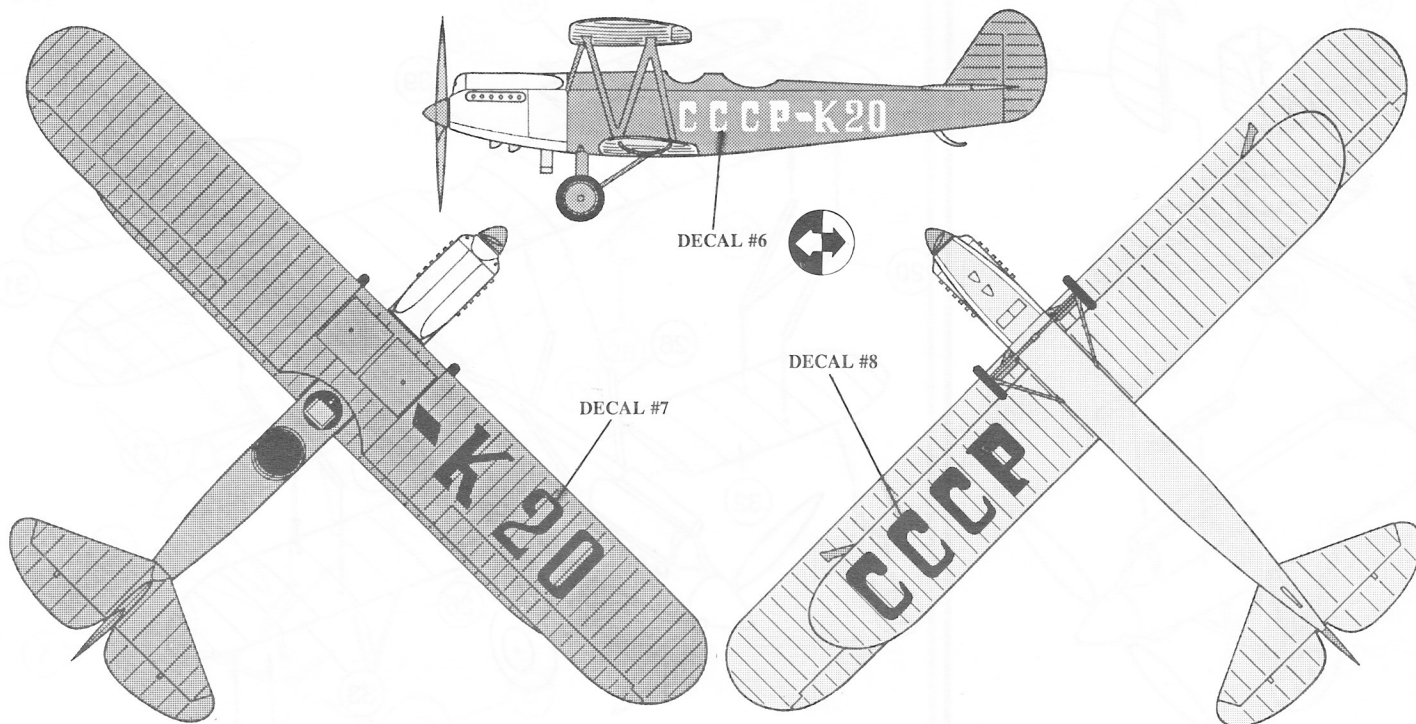

The Polikarpov R-5 light biplane bomber/attack aircraft first entered Soviet service during early 1931 and eventually equipped over 100 regiments of the Soviet Air Force. The aircraft saw service in Spain, where one bomber group arrived in November of 1936, seeing combat as light bombers, night harassment and coastal surveillance aircraft. Soviet R-5's were produced in a number of variants including the R-5a (floats), R-5T (single seat torpedo bomber), and R-5L (enclosed cabin for two passengers). Over 1,000 R-5's were used for civil transports.

An R-5 aircraft in the Light Transport Service (Mid to Late 30's)



Aluminum



Light Blue
FS 35414



Wood
FS 20117



Dark Green
FS 34102



An R-5 aircraft in the Reconnaissance unit of the Red Army Air Force (Mid to Late 30's)

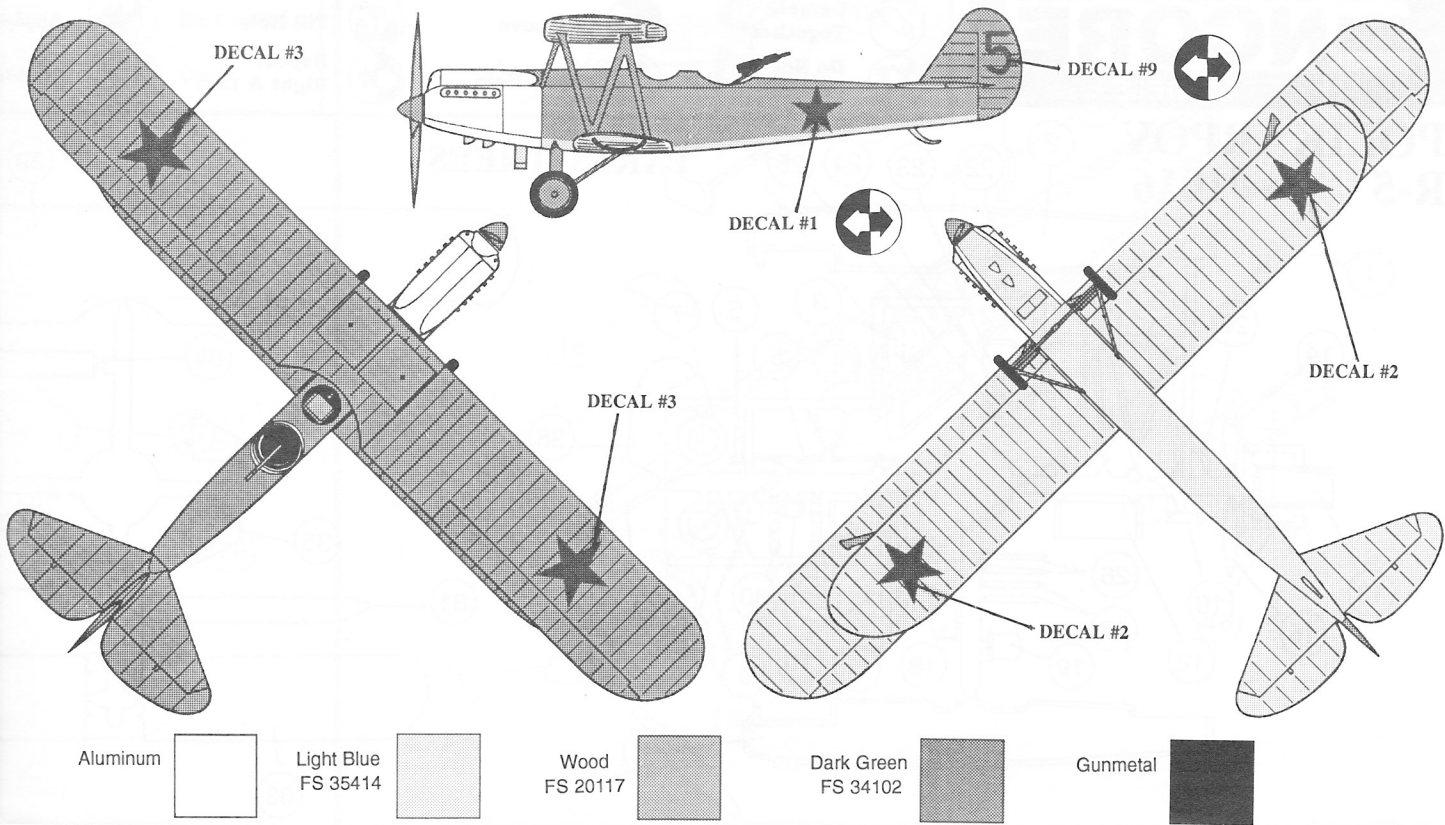

An R-5 aircraft of the Spanish Republican Air Force (1936-1937)

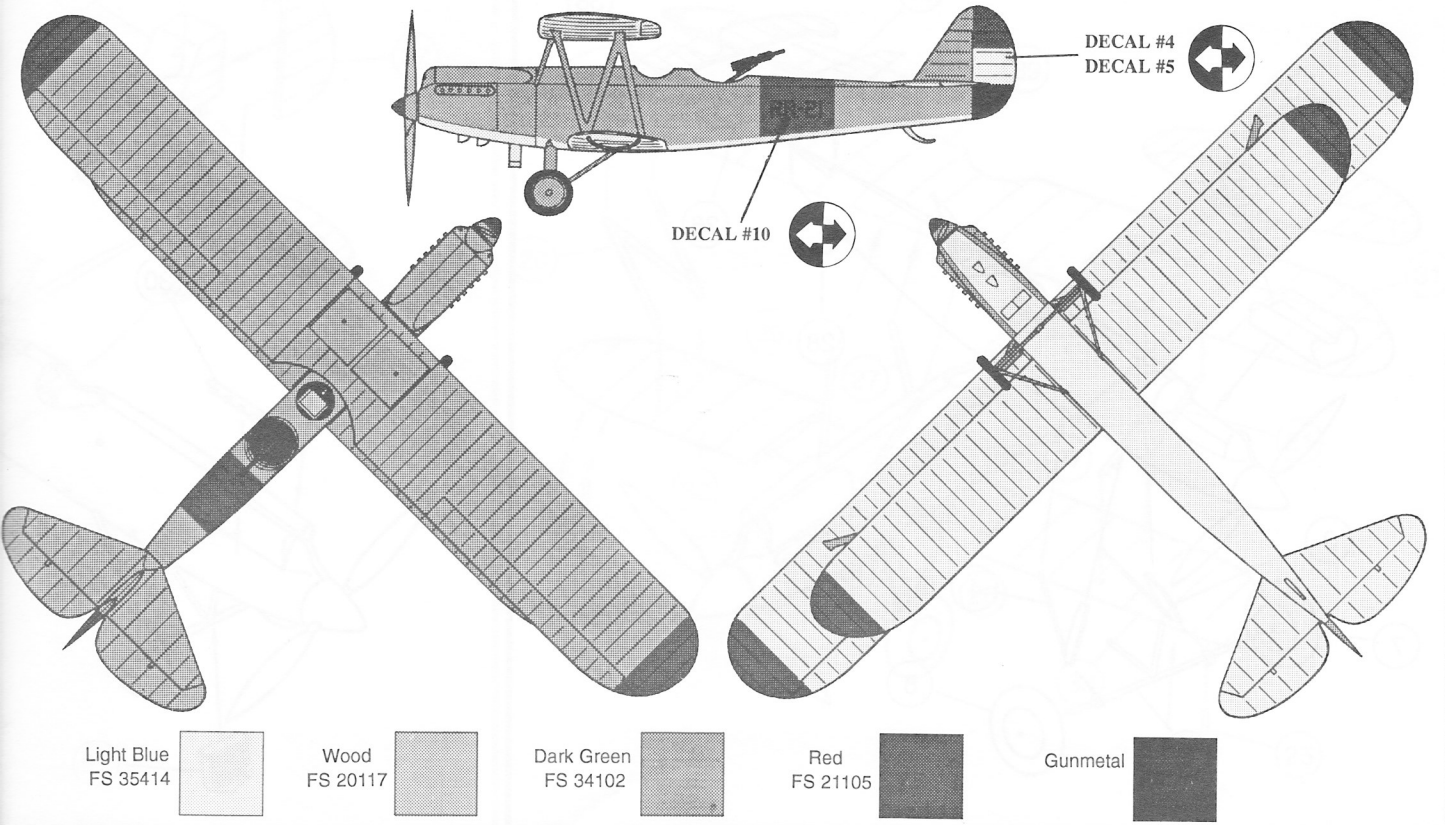

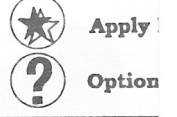

POLIKARPOV R-5 #1016

PARTS TREES

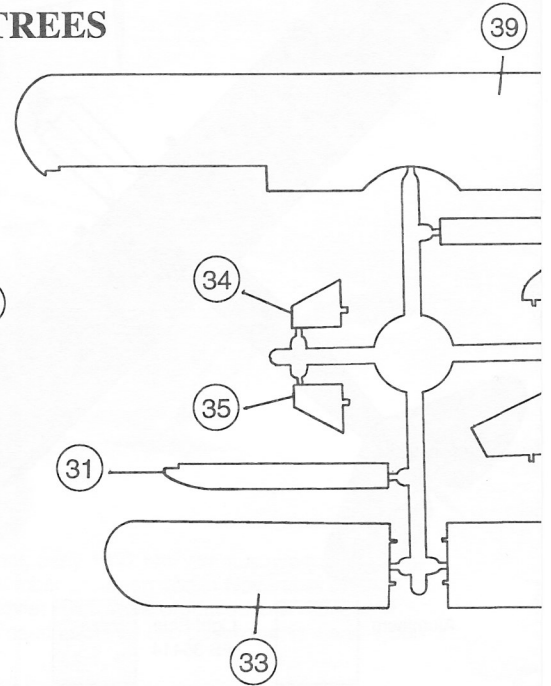
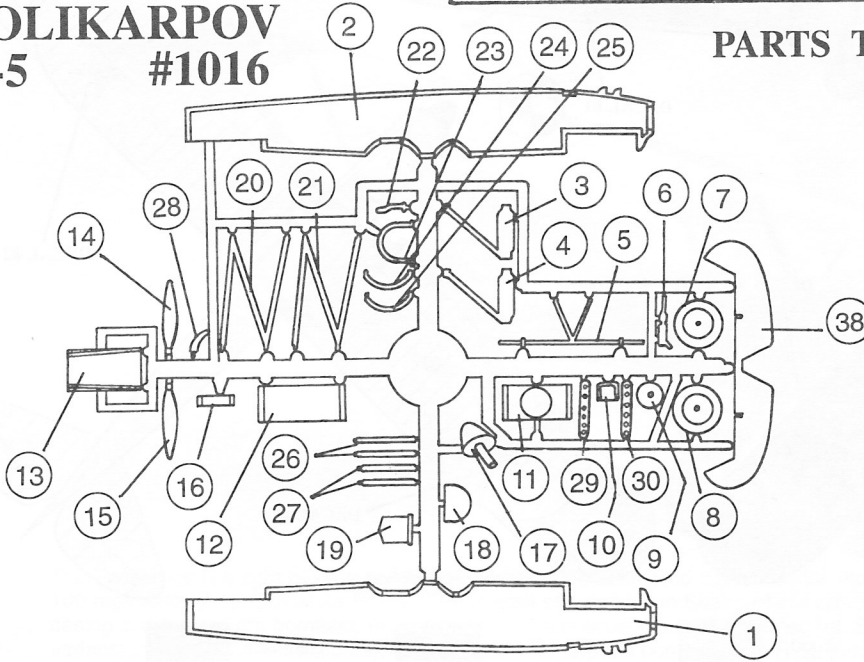

STEP #2

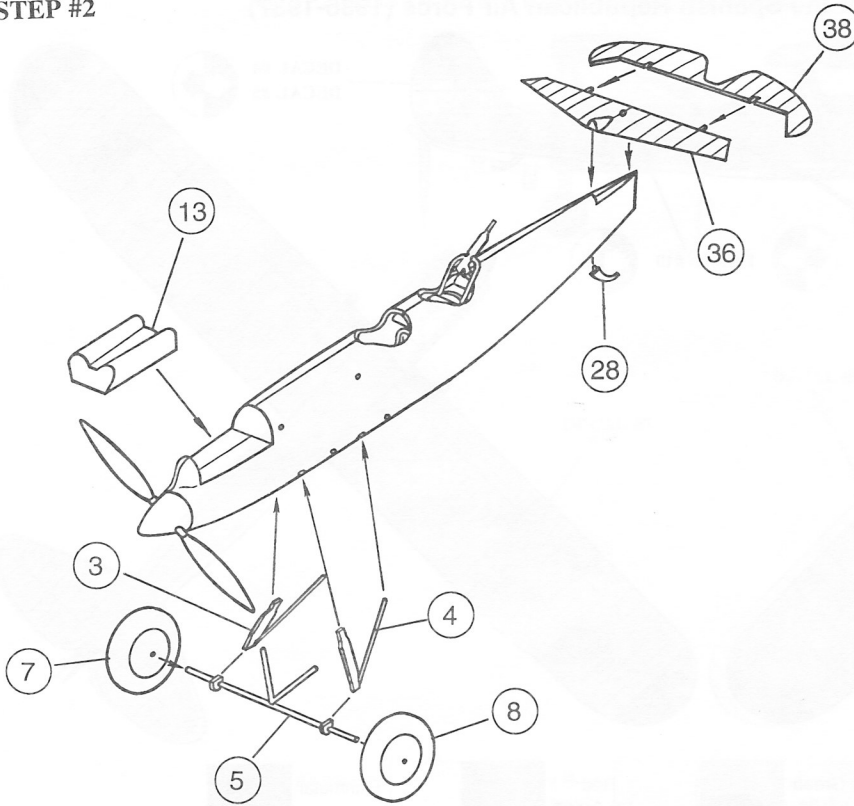

STEP #3

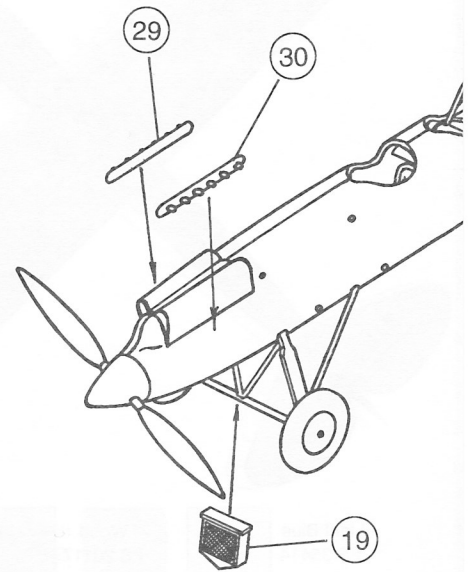

Be Careful
Omit

STEP #1

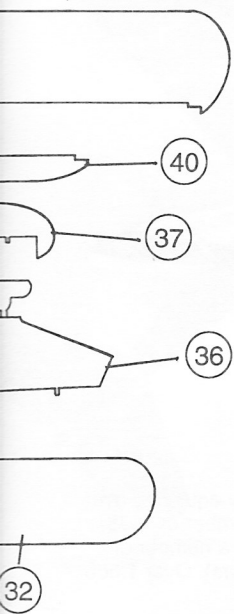
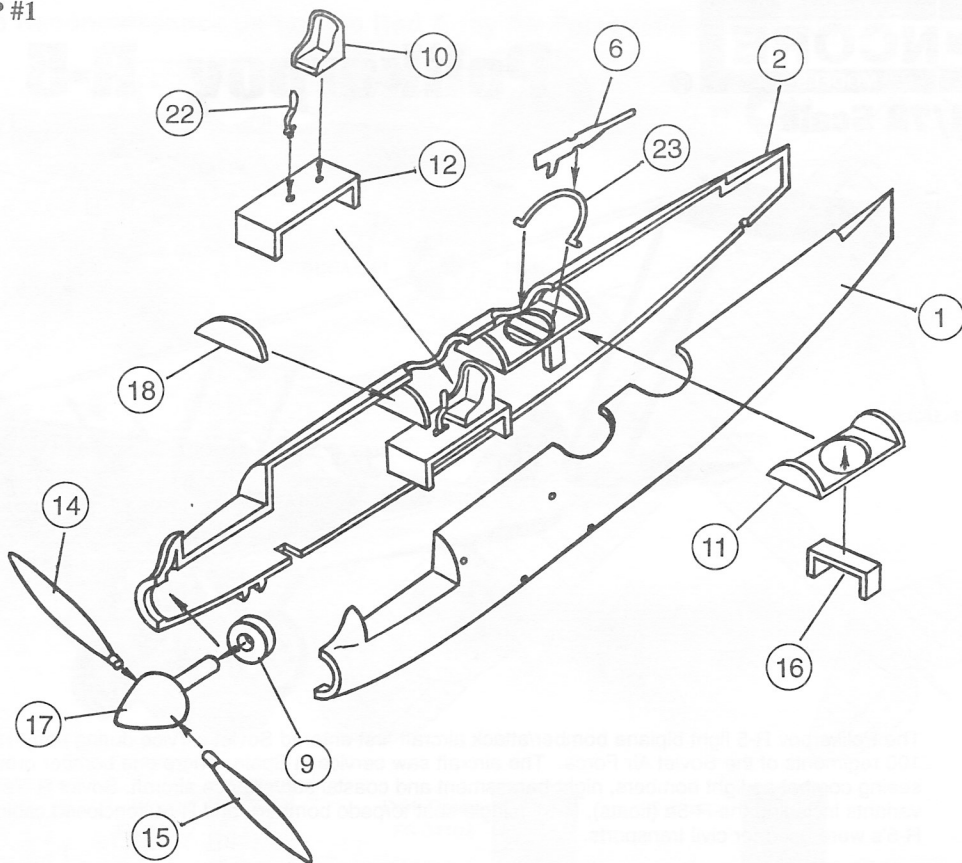

STEP #4 Final Assembly

