

ATTENTION



UPOZORNĚNÍ



ACHTUNG



ATTENTION



注意



Carefully read instruction sheet before assembling. When you use glue or paint, do not use near open flame and use in well ventilated room. Keep out of reach of small children. Children must not be allowed to suck any part, or pull vinyl bag over the head.



Před započítím stavby si pečlivě prostudujte stavební návod. Při používání barev a lepidel pracujte v době větrané místnosti. Lepidla ani barvy nepoužívejte v blízkosti otevřeného ohně. Model není určen malým dětem, mohlo by dojít k požití drobných dílů.

INSTRUCTION SIGNS * INSTR. SYMBOL * INSTRUKTION SINNBILDEN * SYMBOLES * 記号の説明

OPTIONAL
VOLBABEND
OHNOUTSAND
BROUSITOPEN HOLE
VYVRTAT OTVORSYMMETRICAL ASSEMBLY
SYMETRICKÁ MONTÁŽREMOVE
ODRŽNOUTREVERSE SIDE
OTOCITAPPLY EDUARD MASK
AND PAINT
POUŽIT EDUARD MASK
NABARVIT

PARTS



DÍLY



TEILE



PIÈCES



部品

PLASTIC PARTS

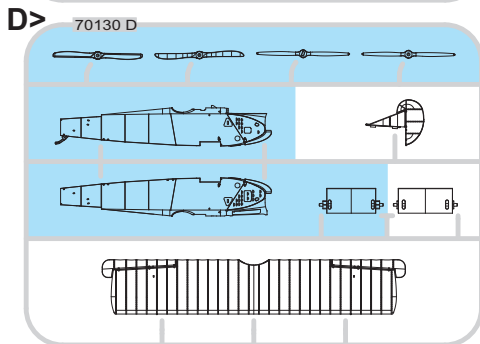
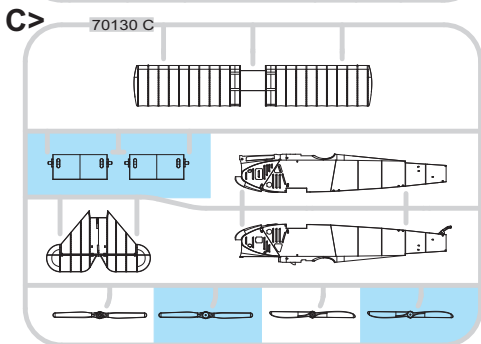
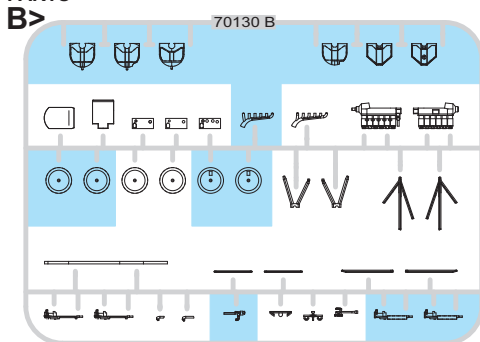
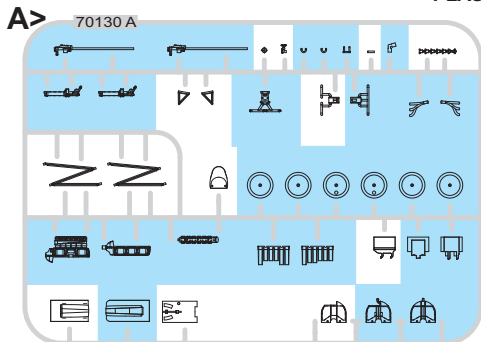

PE - PHOTO ETCHED DETAIL PARTS

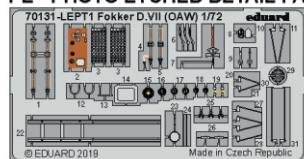
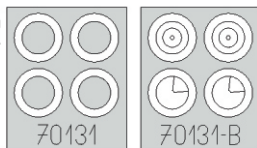
eduard
MASK

Parts not for use. -Teile werden nicht verwendet. -Pièces à ne pas utiliser. -Tyto díly nepoužívejte při stavbě. - 使用しない部品

COLOURS



BARVY



FARBEN



PEINTURE



色

GSI Colors (GUNZE)		MISSION MODELS	
AQUEOUS	Mr.COLOR	PAINTS	
L12	C2	MMP-047	BLACK
L14	C4	MMP-007	YELLOW
L15	C5	MMP-048	BLUE
L111	C62	MMP-001	FLAT WHITE
L112	C33	MMP-047	FLAT BLACK
L125	C34		SKY BLUE
L137	C43		WOOD BROWN
L139	C67		PURPLE
L143	E108		WINE RED
L147	C41	MMP-012	RED BROWN

GSI Colors (GUNZE)		MISSION MODELS	
AQUEOUS	Mr.COLOR	PAINTS	
L131	C11	MMP-063	LIGHT GULL GRAY
L170	C69	MMP-056	GRAY
L185	C45		SAIL COLOR
L130	E361	MMP-077	DARK GREEN
	E135	MMP-018	RUSSIAN GREEN
Mr.METAL COLOR		METALLICS	
	M213	MMM-006	STEEL
	M214	MMM-001	DARK IRON
	M216	MMM-003	ALUMINIUM
	M219	MMM-008	BRASS

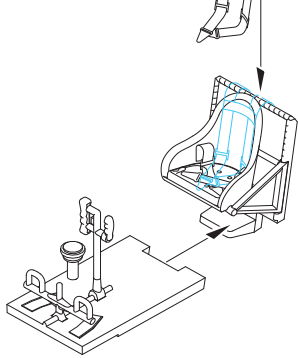
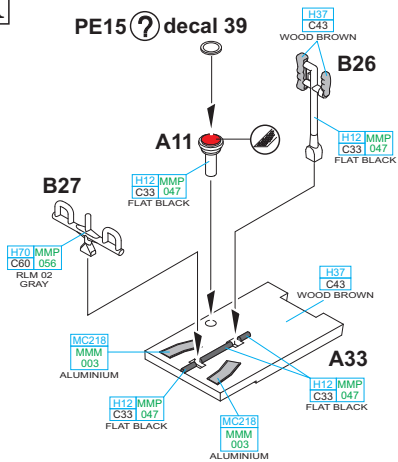
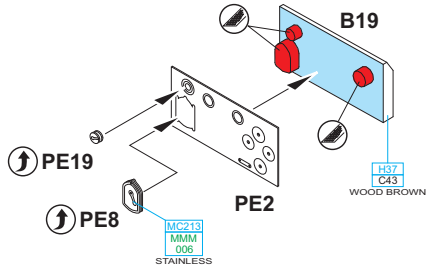
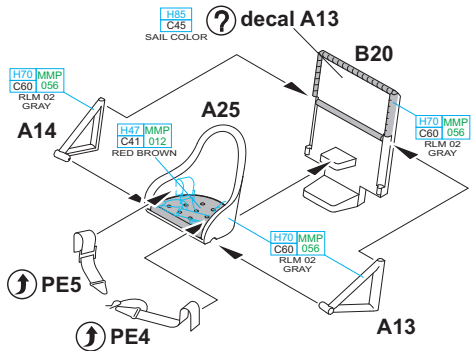
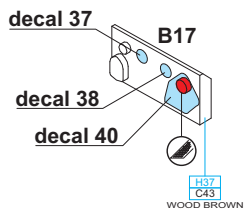
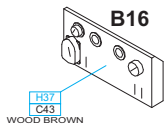
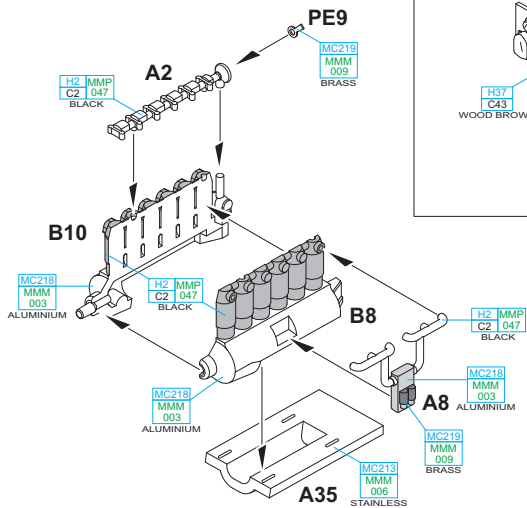
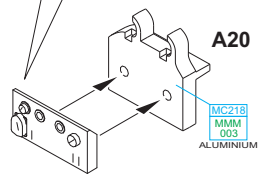
A**PE15** ? decal 39H85 C45 ? decal A13
SAIL COLOR**B****C**

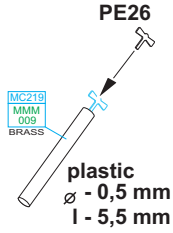
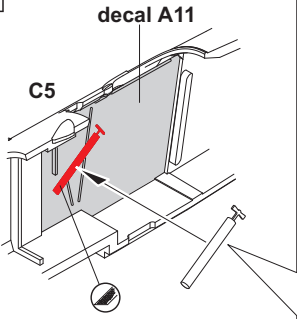
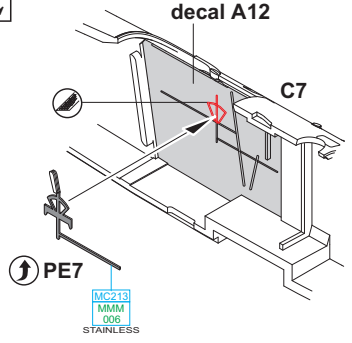
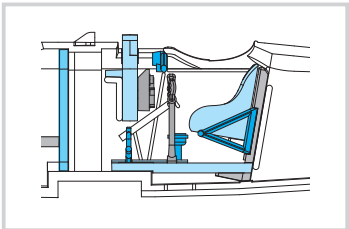
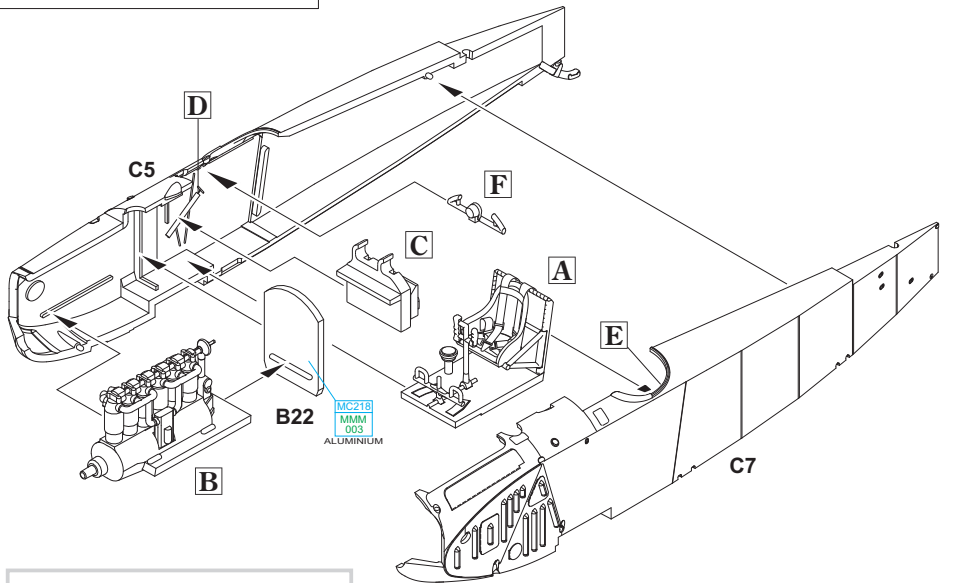
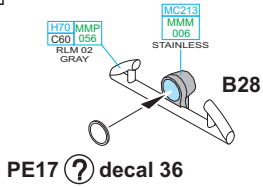
D**E****F**

PE18 ? decal 36

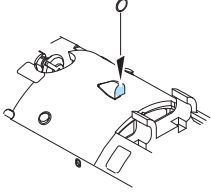

PE20
PE21

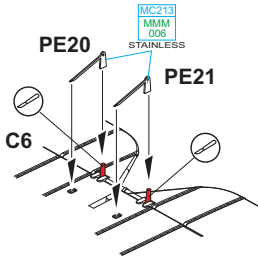

D6

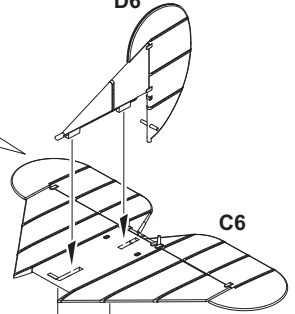

C6

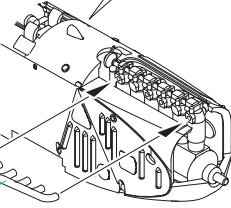

B12

MC214
MMM
001
DARK IRON

A5
MC219
MMM
009
BRASS
MC219
MMM
006
STAINLESS

A5

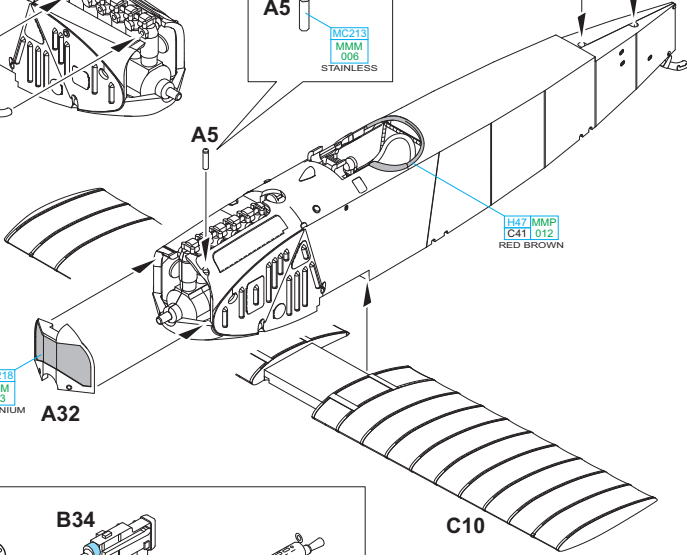

H47 MMP
C41 012
RED BROWN

MC218
MMM
003
ALUMINIUM

A32

C10

2 pcs.

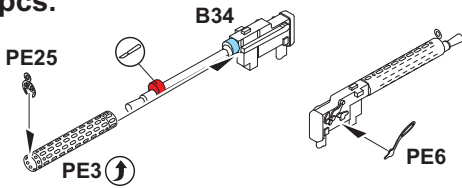

PE25

B34

PE3

PE6

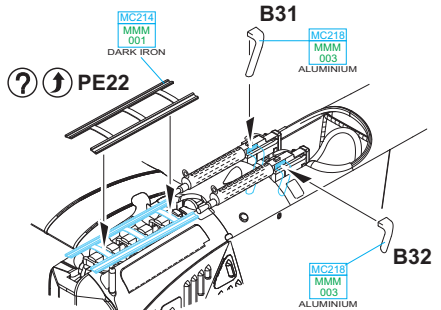

B31

MC214
MMM
001
DARK IRON

MC218
MMM
003
ALUMINIUM

PE22

B32

MC218
MMM
003
ALUMINIUM

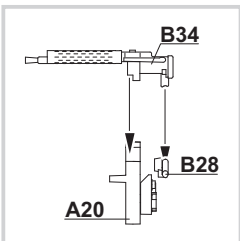

B34

B28

A20

MC214
MMM
001
DARK IRON

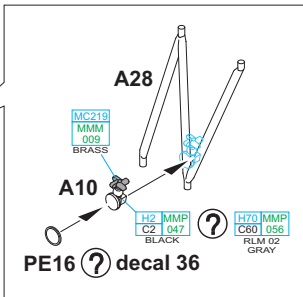
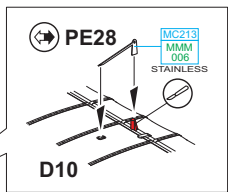
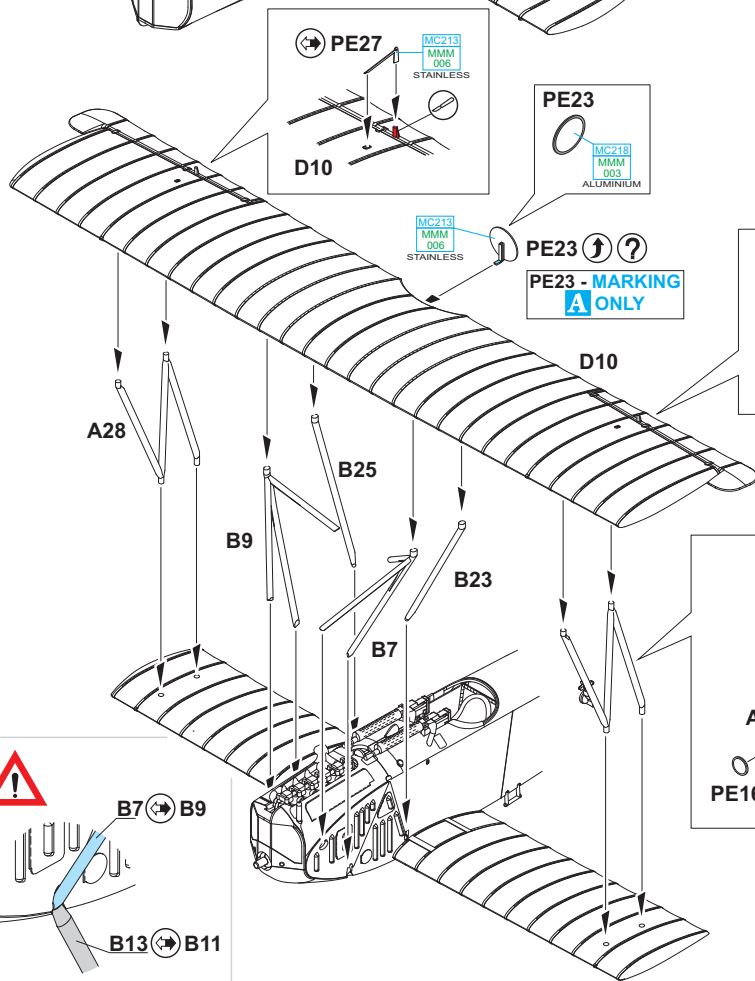
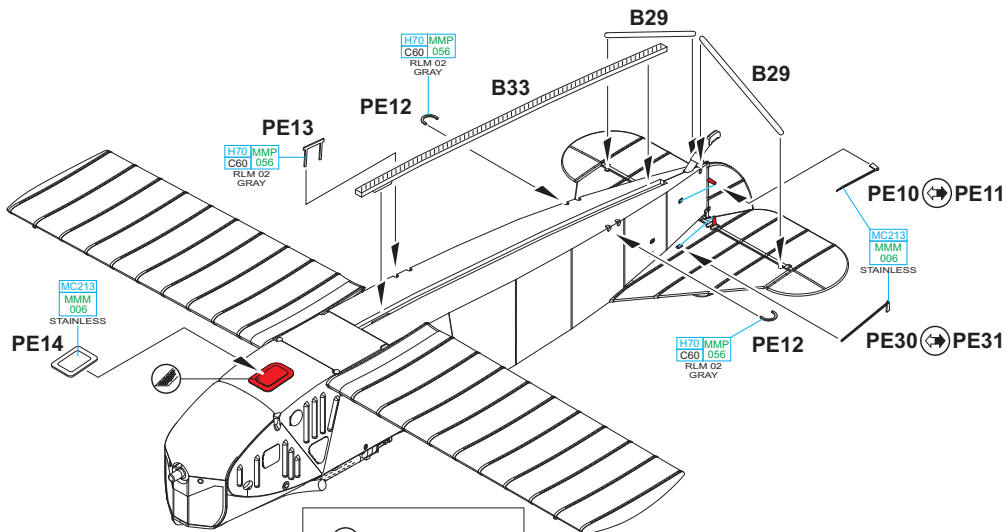

2 pcs.
B18

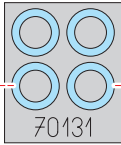

2 pcs.
B18



2 pcs.
B18

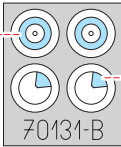

2 pcs.
B18

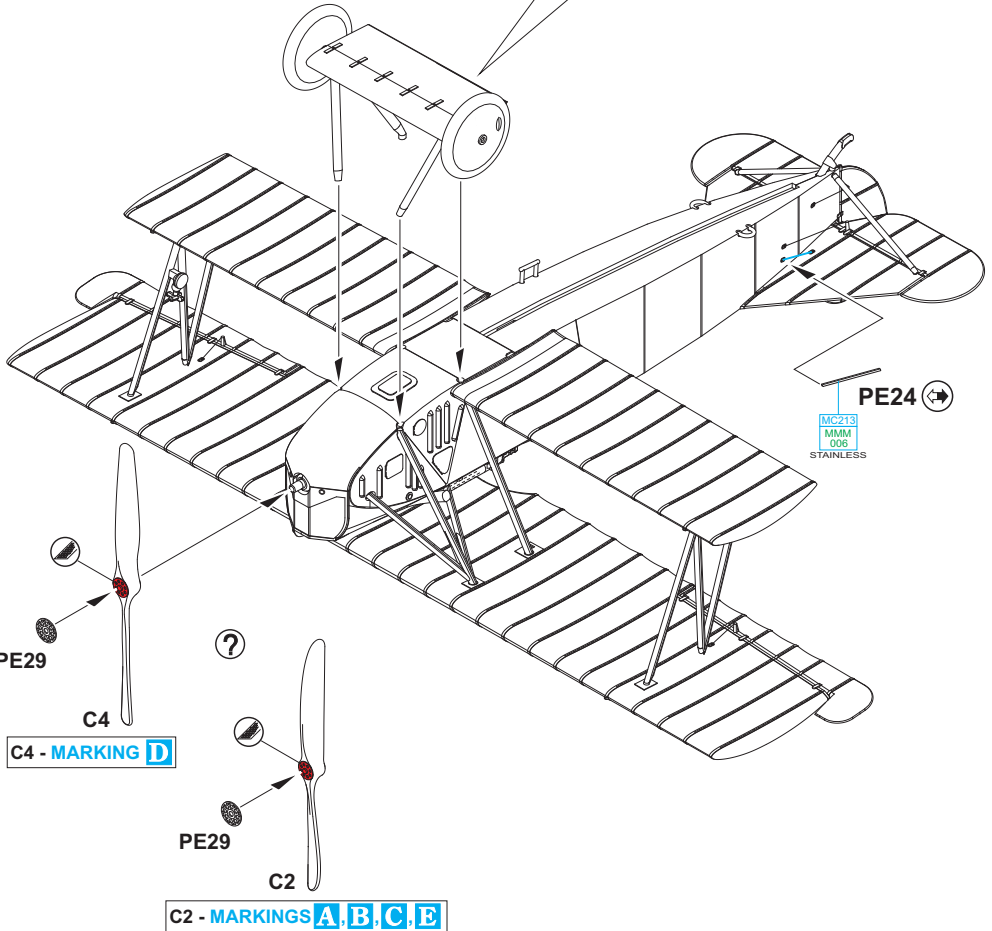
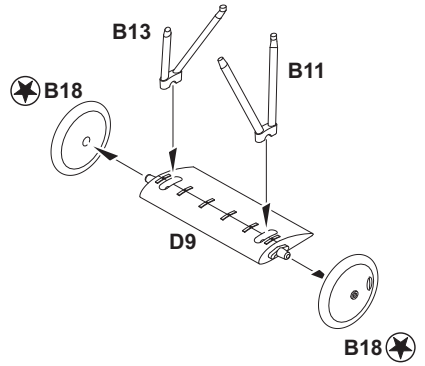

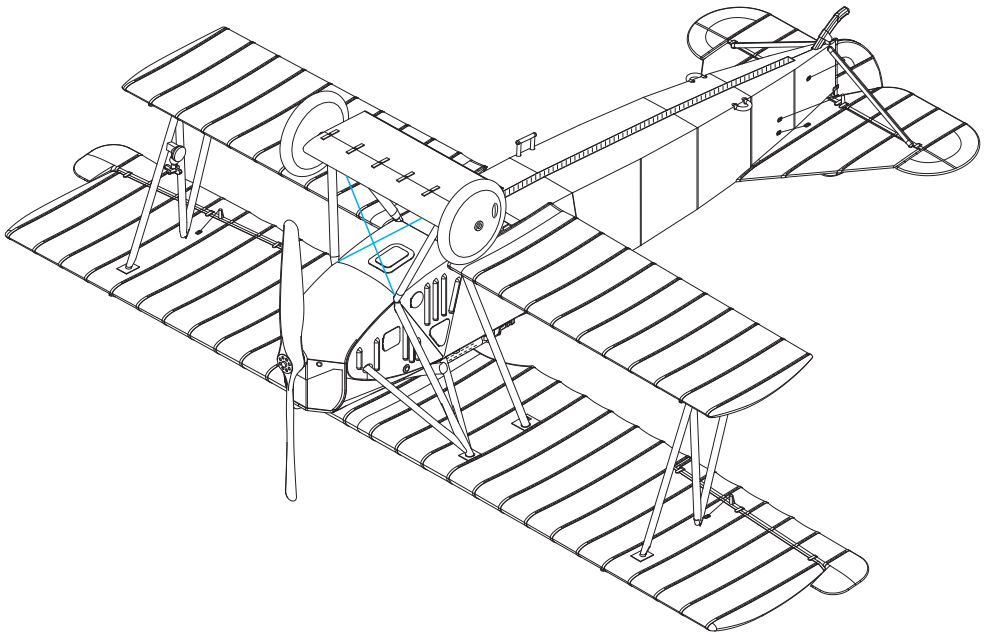
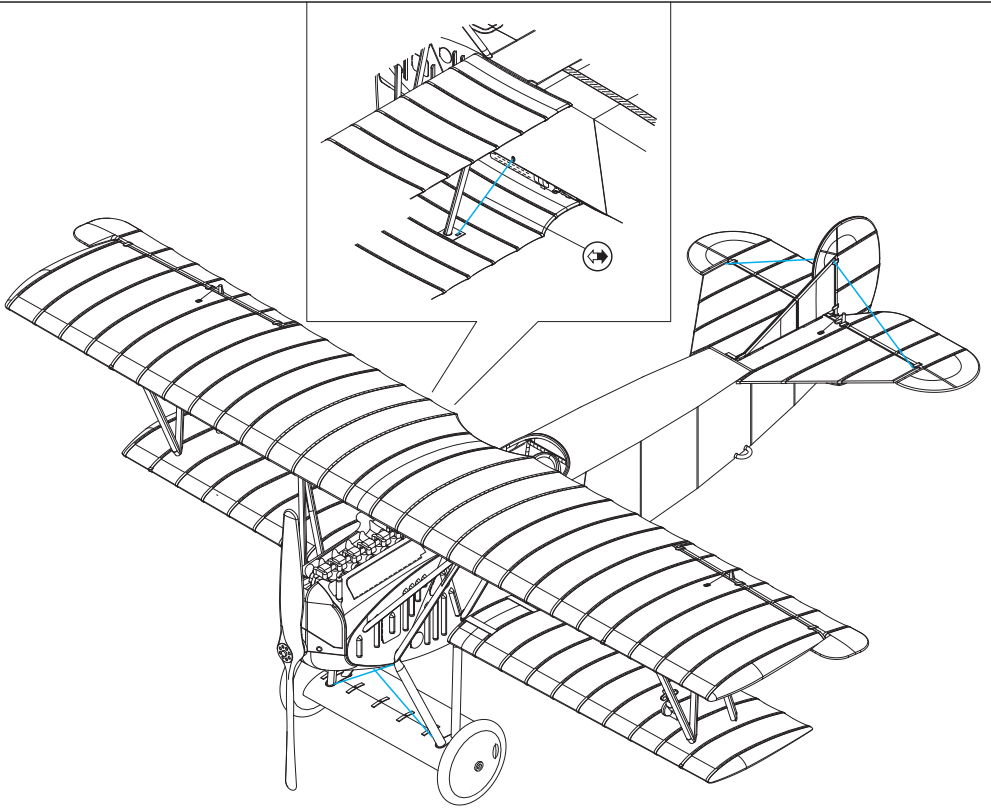

TOP

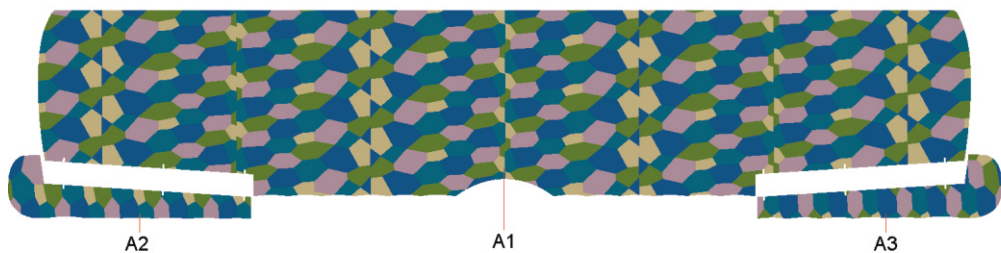

BOTTOM

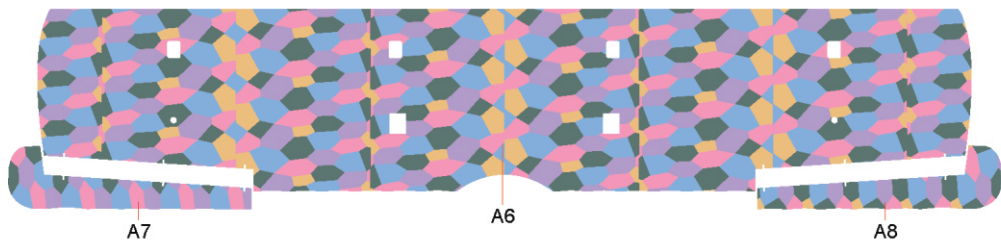

TOP

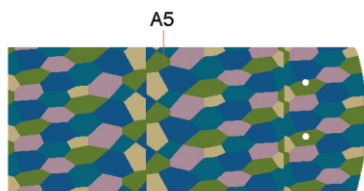
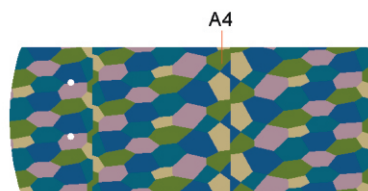

BOTTOM

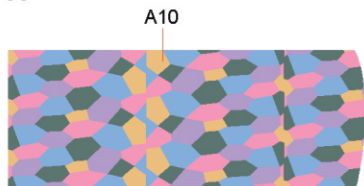
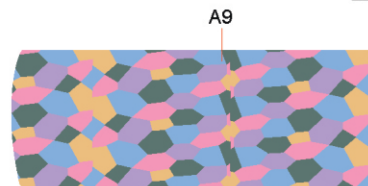

TOP

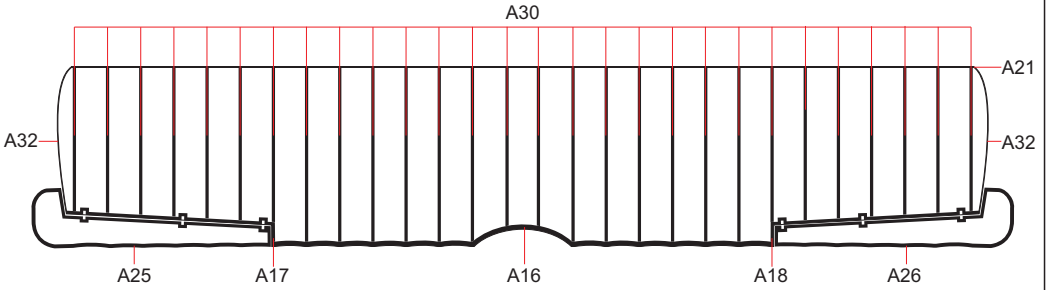

BOTTOM

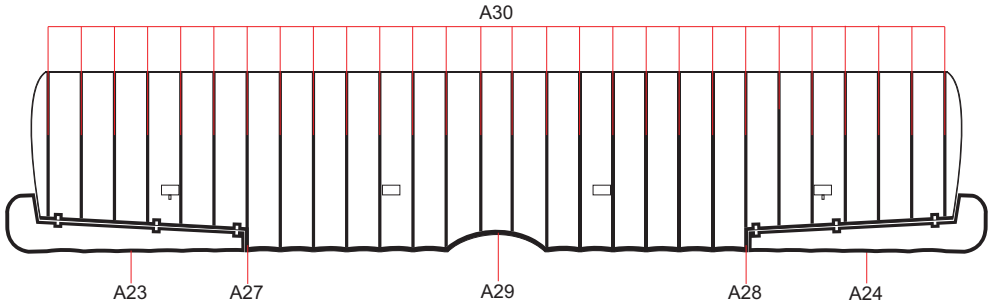

TOP

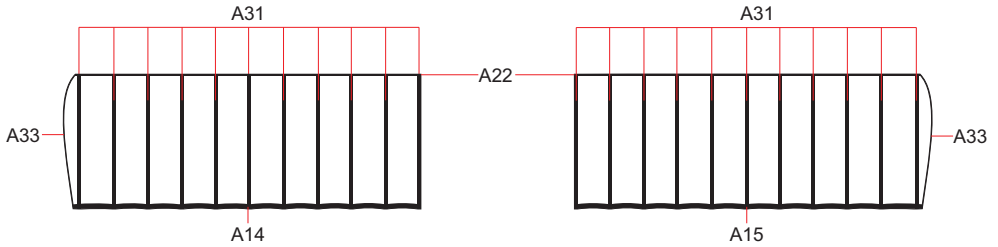

BOTTOM

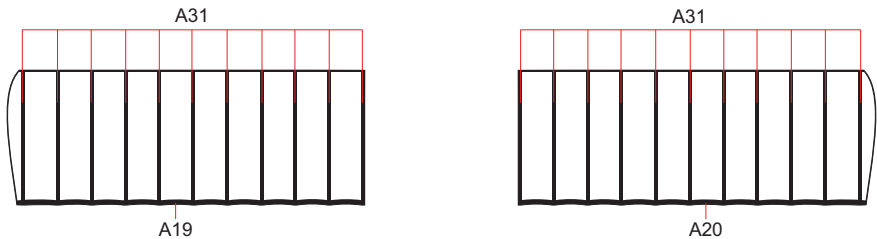

A flown by Lt. Wilhelm Leusch, CO of Jasta 19, Trier, Germany, October 1918

A native of Neuss in North Rhine-Westphalia, Leusch was born on October 15th, 1892 and joined the German Air Force in October 1914, initially flying two seat aircraft. In April 1917, he was transferred to Jasta 19 from Jasta 13, later replacing the seriously injured unit CO von Beauilleu-Marconay on October 18th, 1918. Lt. Leusch achieved a total of five kills, the last three coming during the final weeks of the war. He died on August 14th, 1921 in a gliding accident. The aircraft, produced at Ostdeutsche Albatros Werke, had the fuselage and wings covered in a five-colour Lozenge pattern. After delivery to Jasta 19, it was modified correspondingly to other aircraft of the unit, receiving a dark blue fuselage and a yellow nose. The dragon on the fuselage was the pilot's personal marking.

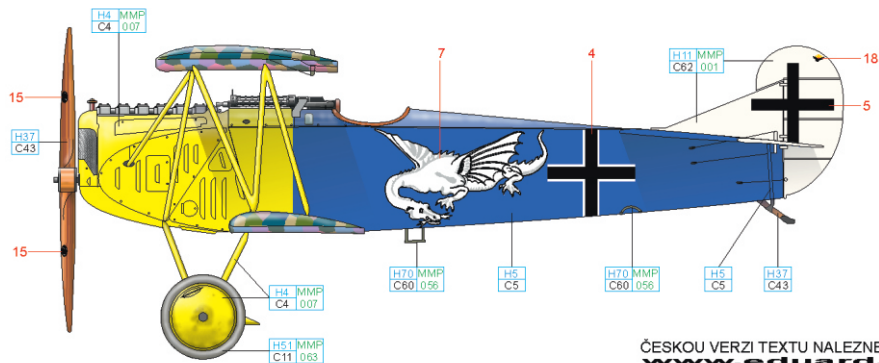

ČESKOU VERZI TEXTU NALEZNETE NA
www.eduard.cz
 POD KATALOGOVÝM ČÍSLEM 70131

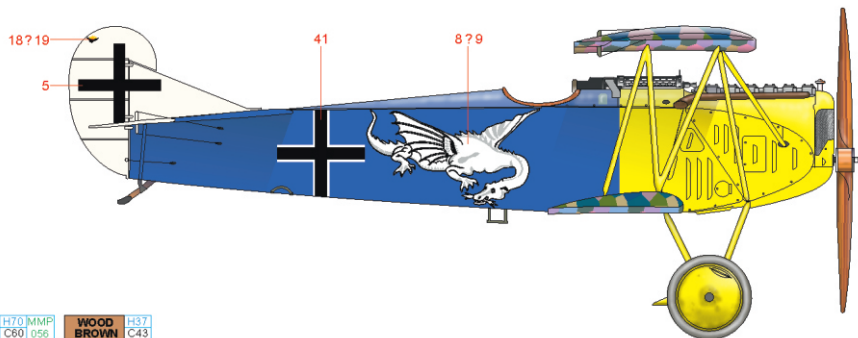
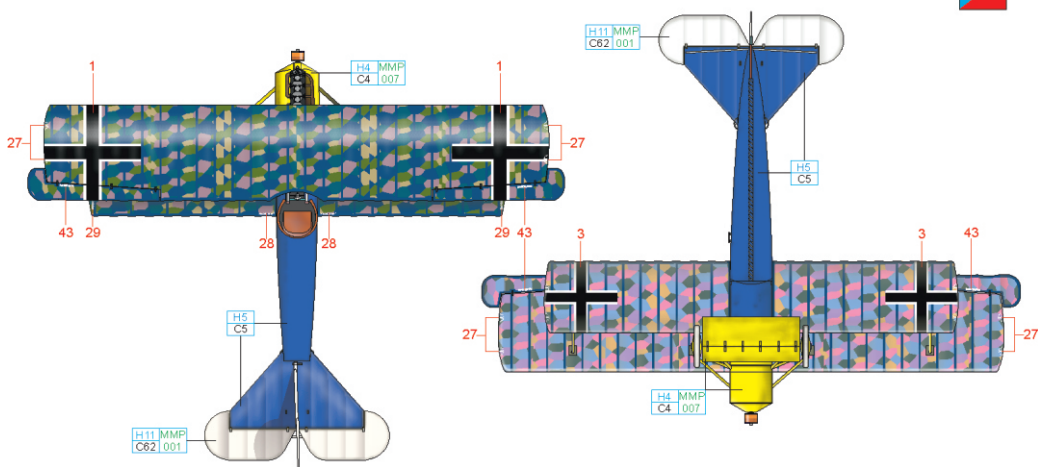

GRAY	H70 MMP C60 056	WOOD BROWN	H37 C43
BLUE	H5 C5	YELLOW	H4 MMP C4 007
WHITE	H11 MMP C62 001	GRAY	H51 MMP C11 063

C flown by Lt. Franz Büchner, CO of Jasta 13, Trier, Germany, October 1918

A native of Leipzig, Franz Büchner was born on January 2nd, 1898 and volunteered for the army at sixteen years of age. He took part in the fighting in France and in Russia. In the spring of 1916, he was transferred to the air force, where he first served with FFA 270. He didn't serve with a fighter unit until March 1917, when he was assigned to Jasta 9, and in September of the same year, to Jasta 13. There, he served out the war, and from June 15th, 1918, as the unit's commander. Over the course of the Great War, he would accumulate forty kills. He was killed on March 18th, 1920 during civil unrest in Germany, having been shot down not far from where he was born. Jasta 13 aircraft were easily identified thanks to the blue colouring of their fuselages and green noses. Franz Büchner had a werewolf against a green background painted on his Fokker D.VII. The wings were covered in a five-colour pattern.

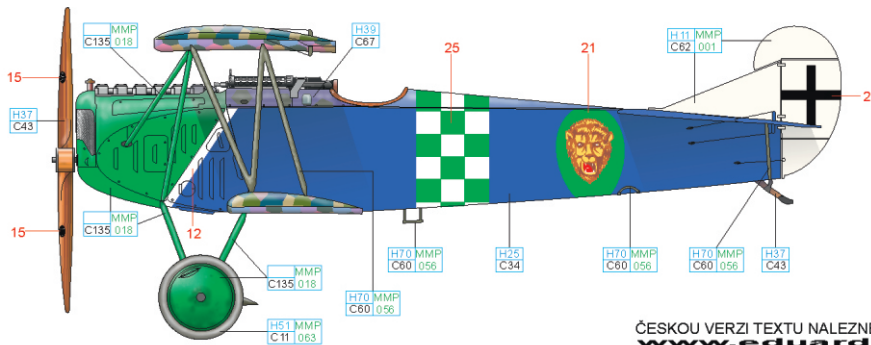

ČESKOU VERZI TEXTU NALEZNETE NA www.eduard.cz POD KATALOGOVÝM ČÍSLEM 70131

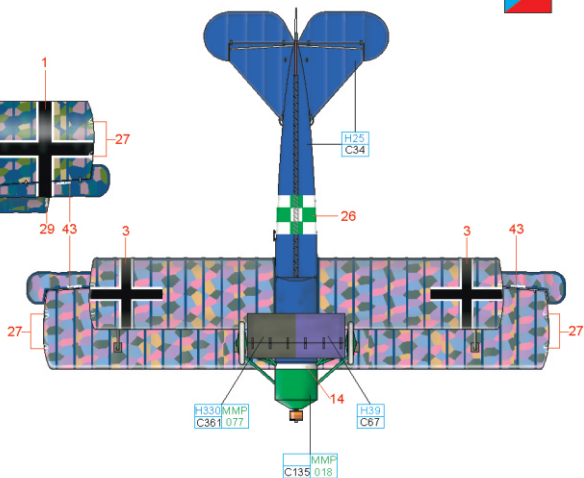
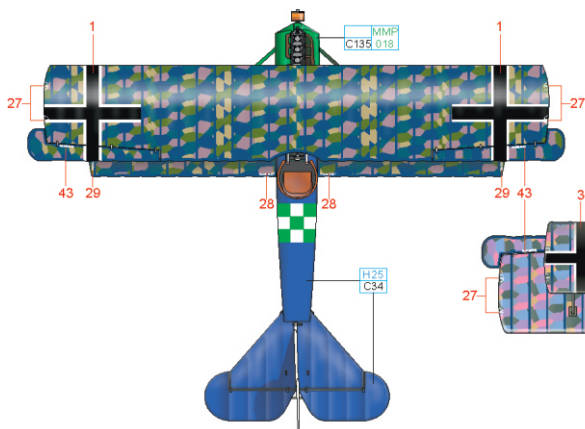

GREEN	H330 MMP C361 077	WOOD BROWN	H37 C43	PURPLE	H39 C67
GREEN	MMP C135 018	BLUE	H25 C34	WHITE	H11 MMP C62 001
		GRAY	H51 MMP C11 063	GRAY	H70 MMP C60 056

D flown by Lt. August Raben, CO of Jasta 18, Mönzingen (Montoy – Flanville now), October 1918

The colouring of Jasta 18 aircraft was modified following the designation of August Raben as its commander on March 14th, 1918. Raben previously commanded Jasta 11. Initially, the aircraft had a red nose while the remaining upper and lower surfaces were dark blue. The change involved repainting the upper and side surfaces of the front of the aircraft, including the upper surfaces of the wings, in red. The rear of the aircraft, including the tail surfaces, were white. The sides of the fuselage were adorned with a black or white bird symbolizing the commander's name, which translates to 'Raven'.

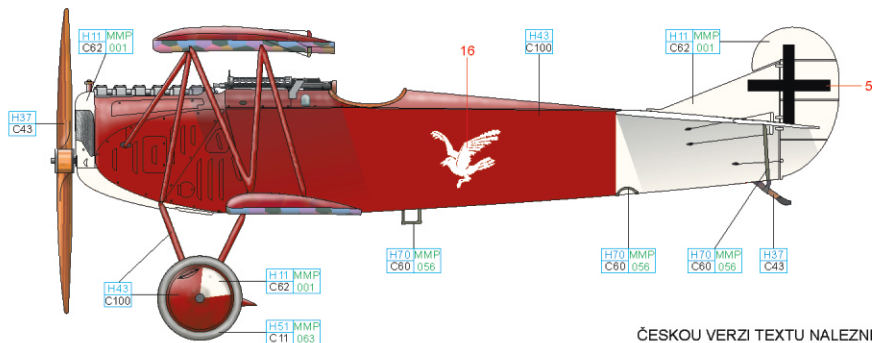

ČESKOU VERZI TEXTU NALEZNETE NA www.eduard.cz POD KATALOGOVÝM ČÍSLEM 70131

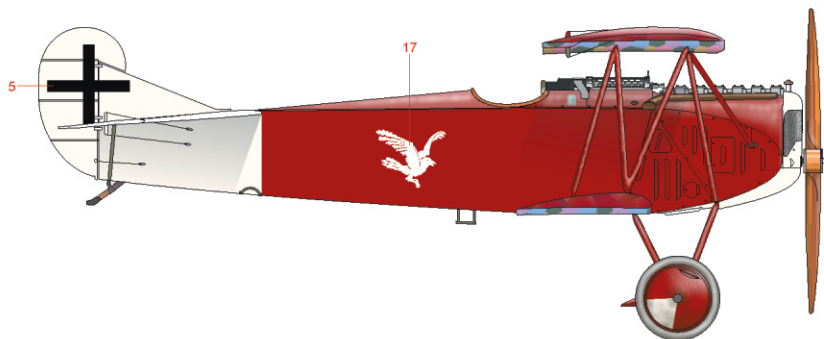
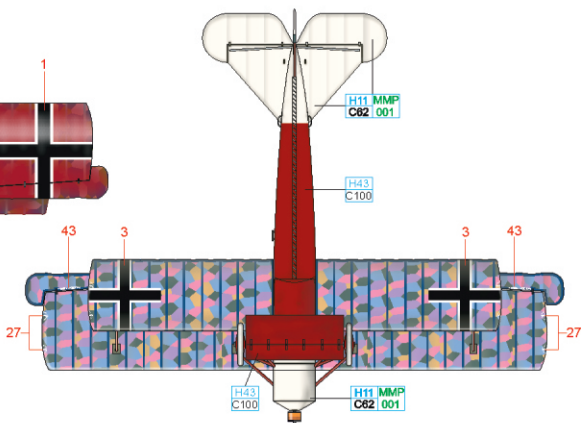
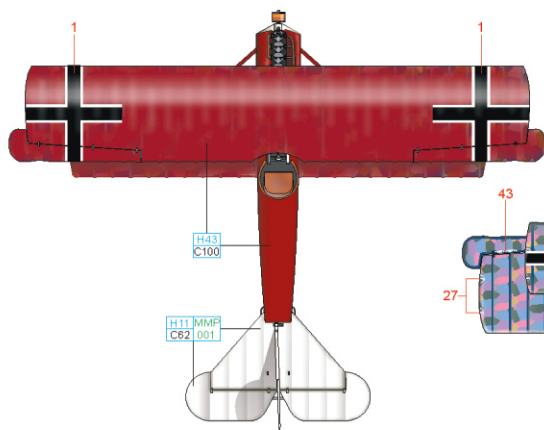

GRAY	H70 MMP C60 056	WHITE	H11 MMP C62 001	GRAY	H51 MMP C11 063	RED	H43 C100	WOOD BROWN	H37 C43
------	-----------------	-------	-----------------	------	-----------------	-----	----------	------------	---------

E flown by Lt. Alfred Greven, Jasta 12, Carignan, France, October 1918

A native of Elbfeld (today a part of Wuppertal city), Alfred Greven was born in 1897, and after completing high school, he volunteered for the army in September 1914. After recovering from wounds, he was transferred to the air force, and as the Great War drew to its conclusion, he was assigned to Jasta 12. With this unit over the last two months of the conflict, he earned four kills. In 1920 he began work in the film industry, and in 1931, he joined the Nazi Party. In 1940, he was named head of the newly established company 'Continental Film'. He continued to work in the film industry after the end of the Second World War and produced 59 films. He died on February 9th, 1973 in Cologne. The fuselage of Greven's aircraft was painted consistently with other aircraft of Jasta 12, blue with a white nose. The fuselage carried a stylized white lightning flash, an item that also adorned Greven's Siemens Schuckert D.III in the summer of 1918.

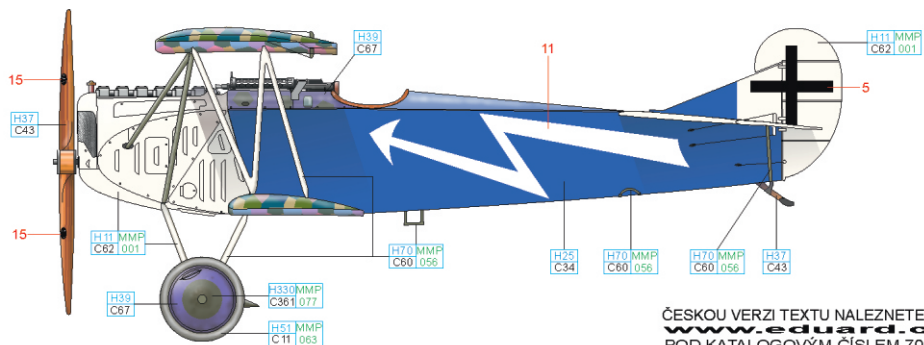

ČESKOU VERZI TEXTU NALEZNETE NA
www.eduard.cz
 POD KATALOGOVÝM ČÍSLEM 70131

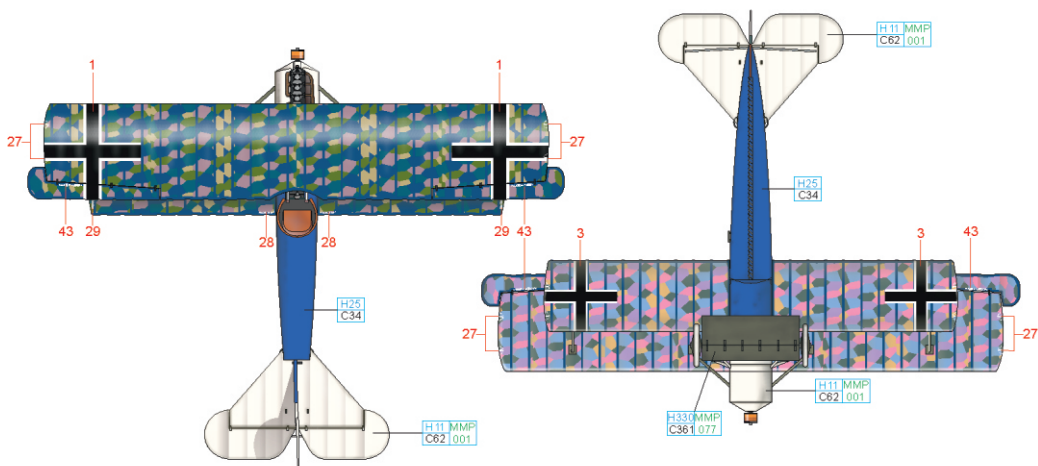

PURPLE	H39 C67	GREEN	H330 MMP C361 077
BLUE	H25 C34	WHITE	H11 MMP C62 001
		GRAY	H51 MMP C11 063
		GRAY	H70 MMP C60 056
		WOOD BROWN	H37 C43

LEGIE

1/72

eduard
LIMITED EDITION

SPAD XIII čs. pilotů

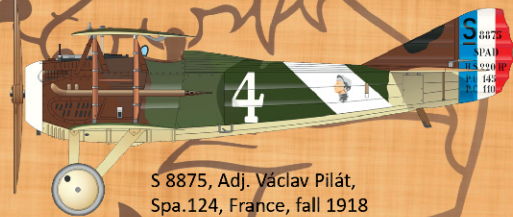

S 8875, Adj. Václav Pilát,
Spa.124, France, fall 1918



S 2807, by Adj. Augustin Charvát,
Spa.315, Chaux, France, September 1918

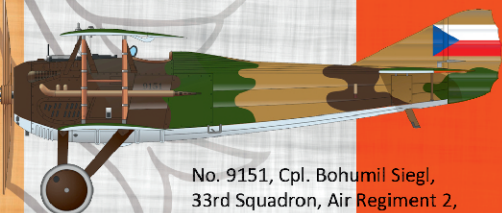

No. 9151, Cpl. Bohumil Siegl,
33rd Squadron, Air Regiment 2,
Lípa Airfield near Německý Brod,
Czechoslovakia, September 1st, 1924



No. 9152, Sgt. František Lehký,
32nd Squadron, Air Regiment 1,
Blíževdly Airfield, Czechoslovakia,
August 28th, 1924