

Aero | VODOCHODY

L-29 DELFIN



1/72

UNASSEMBLED MODEL KIT

INSTRUCTIONS



THE AERO L-29 DELFIN

“海豚”教練機

L-29 海豚 [捷克語: Delfin, 北約代號: Maya (瑪雅)] 是一款捷克軍用噴射教練機, 20世紀60年代華沙公約國成員國的標準教練機。L-29海豚也是捷克第一次自行設計並生產的噴射機。

在20世紀50年代末, 蘇聯空軍尋找一款噴射教練機以取代當時的活塞引擎教練機。這一需求不久便擴大到了其它東方集團中的空軍。於是, 沃多喬迪航空推出了名為「XL-29」的原型機, 第一架採用英國西德利公司的蝸蛇引擎, 於1959年4月5日首飛; 第二架則換裝了捷克制M-701引擎, 隨後該型號的飛機都採用了這一引擎。

L-29海豚的基本設計概念是簡約、易於生產和易於操控。其簡單和耐用的特性體現於全手動飛行操控、大的襟翼和機身兩側使飛機平滑、穩定地航行的穿孔氣閘, 這些特性使它獲得了良好的安全飛行記錄。L-29海豚能夠從草地、沙地或無道面的機場跑道上起降。教練及學生的座椅都是彈射椅, 採用串列式布置, 後方的教練座椅略高於學員座椅。

1961年, L-29海豚與TS-11火星、雅克-30進行評估, L-29海豚最後脫穎而出。除了波蘭選擇了繼續開發本國研制的TS-11火星外, 所有其他華約成員國都在經濟互助委員會的協議下採用了L-29海豚。

L-29海豚於1963年4月投入生產, 持續11年, 共產出3,500架。

L-29海豚用來進行基本、中級和帶武器的訓練。在進行武器訓練時, 可在飛機的硬點(外掛點)上掛載機槍、炸彈或火箭。在曠野日戰爭中, 埃及空軍曾派遣多架武裝L-29海豚攻擊以色列坦克。蘇聯空軍取得了2000多架L-29, 並獲得了北約代號「Maya」(瑪雅)。

The Aero L-29 Delfin (English: Dolphin, NATO reporting name: Maya) is a military jet trainer aircraft that became the standard jet trainer for the air forces of Warsaw Pact nations in the 1960s. It was Czechoslovakia's first locally designed and built jet aircraft.

In the late 1950s, the Soviet Air Force was seeking a jet-powered replacement for its fleet of piston-engined trainers, and this requirement was soon broadened to finding a trainer aircraft that could be adopted in common by Eastern Bloc air forces. Aero's response, the prototype XL-29 designed by Z. Rubčić and K. Tomáš first flew on 5 April 1959, powered by a British Bristol Siddeley Viper engine. The second prototype was powered by the Czech-designed M701 engine, which was used in all subsequent aircraft.

The basic design concept was to produce a straightforward, easy-to-build and operate aircraft. Simplicity and ruggedness were stressed with manual flight controls, large flaps and the incorporation of perforated airbrakes on the fuselage sides providing stable and docile flight characteristics, leading to an enviable safety record for the type. The sturdy L-29 was able to operate from grass, sand or unprepared fields. Both student pilot and instructor had ejection seats, and were positioned in tandem, under separate canopies with a slightly raised instructor position.

In 1961, the L-29 was evaluated against the PZL TS-11 Iskra and Yakovlev Yak-30 and emerged the winner. Poland chose to pursue the development of the TS-11 Iskra anyway, but all other Warsaw Pact countries adopted the Delfin under the agreements of COMECON.

Production began April 1963 and continued for 11 years, with 3,600 eventually built until 1974.

The Delfin served in basic, intermediate and weapons training roles. For this latter mission, they were equipped with hardpoints to carry gunpods, bombs or rockets, and thus armed, Egyptian L-29s were sent into combat against Israeli tanks during the Yom Kippur War. More than 2,000 L-29s were supplied to the Soviet Air Force, acquiring the NATO reporting name "Maya".



- 產品不適合8歲以下的兒童。
- 產品中含有帶尖點的小零件。
- 對於3歲以下兒童當心因窒息產生的危害。

**NOT SUITABLE FOR CHILDREN UNDER 8 YEARS.
CONTAINS FUNCTIONAL SHARP POINTS CONTAINS
SMALL PARTS. BEWARE OF CHOKING HAZARD OF
CHILDREN UNDER 3 YEARS.**

PAINT AND COLOR USE

1 白色
White

3 紅色
Red

4 黃色
Yellow

8 銀色
Silver

12 橄欖色
Olive Drab

28 鋼鐵色
Steel

33 啞黑色
Flat Black

34 淺藍色
Light Blue

44 沙漠黃色
Sand

47 透明紅
Clear Red

50 透明藍
Clear Blue

61 燒鐵色
Burnt Iron

73 飛機灰色
Aircraft Grey

118 淺藍色-Light Blue
(RLM 78)

137 車胎黑
Tire Black

302 綠色 - Green
(FS 34092)

304 橄欖色-Olive Drab
(FS 34087)

310 棕色色 - Brown
(FS 30219)

317 灰色 - Grey
(FS 36231)

332 灰色 - Grey
(BS 627)

FS 30117

1 Ejection Seats

彈射座椅

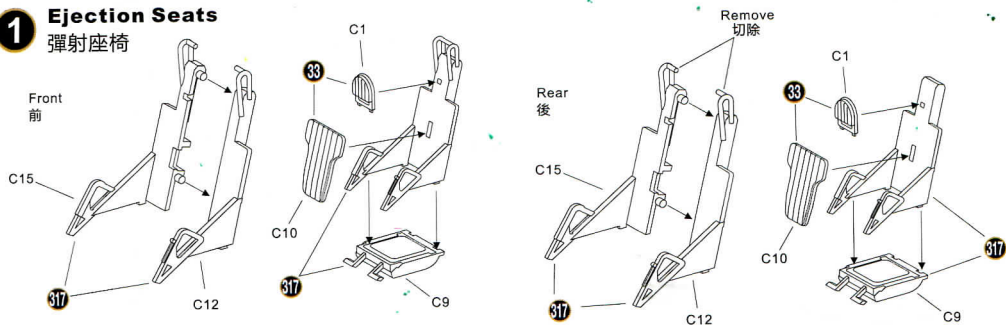

2 Cockpit

座艙

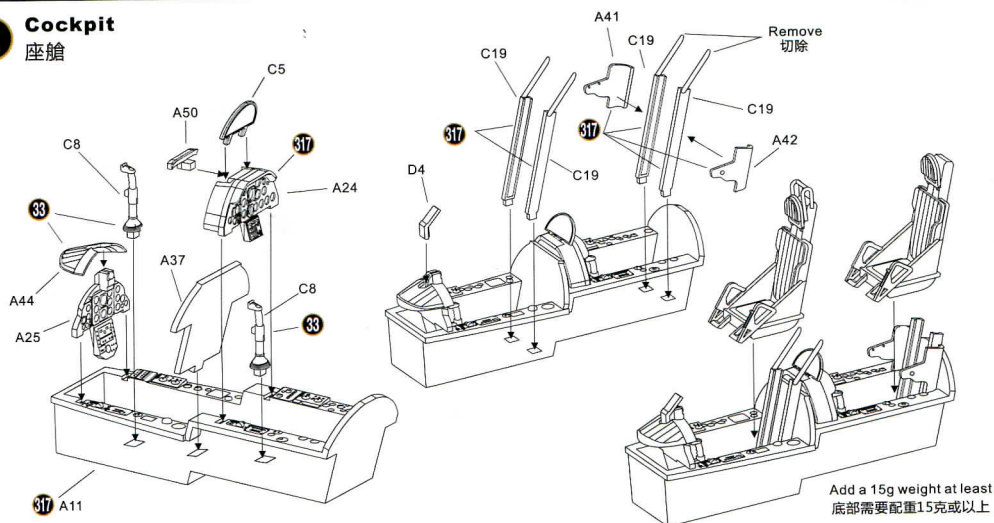

3 Placement of Instrument Decals

儀表面板水貼紙位置

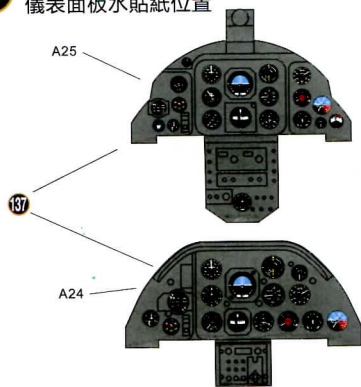

4 Nose Landing Gear Bay and Nozzle

前起落架艙及噴嘴

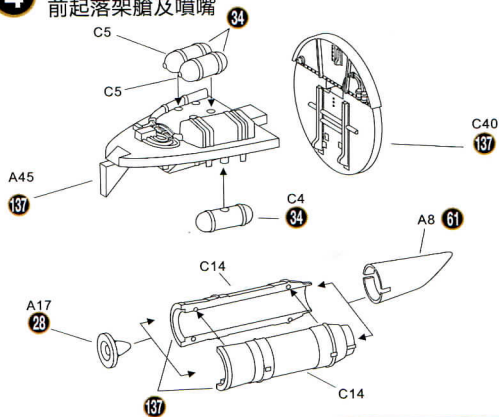

5 Closure of Fuselage

主機身組裝

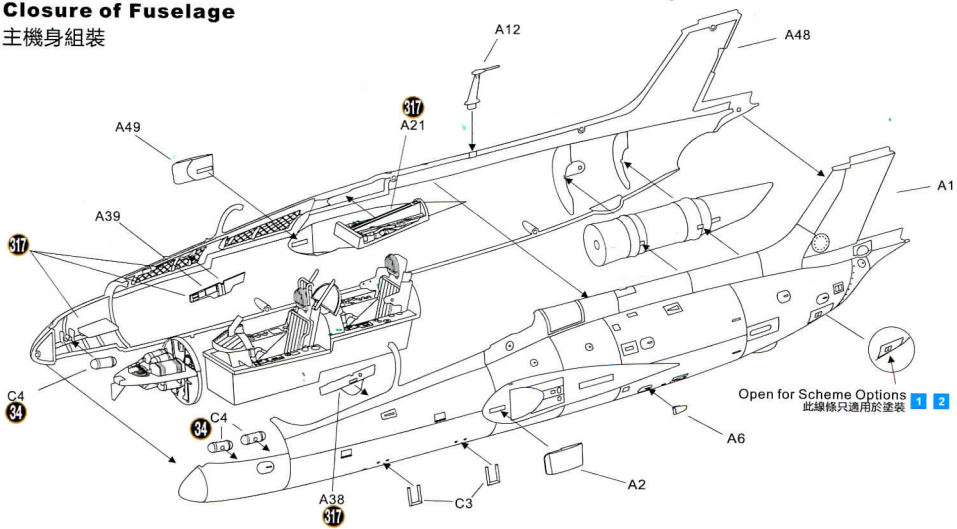

6 Wing Assembly

主機翼組裝

Landing Gear Bay Colour 起落架艙顏色 317

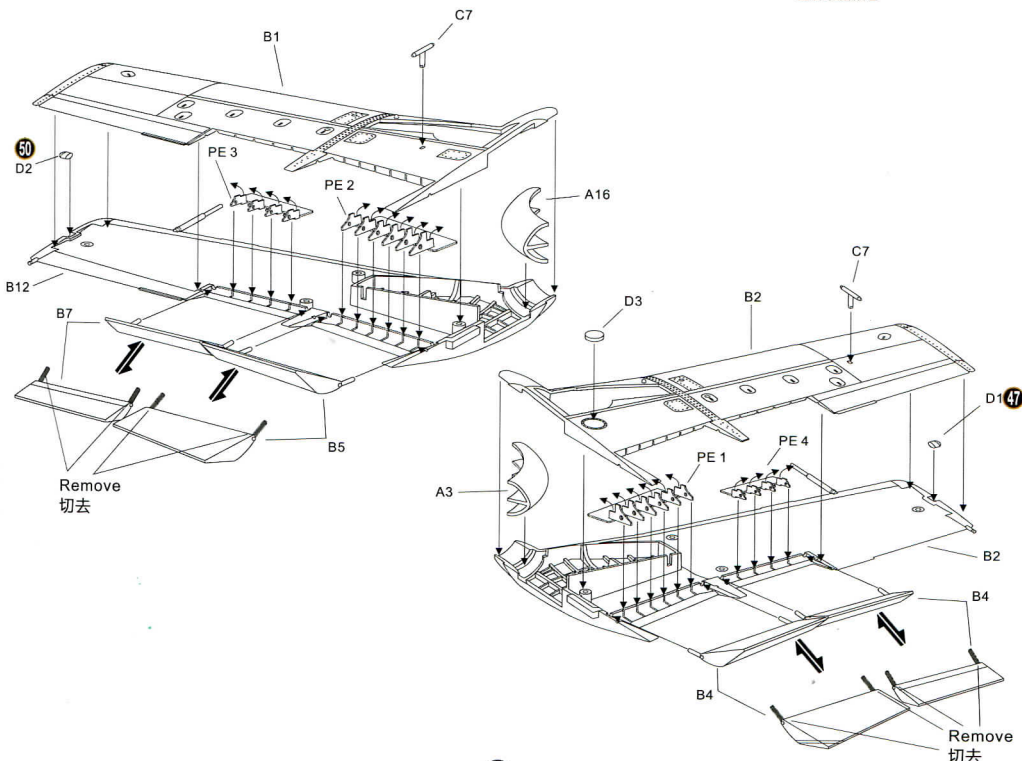

7 Attaching Wings to Fuselage 組裝機身與機翼

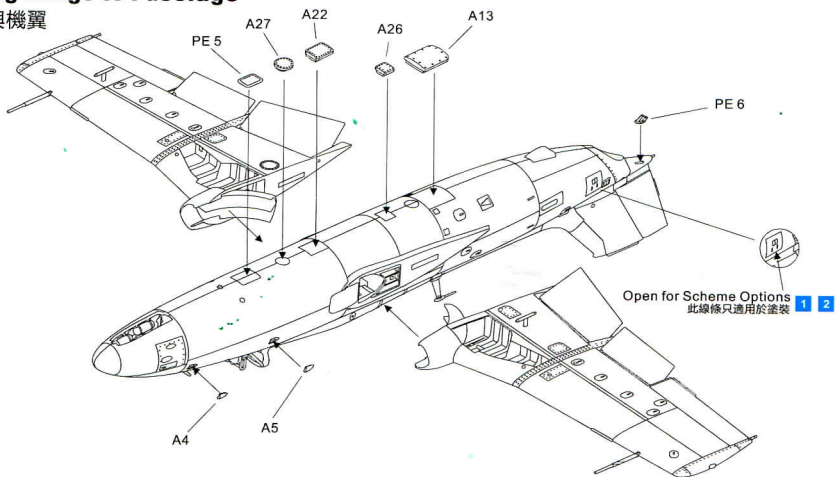

8 Tail and Rudder 垂直尾翼

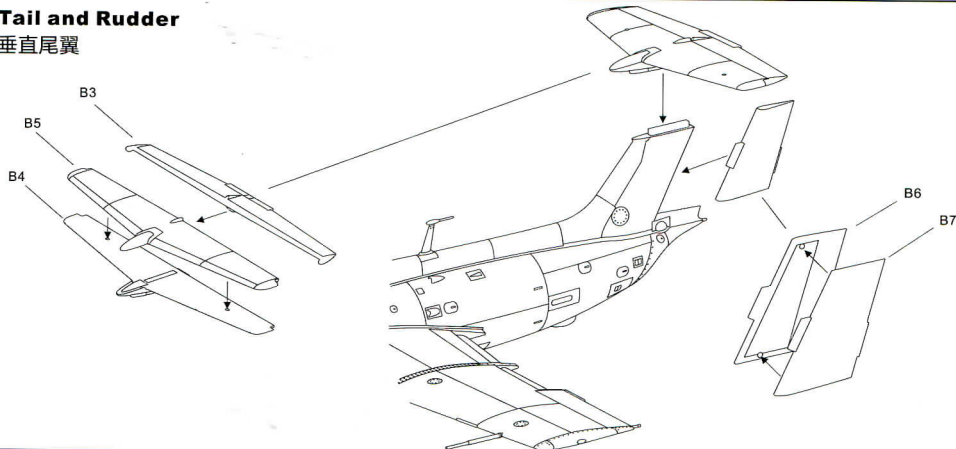

9 Landing Gear 起落架組裝

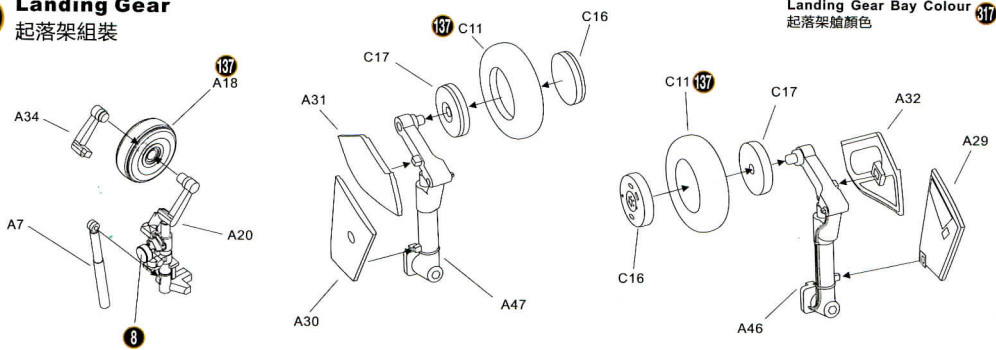

10 Attaching Landing Gear Doors

主機身組裝

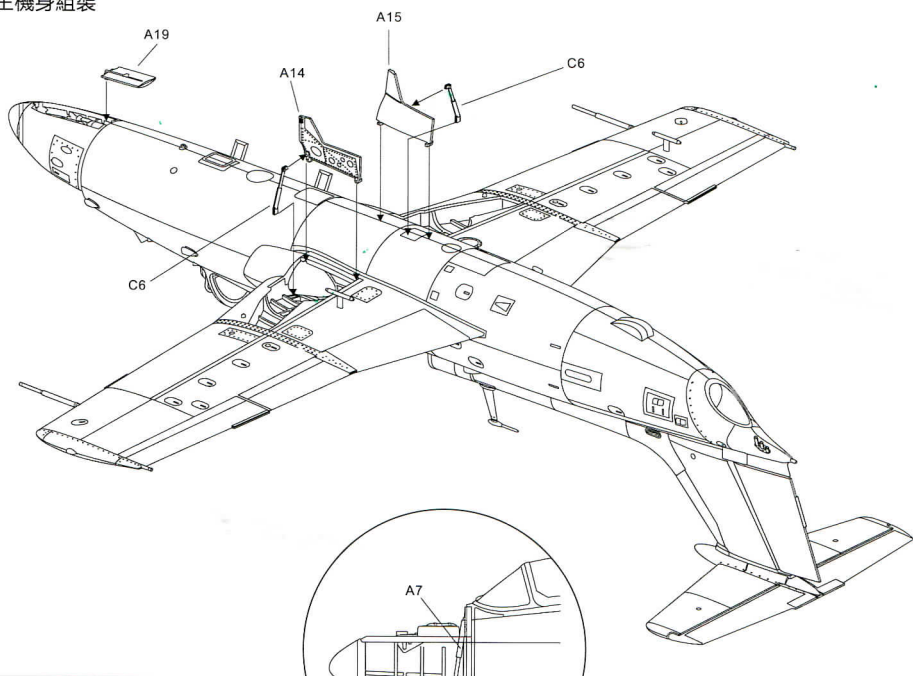

11 Attaching Landing Gear

起落架組裝

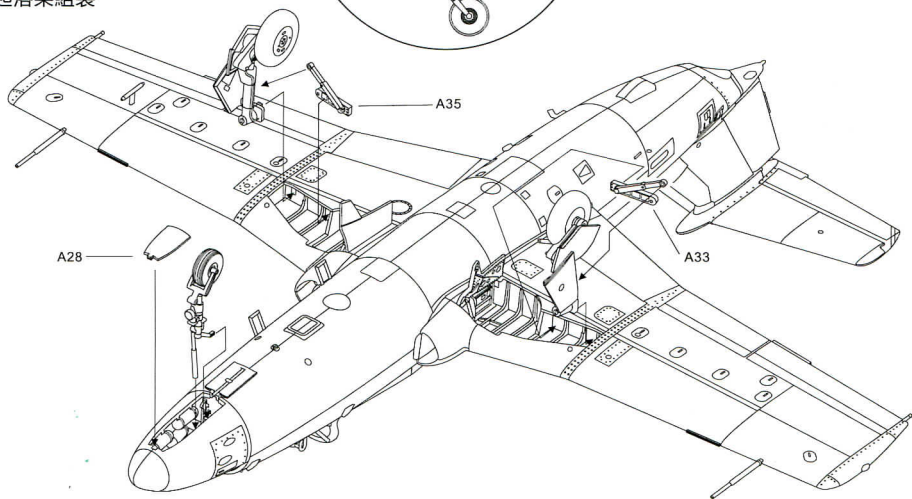

12 Air Brakes
空氣制動器

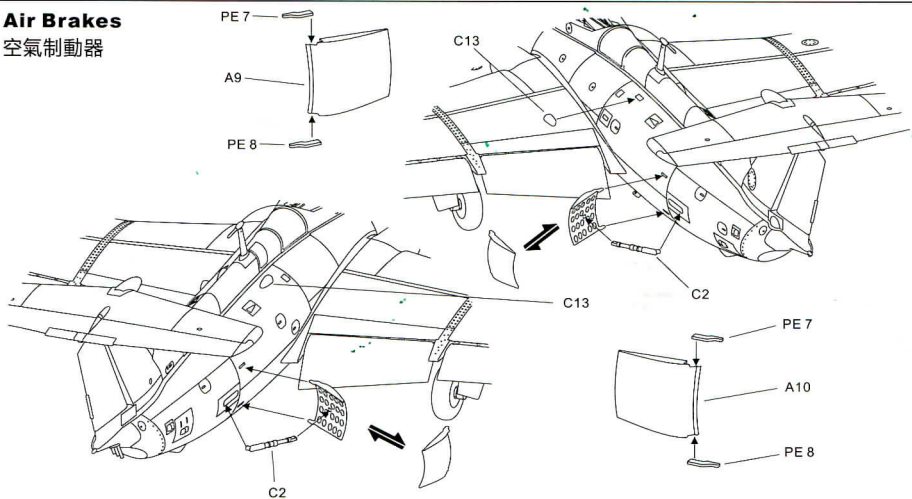

13 Attaching External Fuel Tanks
外部燃料裝配

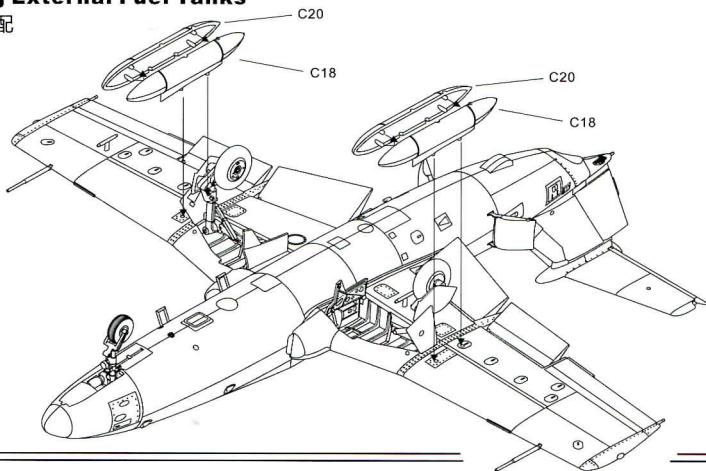

14 Nose Bay Cover
機鼻艙蓋

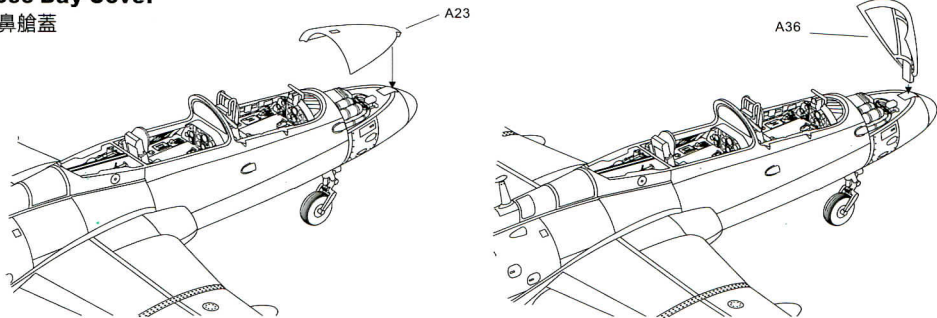

15 Attaching Canopies

駕駛艙蓋組裝

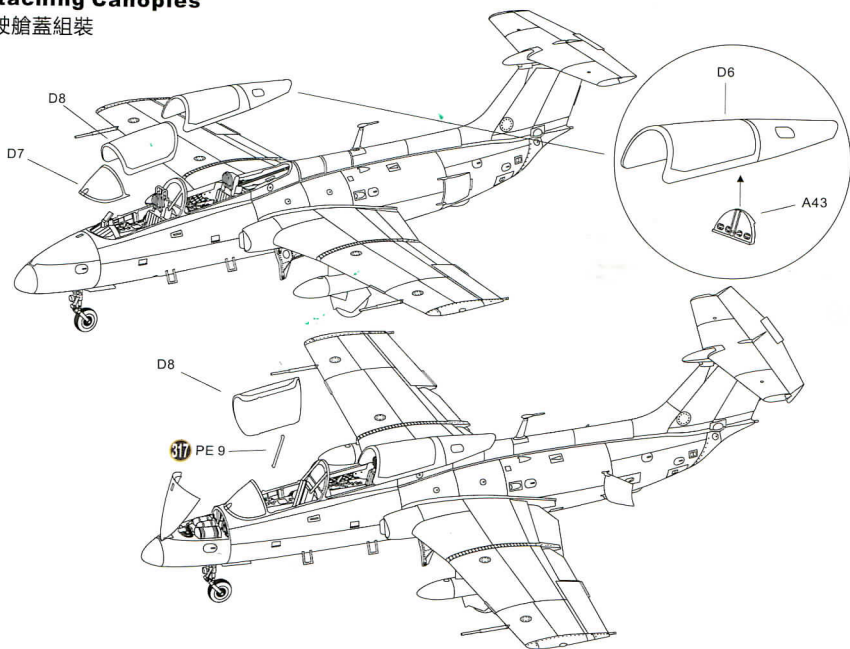

1 Ukraine - Aeroclub of Kharkiv, 2010

- Light Silver
60% FS 37875 + 40% FS 17178
- Metallic Light Blue
90% FS 15180 + 10% FS 17178
- Metallic Dark Blue
90% FS 15058 + 10% FS 17178

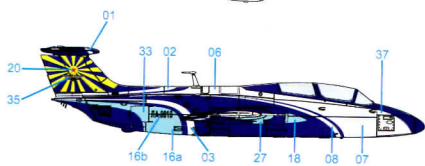
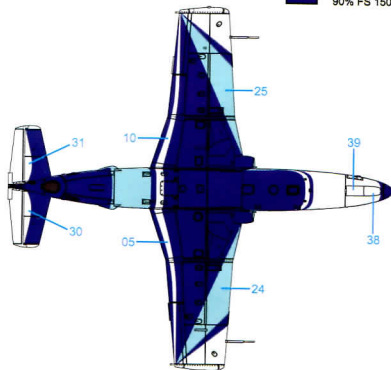
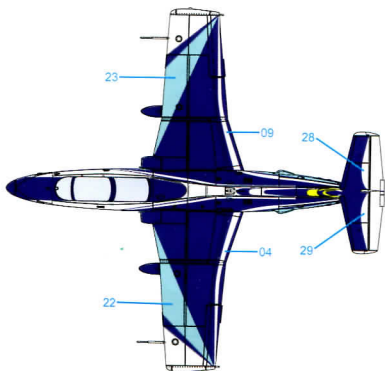
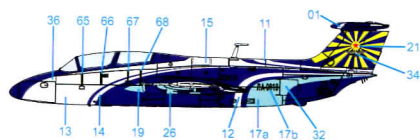

Colour callouts are approximate.
You should adjust your paints to match the decals.

2 Air Force of the USSR

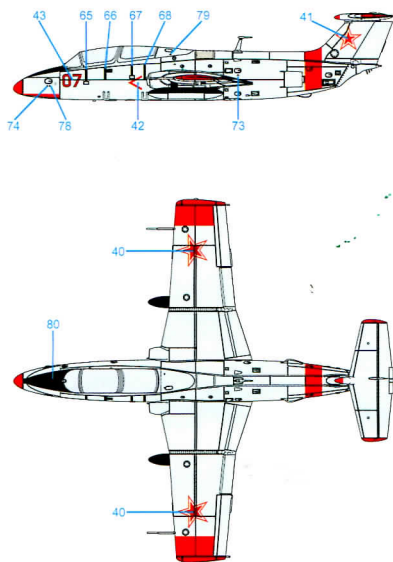

	Silver	FS 17 178
	Red	FS 21 400
	Grey	FS 26 231
	Black	FS 37 038

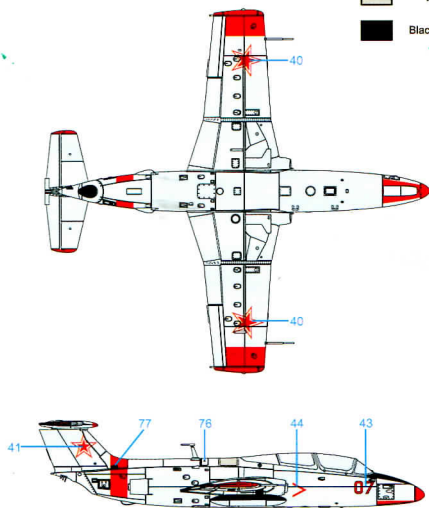

3a Czechoslovak Air Force - Kuchyňa A.B. - 1978

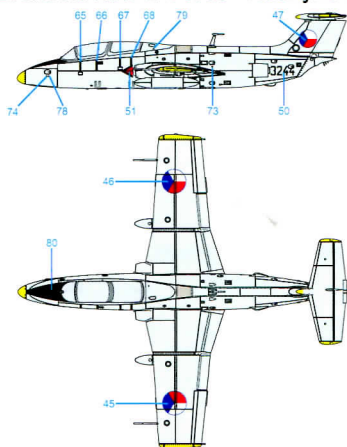

	Red	FS 21 400
	Grey	FS 26 231
	Black	FS 37 038
	Silver	FS 17 178
	Yellow	FS 33 538

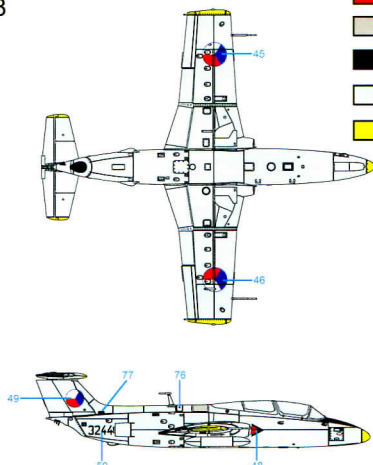

3b The same aircraft, Czechoslovak A.F. 1st half of 70's

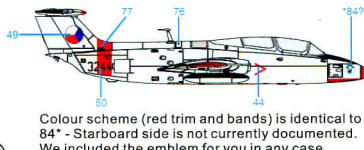
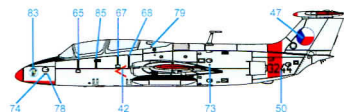

Colour scheme (red trim and bands) is identical to USSR scheme 2 above. 84* - Starboard side is not currently documented. We included the emblem for you in any case.

4 Egyptian Air Force College Bilbeis

- Sand FS 23 722
- Chocolate FS 30 045
- Green FS 34 151
- Red FS 31 136
- Grey FS 36 231

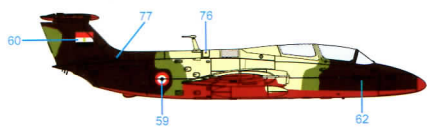
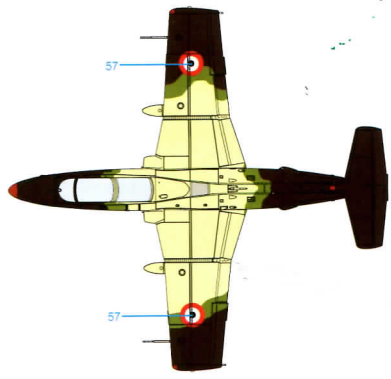
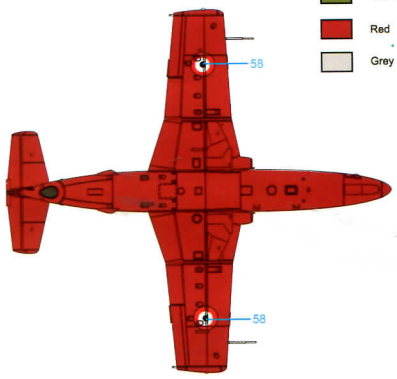
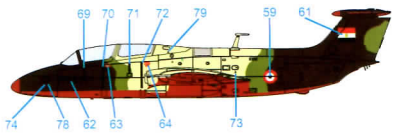

5 East German Air Force - 2nd half of 80's

- Light Blue FS 35 414
- Dark Green FS 34 092
- Brown FS 30 117
- Black FS 37 038
- Yellow FS 33 538

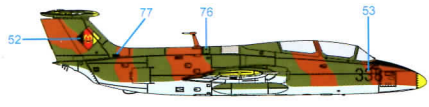
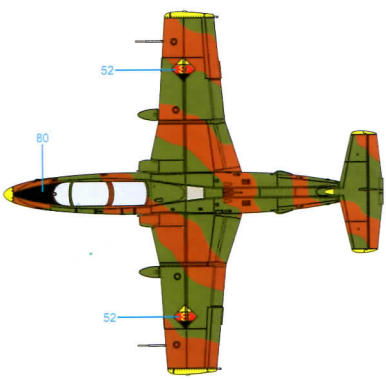
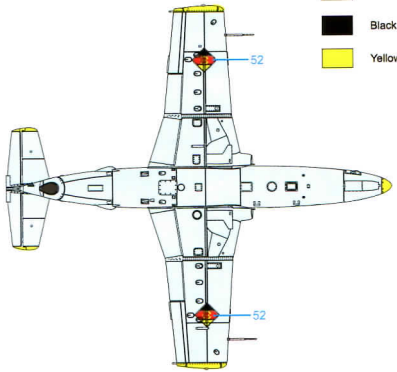
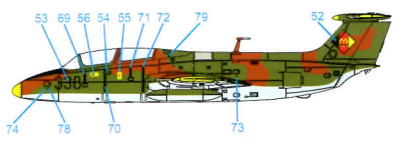

PARTS

A PARTS X 1
86B001-01

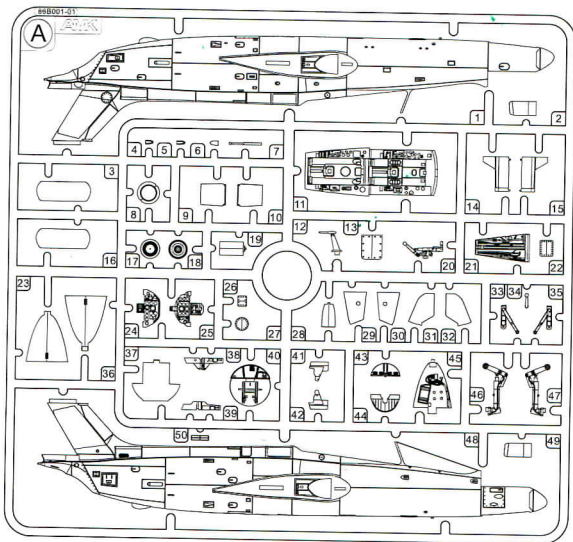

C PARTS X 2
86B001-03

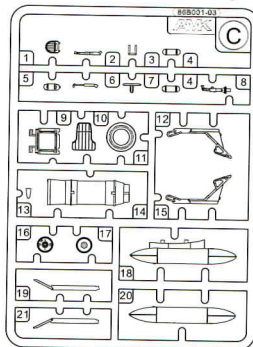

B PARTS X 1
86B001-02

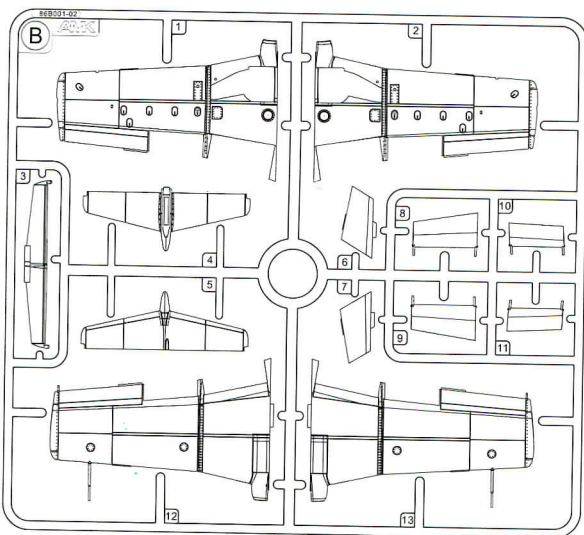

D PARTS X 1
86B001-04

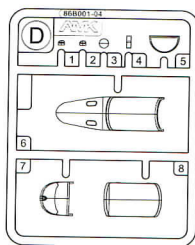

PE PARTS X 1
86B001-05

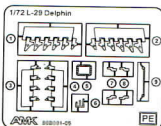

THE AERO L-29 DELFIN

The Aero L-29 Delfin (English: Dolphin, NATO reporting name: Maya) is a military jet trainer aircraft that became the standard jet trainer for the air forces of Warsaw Pact nations in the 1960s. It was Czechoslovakia's first locally designed and built jet aircraft.

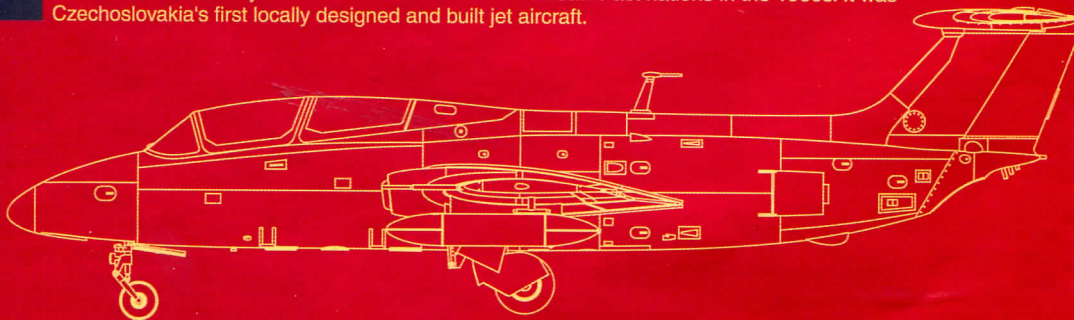

AvantGarde Model Kits (AMK) Co., Ltd.

www.amkhobby.com



 AvantgardeModelKits



9 58688 25720 033

MADE IN CHINA

© Copyright 2016, AMK

1/72 SCALE

86001

