

EE Lightning F.3

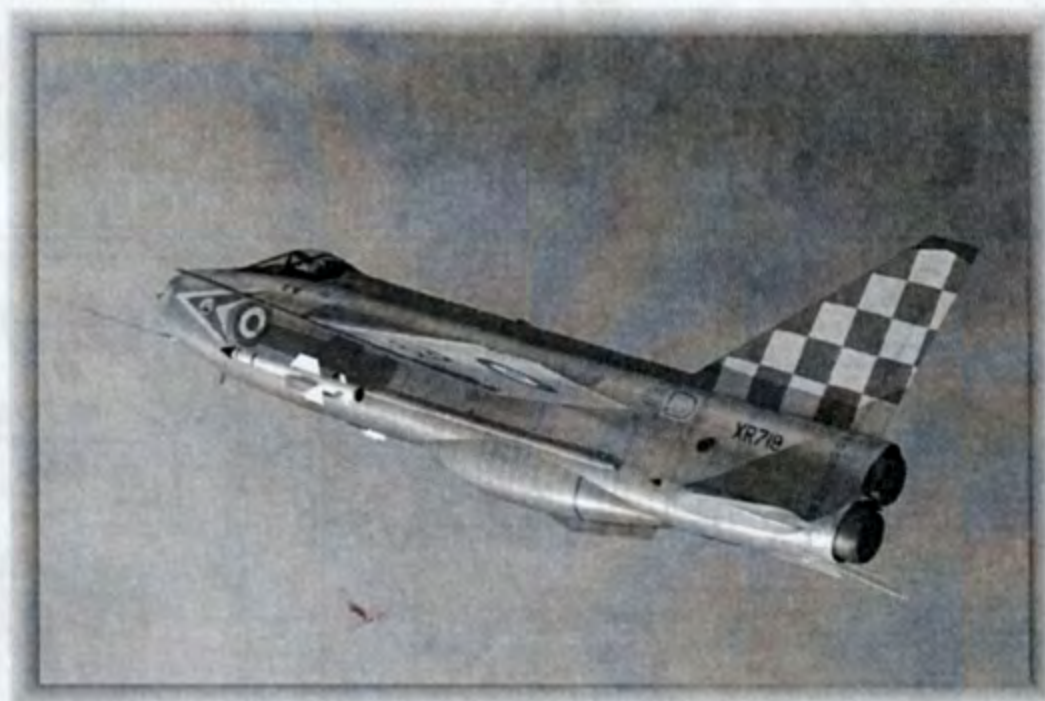

In 1947 the Ministry of Supply issued Experimental Requirement 103 for a manned research aircraft capable of exploring transsonic and supersonic speeds.

English Electric and Fairey Aviation submitted proposals, the former being designated the P.1 designed initially by W.E.W. "Teddy" Petter.

Fairey Aviation submitted proposal too in the design of the FD.2.

Design performance had been set to a maximum speed of Mach 1.5 at a height of 30,000'.

Lightning P1 - The ER103 design study was sufficiently good to be awarded by Air Ministry Requirement F.23/49 for two prototypes and a structural-test airframe. The requirement differed from E.R.103 in that the design had to incorporate military capabilities.

The design was a quite unorthodox - two engines were mounted on top of each other, the upper being slightly more forward, swept wings,

The first time a time a British aircraft was to go supersonic in level flight was on 11th August 1954. One of these two prototypes - WG760 went transsonic at 30,000 ft, but the event went unrecorded as the flight was too short.

One day later, on 12th August W/C Roland Beamont (who also had experience flying F-86 Sabre) took the aircraft to 38,000' and recorded a speed of Mach 1.02.

The transition was so smooth, it was even unnoticed, the aircraft continued to respond in a normal manner with no apparent difficulty.

There have been other tests and other prototypes, but finally it led to final design. The Lightning finally received its official name on 23 October 1958 at a ceremony which was held at Farnborough.

Lightning have been built in several variants starting F.1, followed by F.1A, F.2 and F.3 and definitive F.6, with responding trainer versions T.4 (based on F.1A) and T.5 (based on F.3).

T.4 and T.5 were two-seaters with pilots seating side by side, having a larger fin and also full armament capabilities like single versions.

Lightning have been also exported to Kuwait and Saudi Arabia.

Service with the RAF had lasted from 1960 until 1988 and now there are still flying Lightnings in private hands.

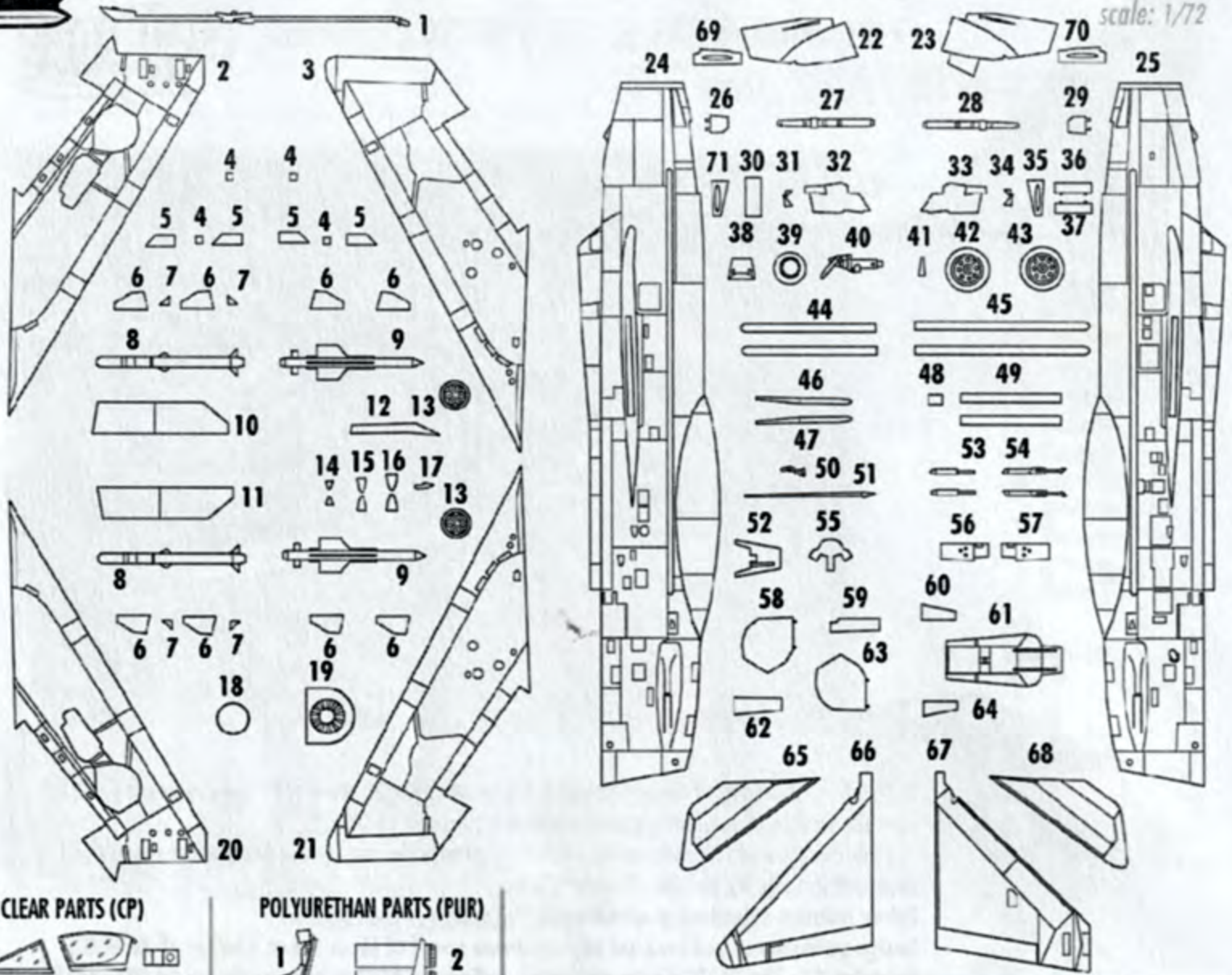

CLEAR PARTS (CP)

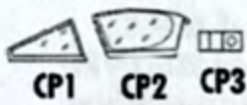

POLYURETHAN PARTS (PUR)

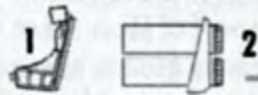

PHOTO-ETCHED PARTS (PP)



OHNOUT
BEND



VRTAT
OPEN HOLE



VYROBIT
SCRATCH BUILD



VTERINOVÉ LEPIDLO
CYANOACRYLATE GLUE



SYMETRICKÁ MONTÁŽ
SYMETRICAL ASSEMBLY



VOLBA
OPTION



ODSARNIT
REMOVE

BARVA/COLOR

- A** ČERNÁ/BLACK
- B** INTERIOVÁ ČERNÁ
INTERIOR BLACK
- C** STŘÍBRNÁ/SILVER
- D** HLINÍK/ALUMINIUM
- E** ČERVENÁ/RED
- F** ŽLUTÁ/YELLOW
- G** OLIVOVÁ
OLIVE
- H** PÍSKOVÁ
SAND
- I** CHROM/CHROME
- J** HNĚDÁ/BROWN
- K** KOV/GAIN METAL
- L** ŠEDÁ/GREY
- M** PNEU/TYRE BLACK

F.3

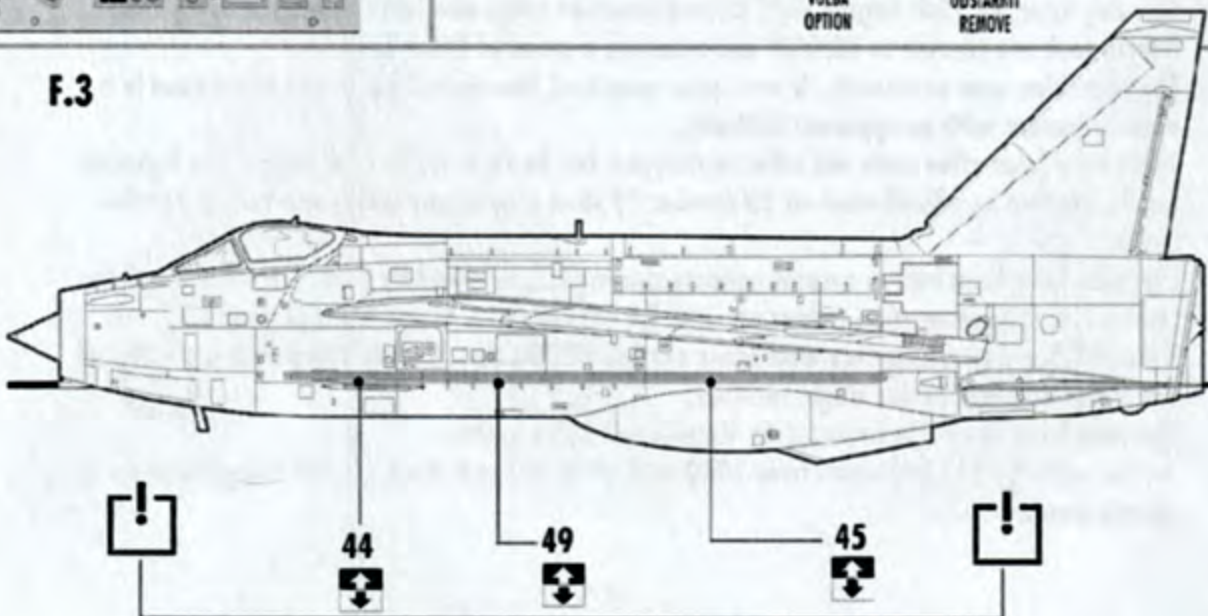

STEP 1

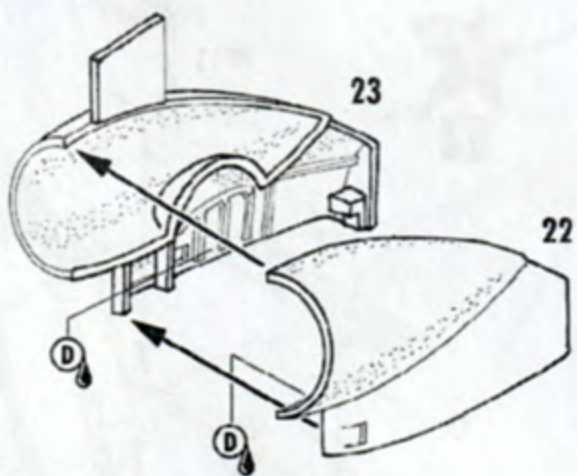

STEP 2

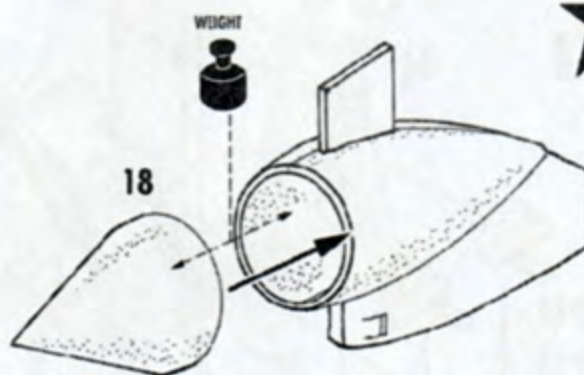

STEP 3

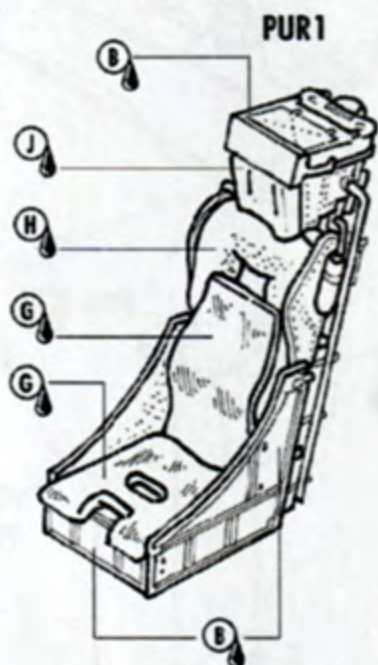

STEP 4

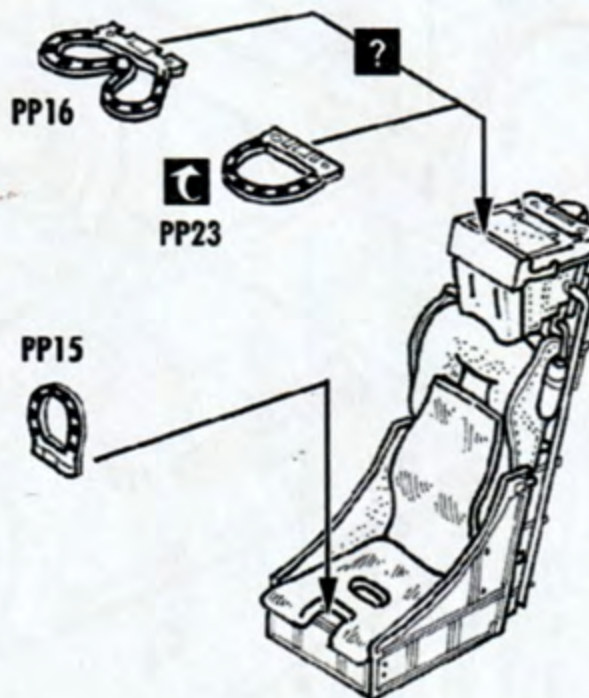

STEP 5

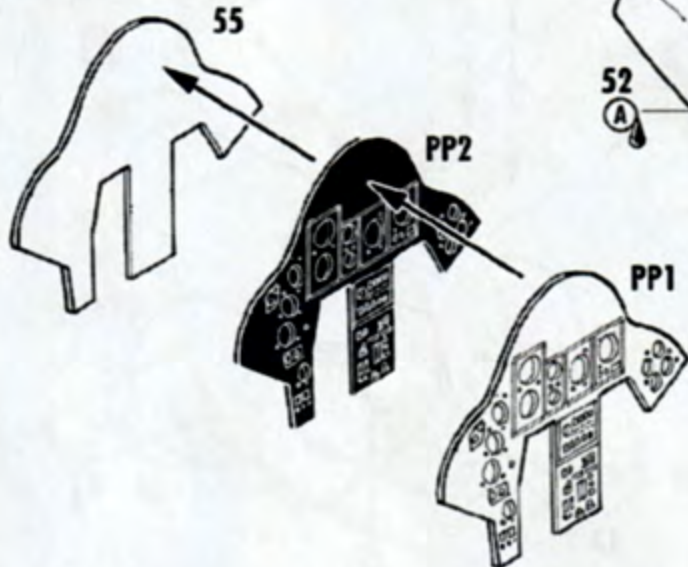

STEP 6

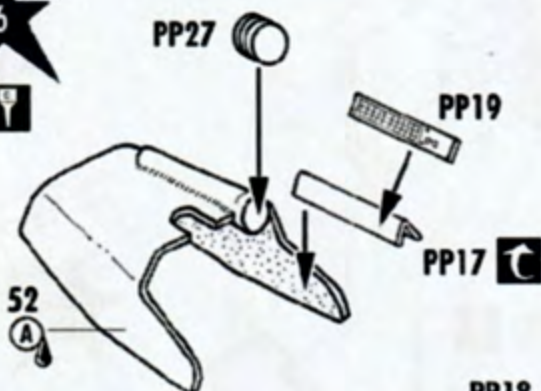

STEP 7

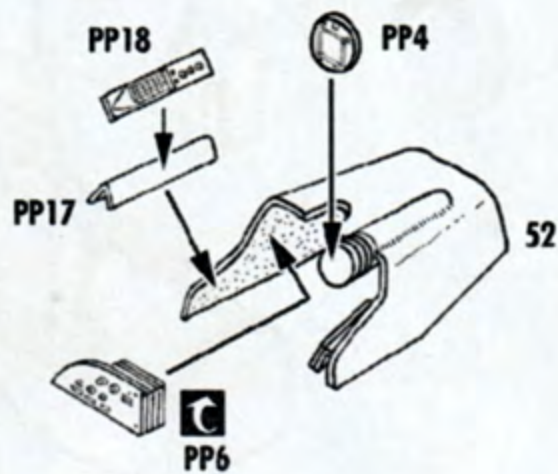

STEP 8

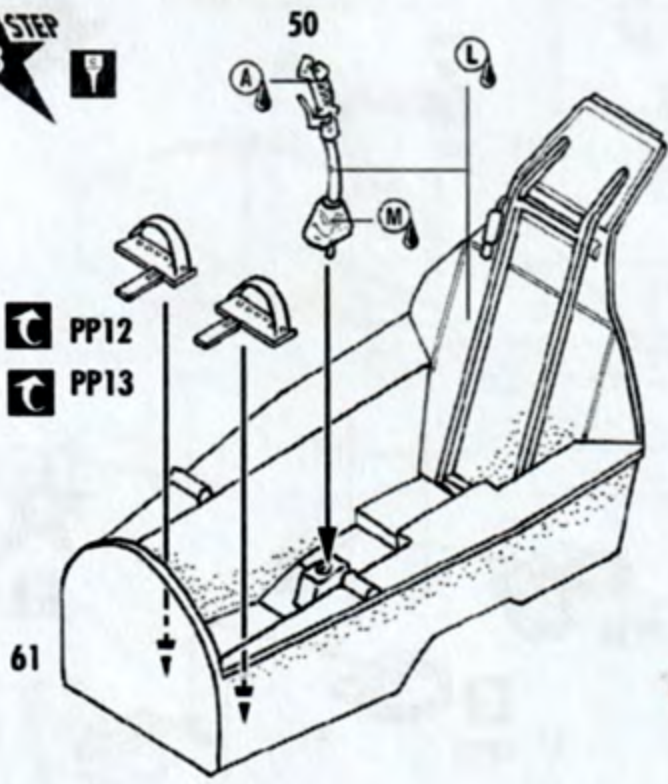

STEP 9

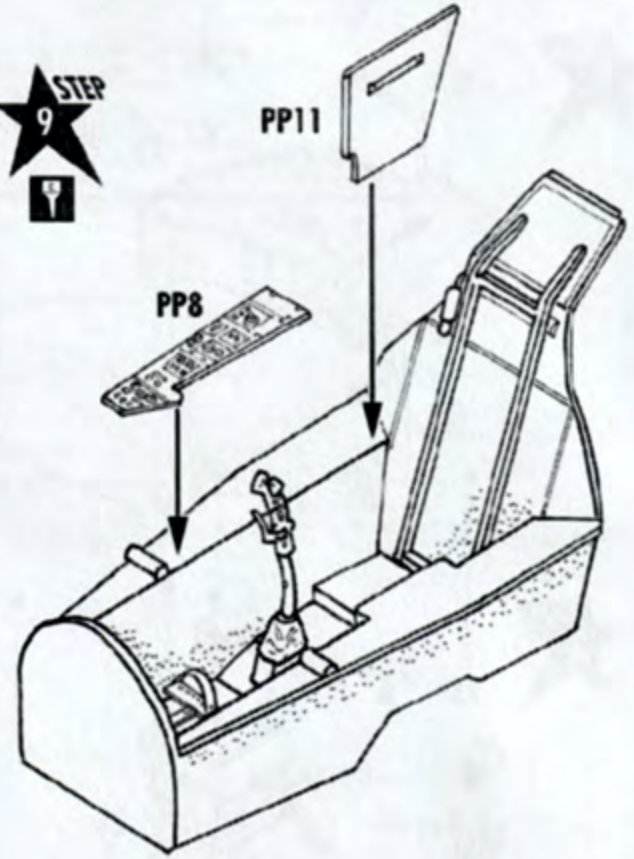

STEP 10

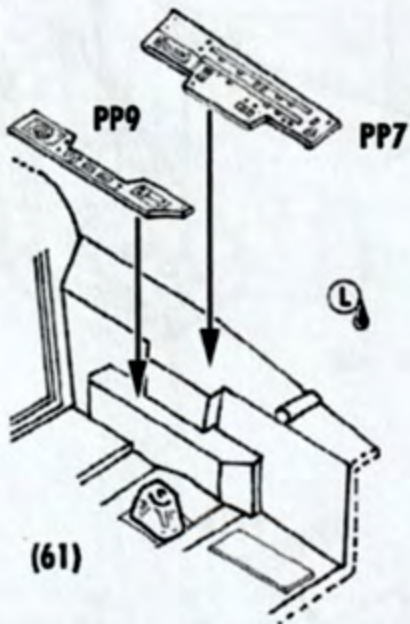

STEP 11

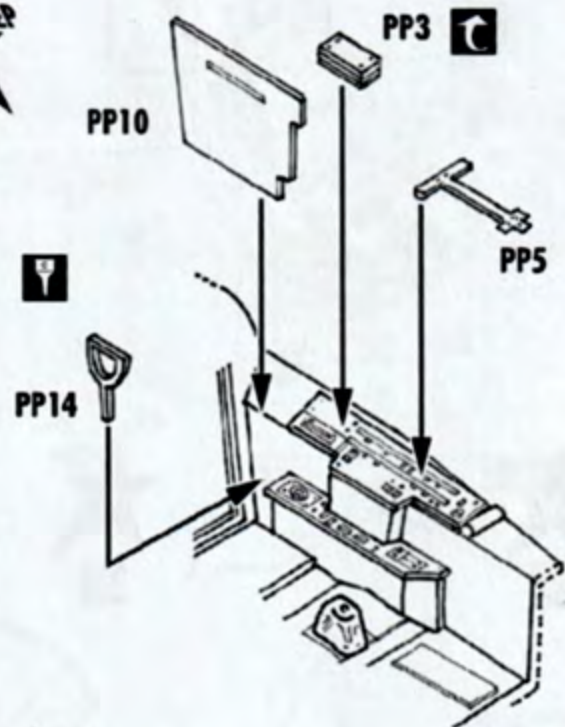

STEP 12

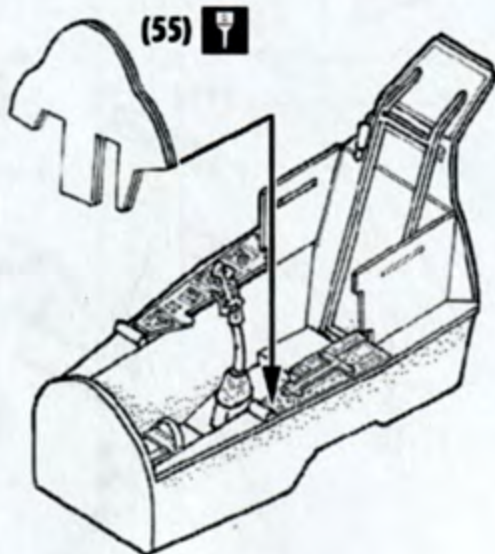

STEP 13

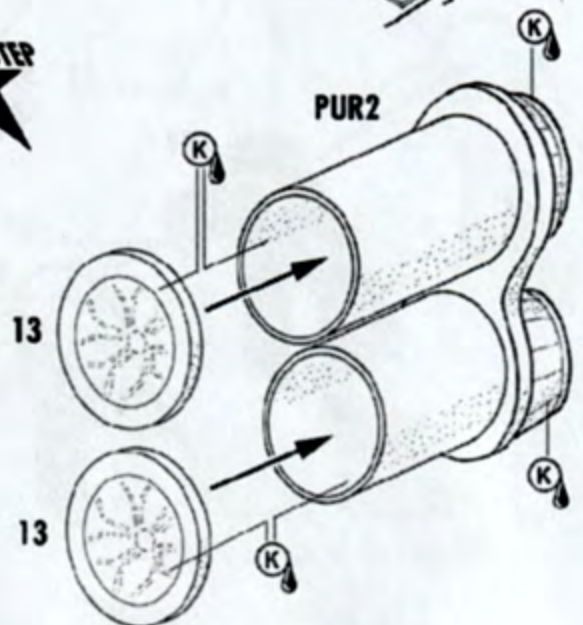

STEP
14

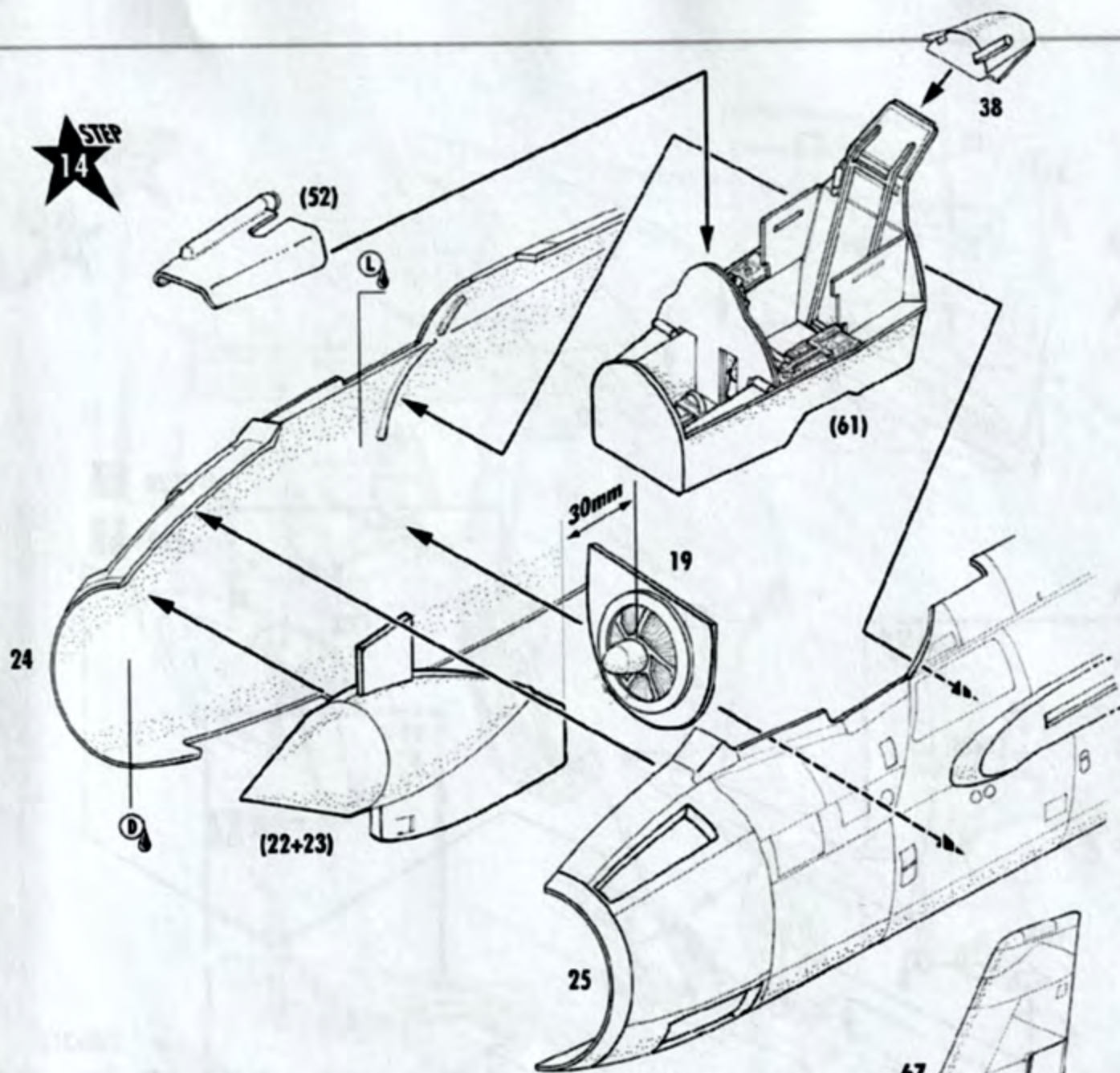

STEP
16

STEP
15

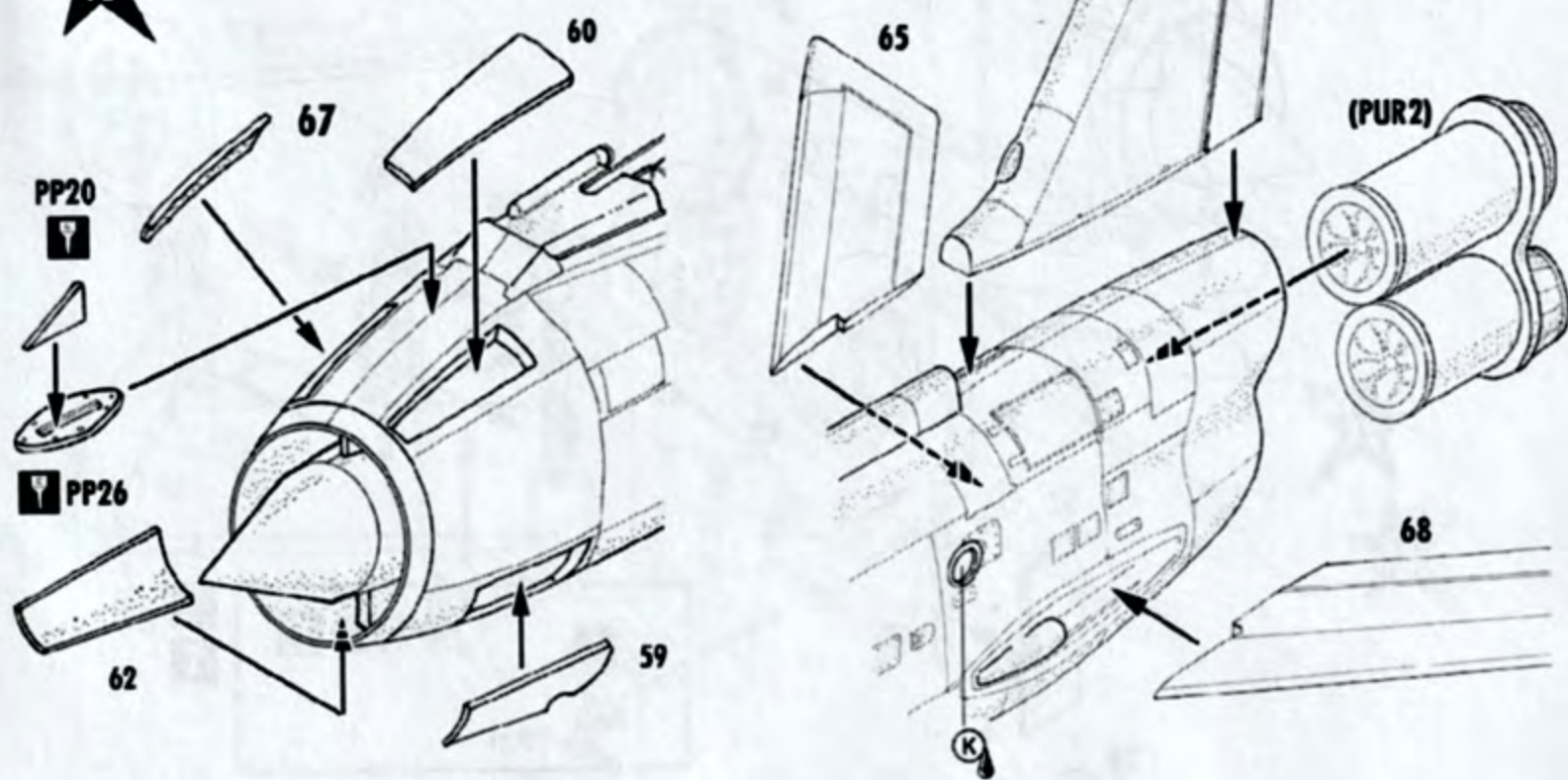

STEP
18

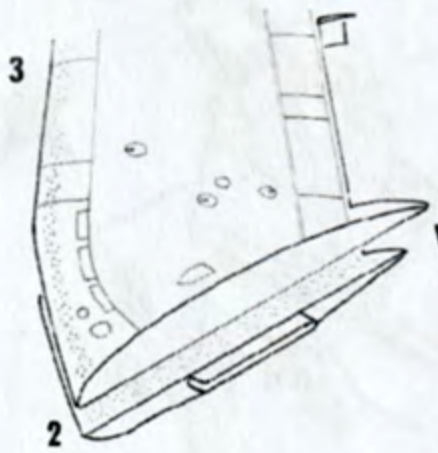

STEP
19

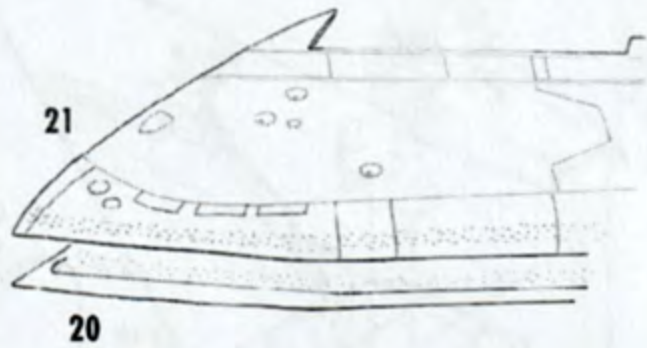

STEP
20

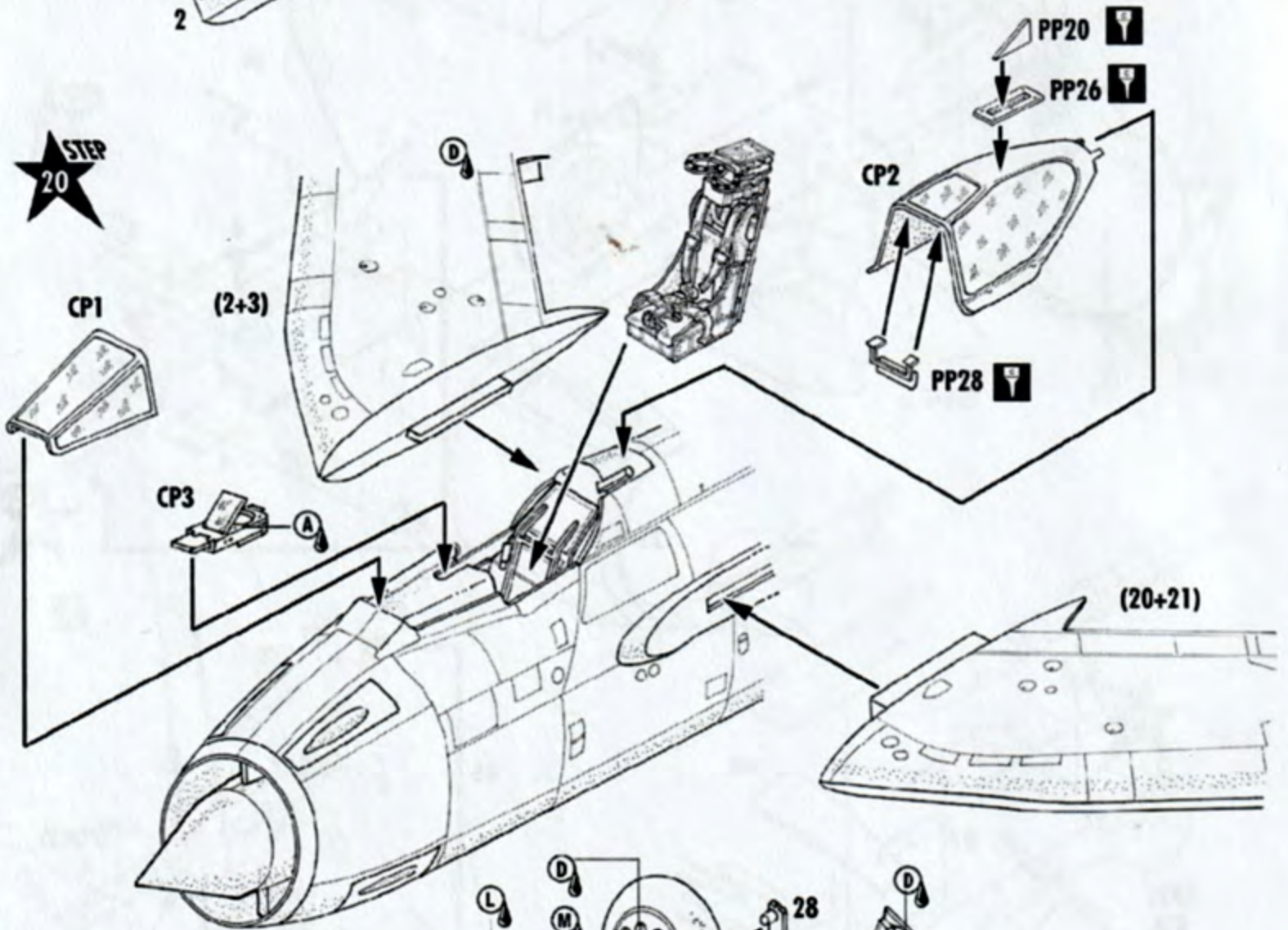

STEP
21

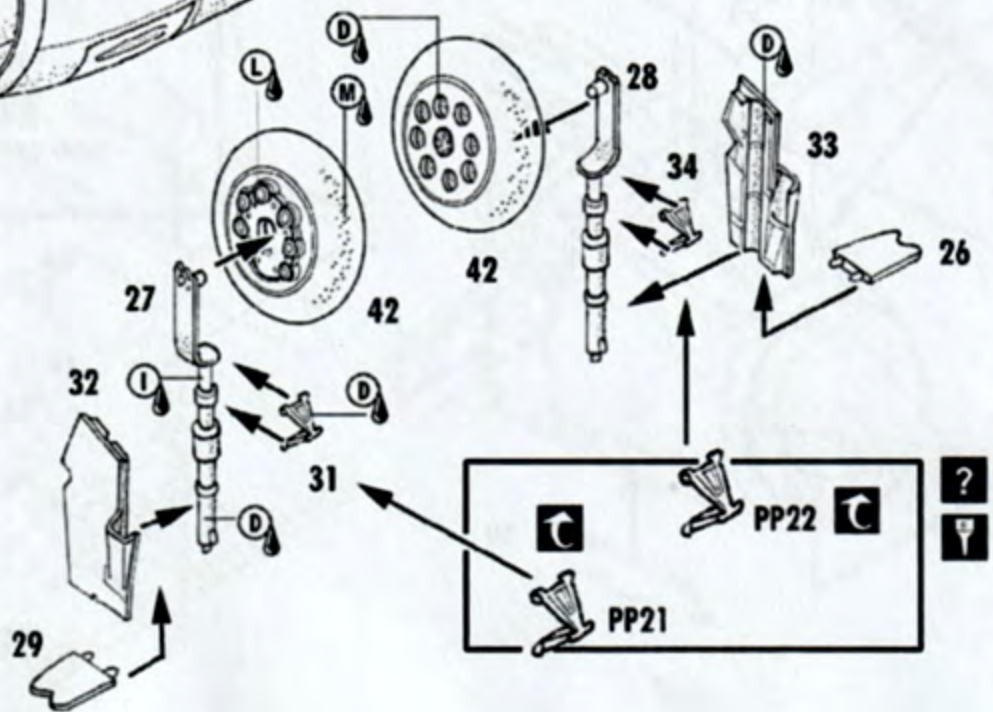

STEP
22

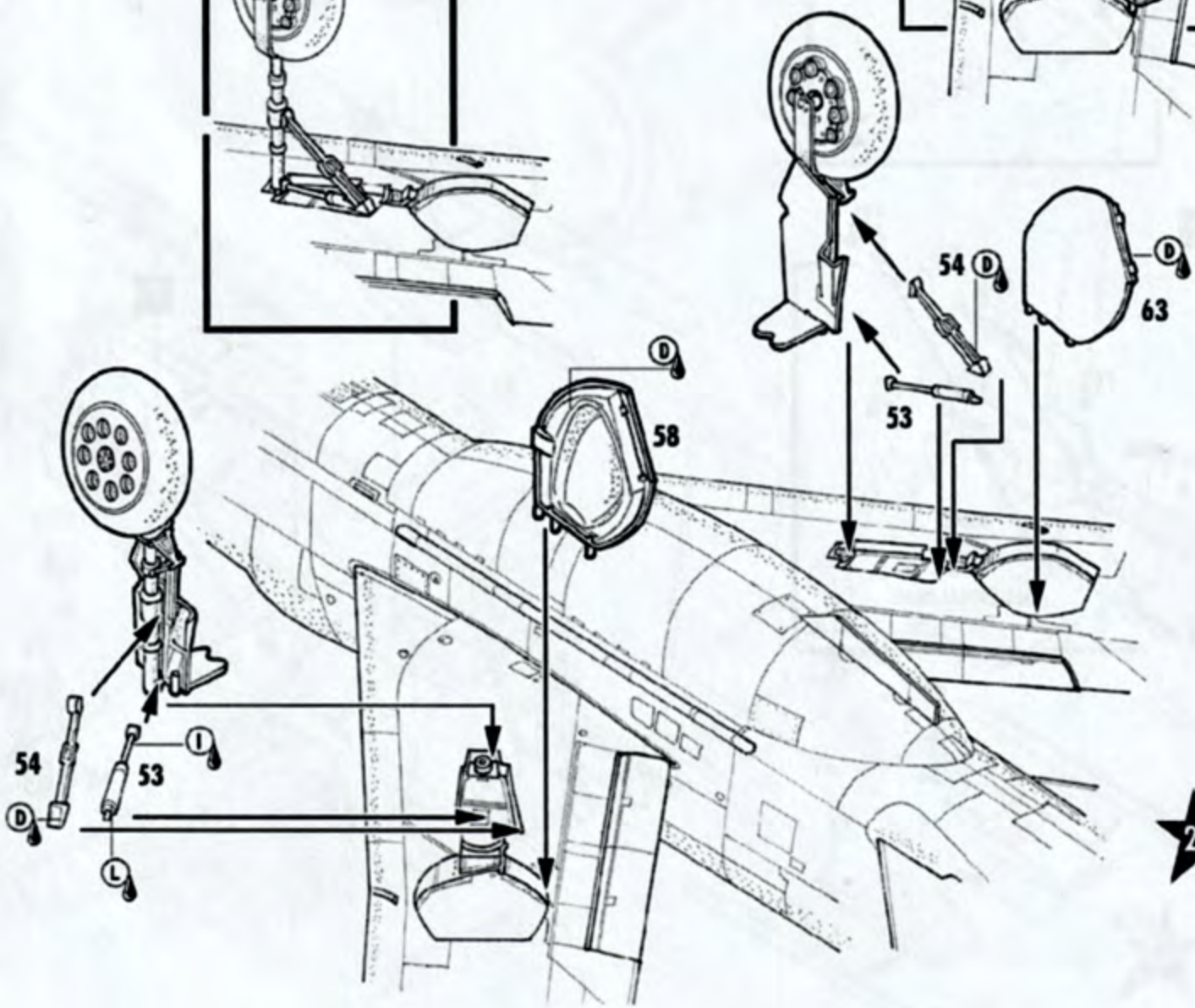
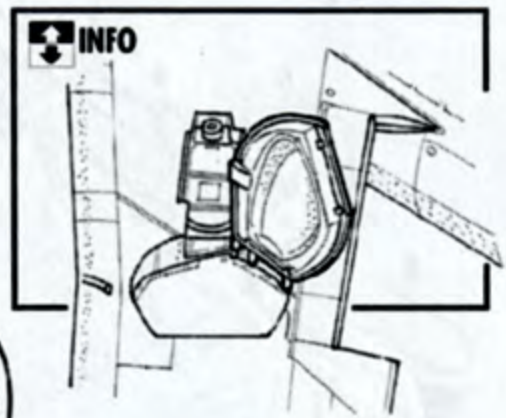
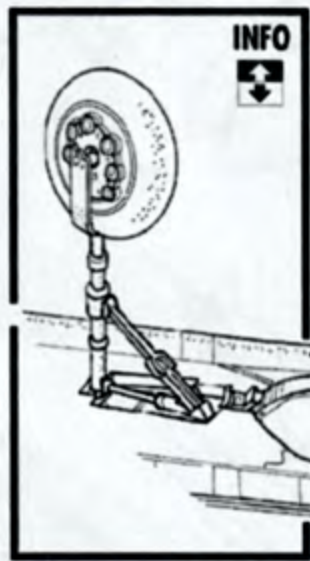
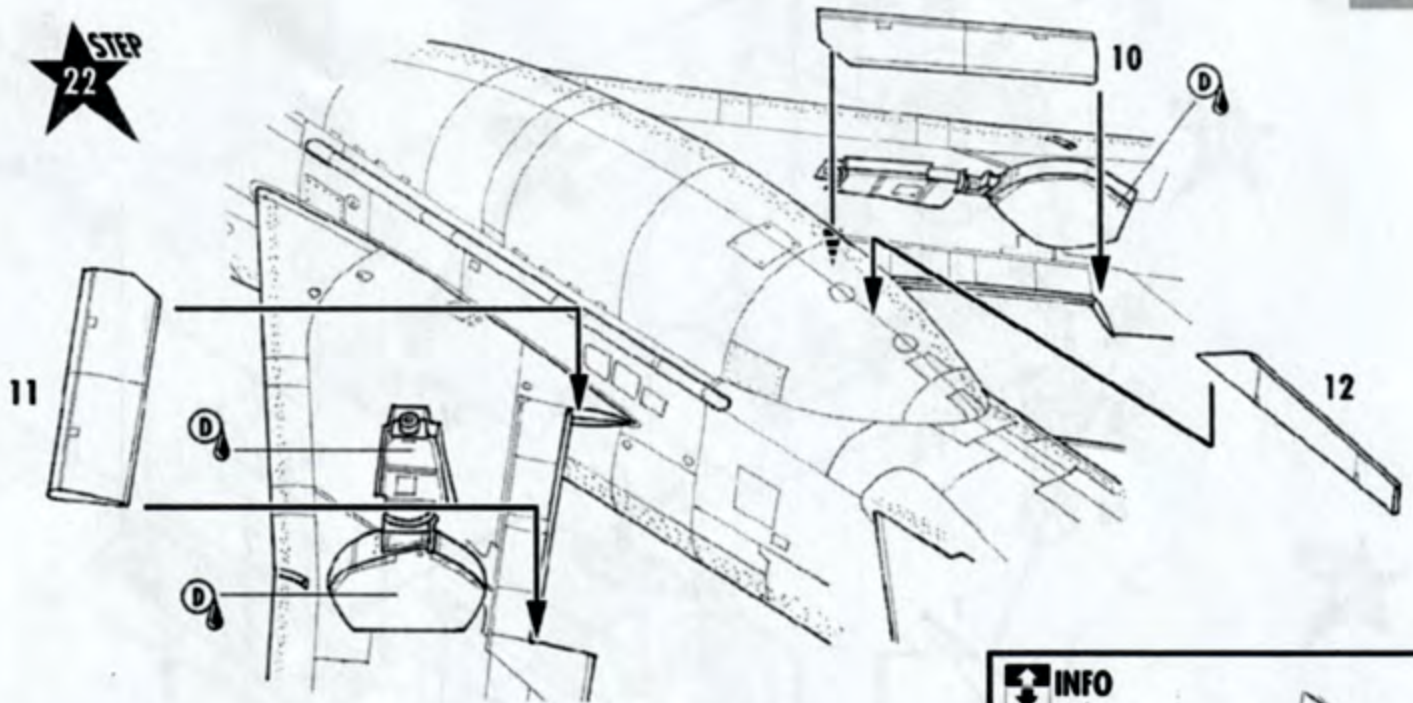

STEP
23

STEP 24

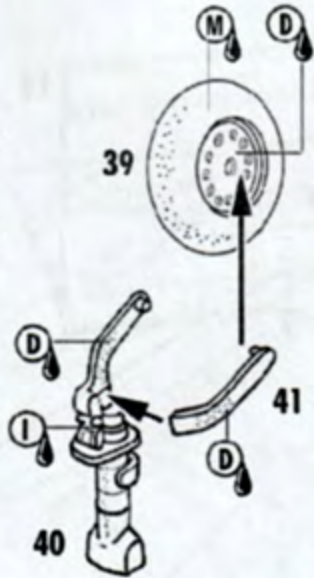

STEP 25

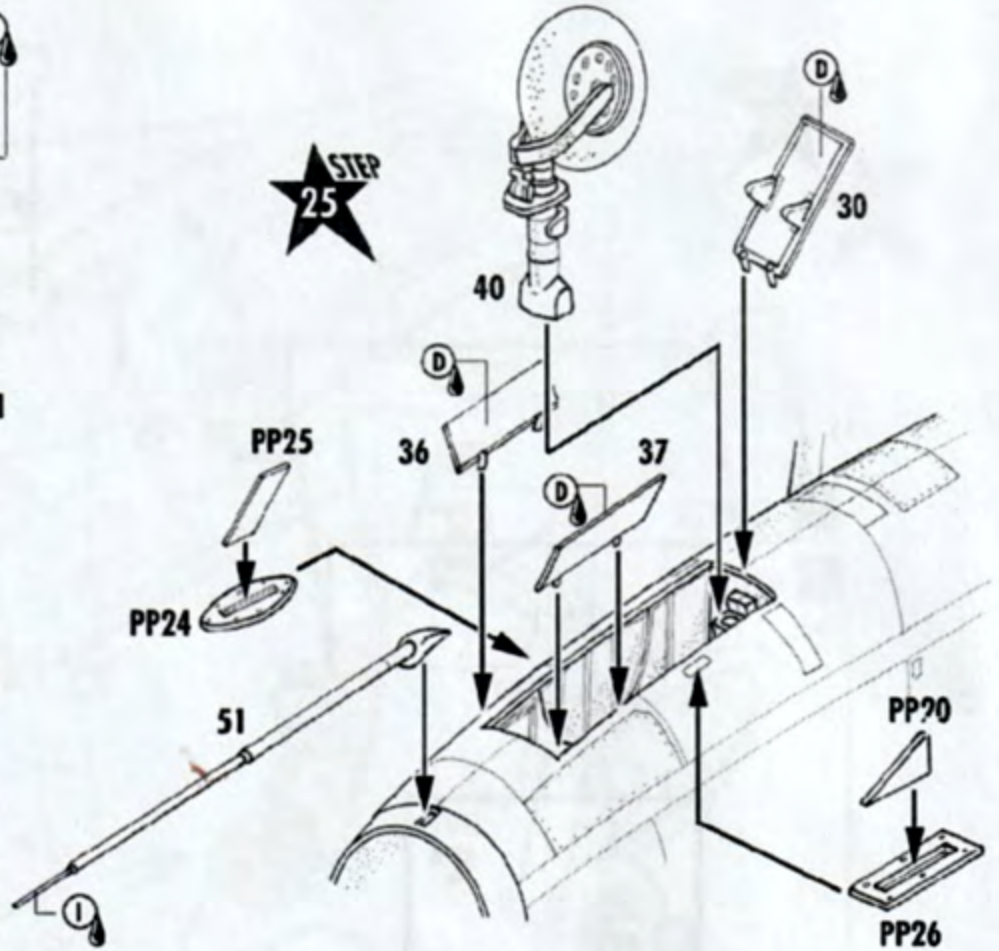

STEP 26

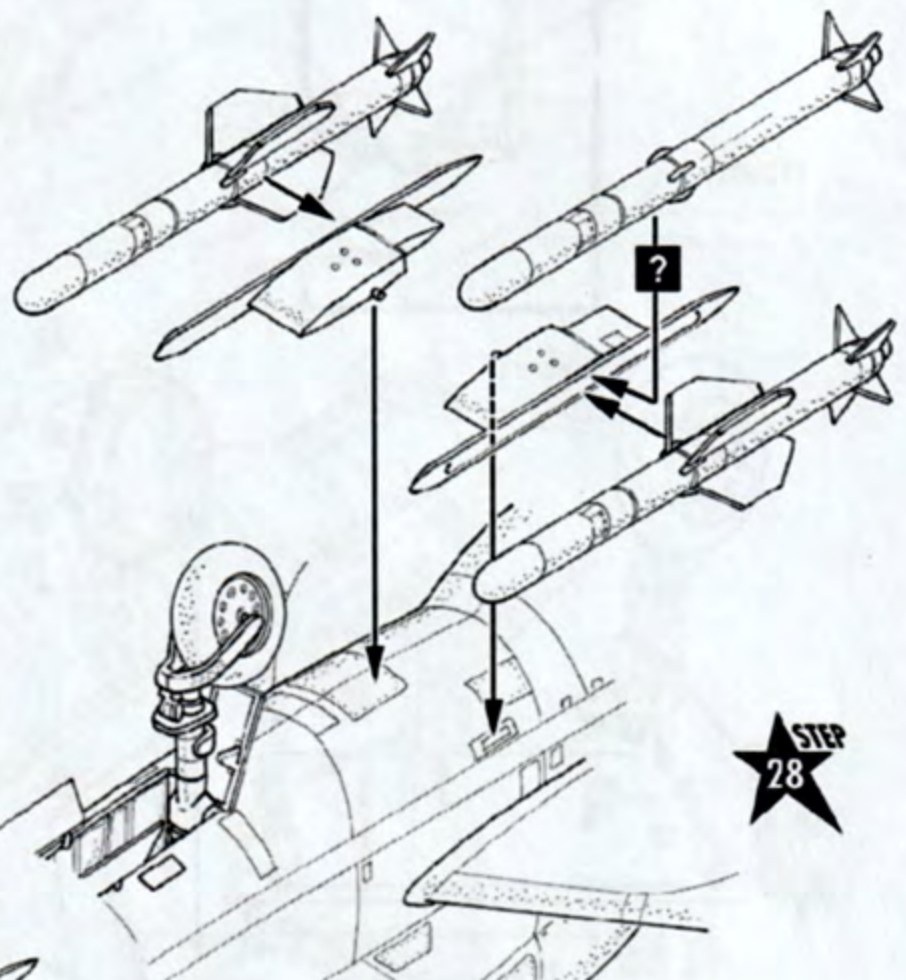
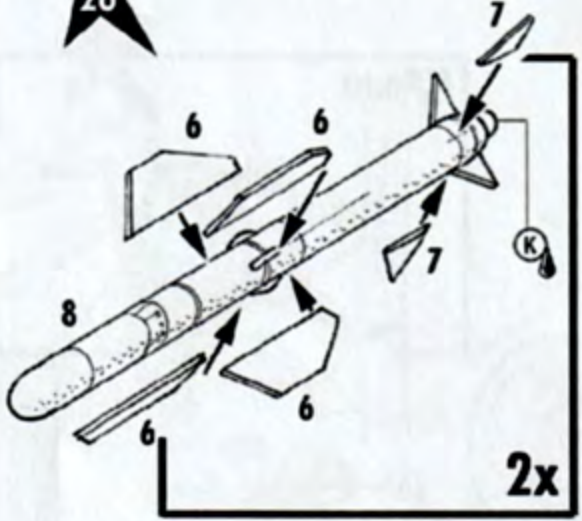

STEP 28

?

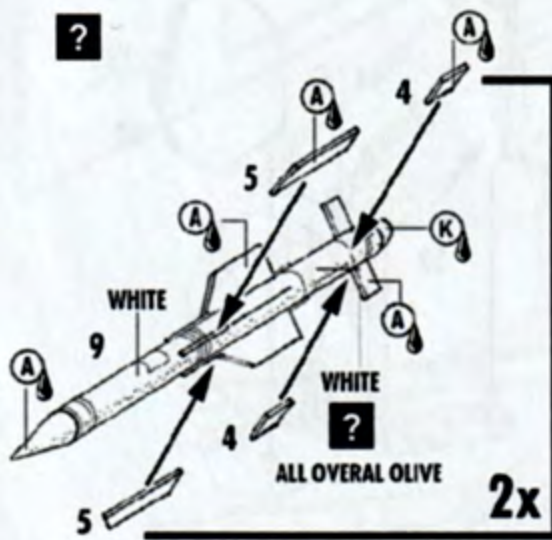

STEP 27

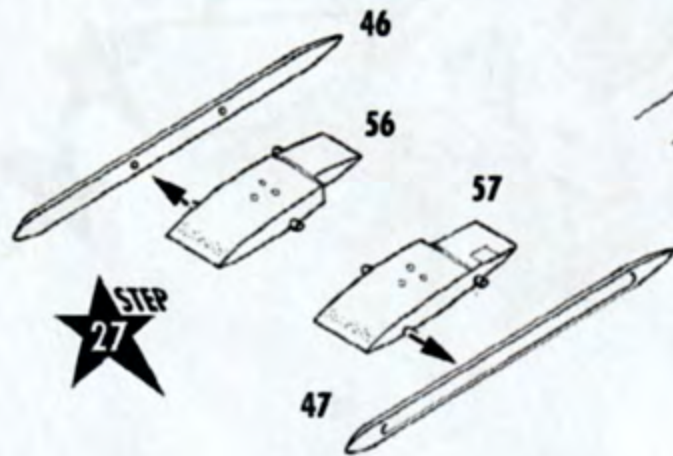

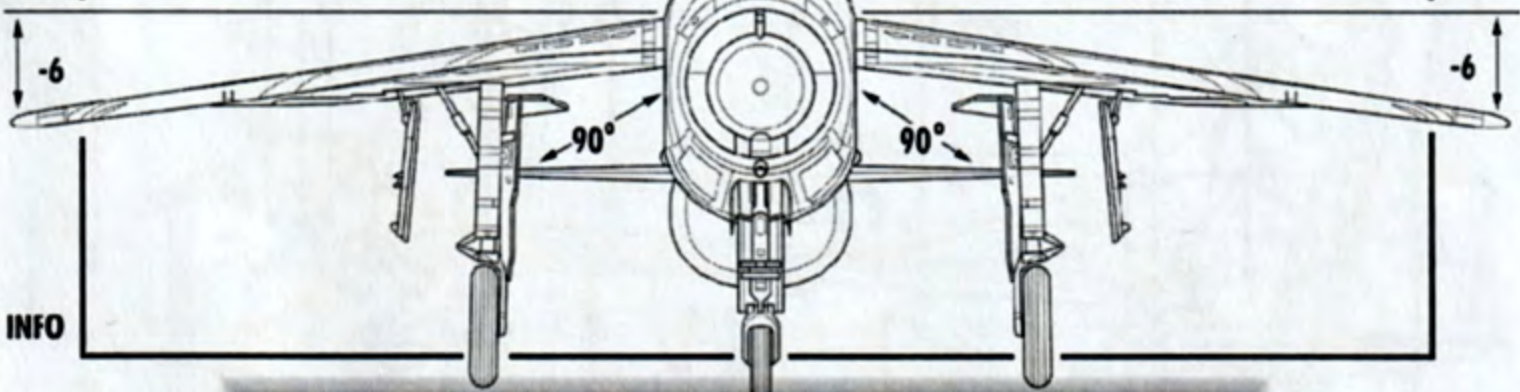
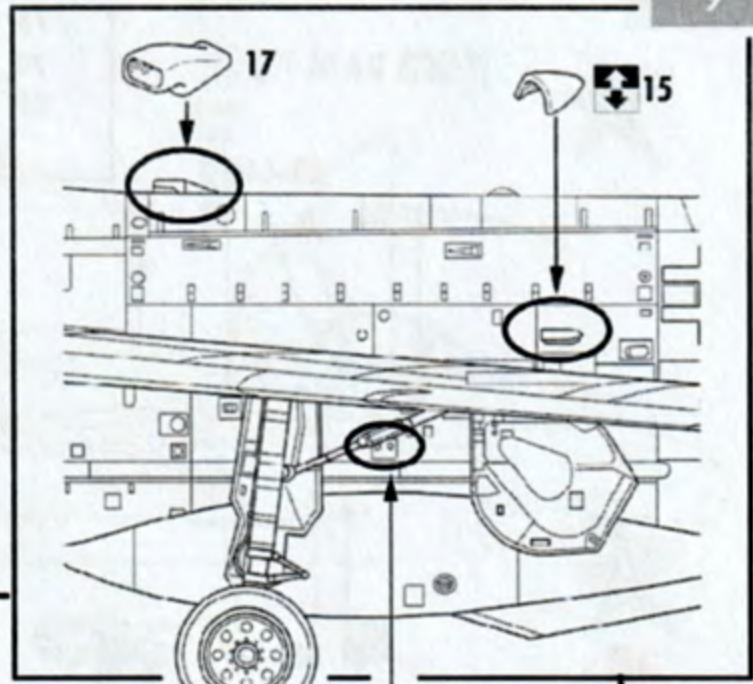
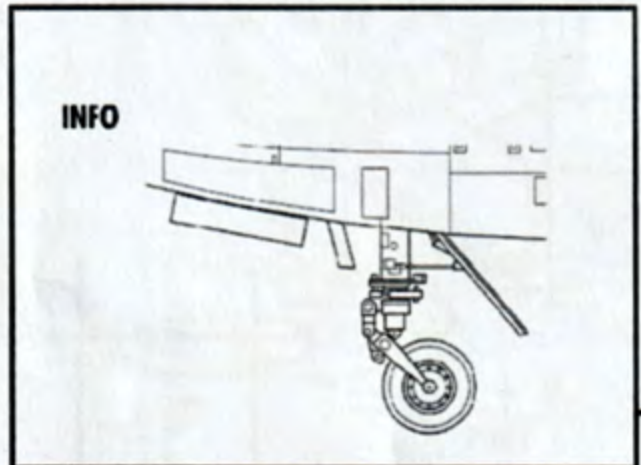

STENCIL DATA F.3

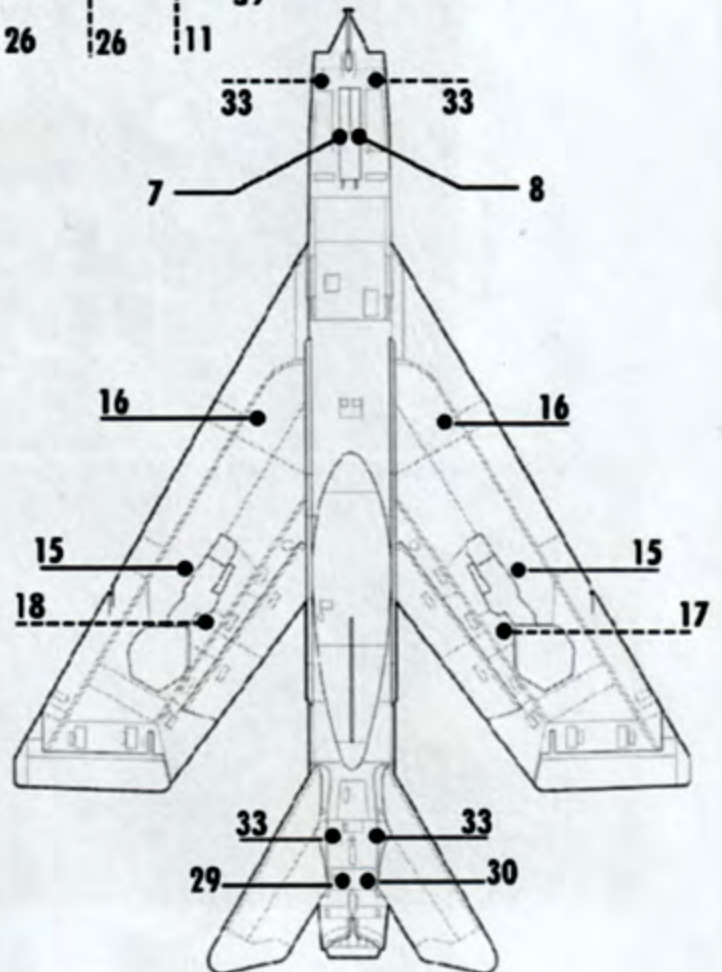
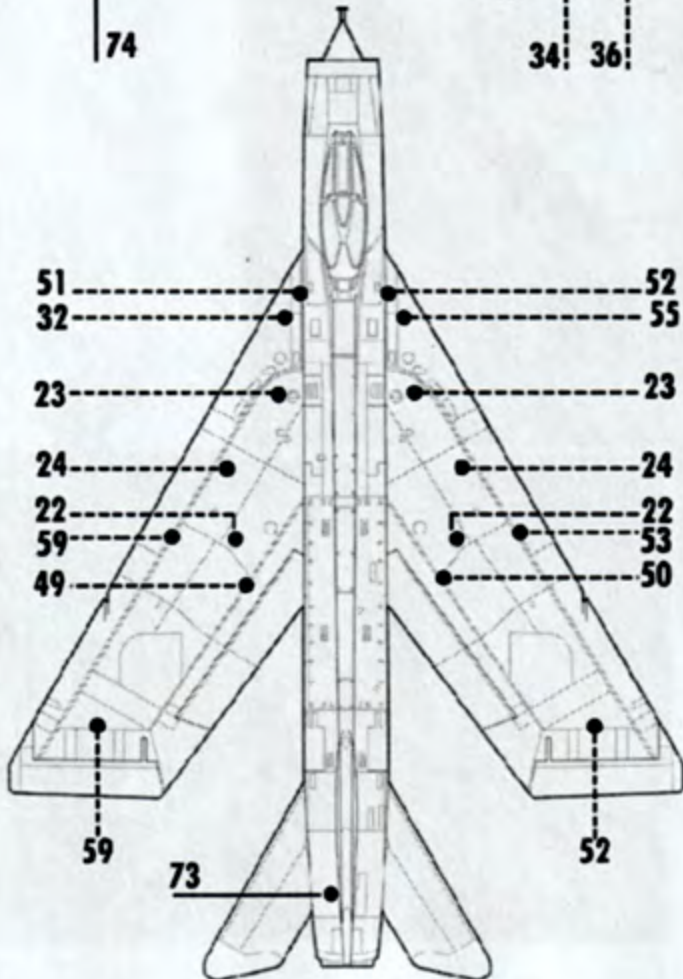
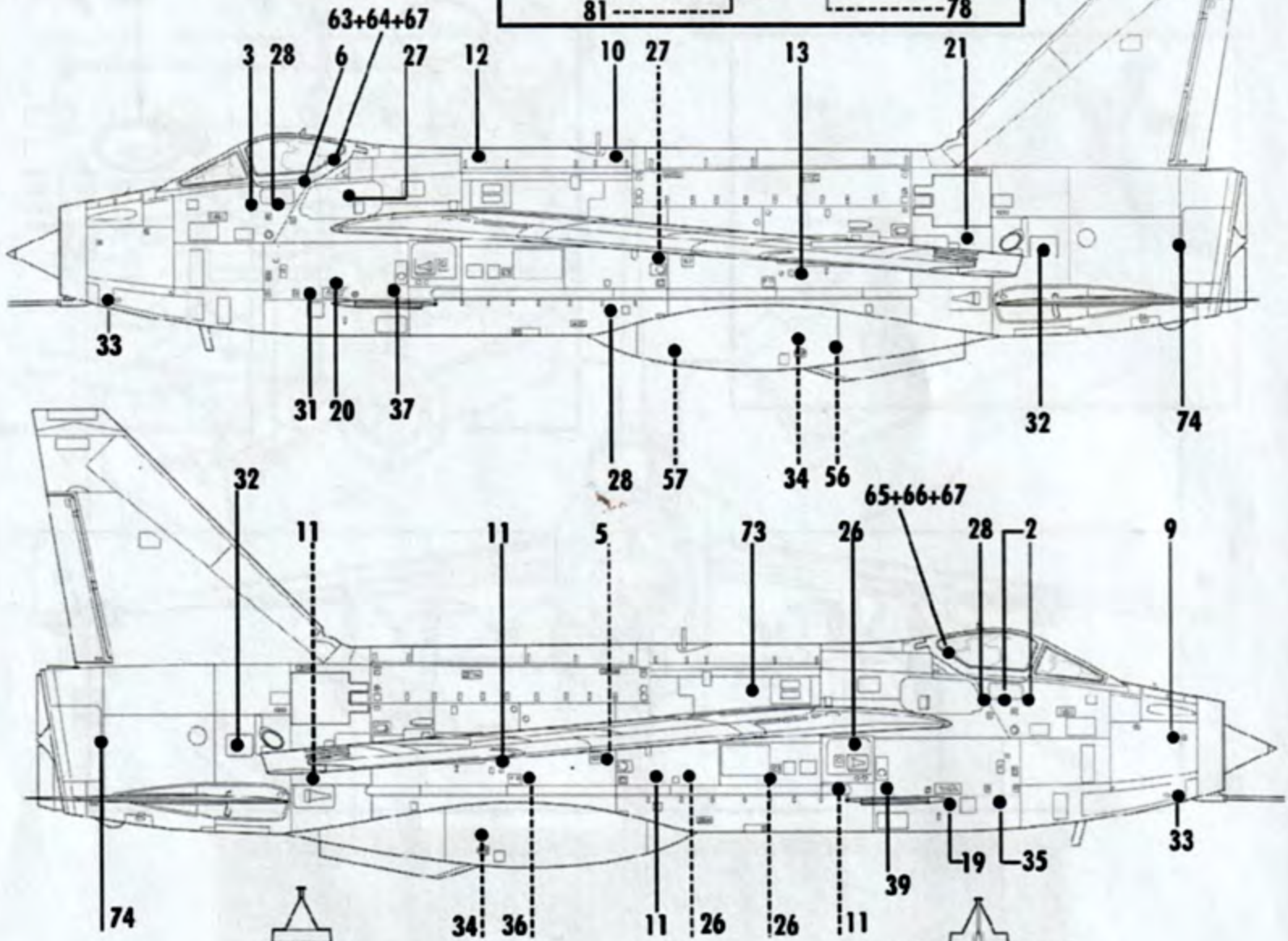
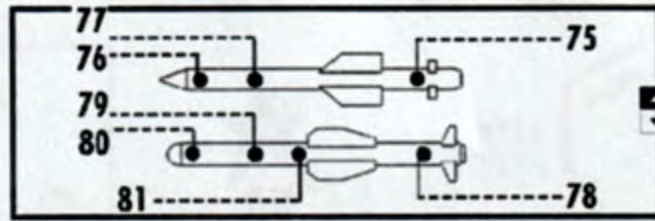

A

Lightning F3, XR719/D, 56. Sq. RAF, Lakenheat 1965

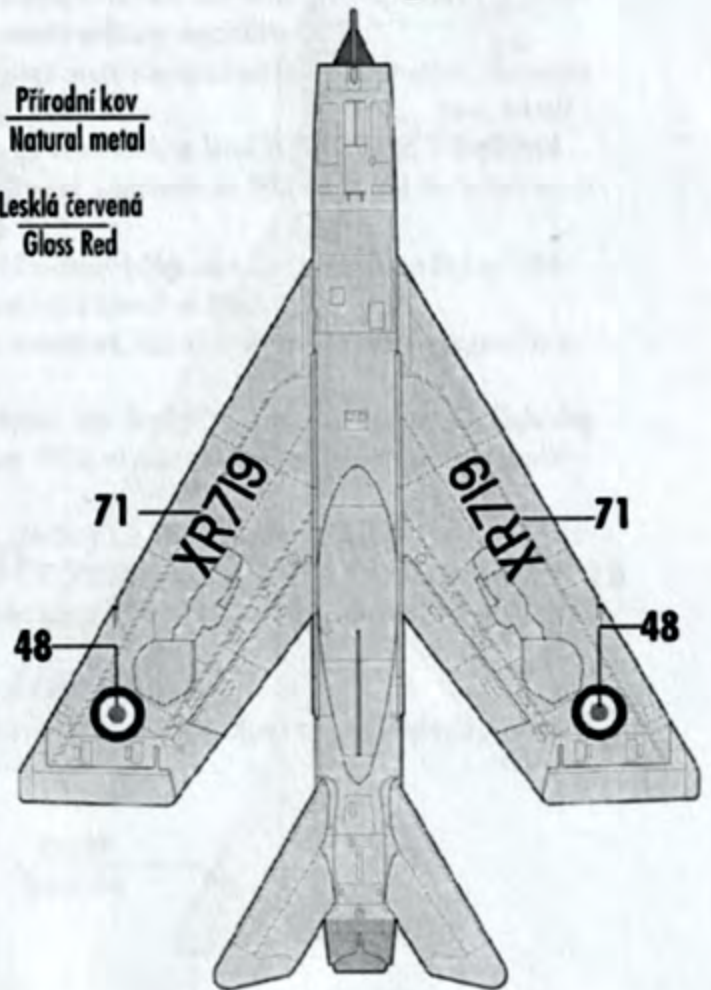
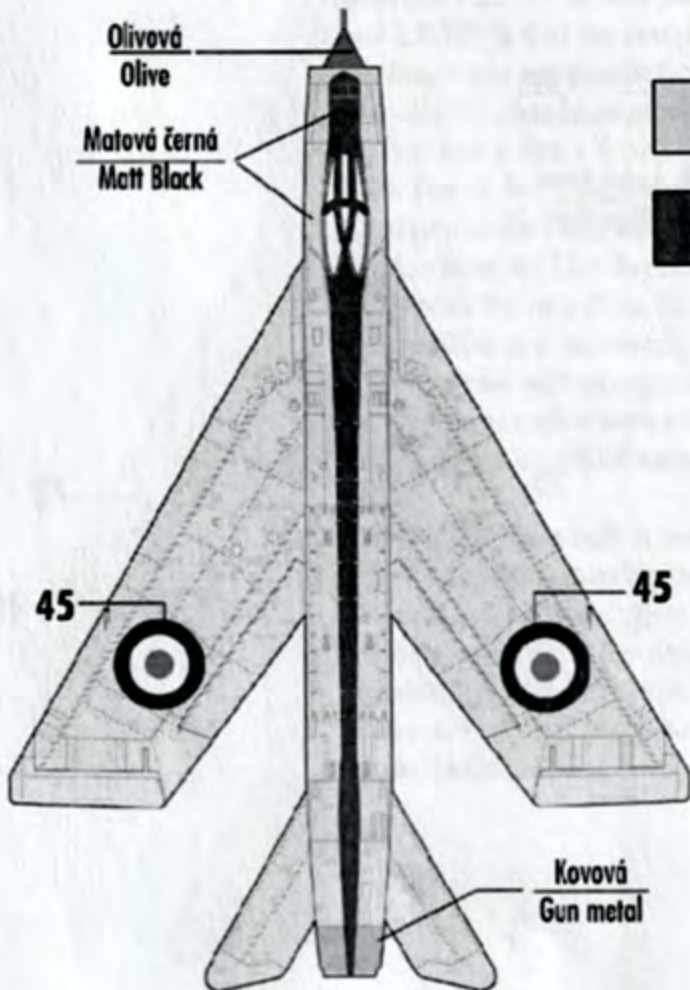
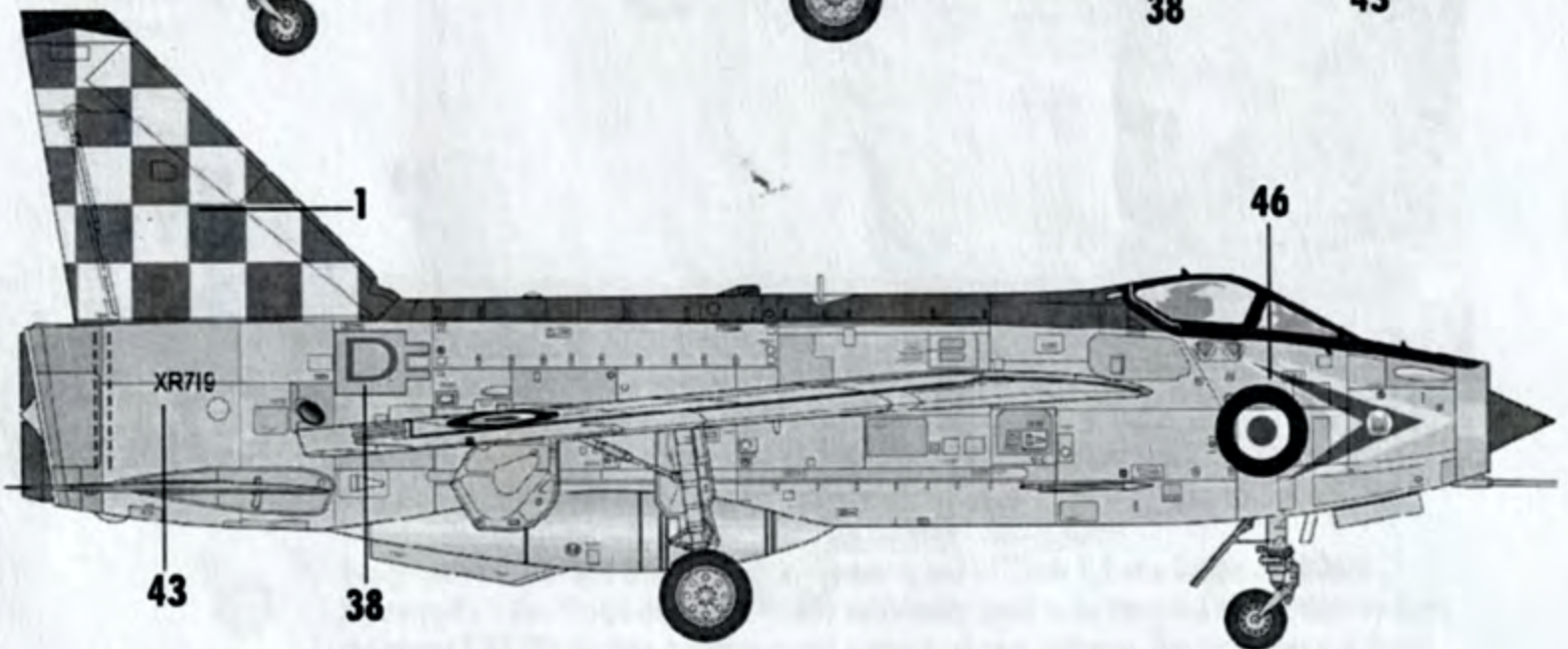
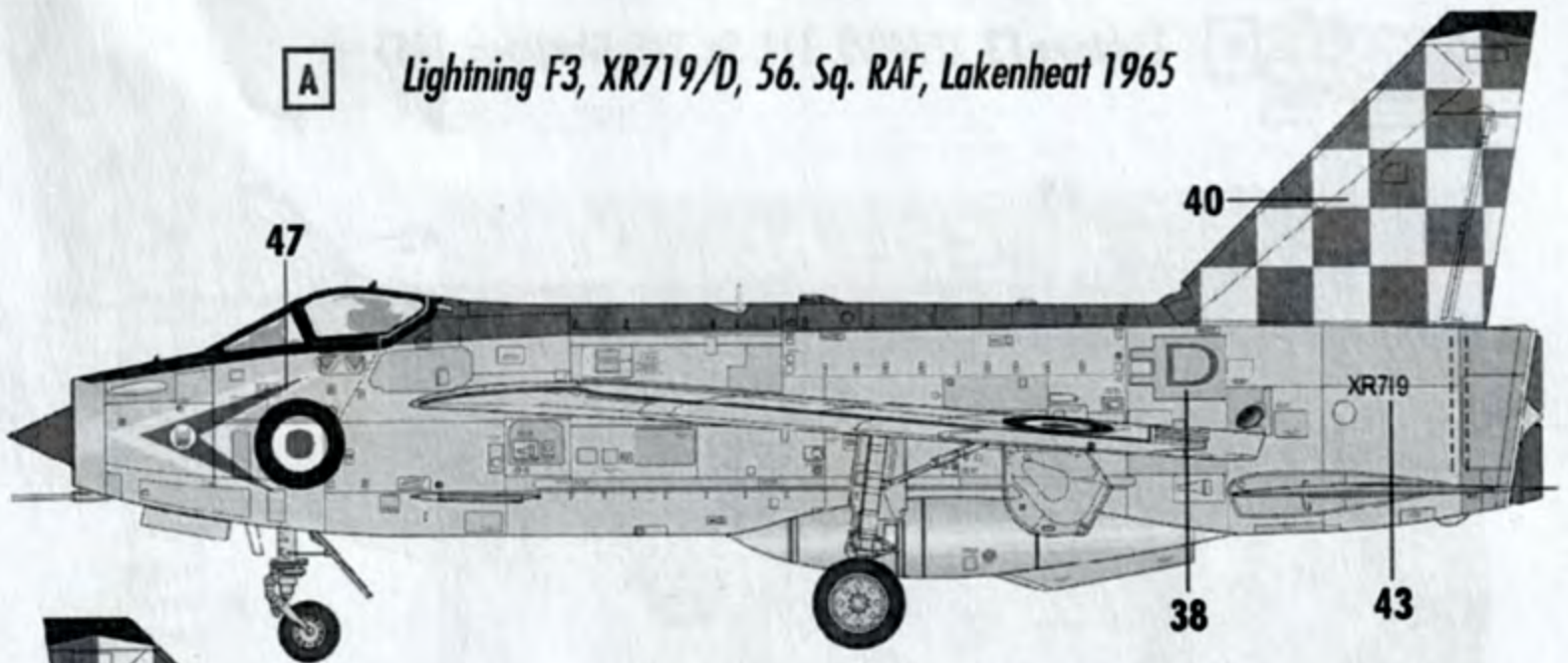

Olivová
Olive

Matová černá
Matt Black

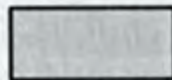

Přirodní kov
Natural metal



Lesklá červená
Gloss Red

Kovová
Gun metal

B Lightning F3, XP740/J, 111. Sq. RAF, Wattisham 1965

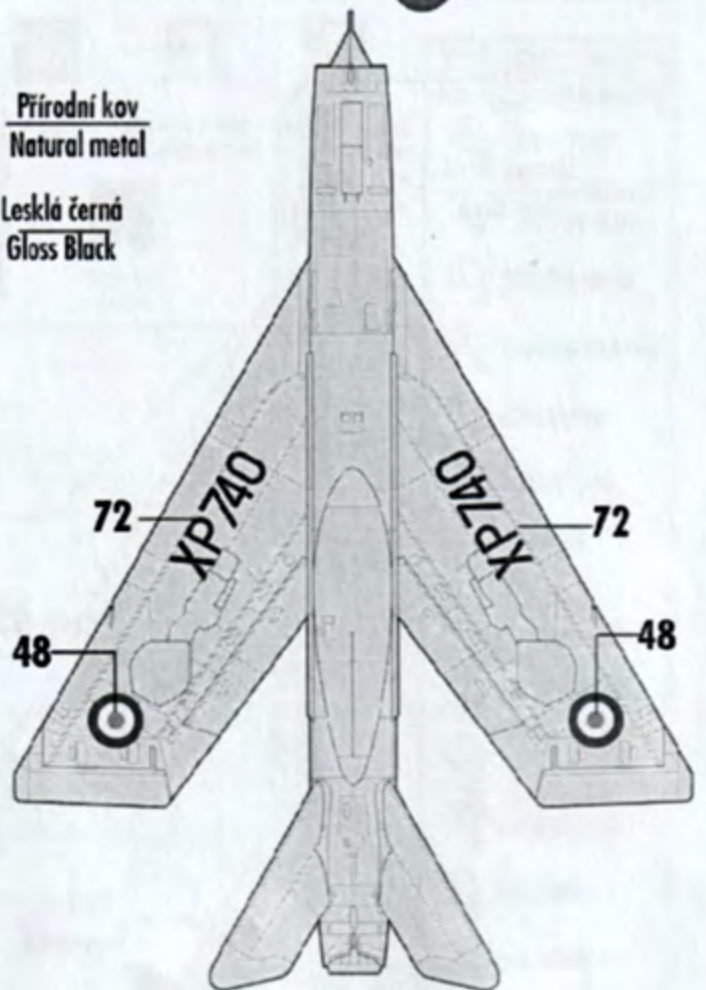
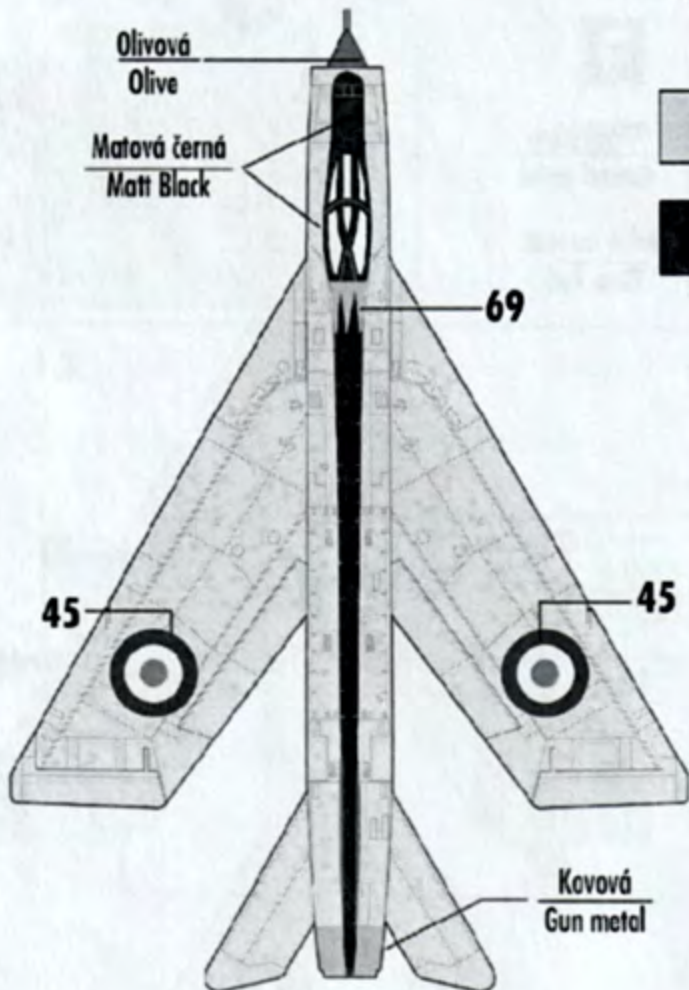
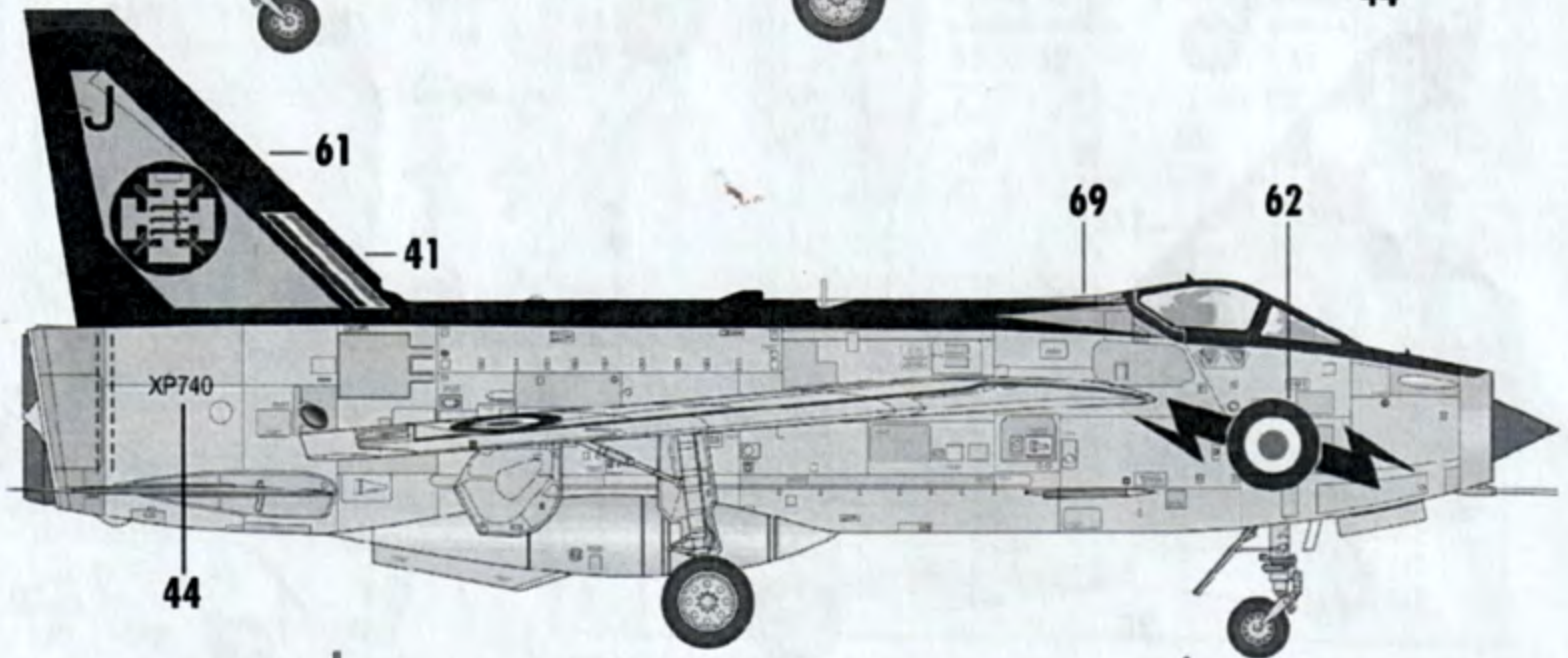
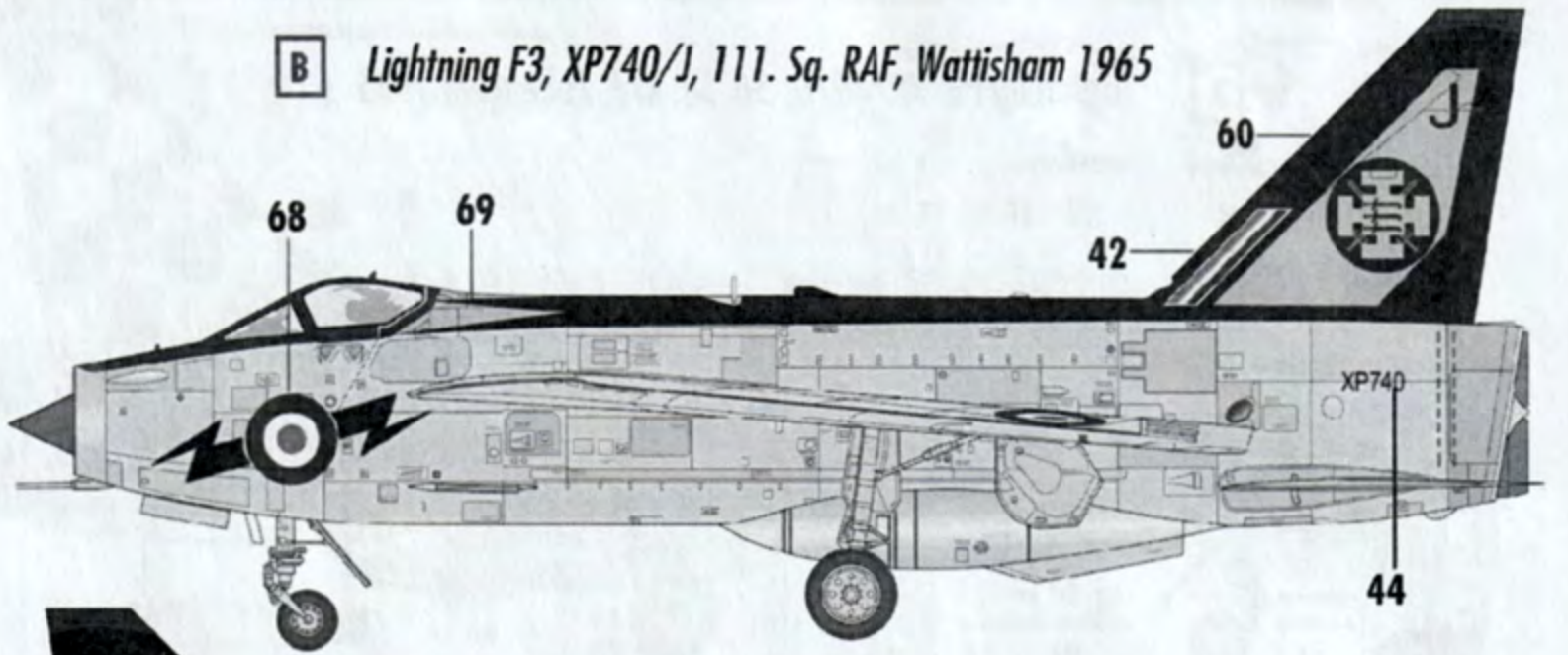

Olivová
Olive

Matová černá
Matt Black

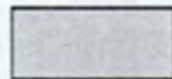

Přírodní kov
Natural metal



Lesklá černá
Gloss Black

Kovová
Gun metal

EE Lightning F3



Lightning F3, XP740/J, 111. Sq. RAF, Wattisham 1965

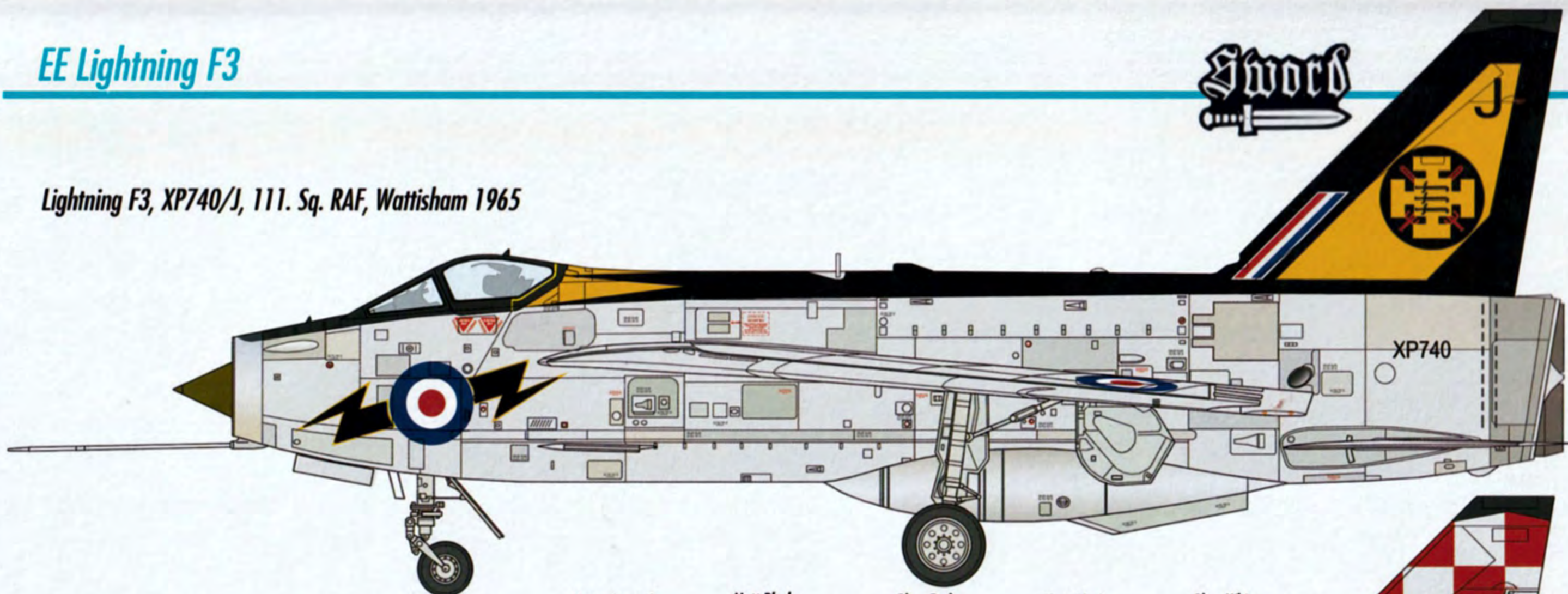

Natural metal

Matt Black

Gloss Red

Gloss Black

Gloss White

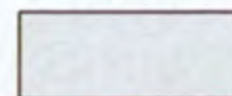
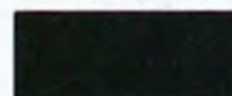
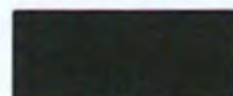

Lightning F3, XR719/D, 56. Sq. RAF, Lakenheat 1965

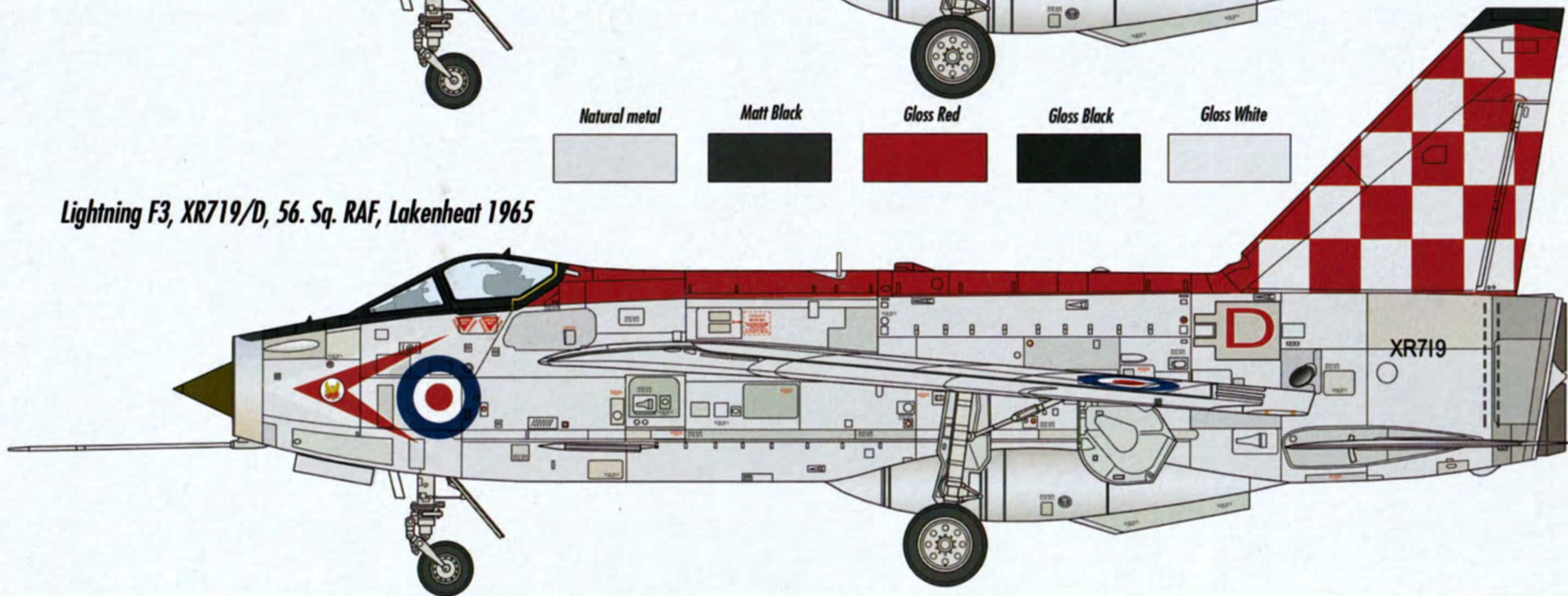

SW 72082(scale 1/72)