

ENCORE

MODELS

I-15 bis

Soviet Fighter-Biplane

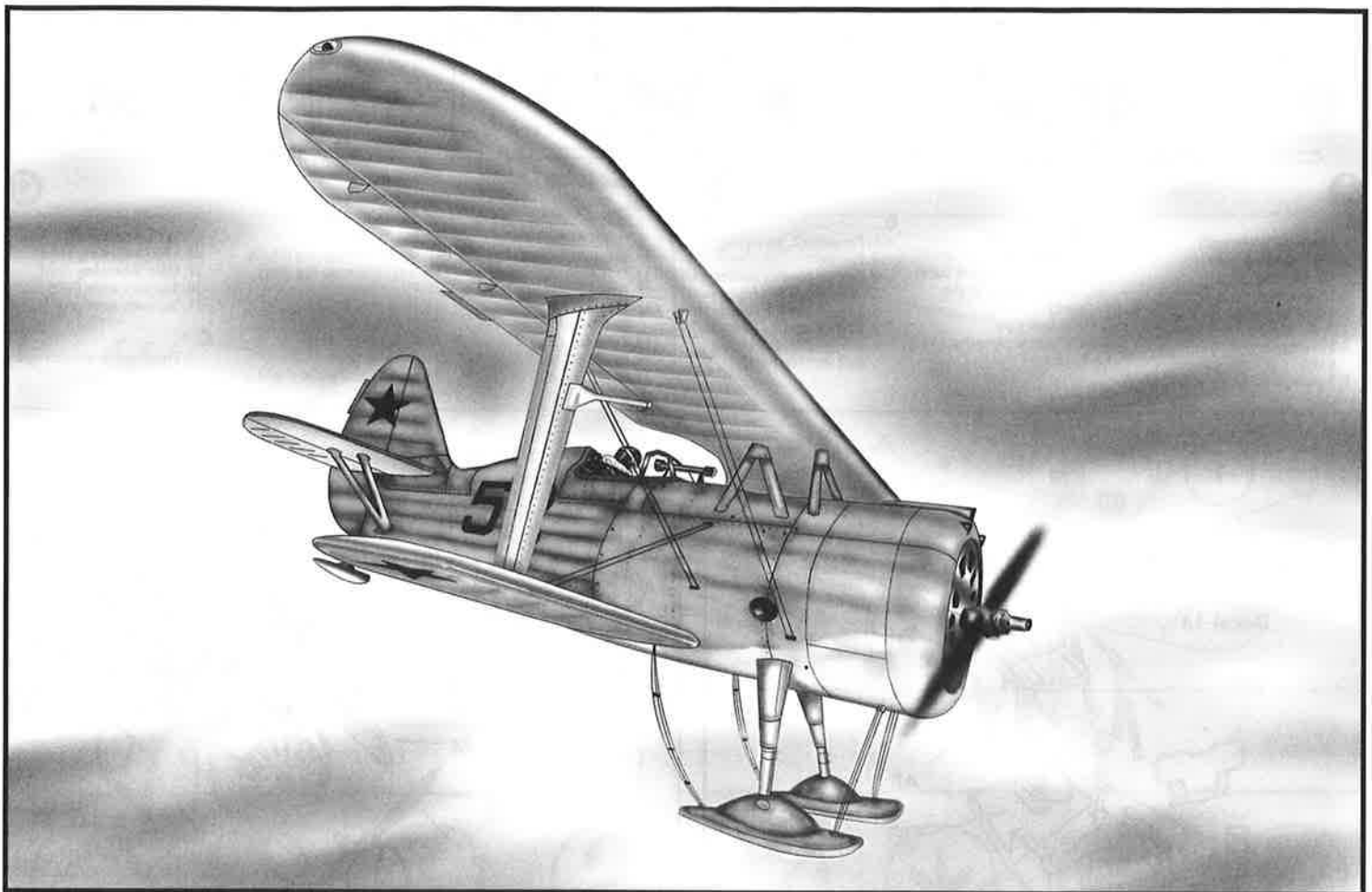

The fighter biplane reached its ultimate development in the form of the Soviet I-15 bis. This legendary aircraft was developed by the N. Polikarpov Design Bureau and production commenced in 1938. By the end of the following year, 2,408 aircraft had been delivered in two modifications and a two seater version.

The I-15 bis saw action in Spain, China, Mongolia and the Soviet-Finnish conflict, as well as during the opening stages of the Soviet-German War in 1941, when it was deployed both as a fighter and in the ground attack role.

V. Lavrinenkov and V. Kubarev (46 confirmed

victories each during the Soviet-German War) and L. Shestakov (39 confirmed combat victories during the Spanish Civil War) are among the many accomplished pilots who flew the I-15 bis into air combat. Many other aces began their combat careers in this aircraft.

In addition to distinguished service career in the Soviet Air Force, the I-15 bis was used by the Finnish, Spanish and Chinese Air Force, and captured aircraft entered service with the Luftwaffe.

Technical and tactical specifications I-15 bis:

Length - 6.275 m	Span - 10.20 m	Start weight - 1730 kg
Max. speed - 379 km/h	Ceiling - 9,300 m	Range - 520 km
Armament:	4x 7.62mm PV-1 machine guns; 4x25 kg or 4x32 kg bombs.	

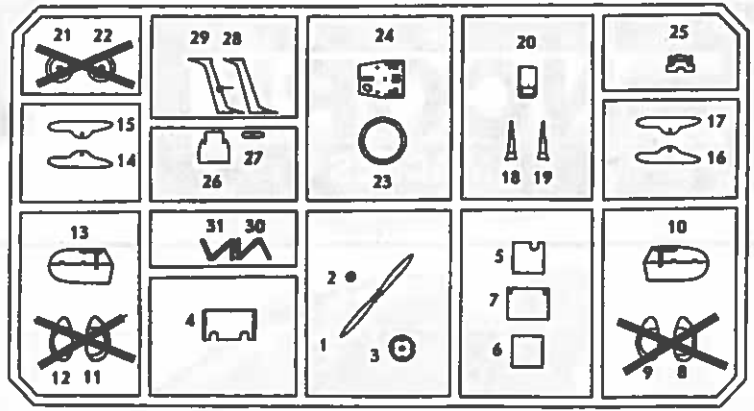
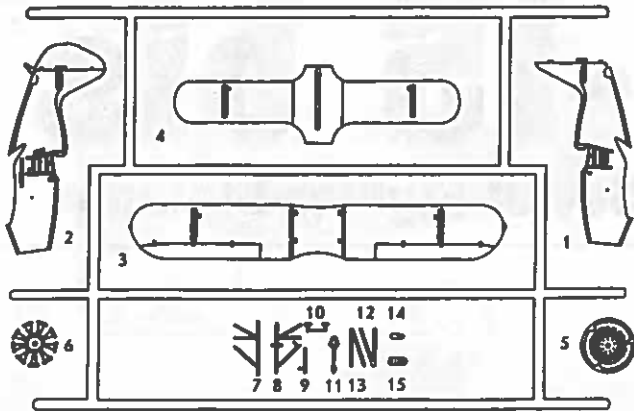

- A**
1. Fuselage (right half)
 2. Fuselage (left half)
 3. Upper wing
 4. Upper wing
 5. Front engine
 6. M-25 engine
 7. Fuselage framework (right part)
 8. Fuselage framework (left part)

9. Gunsight
10. Rudder pedals
11. Control stick
12. Tailplane strut (left part)
13. Tailplane strut (right part)
14. Exhaust pipe
15. Oil cooler pipestrut (left)

- B**
1. Propeller
 2. Stop Ring
 3. Spinner
 4. Engine cowling (under part)
 5. Engine cowling (right part)
 6. Engine cowling (upper part)
 7. Engine cowling (left part)
 8. Undercarriage cowling (left outside part)

9. Undercarriage cowling (right outside part)
10. Tailplane (right)
11. Undercarriage cowling (right inside part)
12. Undercarriage cowling (left inside part)
13. Tailplane (left)
14. Ski (right half)
15. Ski (left half)
16. Ski (right half)
17. Ski (left half)
18. Undercarriage leg (right)
19. Undercarriage leg (left)
20. Pilot's seat
21. Main wheel
22. Main wheel
23. Exhaust collector
24. Cockpit floor
25. Instrument panel (right)

- C**
1. Three piece windscreen
 26. Armour plate
 27. Tail ski (left part)
 28. Main interwing strut
 29. Main interwing strut
 30. Support strut (left)
 31. Support strut (right)

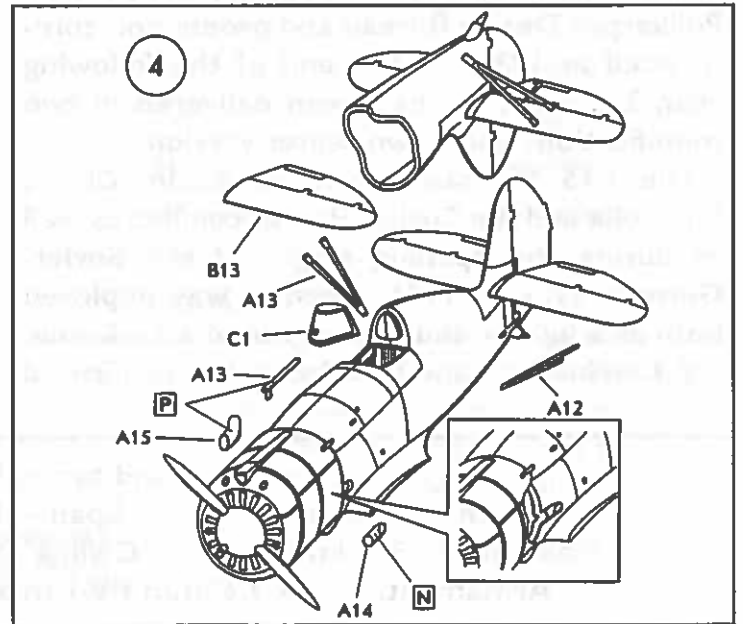
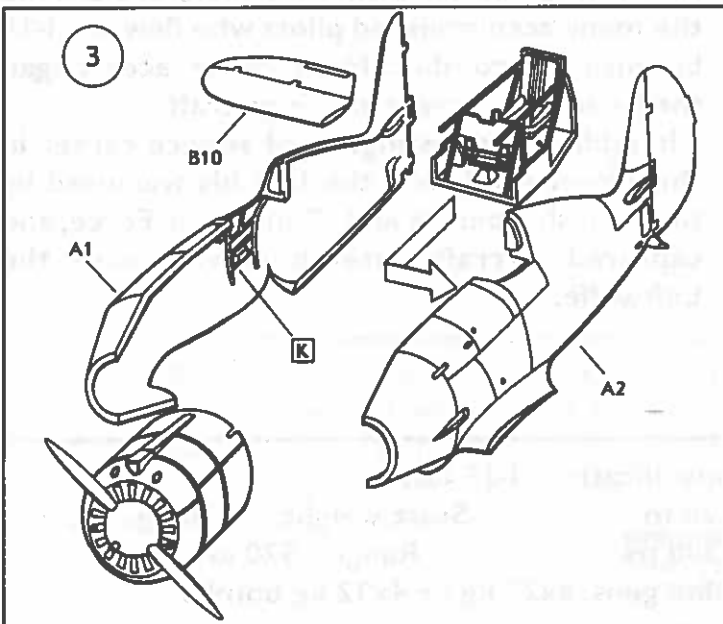
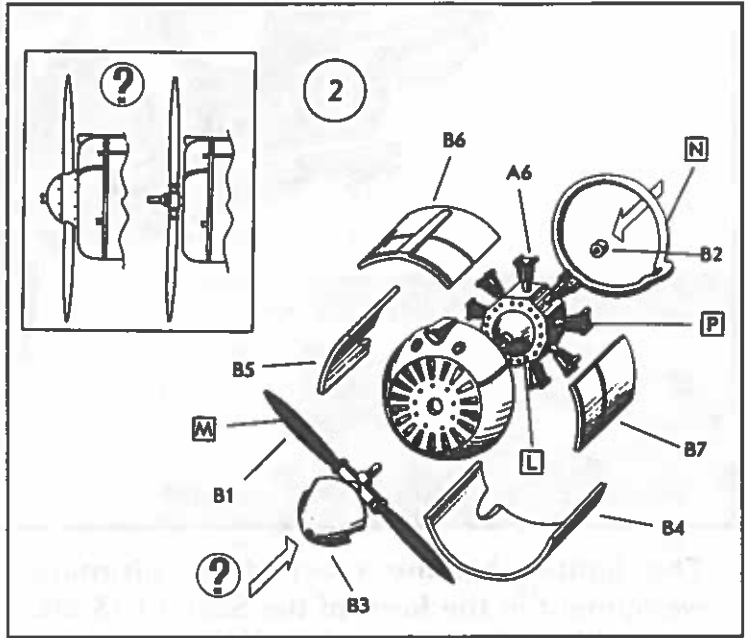
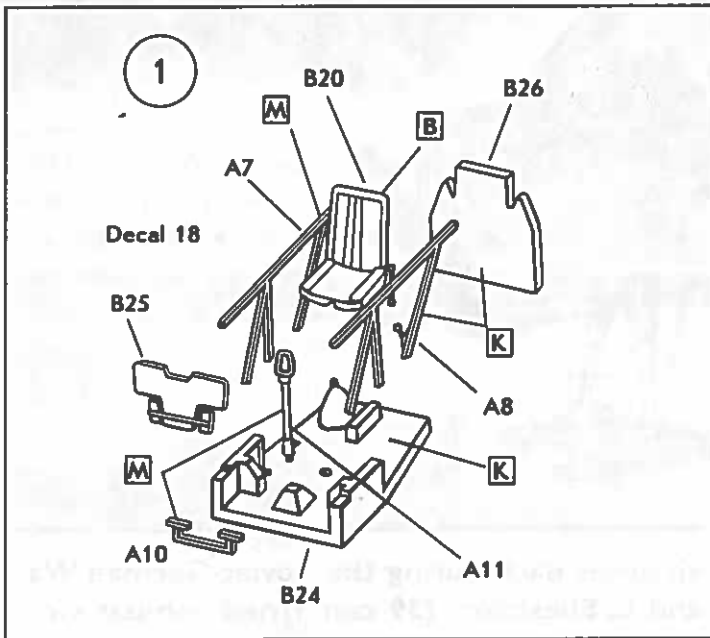

5

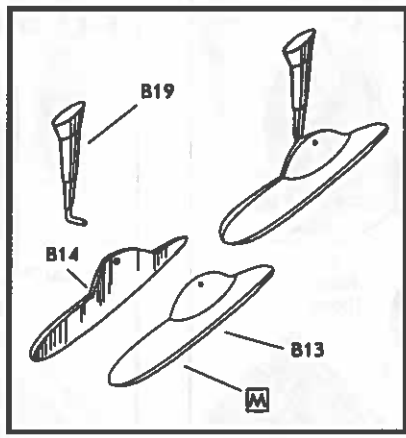

6

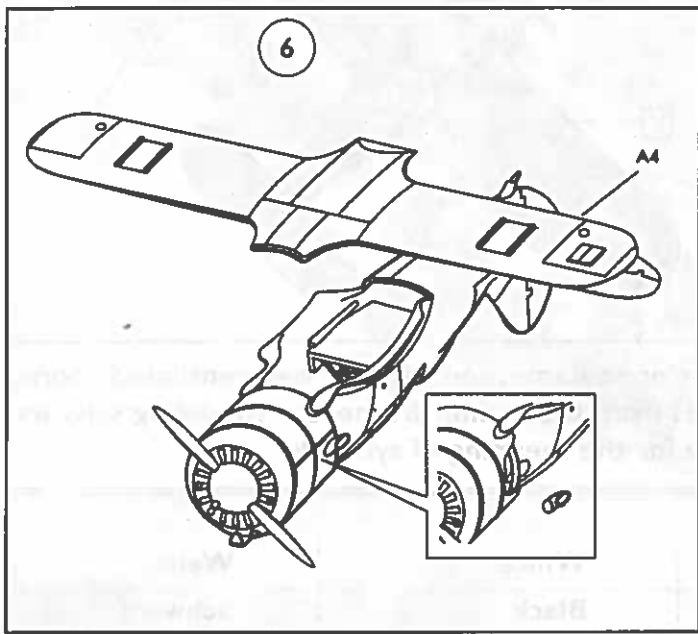

7

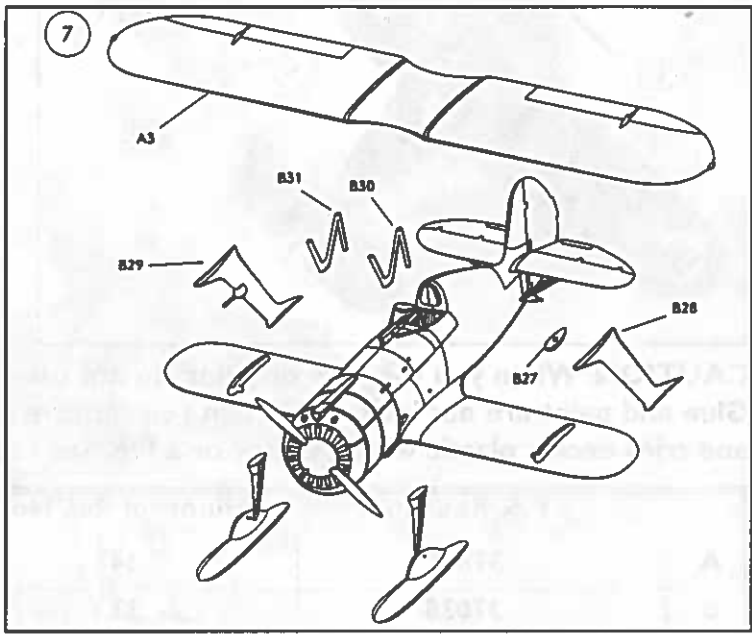

Cement



Remove



Open Hole



Optional



Do Not Cement



Bend



Fill Hole



Make 2 Pcs

I-15 bis captured by the Finns

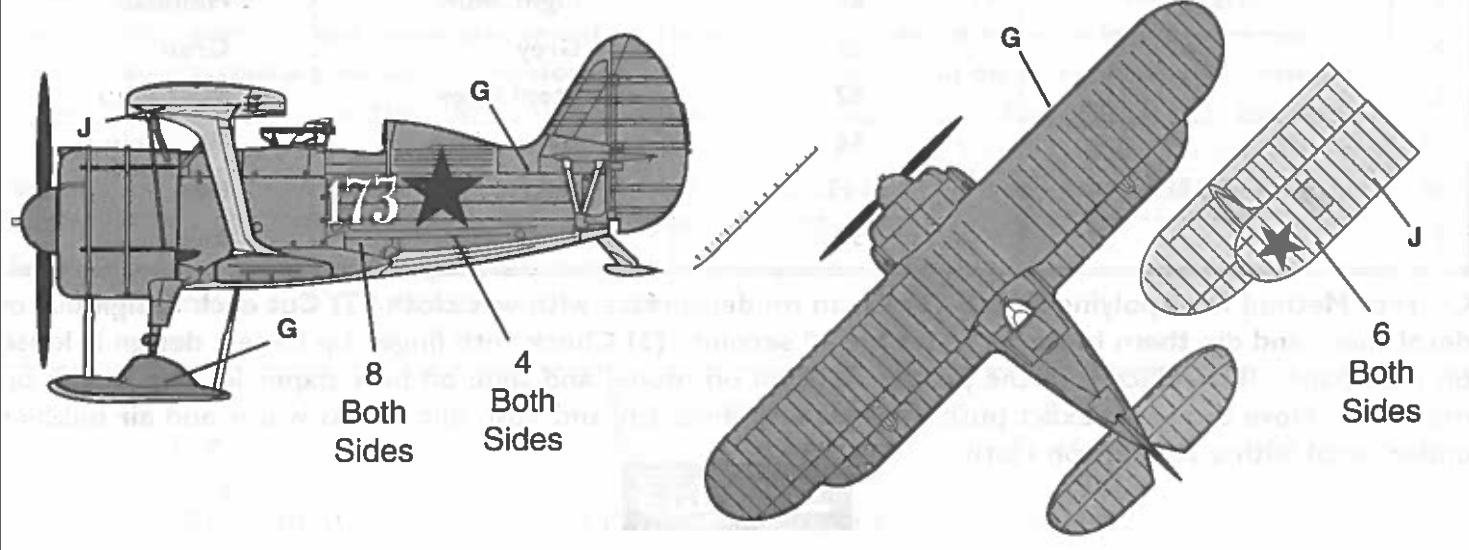

I-15 bis Finnish Air Force 1945

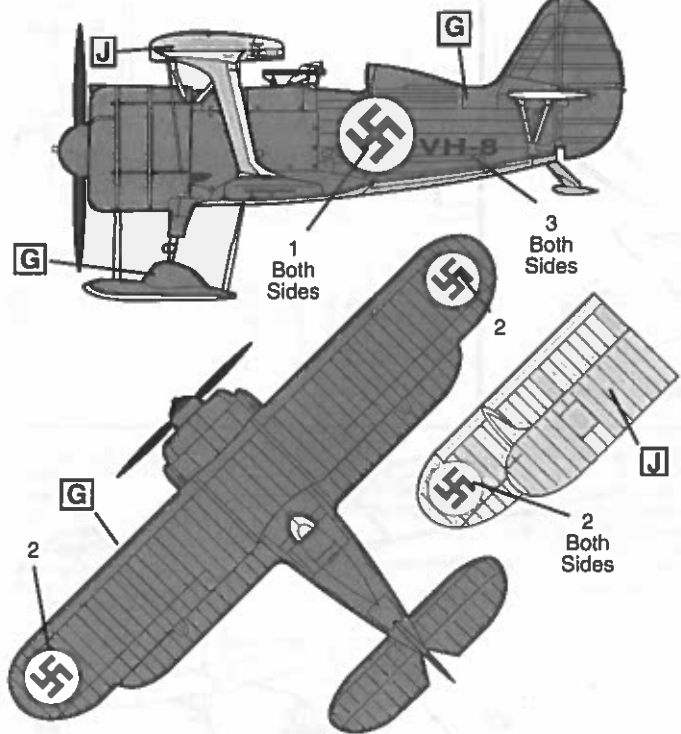

I-15 bis Winter Camouflage

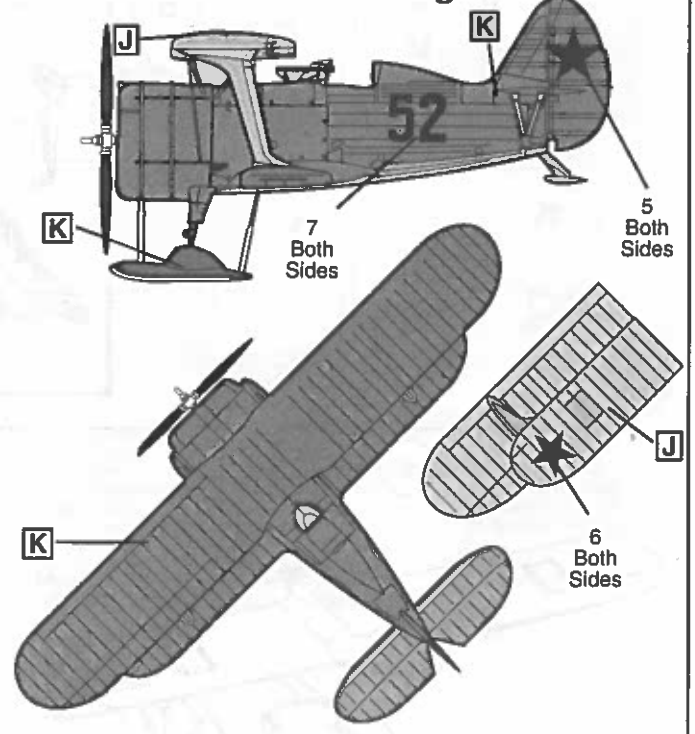

CAUTION: When you use glue or paint, do not use near open flame, and use in a well ventilated room. Glue and paint are not included. When you remove parts from the runner frame, use modeling scissors and trim excess plastic with a cutter or a file. See inside for the meaning of symbols.

	F.S. Ref. No.	Humbrol Ref. No.		
A	37875	34	White	Weiss
B	37038	33	Black	Schwarz
C	31102	174	Red	Rot
D	33618	99	Yellow	Gelb
E	34096	114	Russian Green	Russisch grün
F	35190	115	Russian Blue	Russisch blau
G	34087	155	Olive Drab	Olivgrün
H		92	Grey Green	Graugrün
J	35526	65	Light Blue	Hellblau
K	36622	28	Grey	Grau
L		87	Steel Grey	Stahlgrau
M		56	Aluminium	Aluminium
N	30117	113	Rust	Rost
P		53	Gunmetal	Eisen

Correct Method for Applying Decals (1) Clean model surface with wet cloth. (2) Cut each design out of decal sheet and dip them in warm water for 20 seconds. (3) Check with finger tip to test design is loose on base paper. If so, place it in the proper position on model and slide off base paper leaving design on model. (4) Move design to exact position with wet finger tip, and push out excess water and air bubbles under decal with a soft cotton cloth.



1115 Crowley Drive • Carrollton, Texas • 75011-5010 USA

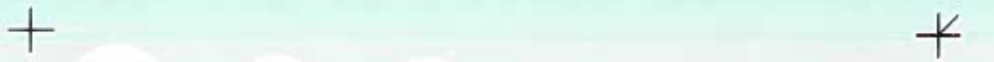

VH-8

3

VH-8



1

2



5



4



6



52

7

52

173

8

173

No.1024

