

Fairey Battle - For Poland

Instructions

FR

Le Fairey Battle est développé en réponse à la spécification P37/32 de 1933. Le premier vol du prototype a lieu le 10 mars 1936. Les Battle, assemblés par Fairey (1164) et par Austin Motors (1032), sont produits en version bombardier, mais aussi en appareil d'entraînement (T) et en remorqueur de cible (TT). Le Fairey Battle est largement utilisé par la RAF mais aussi par l'Australie (367), la Belgique (16), le Canada (754), l'Irlande, la Grèce (11), l'Inde (2), la Nouvelle Zélande (2), l'Afrique du Sud (179), la Rhodésie (25), la Turquie (30). Il est également employé par l'Armée de l'Air polonaise au Royaume Uni.

La RAF reçoit ses premiers Battle en 1937, plus de 40 squadrons utilisent l'appareil. A la déclaration de la guerre, 10 squadrons de l'AASF prennent position en Champagne. Le 10 mai 1940, sur 32 Battle en action, 13 sont abattus par la FLAK, les autres étant endommagés. Le lendemain, les huit appareils qui bombardent les Allemands au Luxembourg sont tous abattus. Le 15 mai, les Battle passent au bombardement de nuit. En une semaine de combat, les bombardiers de l'AASF ont eu 50 % de pertes. Pendant la campagne de France, il semble que 137 Battle aient été perdus.

La RAF entreprend, à partir du 21 juillet 1940, une campagne de bombardement de nuit sur le continent. Les Sqn de Battle n°12, 142, 103 et 150 participent à ces opérations, ainsi que les Sqn polonais 300 et 301 à partir d'août, jusqu'en octobre 1940.

La Pologne est intéressée par le Battle, une commande de 100 appareils est passée en juillet 1939, mais les 25 Battle envoyés trop tard en septembre 1939 sont détournés en Turquie. Plusieurs Squadrons de la Polish Air Force au Royaume Uni utilisent le Battle à partir d'août 1940, soit comme bombardier (300, 301) soit comme appareil d'entraînement (302, 303, 308, 317). Le Sqn 300 (Mazovie) passe sur Wellington à partir de novembre 1940.

Le Canada prend en compte à partir de 1939 740 Battle dont 632 bombardiers. La plupart des Battle canadiens servent à l'entraînement dans les Bombing and Gunnery Schools. Ces appareils sont souvent peints suivant un schéma très spectaculaire, le dessous étant en jaune et le dessus restant camouflé mais avec de grands espaces jaunes bien visibles.

Les Battle britanniques, belges, polonais, grecs et sud-africains (en Afrique orientale) sont employés en combat lors de la Seconde guerre mondiale.

Spécifications (bombardier) : bombardier monomoteur triplace (biplace pour les Belges), moteur Merlin I, II, ou III, délivrant 880 HP au décollage. Vitesse maximum 394 km/h à 6 000 m, plafond 7 620 m, envergure 16,46 m, longueur 12,9 m. Armement offensif : 4 bombes de 250 Lb en interne sous aile, deux bombes de 250 Lb en extérieur. Armement défensif : une mitrailleuse de 7,62 cm dans l'aile droite, une mitrailleuse Vickers de 7,62 cm en arrière du cockpit.

EN

The 1933 Air Ministry Specification P37/32 sought a replacement for the biplane Hawker Hart then in service. Fairey's design was selected for production and named Battle. March 10, 1936 saw the prototype's maiden flight. Battles were assembled by Fairey (1,164) and Austin Motors (1,032). The majority of Battles were produced as bombers but also as trainers (T), and as target tugs (TT). Battles were flown by RAF and the air forces of Australia (367), Belgium (16), Canada (754), Ireland, Greece (11), India (2), New Zealand (2), South Africa (179), Rhodesia (25), Turkey (30). Also, members of the Polish Air Force in the UK initially flew the Battle with Nos. 300, 301, 304, and 305 (Pol) Sqn, RAF.

The RAF received its first Battle in 1937. More than 40 squadrons flew the type in service. When war was declared, ten squadrons belonging to the AASF took up positions in Champagne. On May 10, 1940, the first bombing raids revealed the Battle's extreme vulnerability when 13 of 32 committed to action were shot down. The next day, eight Battles bombing the Germans in Luxembourg were all shot down. On 15 May, the Battles switched to night bombing. In one week of fighting the AASF's Bombers squadrons averaged 50% losses, and during the brief French campaign 137 Battles were lost. Beginning on the night of 21-22 July 1940, the RAF commenced a night bombing campaign on the Continent. Battle-equipped Squadron Nos. 12, 142, 103 and 150 took part in these operations, and Nos. 300 and 301 (Pol) Sqn joined the fray from 14 August, until October 1940.

Poland was interested in the Battle before the war, and placed an order for 100 aircraft in July 1939, 25 Battles were shipped in September 1939 but finally were sent to Turkey. However, several Squadrons of the Polish Air Force in the UK used the Battle from August 1940, either as a bomber (300, 301) or as a trainer (302, 303, 308, 317). Sqn 300 (Mazovia) left the Battle for the Wellington on November 1940.

From 1939 onwards, Canada took into account 740 Battles, including 632 bombers. Most of the Canadian Battles were assigned local Serials, and were used for training in the Bombing and Gunnery Schools. These aircraft were often painted in a spectacular pattern, the underside being yellow and the top remaining camouflaged but with large yellow spaces clearly visible. British, Belgian, Polish, Greek and South African (in East Africa) Battles were used in combat during WWII.

Specifications (bomber): single-engine, three-seater bomber, Merlin I, II, or III engine, delivering 880 HP at take-off. Maximum speed 394 km/h at 6,000 m, ceiling 7,620 m, wingspan 16.46 m, length 12.9 m. Offensive armament: four 250 Lb bombs internally under wing, two 250 Lb bombs externally. Defensive armament: one 7.62 mm machine gun in the right wing, one 7.62 mm Vickers machine gun in the rear cockpit.

Tous nos remerciements aux personnes qui ont fourni des informations / Thanks to all persons who provided informations.

Parts List

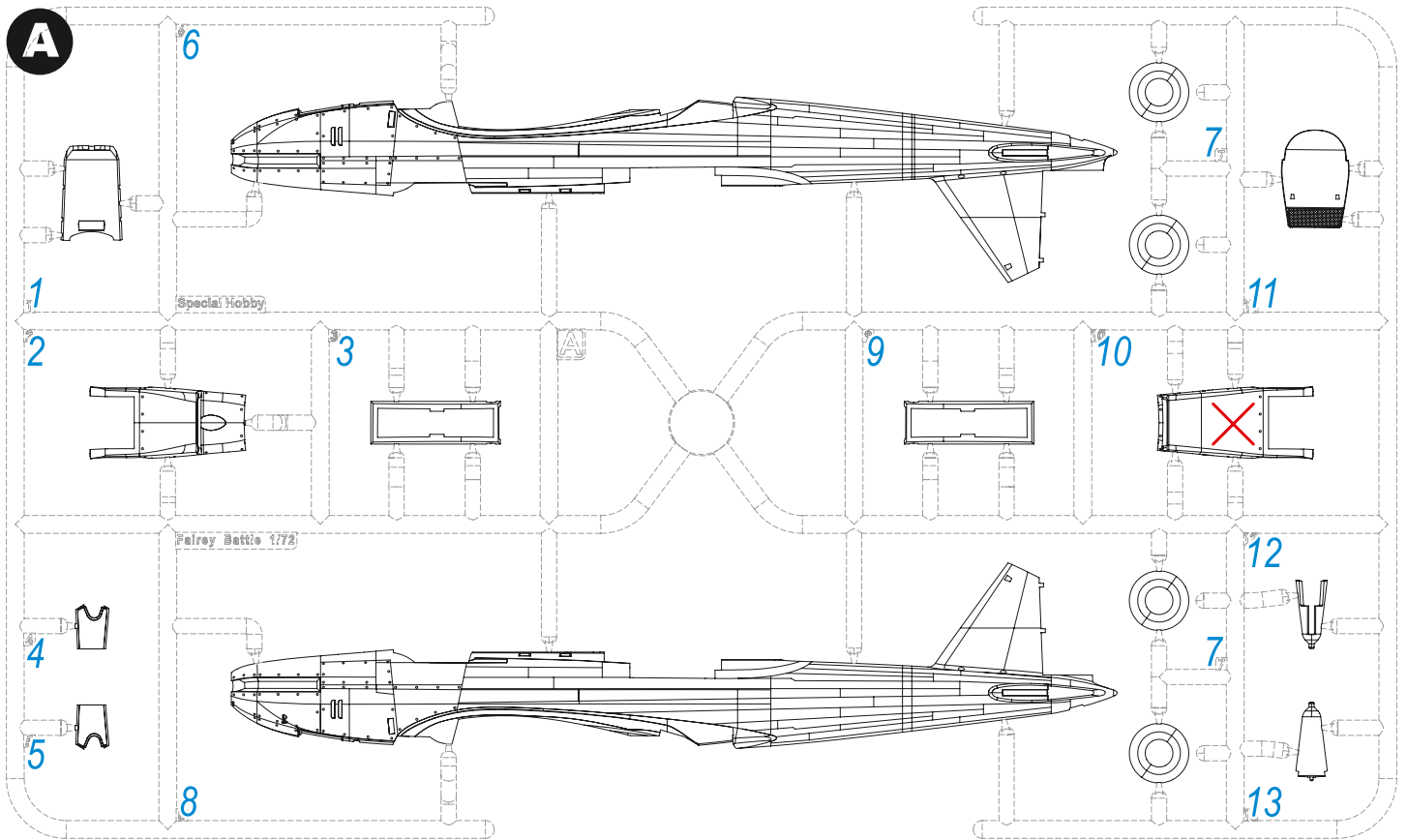

✗ = Not used

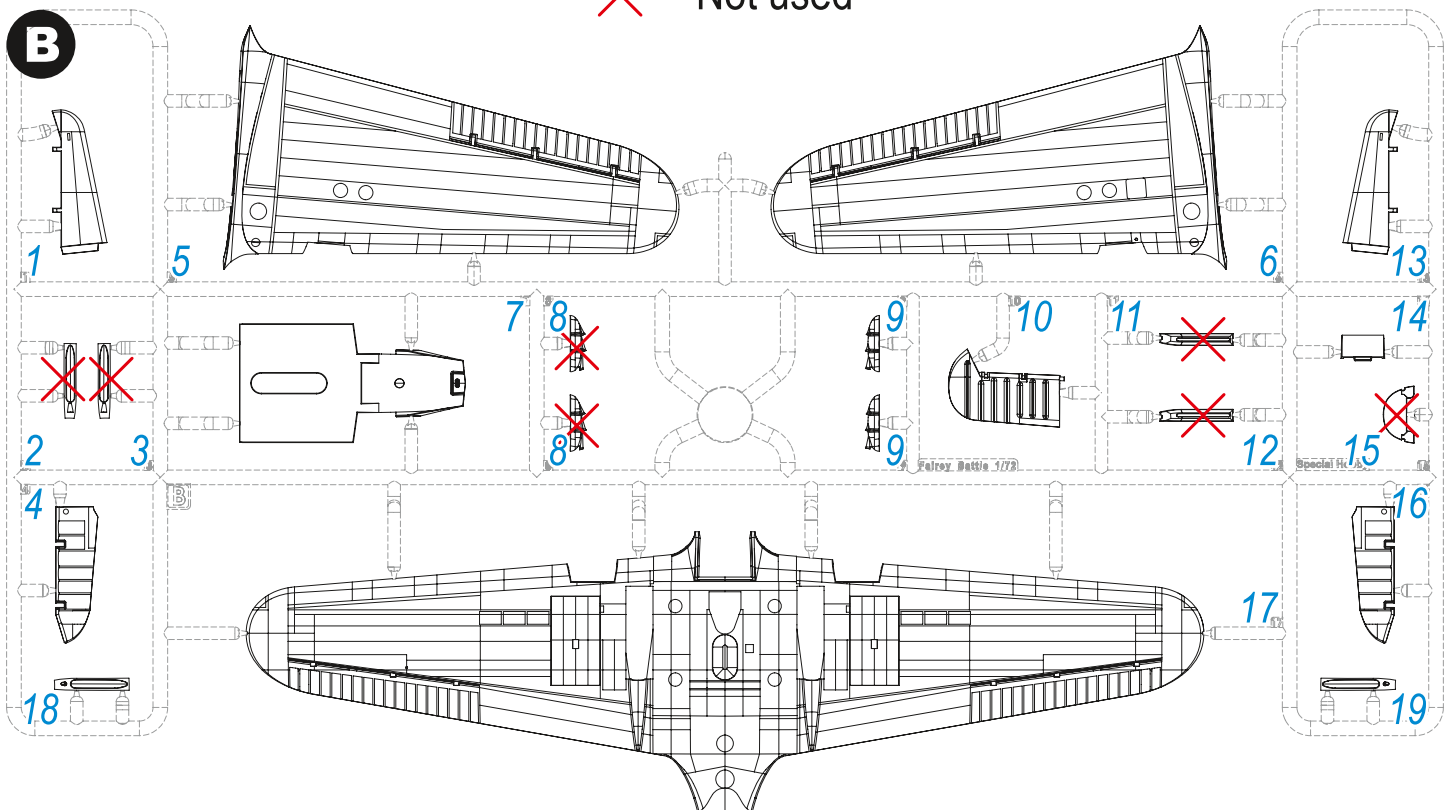

MOŽNOST VOLBY
OPTIONAL
NACH BELIEBEN
OPTION



POUŽÍŤ KYANOAKRYLÁTOVÉ LEPIDLO
INSTANT CYANOACRYLATE GLUE
ZYANOAKRYLÁTKLEBER
ADHÉSIF CYANOACRYLAT

SYMBOLS



OHNOUT
BEND
BIEGEN
COURBER



ZHOTOVIT NOVĚ
SCRATCH BUILD
FERTIGSTELLEN
ACHEVER



ŘEZAT/VRTAT
CUT OFF/DRILL
ENTFERNEN
DETACHER



NATŘÍT
COLOUR
FARBEN
PEINDRE

2

FR0047 Fairey Battle

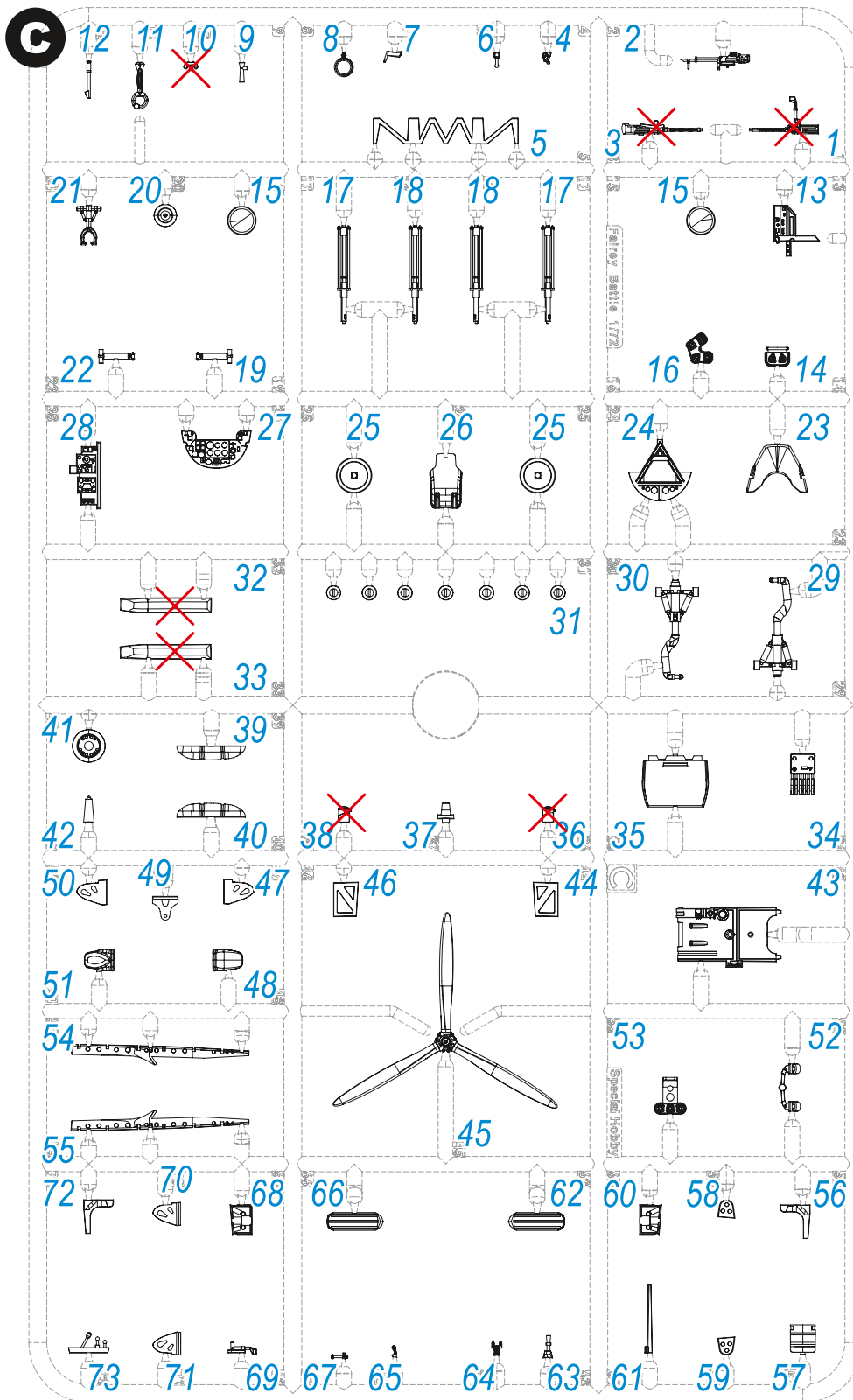

X = Not used

Clear Parts

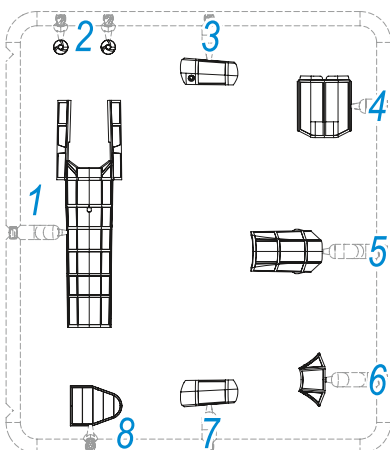

GUNZE Colour No.

(A)	Vert Gris / Grey Green (interior)	H58/C27
(B)	Noir / Black	H12/C33
(C)	Noir De Pneu / Tire Black	H77/C137
(D)	Alu / Aluminium	H8/C8
(E)	Métal Carbonisé / Burnt Iron	H76/C61
(F)	Fer Foncé / Dark Iron	H28/C78
(G)	Rouge Transparent / Clear Red	H90/C47
(H)	Vert Transparent / Clear Green	H94/C138
(I)	Cuir / Leather	H47/C41
(J)	Jaune / Yellow	H329/C329

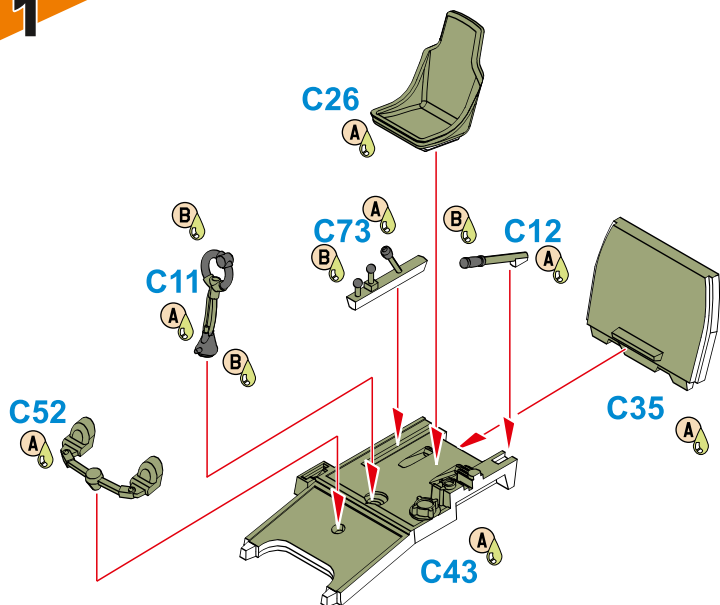
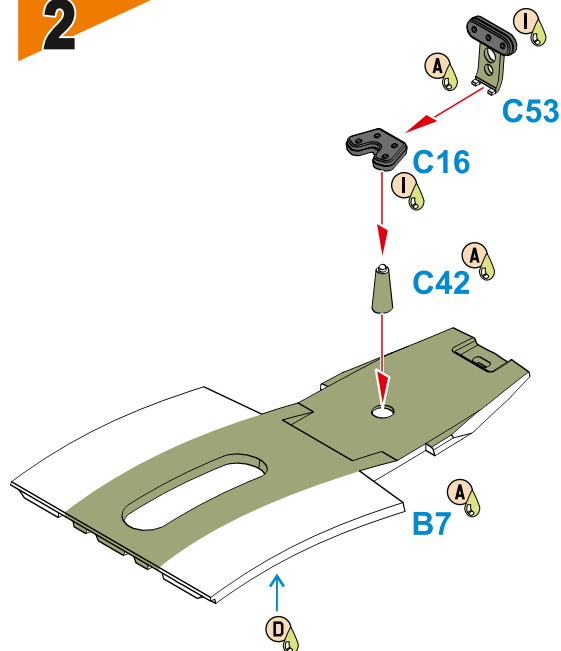
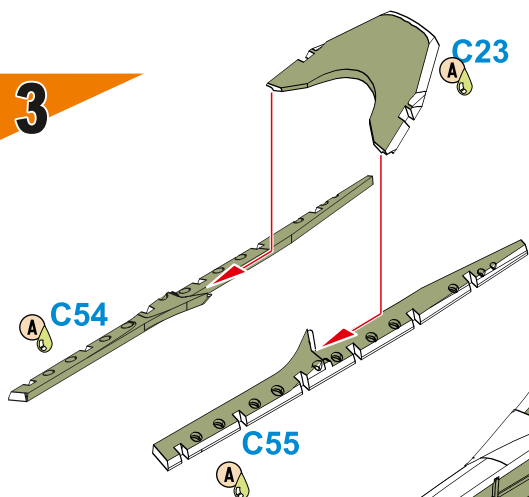
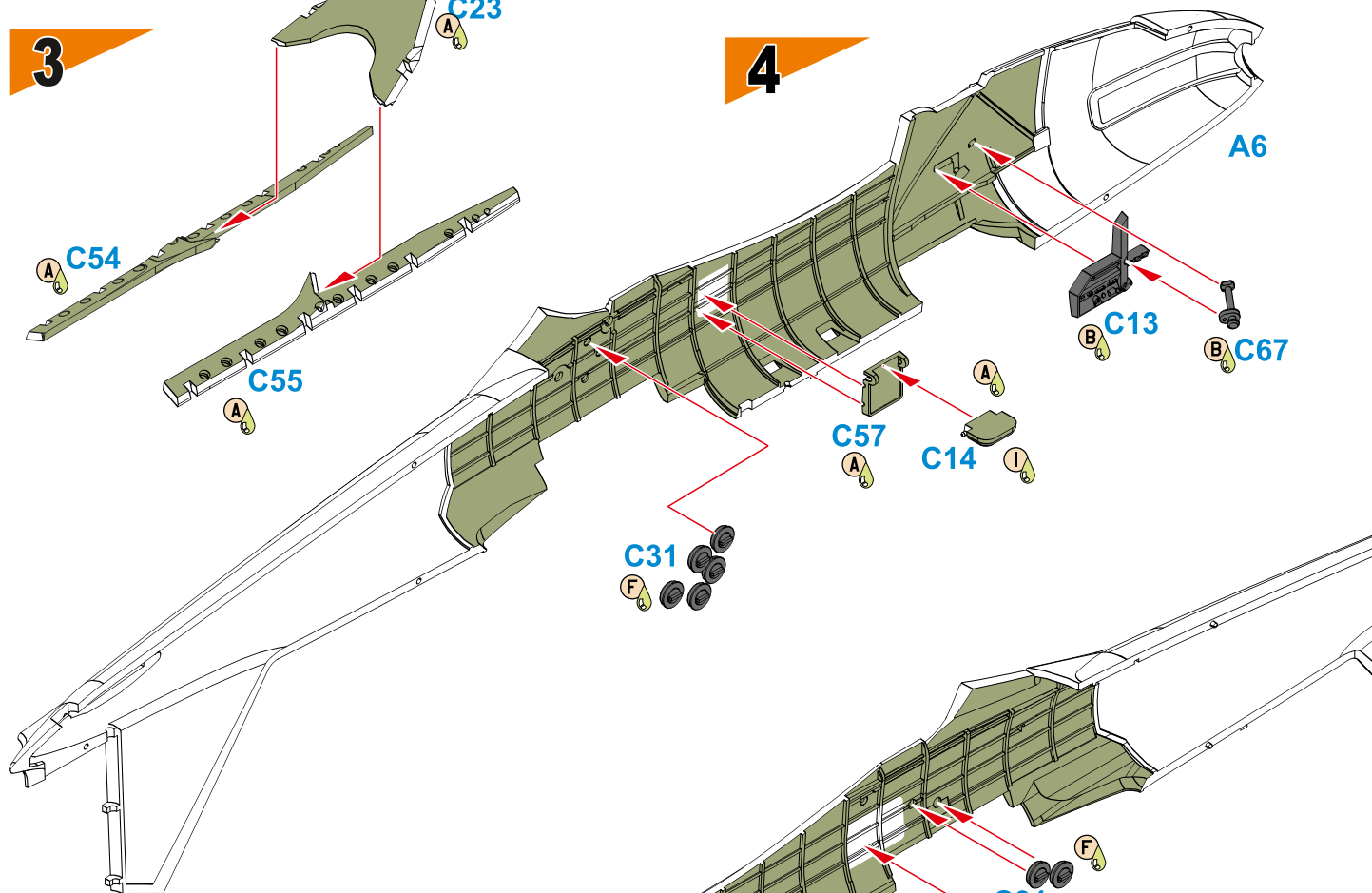
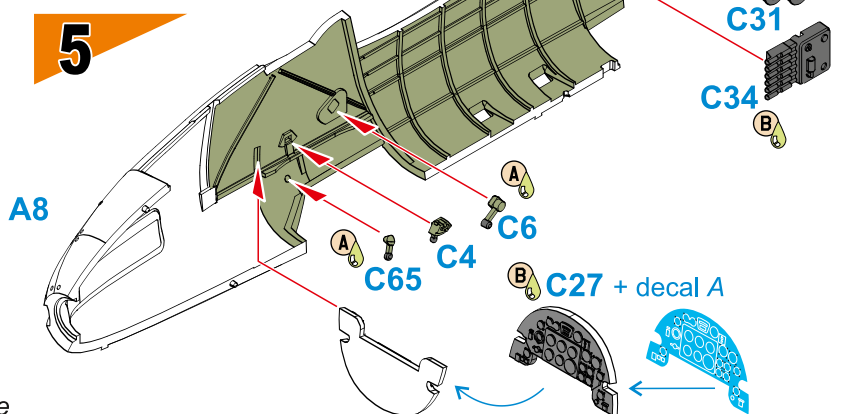
1**2****3****4****5****4**

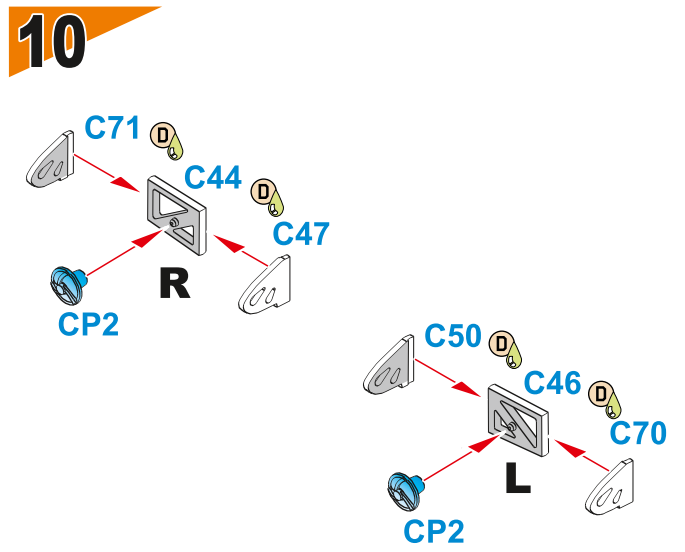
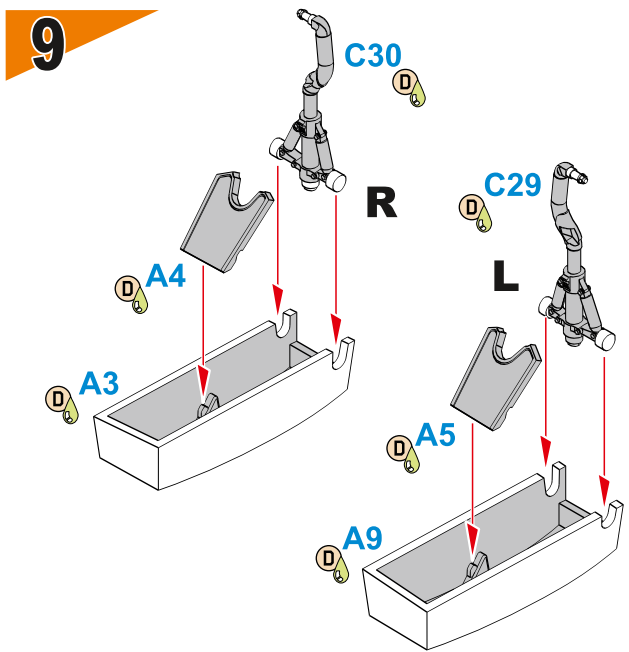
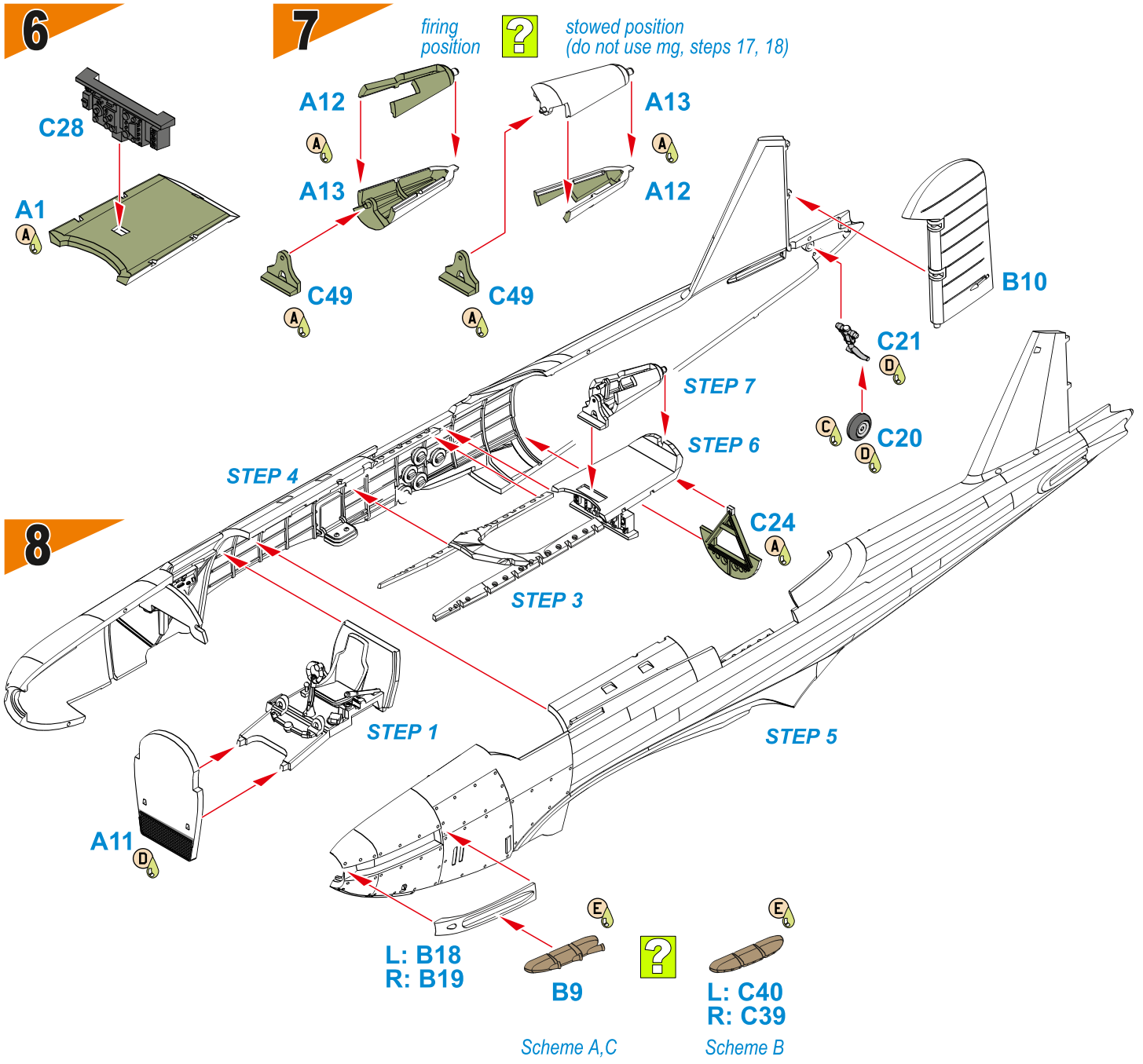

11

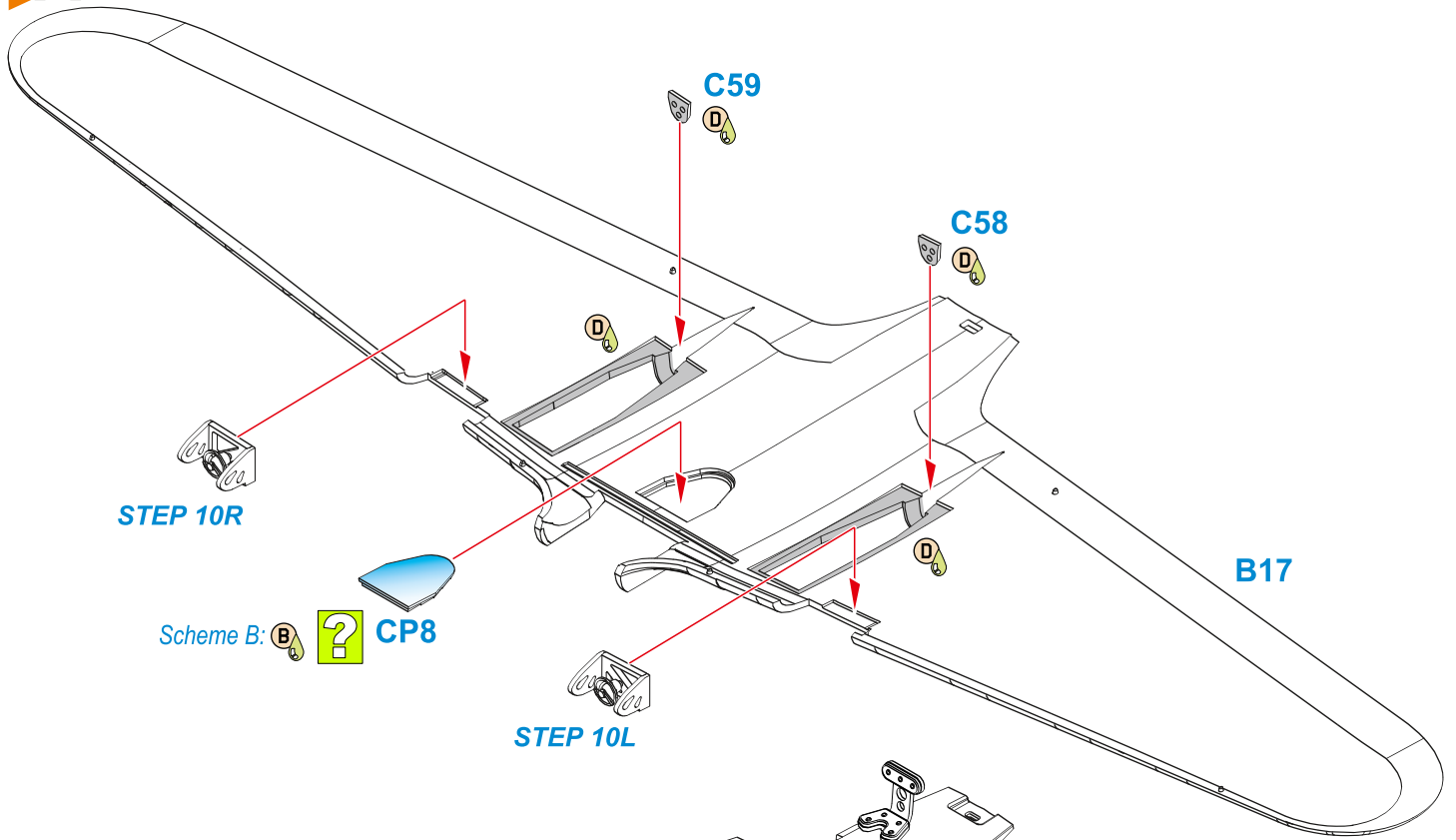

12

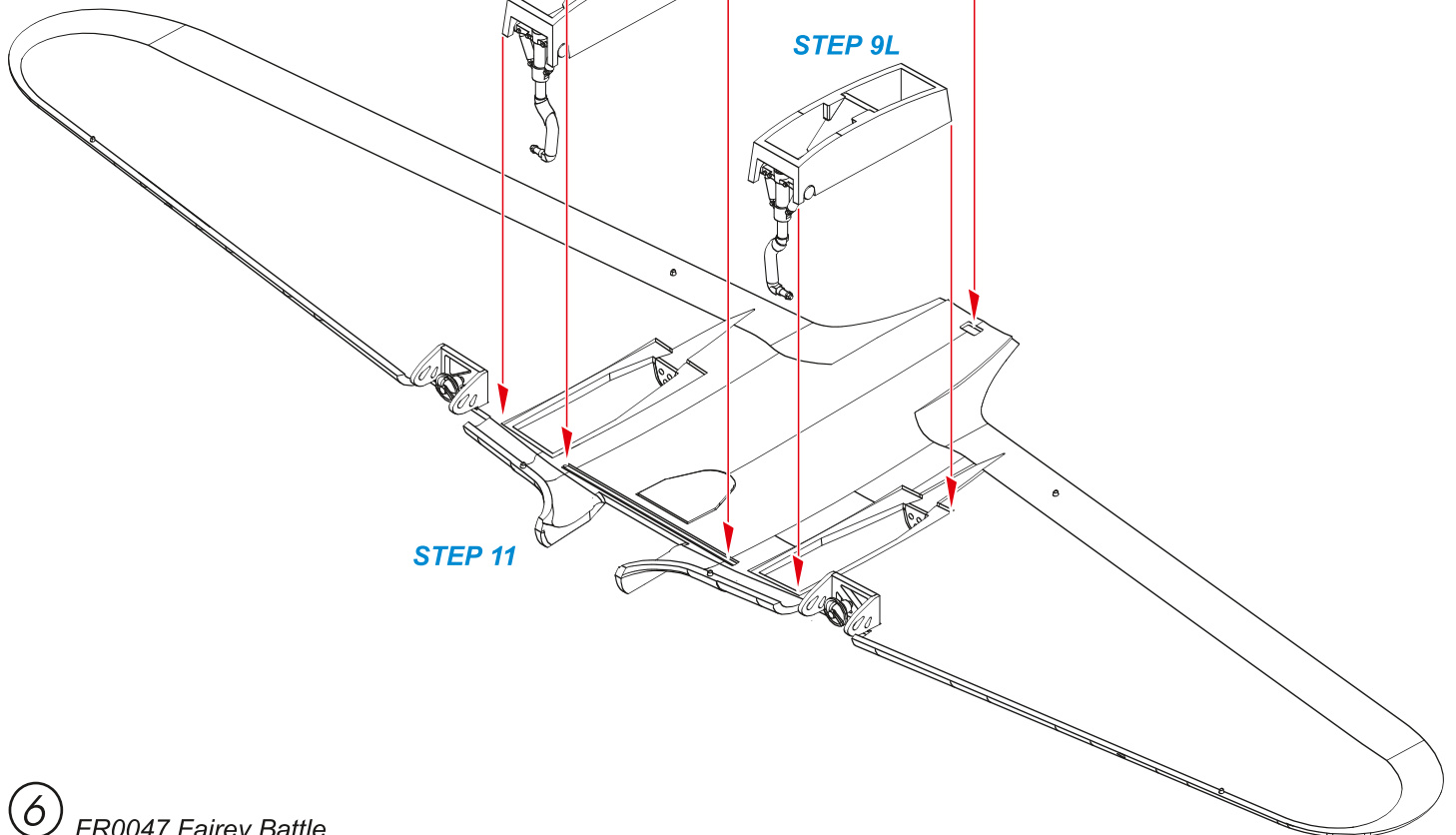

13

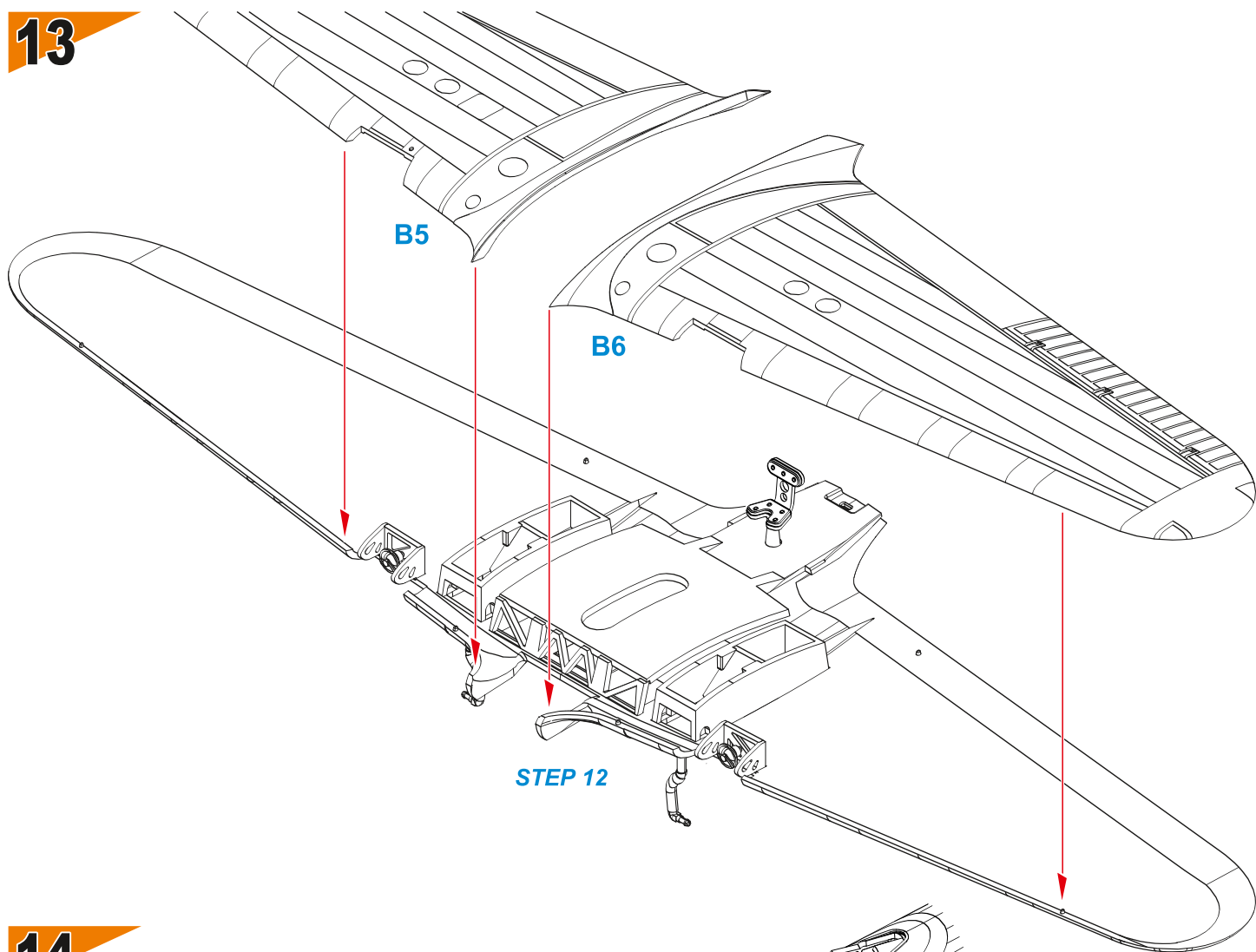

14

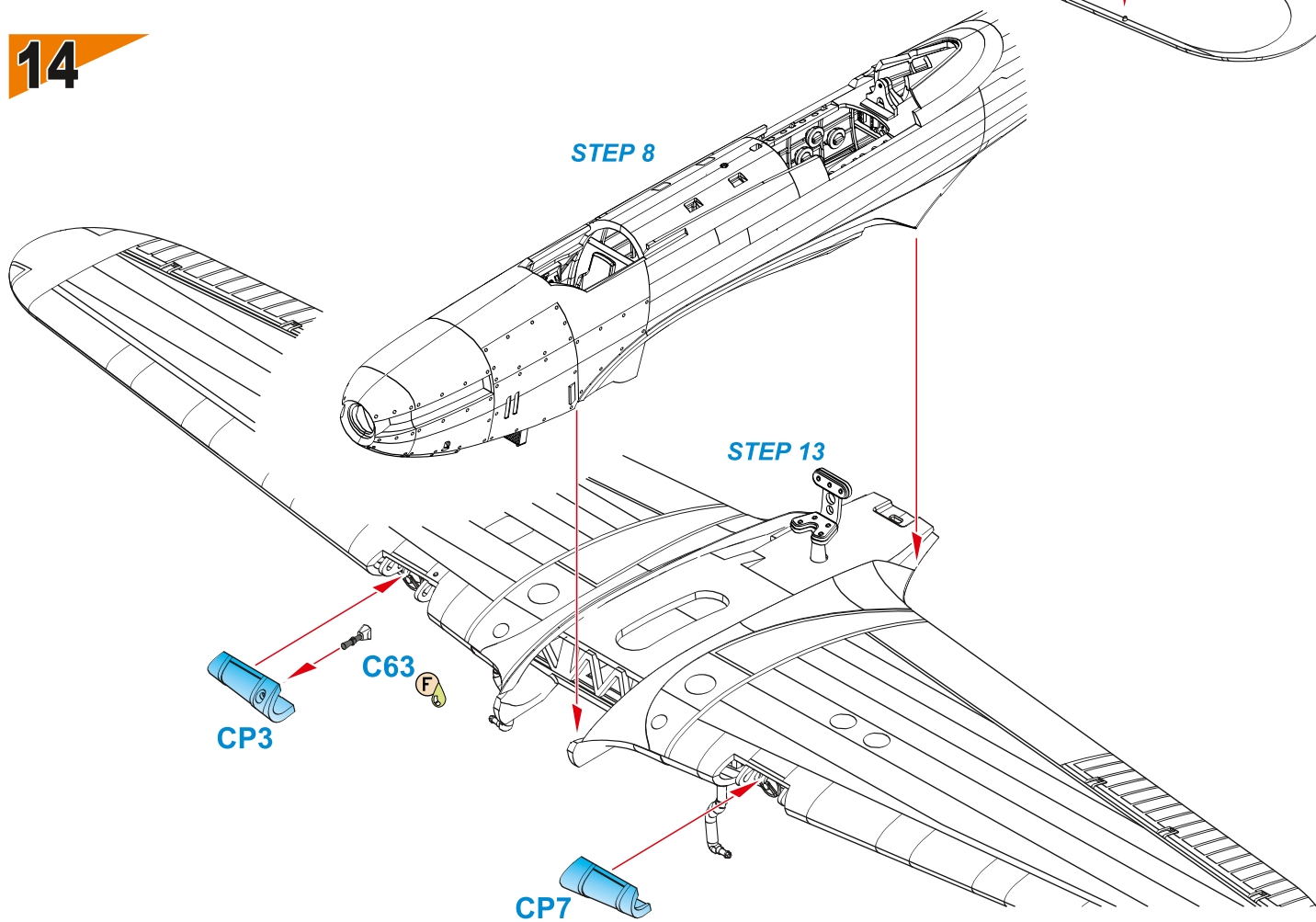

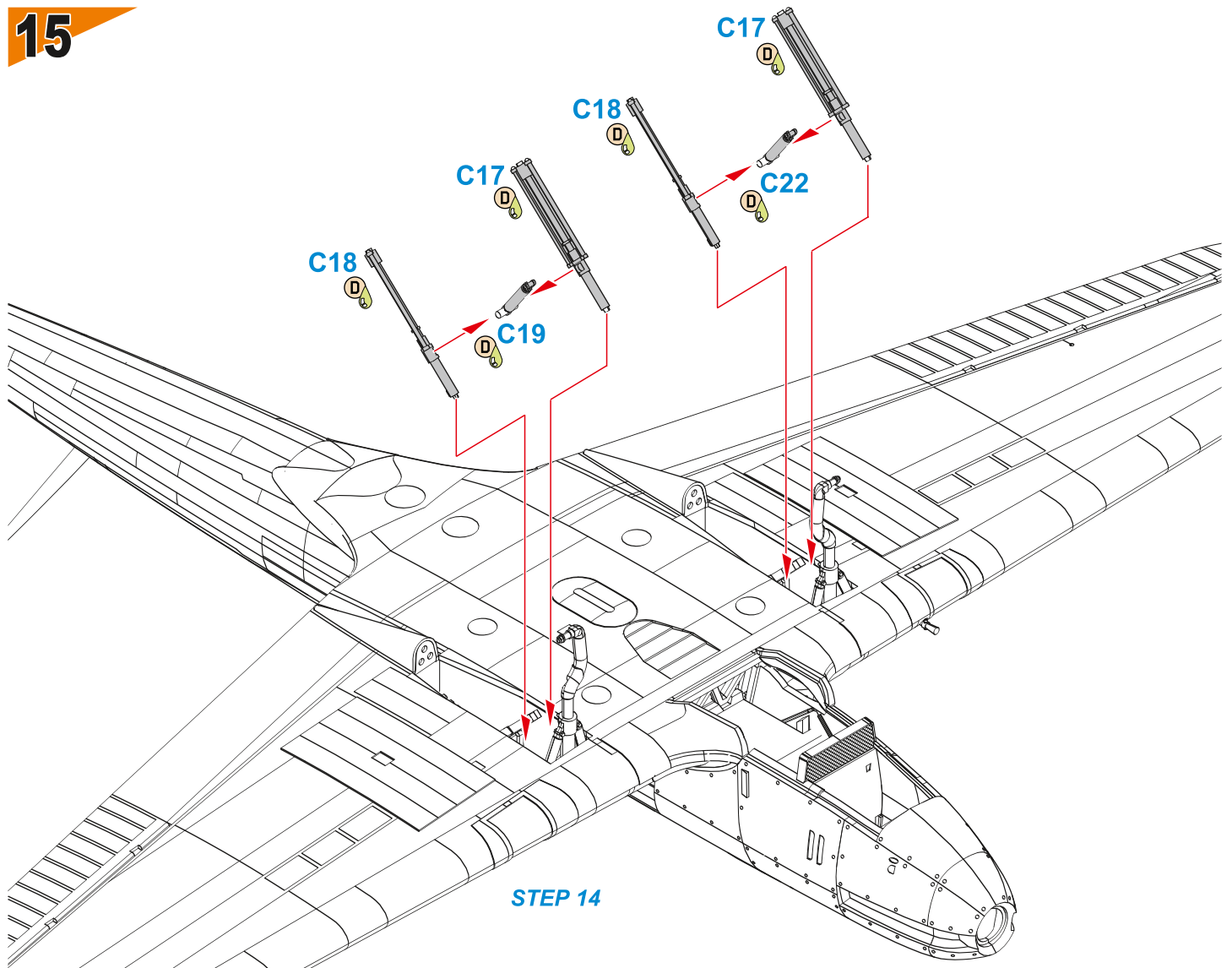

STEP 14

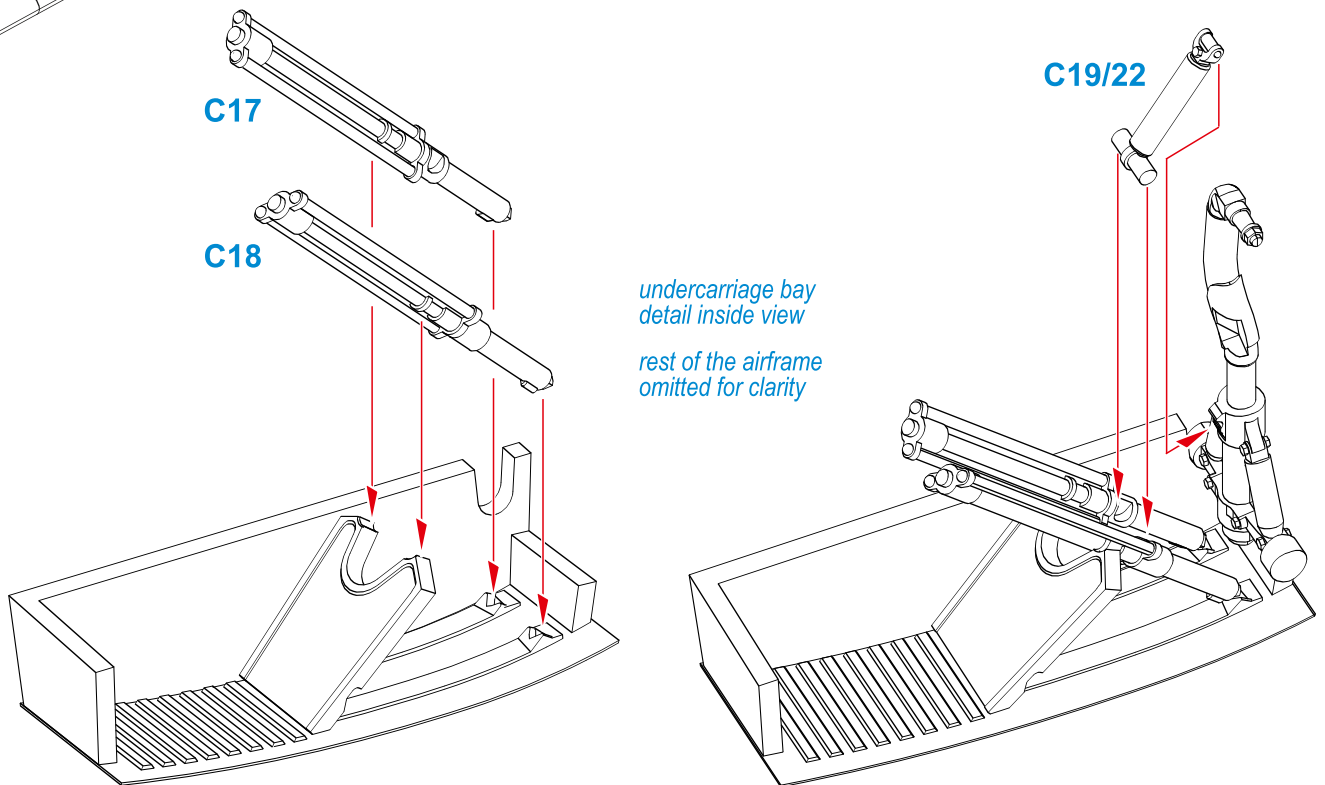

16

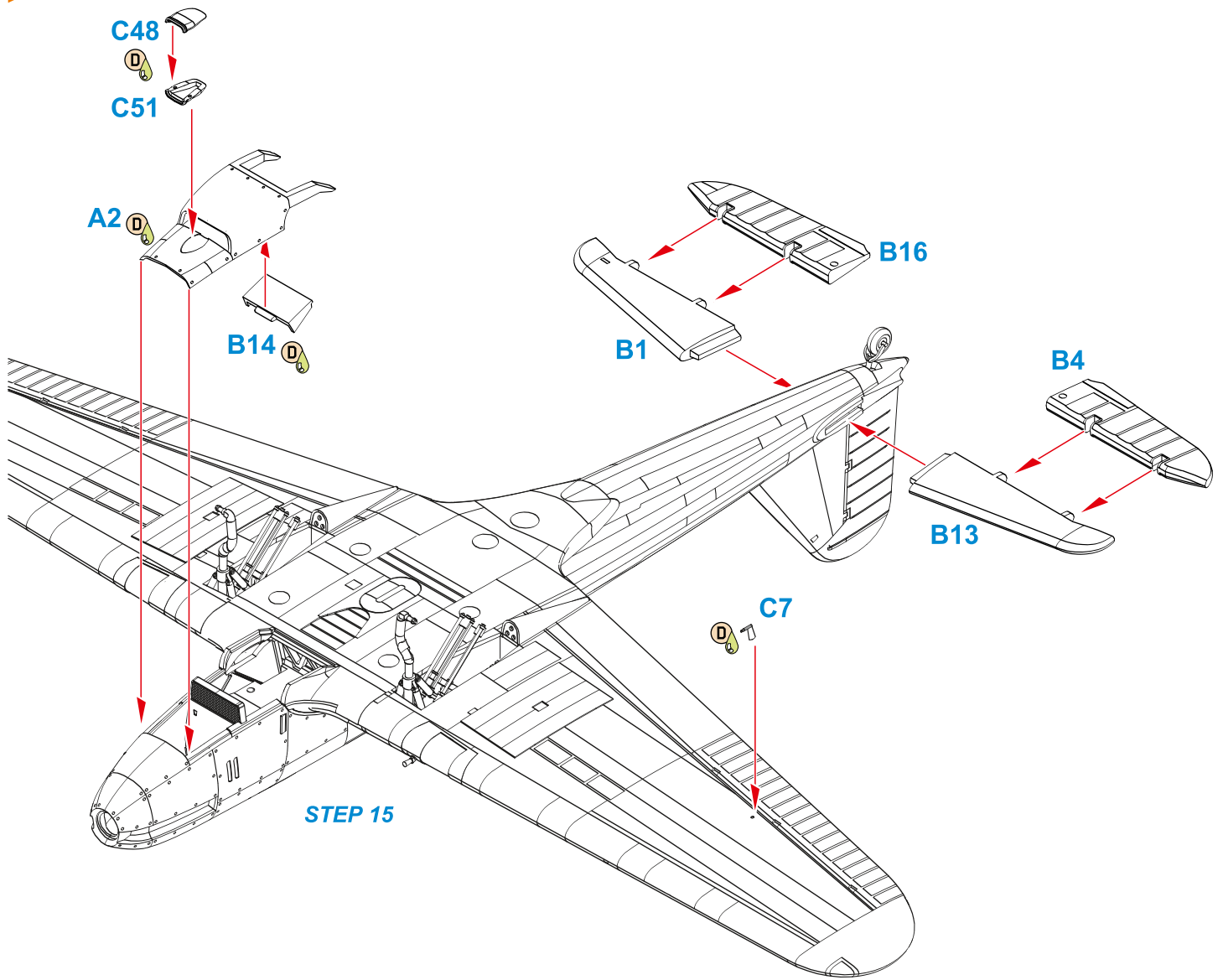

17

? Scheme A,B

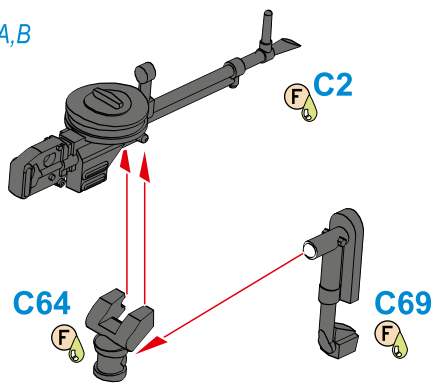

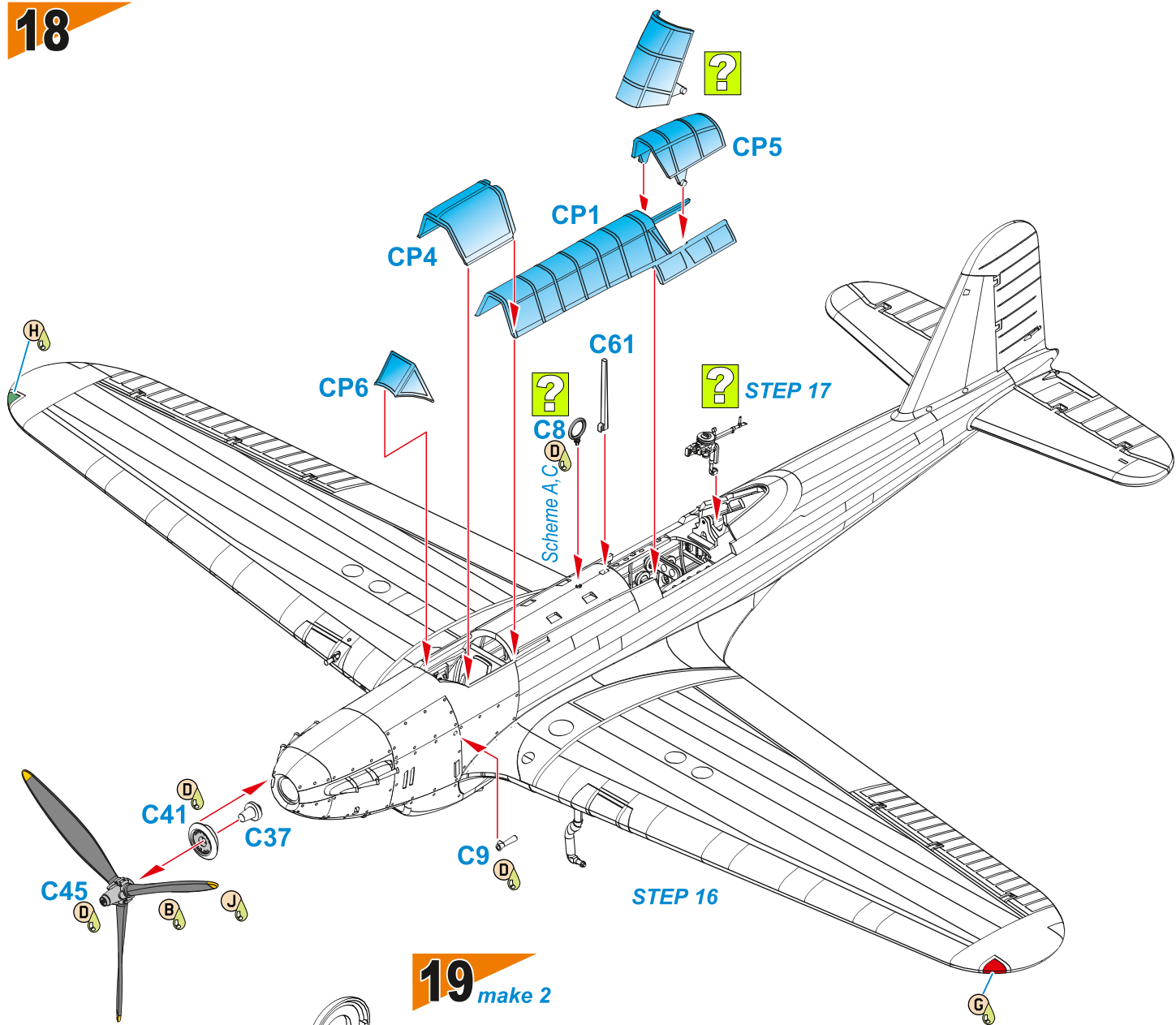

19 make 2

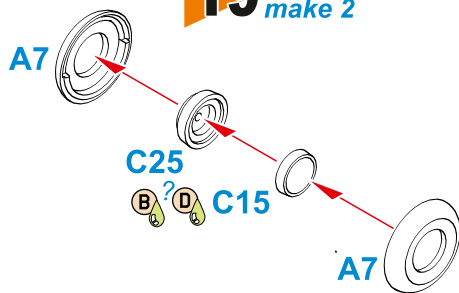

20

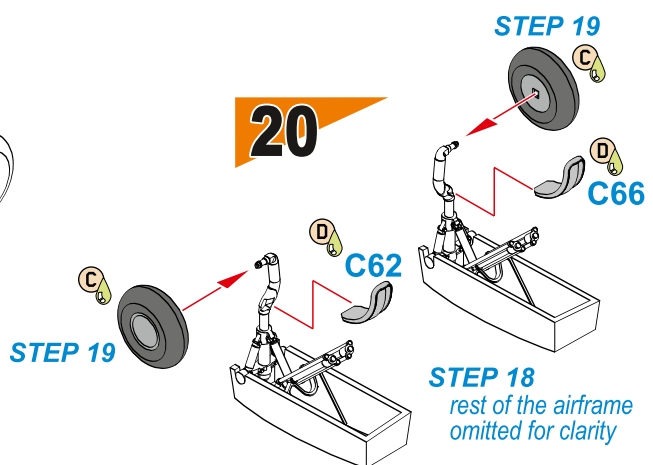

21

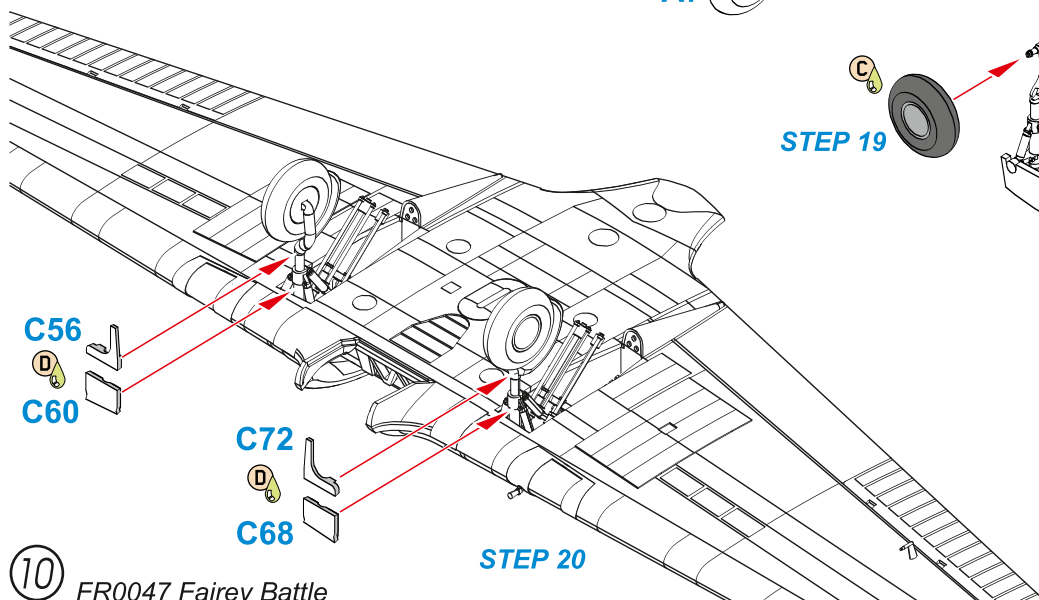

Scheme A

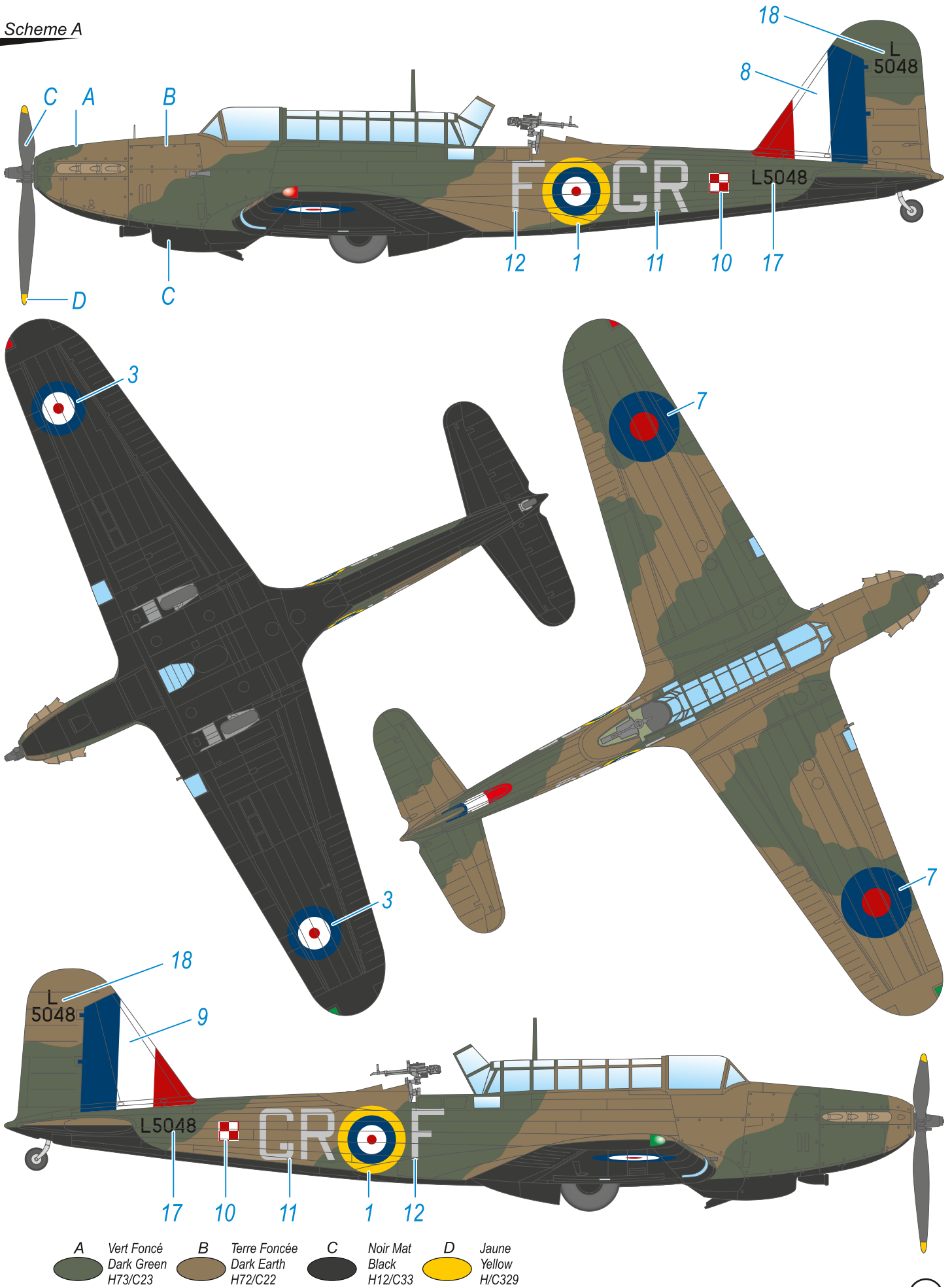

Scheme B

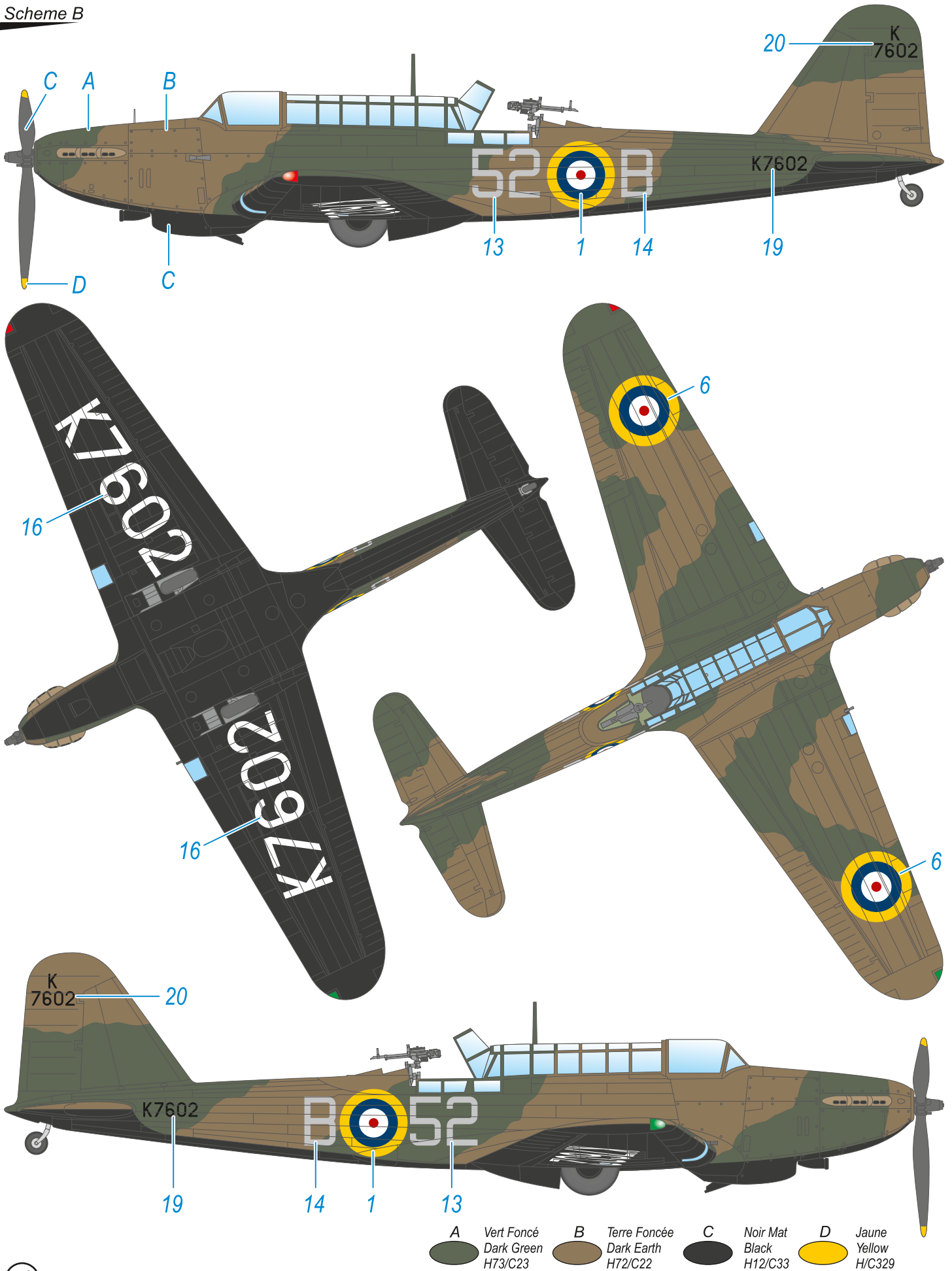

Battle MK.I, 1837 (L1837) codé 59, Force Aérienne Canadienne, Canada. Avant avril 1943 (transformation en TT). Tout le capot supérieur du moteur aurait été noir.

Battle MK.I, 1837 (L1837) coded 59, Royal Canadian Air Force, Canada. Before April 1943, when the aircraft was converted to a TT. The whole upper engine cowling would have been black.

Scheme C

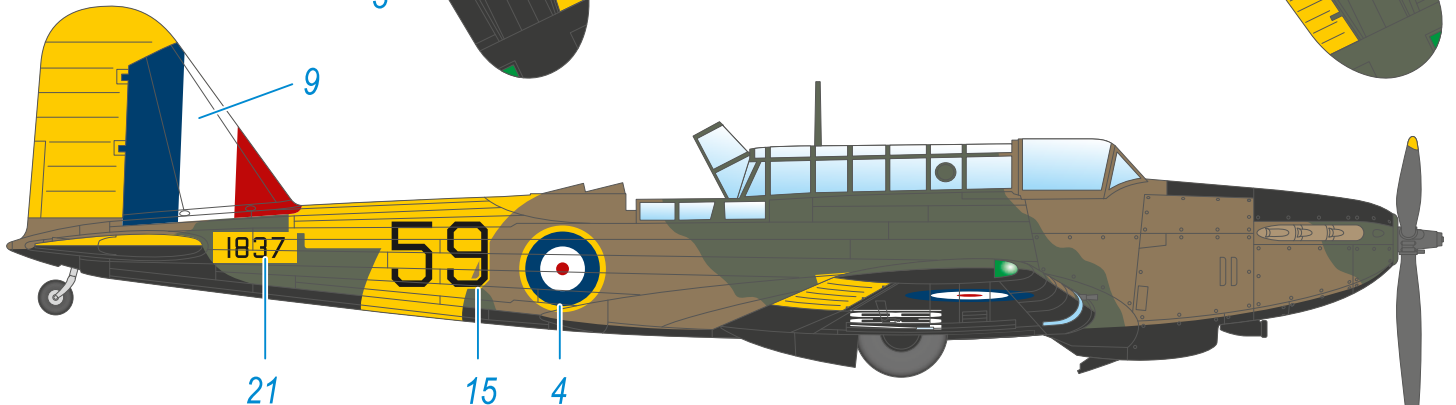
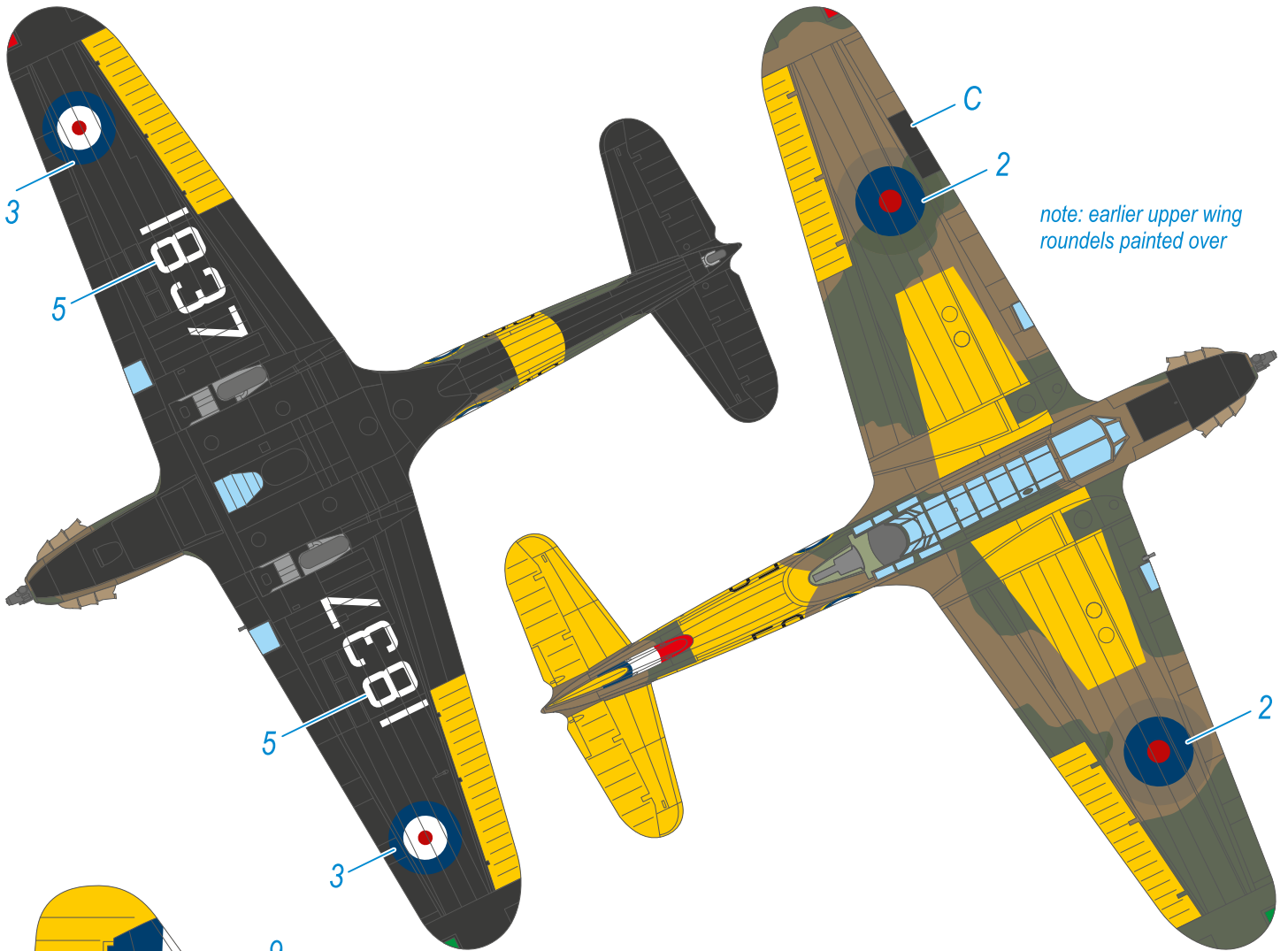
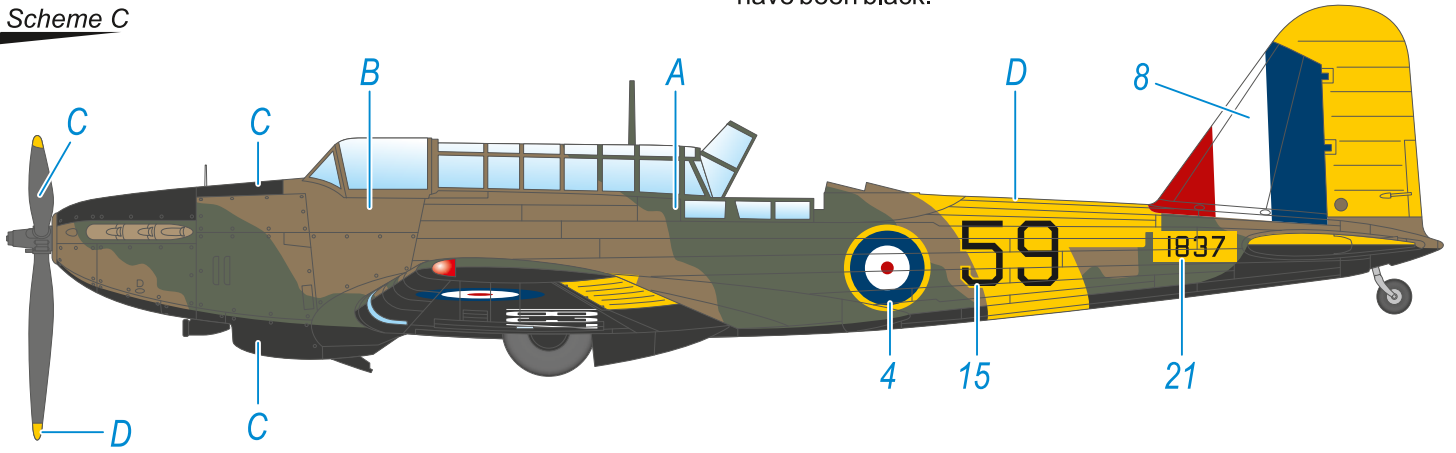

- | | | | | | | | |
|----------|-------------------------------------|----------|---------------------------------------|----------|------------------------------|----------|---------------------------|
| A | Vert Foncé
Dark Green
H73/C23 | B | Terre Foncée
Dark Earth
H72/C22 | C | Noir Mat
Black
H12/C33 | D | Jaune
Yellow
H/C329 |
|----------|-------------------------------------|----------|---------------------------------------|----------|------------------------------|----------|---------------------------|

ATTRACTIVE 1/72 SCALE KITS

FR0022



Dassault Mystère IVA India

FR0023



PZL P.11f in Rumania

FR0027



Stampe S.V.4a Aerobatics

FR0034



Gamma 2E Bomber

FR0037



Potez 25 A2/B2 Lorraine

FR0038



Potez 25 A2/B2 Hispano

FR0039



Renard R-31 Belgium

FR0040



CASA C-212-300 France

ATTRACTIVE 1/72 SCALE KITS

FR0049



SPAD 510 (7 ème Escadre)

FR0050



SPAD 510 at war

FR0053

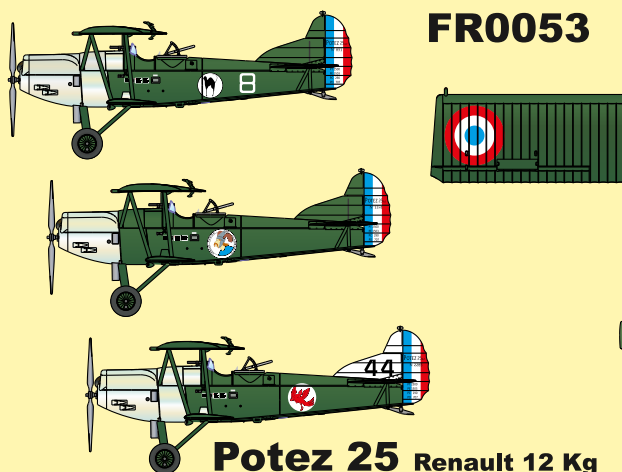

Potez 25 Renault 12 Kg

FR0043



B-10B Export WC/WAN

FR0045

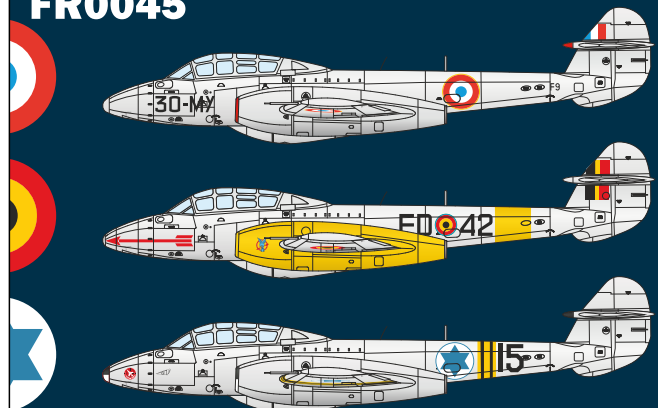

Meteor T.Mk.7

FR0041



SNCASE S.E.535 Mistral

FR0031



Breguet 1050 Alizé 1G India

FR0052



DB-7 in French Service

ATTRACTIVE 1/72 SCALE KITS

FR0055



Bloch MB.210 'Early'

FR0046



Fairey Battle Mk.I 'In Belgium'

FR0048



Fairey Battle Mk.I 'AASF'

WWW.FRRROM.COM