

## 1/72 SCALE PLASTIC KIT

**ProfiPACK**  
edition

# #70129



### INTRO

In September 1941, a hitherto unknown German radial engine fighter appeared in the west European sky. The new airplane was superior to British fighters, most distressingly to the Spitfire Mk.V. The German design was soon recognized as the Focke-Wulf Fw 190A. The losses suffered by the RAF over western Europe rose rapidly and the crisis was serious enough that the RAF ceased the majority of daytime operations in November 1941. The next attempt to resume these types of sorties was made in March 1942. Loss rates remained unacceptably high and the RAF was forced to stop ops once again. All this was thanks to the Focke-Wulf Fw 190A. The first response to the new German weapon was the Spitfire Mk.VIII, but the design changes were so complex that initiating timely production was not possible. In June 1942 a German pilot landed by mistake on a British airfield delivering a completely intact Fw 190 fighter into RAF hands. Comparative trials between the Focke-Wulf and Spitfire Mk.V began almost immediately. These mock encounters confirmed the situation over the front – the chances of a British fighter surviving an encounter with the Fw 190 were slim. The only British fighter aircraft deemed suitable to oppose them were the Spitfire Mk. VII and VIII powered by the Merlin 61 engine. As mentioned above these were some time away of being ready for series production. But there was another way of getting a powerful fighter quickly - by mating the Merlin 61, with its two-stage supercharger, with the fuselage of the Spitfire Mk.Vc. Two Mk.Vc airframes, AB196 and AB197, were selected for this purpose and were strengthened with modified longerons to accommodate the more powerful and heavier engine. The example was finished on February 26<sup>th</sup> and the second on March 27<sup>th</sup>, 1942. Flight trials were successful and the order for series production was issued almost immediately. Series production began in June 1942 and the first Mk.IXs found their way to No. 64 Squadron in July. Performance improved significantly in comparison to the Mk.V. A top speed of 409 mph at 28,000 feet was higher by 40 mph, and the service ceiling rose from 36,200 to 43,000 feet. The Mk.IX could climb at 4,000 feet per minute. The RAF finally had a fighter aircraft capable of opposing the Fw 190A. Three main versions of the Mk. IX were produced. The F.IX was powered by the Merlin 61 and was the only version on the assembly line in early 1943. The next version was the LF Mk.IX powered by the Merlin 66. This engine was designed to do its best at low altitudes. The third version, manufactured along with the LF, was the high-altitude HF Mk.IX with the Merlin 70. The majority of Mk.IXs manufactured were equipped with the so-called 'C' wing. Four 20 mm cannons or two 20 mm cannons and four .303 machine guns could be installed in the wings. From 1944 the strengthened 'E' wing was produced. Four .303 machine guns were replaced with two .50 heavy machine guns. Bomb racks for 250 lb bombs were fitted under each wing typically. The Mk.IX became the second most numerous version of the Spitfire with a total of 5653 examples being built. The Mk.IX began to replace the Mk.V from June 1942. Thanks to the new fighter, the RAF was ready to fight against the Luftwaffe over occupied Europe. Spitfire Mk.IXs served with the RAF to the end of war. In the postwar era, foreign air forces flew this version as well. Czechoslovak, Norwegian, Danish, and Canadian air forces operated numbers of Mk.IXs and they were not alone. Spitfires would find themselves in combat again. Czechoslovakia sold its Spitfire Mk.IXs to Israel in 1948 and these aircraft formed the backbone of the newly born Israeli air force in the fight against their Arab neighbours.

ATTENTION

\* UPOZORNĚNÍ

\* ACHTUNG

\* ATTENTION

\* 注意



Carefully read instruction sheet before assembling. When you use glue or paint, do not use near open flame and use in well ventilated room. Keep out of reach of small children. Children must not be allowed to suck any part, or pull vinyl bag over the head.



Před započatím stavby si pečlivě prostudujte stavební návod. Při používání barev a lepidel pracujte v době větrané místnosti. Lepidla ani barvy nepoužívejte v blízkosti otevřeného ohně. Model není určen malým dětem, mohlo by dojít k požití drobných dílů.

INSTRUCTION SIGNS \* INSTR. SYMBOLS \* INSTRUKTION SINNBILDEN \* SYMBOLES \* 記号の説明

OPTIONAL  
VOLBABEND  
OHNOUITSAND  
BROUSITOPEN HOLE  
VYVRTAT OTVORSYMETRICAL ASSEMBLY  
SYMETRICKÁ MONTÁŽREMOVE  
ODRÁZNOUITREVERSE SIDE  
OTOČITAPPLY EDUARD MASK  
AND PAINT  
POUŽIT EDUARD MASK  
NABARVIT

PARTS

\* DÍLY

\* TEILE

\* PIĚCES

\* 部品

## PLASTIC PARTS

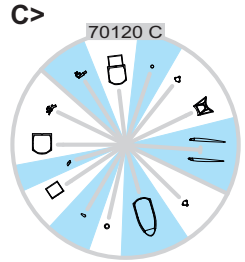
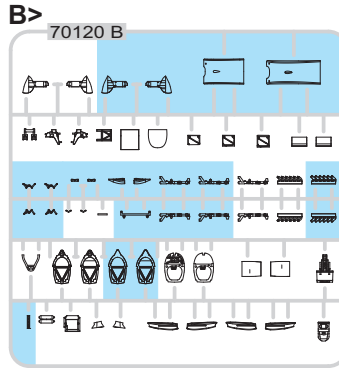
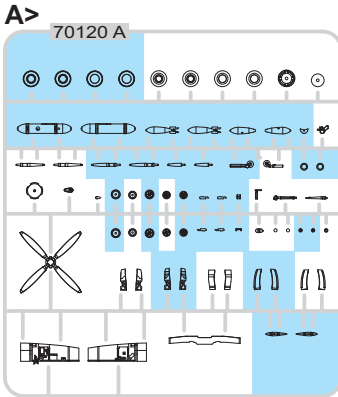

**D>**  
70120 D

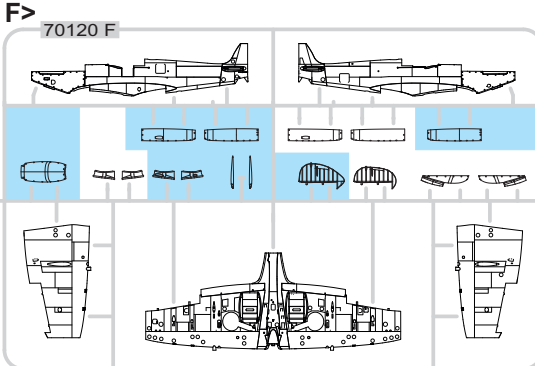

**E>**  
70120 E



eduard  
MASK

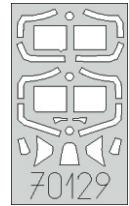

PE - PHOTO ETCHED  
DETAIL PARTS

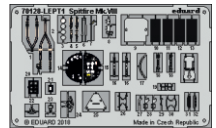

Parts not for use. -Teile werden nicht verwendet. -Pièces à ne pas utiliser. -Tyto díly nepoužívejte při stavbě. - 使用しない部品

COLOURS

\* BARVY

\* FARBEN

\* PEINTURE

\* 色

| GSI Creos (GUNZE) |          | MISSION MODELS |                 |  |
|-------------------|----------|----------------|-----------------|--|
| AQUEOUS           | Mr.COLOR | PAINTS         |                 |  |
| [H4]              | C4       | [MMP-007]      | YELLOW          |  |
| [H12]             | C33      | [MMP-047]      | FLAT BLACK      |  |
| [H13]             | C3       | [MMP-003]      | FLAT RED        |  |
| [H33]             | C81      |                | RUSSET          |  |
| [H51]             | C11      | [MMP-063]      | LIGHT GULL GRAY |  |
| [H71]             | C21      | [MMP-076]      | MIDDLE STONE    |  |
| [H72]             | C22      | [MMP-078]      | DARK EARTH      |  |
| [H77]             | C137     | [MMP-040]      | TIRE BLACK      |  |
| [H90]             | C47      |                | CLEAR RED       |  |
| [H94]             | C138     |                | CLEAR GREEN     |  |

| GSI Creos (GUNZE)       |          | MISSION MODELS |                     |  |
|-------------------------|----------|----------------|---------------------|--|
| AQUEOUS                 | Mr.COLOR | PAINTS         |                     |  |
| [H339]                  | C361     | [MMP-077]      | DARK GREEN          |  |
| [H335]                  | C363     | [MMP-094]      | MEDIUM SEAGRAY      |  |
|                         | C362     | [MMP-093]      | OCEAN GRAY          |  |
|                         | C364     | [MMP-079]      | AIRCRAFT GRAY-GREEN |  |
|                         | C370     | [MMP-092]      | AZURE BLUE          |  |
| Mr.METAL COLOR          |          | METALLICS      |                     |  |
| [MC214]                 |          | [MMM-001]      | DARK IRON           |  |
| [MC218]                 |          | [MMM-003]      | ALUMINIUM           |  |
| Mr.COLOR SUPER METALLIC |          | METALLICS      |                     |  |
| [SM01]                  |          | [MMC-001]      | SUPER CHROME        |  |

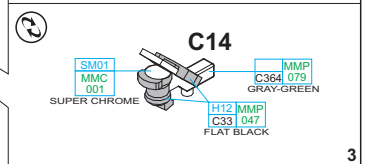
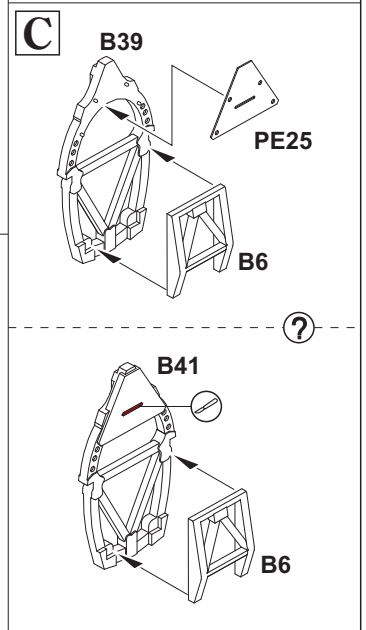
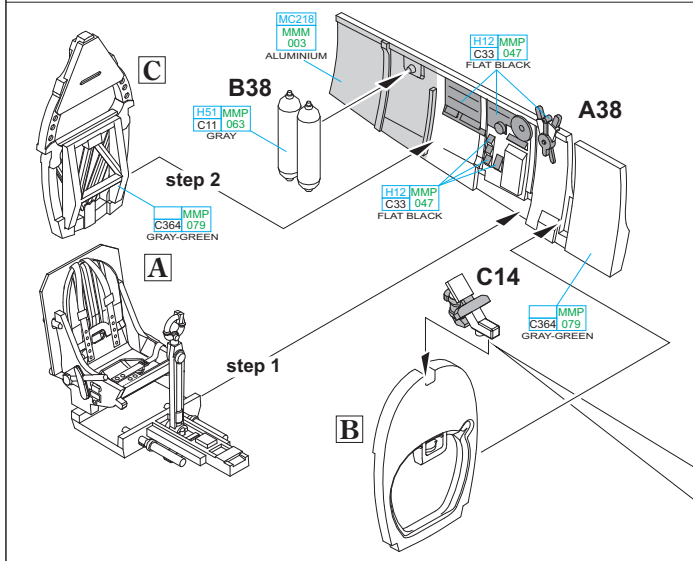
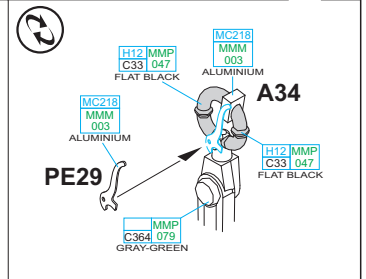
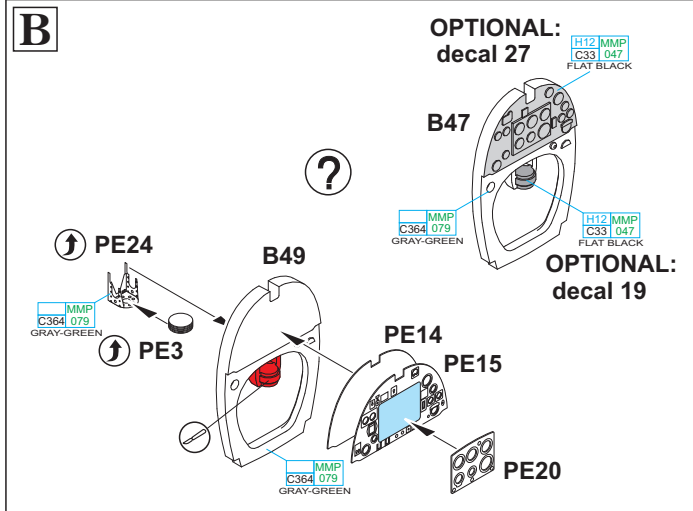
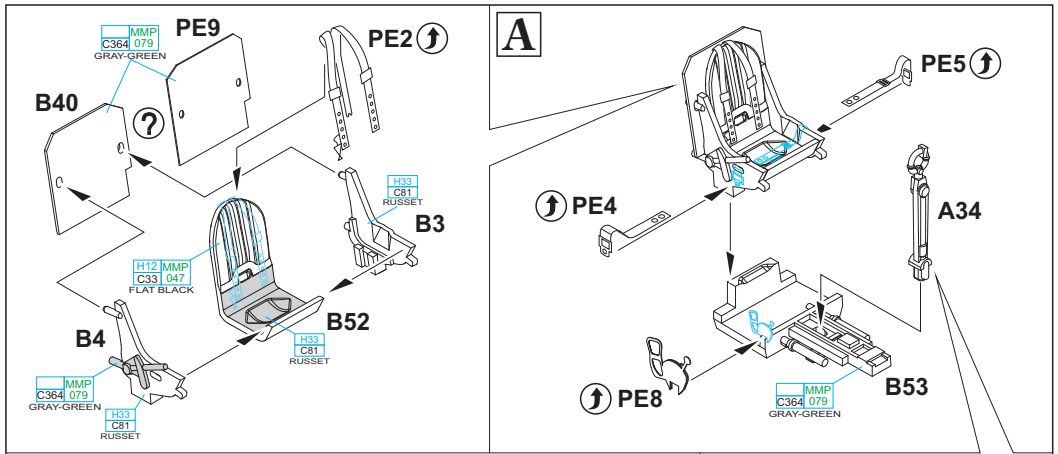

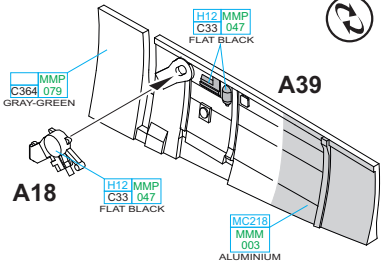
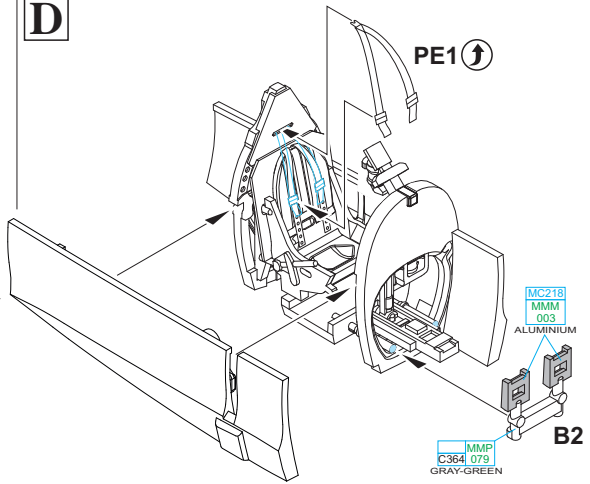
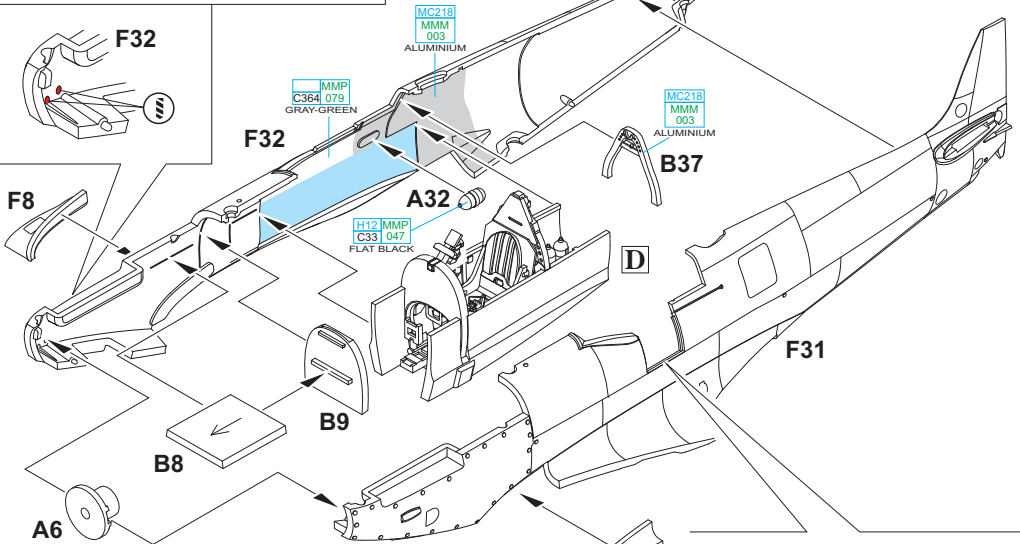
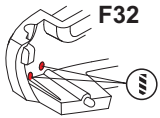
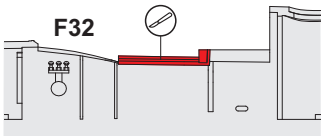
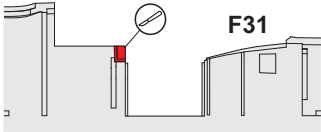
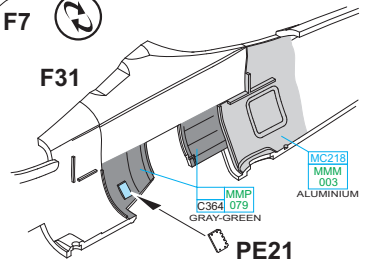
**D****PE1** ↑**? FOR CLOSED CANOPY ONLY****F7** ↻

**C4**  

|      |
|------|
| H94  |
| C138 |

 CLEAR GREEN 

|      |
|------|
| ?    |
| SM01 |
| MMC  |
| 001  |

 SUPER CHROME

|                        |      |                           |
|------------------------|------|---------------------------|
| H90                    | H94  | - MARKINGS <b>A;B;D;E</b> |
| C47                    | C138 |                           |
| CLEAR RED, CLEAR GREEN |      |                           |
| SM01                   |      | - MARKING <b>C</b>        |
| MMC                    | 001  |                           |
| SUPER CHROME           |      |                           |

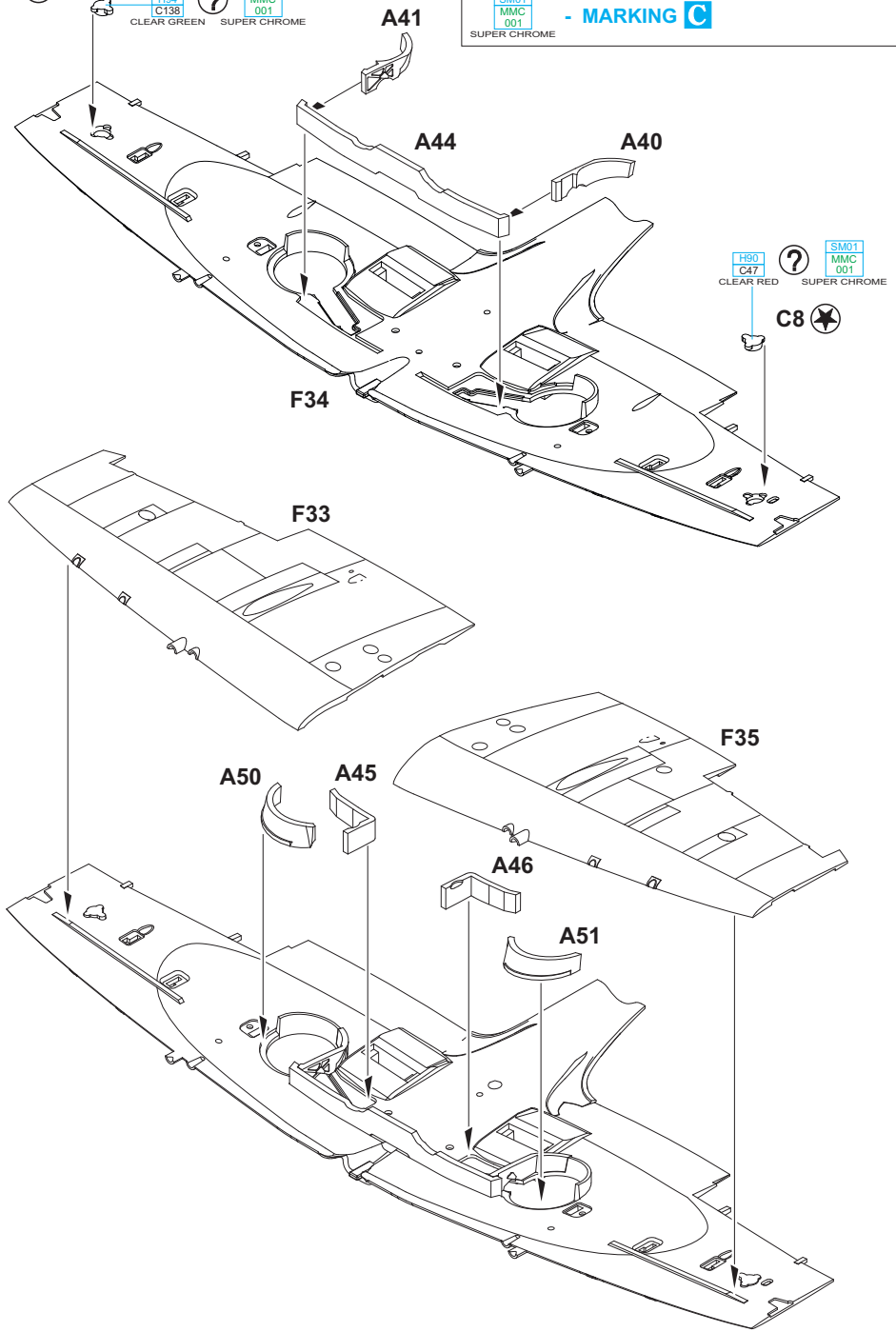

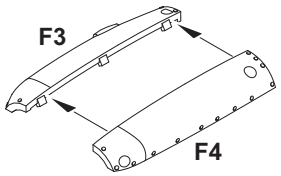

MMP  
C364 079  
GRAY-GREEN

B21

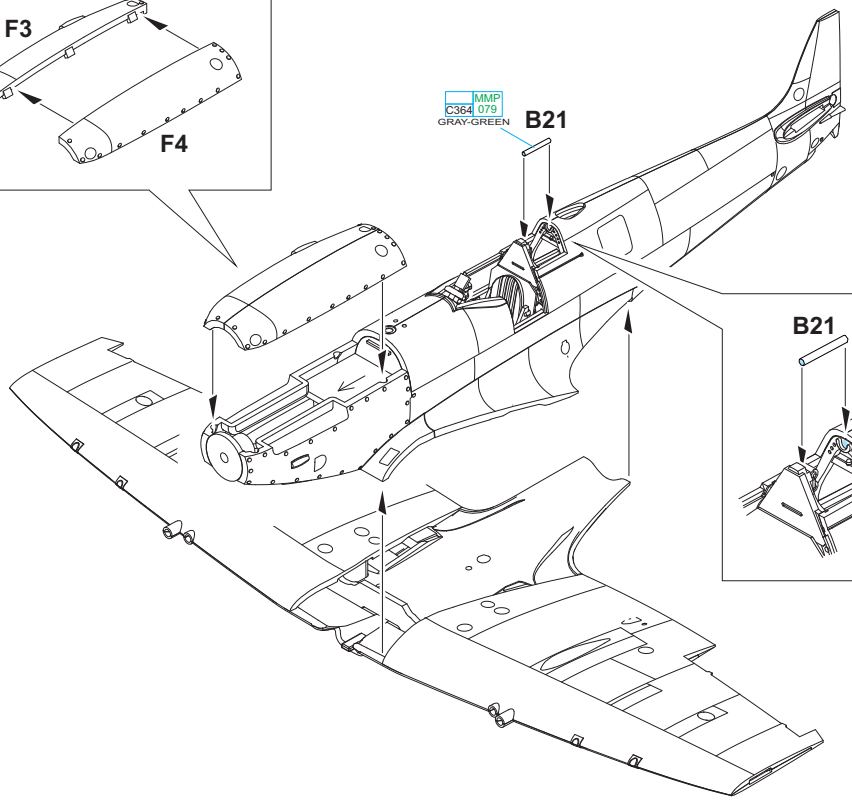

B21

B37

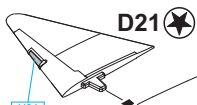
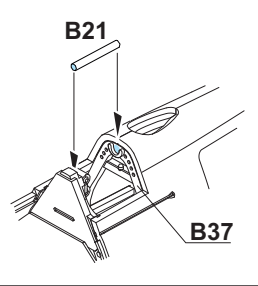

H94  
C138  
CLEAR GREEN

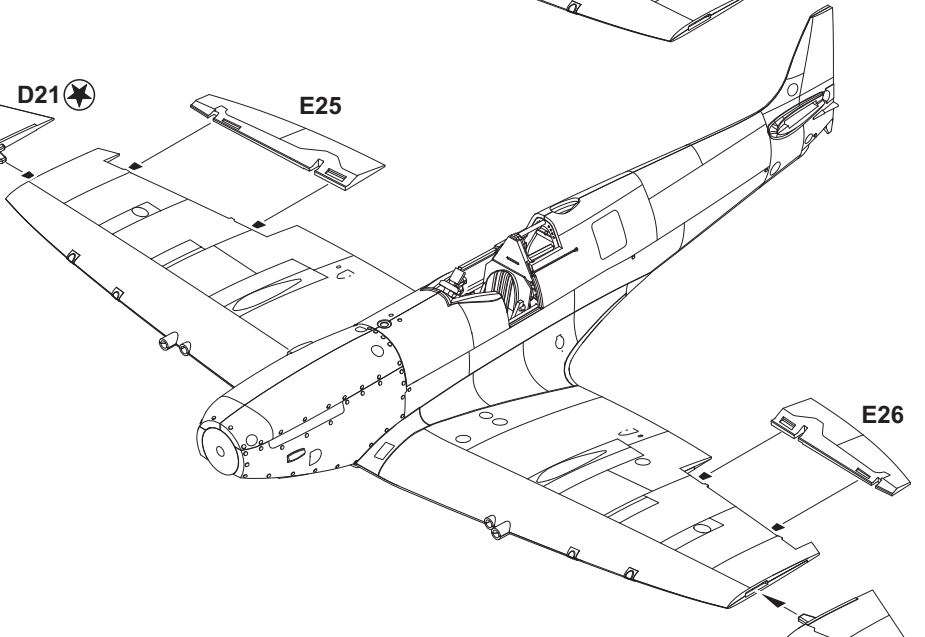

E26

D22

H90  
C47  
CLEAR RED

D23

F14

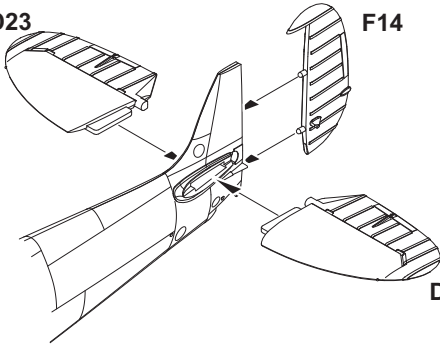

D24

H77 MMP  
C137 040  
TIRE BLACK

A15

M218  
ALUMINIUM

UNDERSURFACE  
COLOR

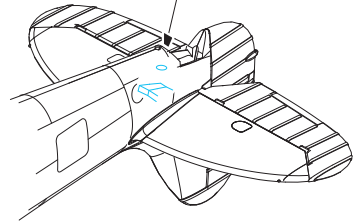

B42

UNDERSURFACE  
COLOR

B44

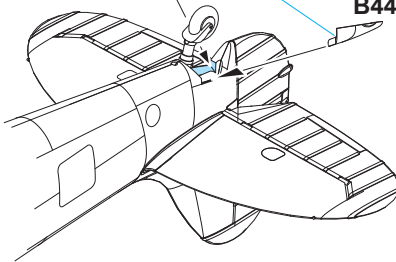

B42

B44

F31

F32

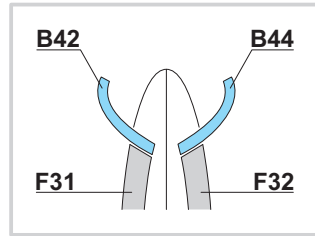

**E**

PE31, PE32 - MARKINGS  
A, B, D, E ONLY

F16

PE31

↑ PE32

UNDERSURFACE  
COLOR

F15

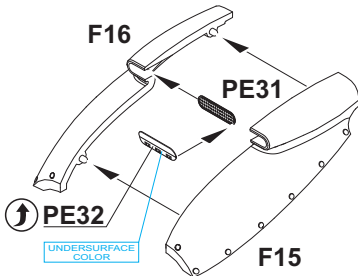

PE32

PE31

F15, F16

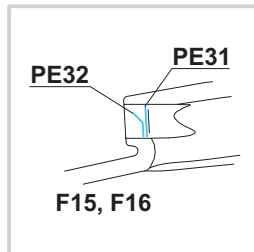

**F**

PE27

UNDERSURFACE  
COLOR

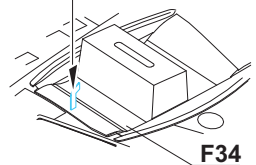

F34

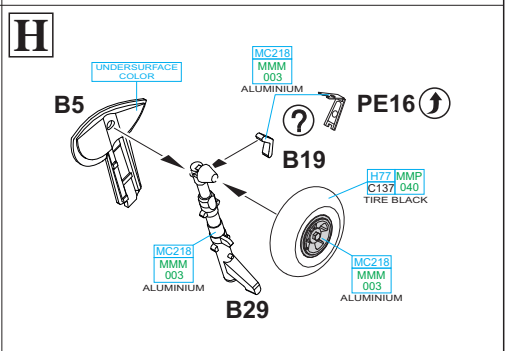
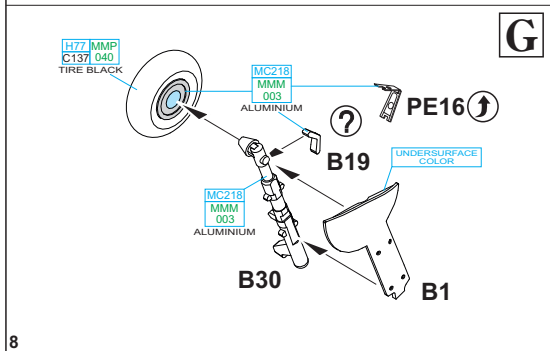
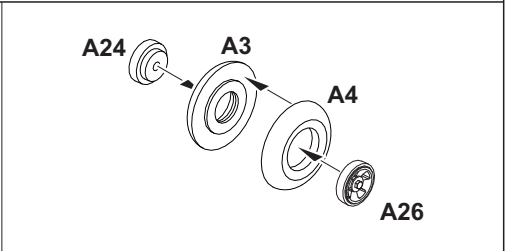
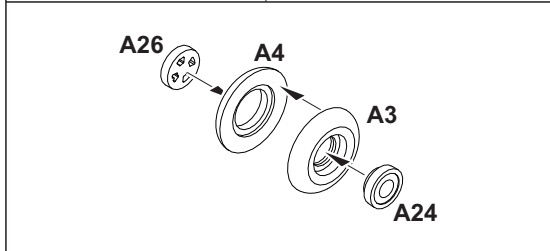
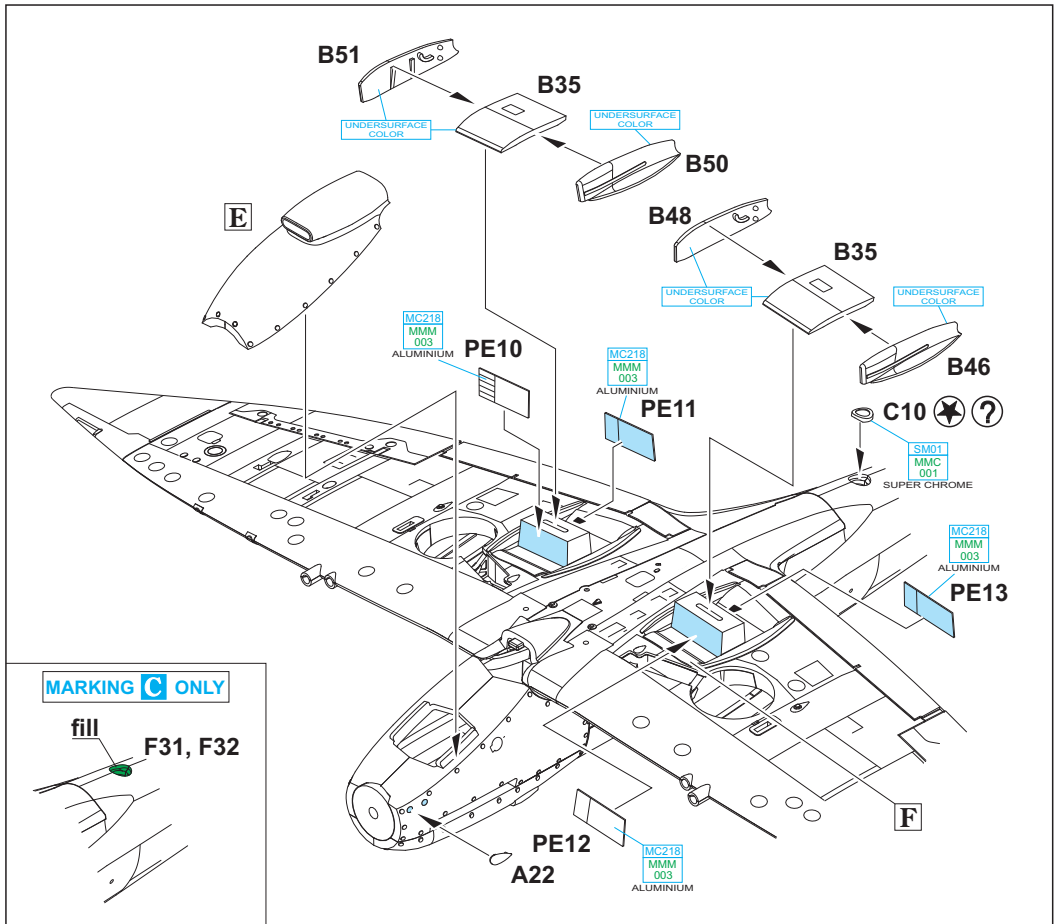



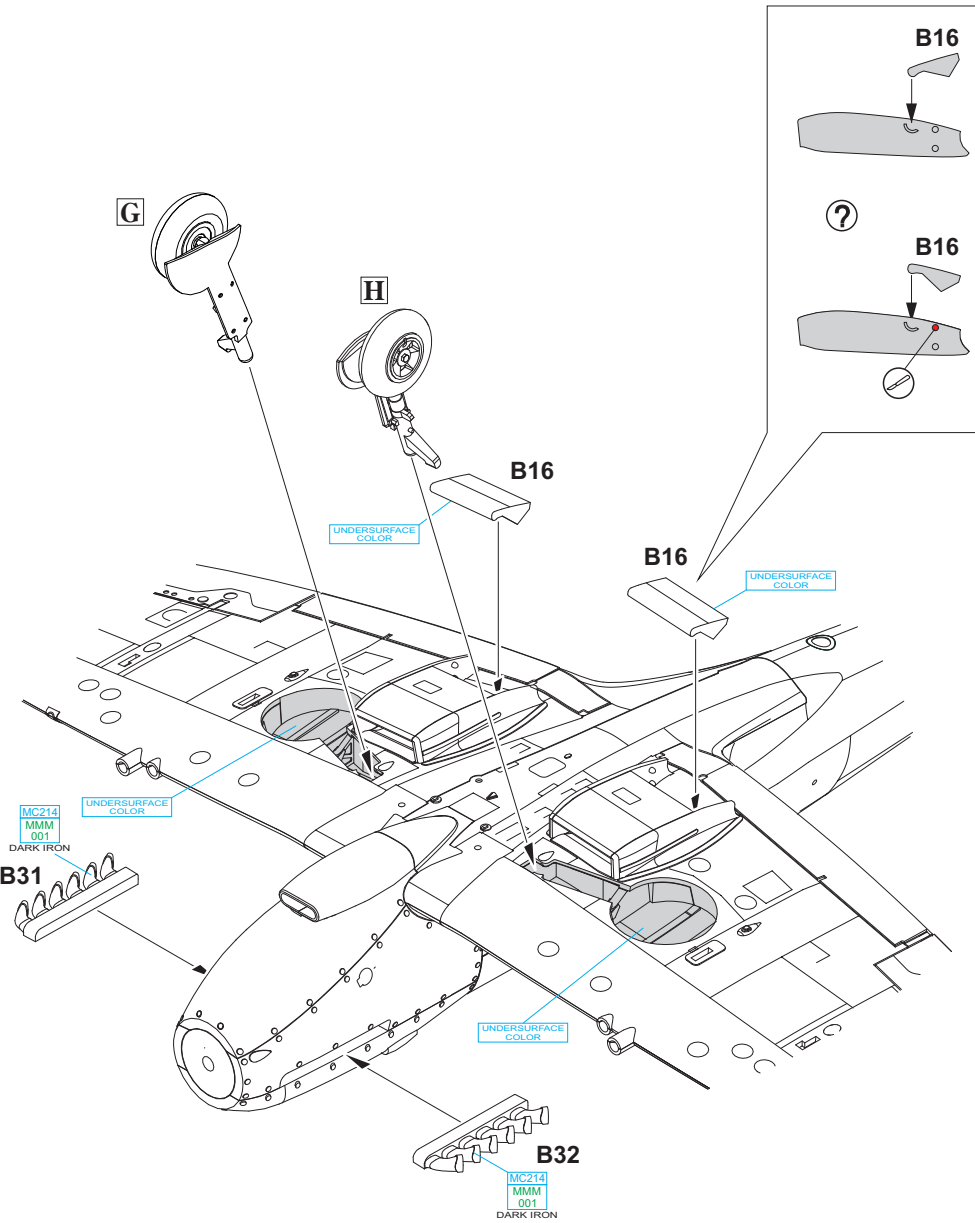

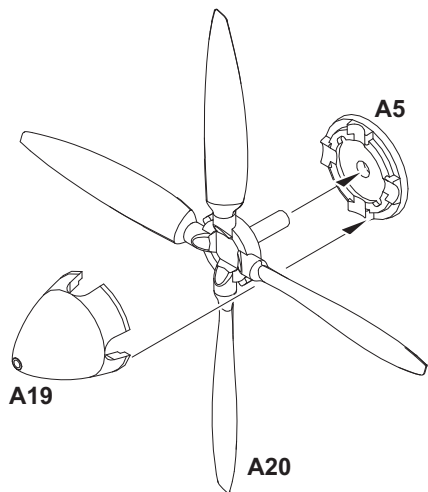
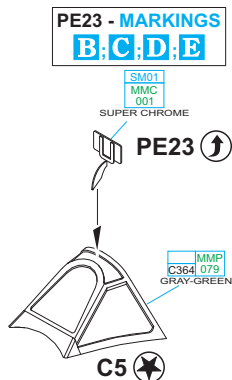
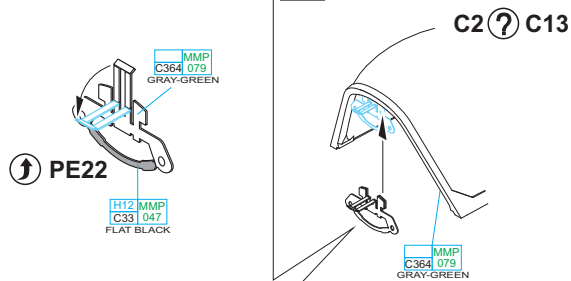
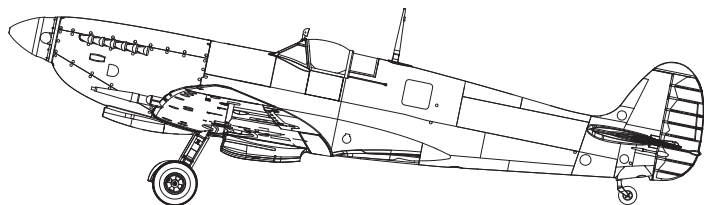
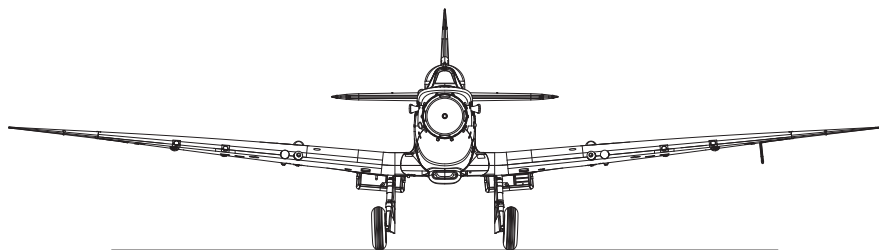
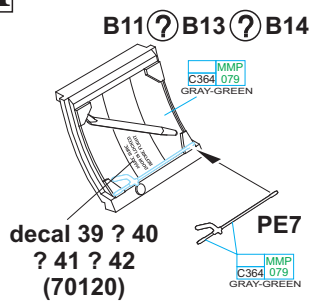
**J****K****L****M**

**B11 - closed canopy & closed door**

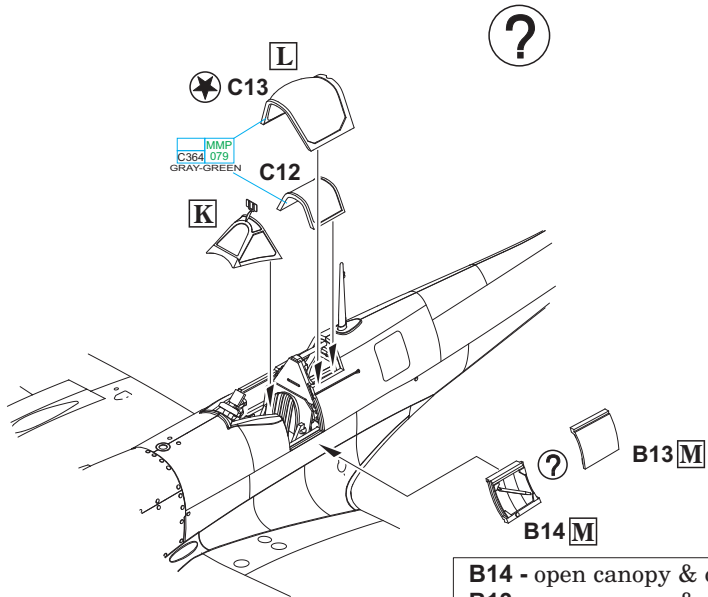
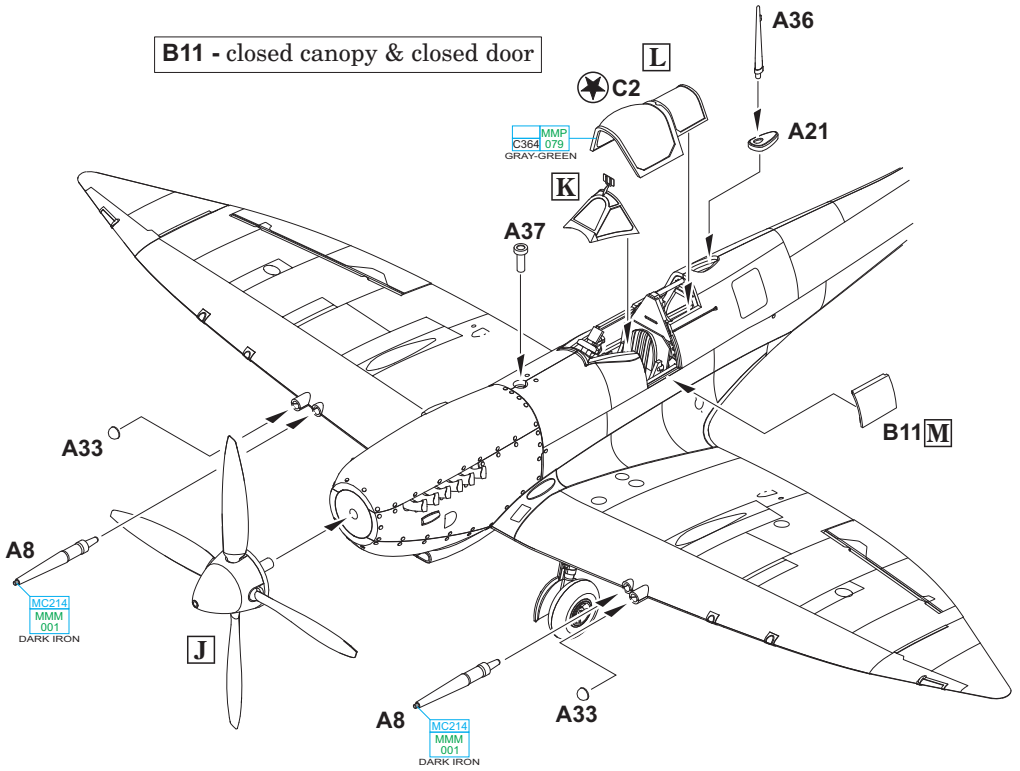

**B14 - open canopy & open door**  
**B13 - open canopy & closed door**

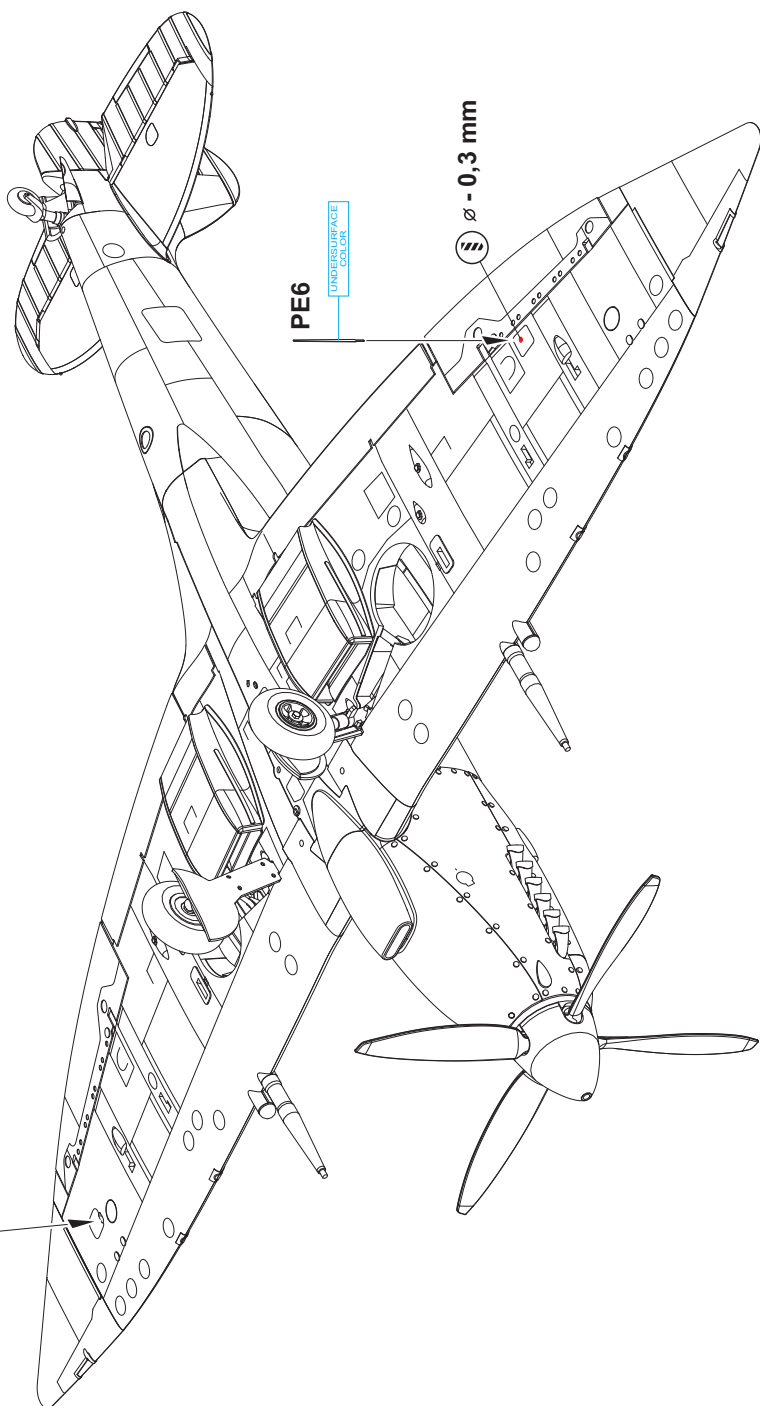

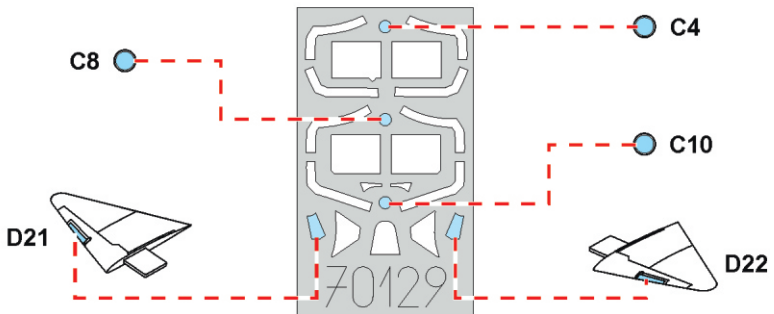
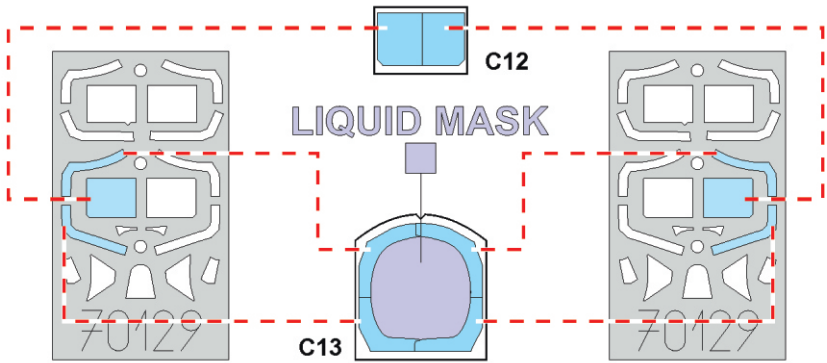
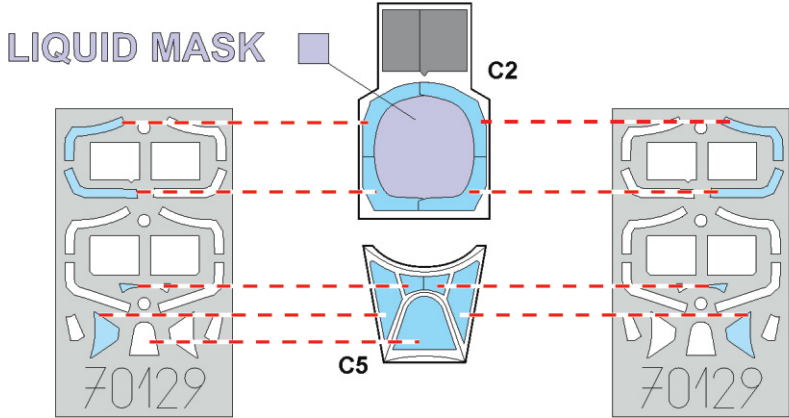
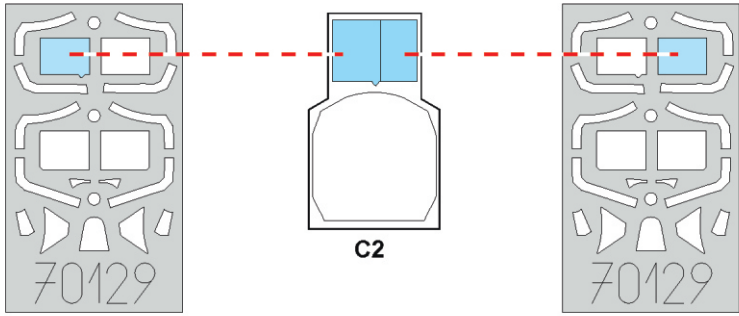

# A JF476, No. 92 Squadron, Triolo, Sicily, November 1943

Originally No. 92 Fighter Squadron fighting in WWI was cancelled in August 1919. On October 10th, 1939 a squadron bearing the same number was established. It was first equipped with Bristol Blenheims. Right at the beginning of year 1940 it got Spitfires, which were fighting above Dunkerque and also fought in the Battle of Britain. In February 1942 the squadron was sent to Africa where it served against German and Italian armed forces. After the fights in Africa terminated, the squadron fought above Malta and Sicily, later the squadron served above Italy. The squadron was disbanded on December 30th, 1946 in Austrian Zeltweg. During WWII it reached the highest number of shot downs of the enemy aircraft among the RAF Wings, 317 victories over the enemy aircraft. No. 92 Squadron aircraft had a Desert Scheme Camouflage. This consisted of Dark Earth and Middle Stone colours on the top surfaces, the undersides were painted in Azure Blue colour. The colour of the letters of coding of the squadron could not be clearly determined, various sources state blue and red. Both sides of the fuselage bore Desert Air Force sign.

H13 MMP  
C3 003

H72 MMP  
C22 078

H71 MMP  
C21 076

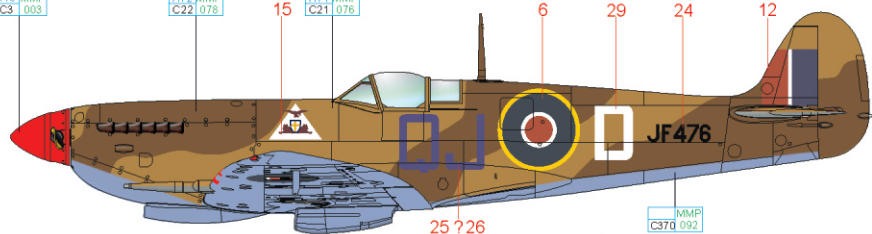

25 ? 26

MMP  
C370 092

ČESKOU VERZI TEXTU NALEZNETE NA  
[www.eduard.cz](http://www.eduard.cz)  
POD KATALGOVÝM ČÍSLEM 70129

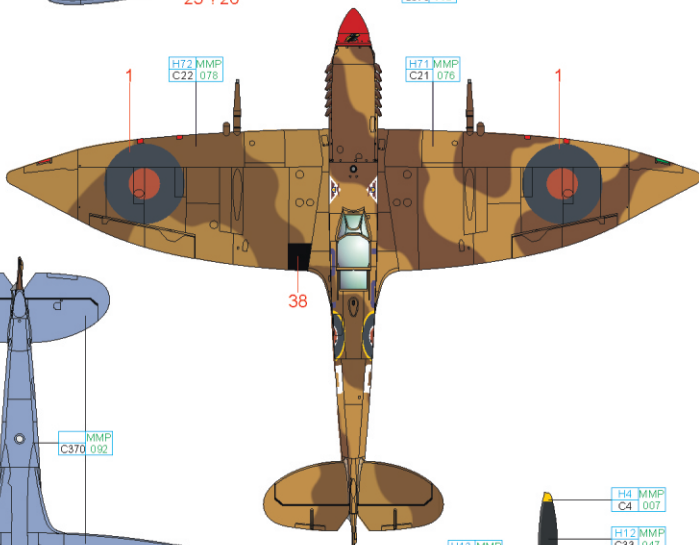

H72 MMP  
C22 078

H71 MMP  
C21 076

38

MMP  
C370 092

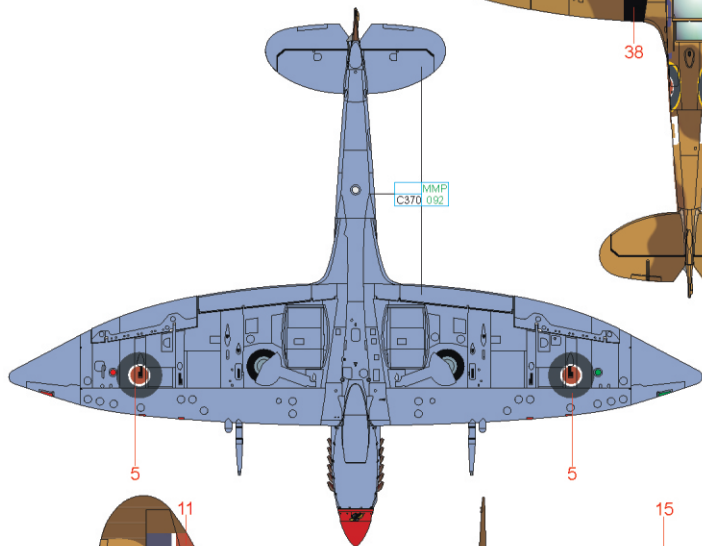

5

5

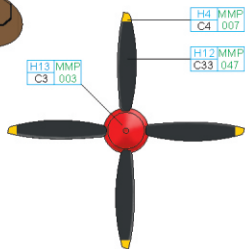

H4 MMP  
C4 007

H12 MMP  
C33 047

H13 MMP  
C3 003

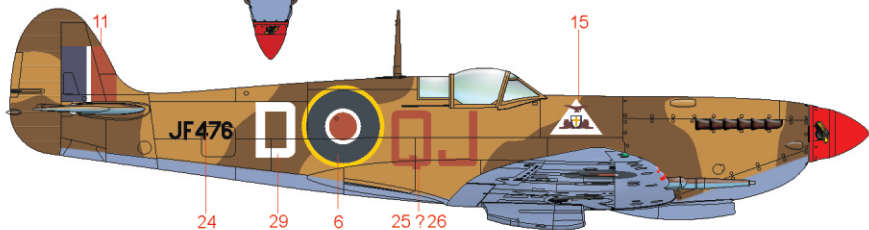

11

15

24

29

6

25 ? 26

RED H13 MMP C3 003 LIGHT YELLOW H4 MMP C4 007

AZURE MMP C370 092 MIDDLE STONE H71 MMP C21 076 DARK EARTH H72 MMP C22 078 BLACK H12 MMP C33 047

eduard

## B JF519, No. 1 Squadron SAAF, Trigno, Italy, February 1944

No. 1 Squadron SAAF was established in February 1940 by renaming of the No. 6 Squadron SAAF armed with Hawker Hurricane and Fury aircraft. In the mid of the year 1940 the pilots of this unit joined the fights above North Africa. At the turn of 1942 and 1943 the squadron received Spitfires and flew them in the fights under the African sun. These fights were followed by the use of these aircraft above Malta and Sicily. The wartime presence of the squadron finished in Italy. After WWII, the squadron remained active, first with Spitfires, Vampire, Sabre and Impala and then, in April 1975, the squadron was rearmed with French Mirage F.1. The squadron was disbanded on November 25th, 1997 at the Hoedspruit Base. The Mk.VIII Spitfires used by No. 1 Squadron SAAF above Italy had a Day Fighter Camouflage Scheme. The upper surfaces were painted in Ocean Grey and Dark Green; the undersides with Medium Sea Grey colour. The wing tips of Spitfires were painted red.

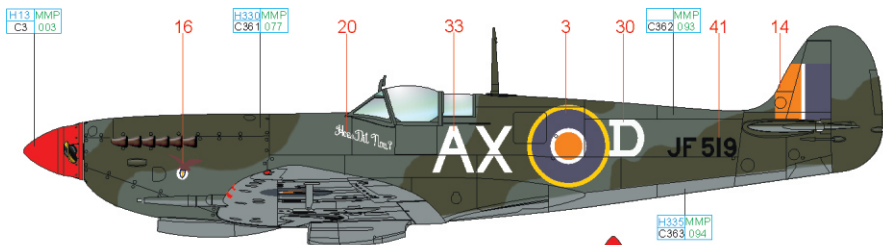

ČESKOU VERZI TEXTU NALEZNETE NA  
[www.eduard.cz](http://www.eduard.cz)  
POD KATALOGOVÝM ČÍSLEM 70129

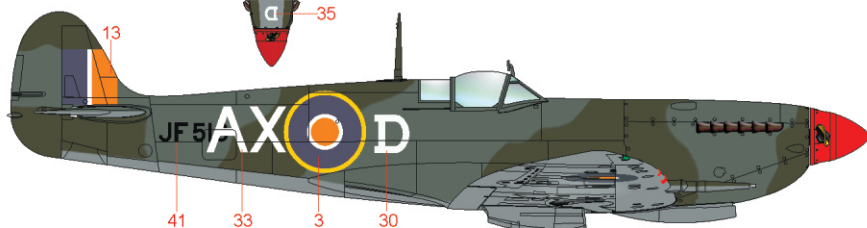
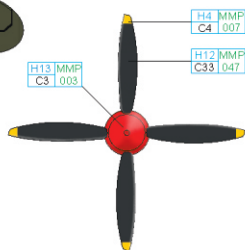
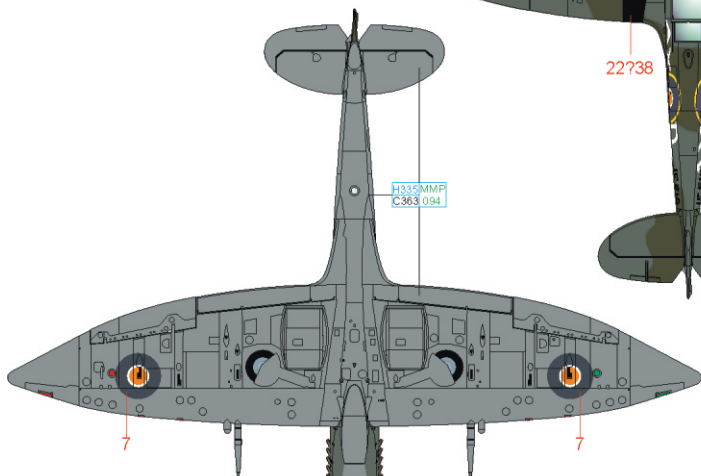
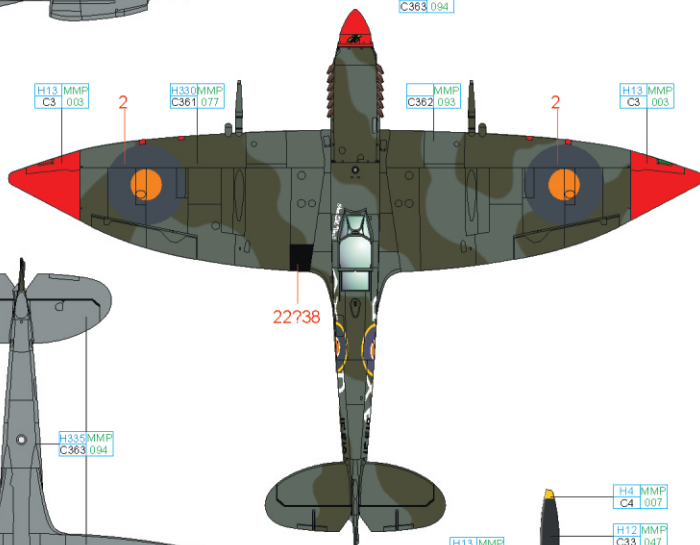

|                 |                   |              |                   |
|-----------------|-------------------|--------------|-------------------|
| RED             | H13 MMP C3 003    | LIGHT YELLOW | H4 MMP C4 007     |
| MEDIUM SEA GRAY | H335 MMP C363 094 | OCEAN GRAY   | MMP C362 093      |
|                 |                   | DARK GREEN   | H330 MMP C361 077 |
|                 |                   | BLACK        | H12 MMP C33 047   |

## C JF630, flown by F/O L. Cronin, No. 81 Squadron, Palel, India, March 1944

According to the interview with Larry Cronin the squadron A/C retained their desert colours. The pilot maintains that his aircraft still had its extended wingtips when he gained his victories. In November 1943, No. 81 Squadron, RAF, withdrew from Sicily to Egypt where they re-equipped with Spitfire Mk.VIII aircraft. Cronin recalls that all these aircraft were in the JF serial range and had extended wingtips and standard rudders. Photos of aircraft in this serial batch showing this configuration support his comments. Most sources state that the aircraft were re-camouflaged in Dark Earth, Dark Green and Sea Grey Medium when they arrived in India. The comments in those sources appear to be based on an order issued by RAF Headquarters, New Delhi. The date of the order is April 4th, 1944, some three months after No.81 Squadron's arrival in the theatre, and a month after the only known photos of Cronin's aircraft were taken.

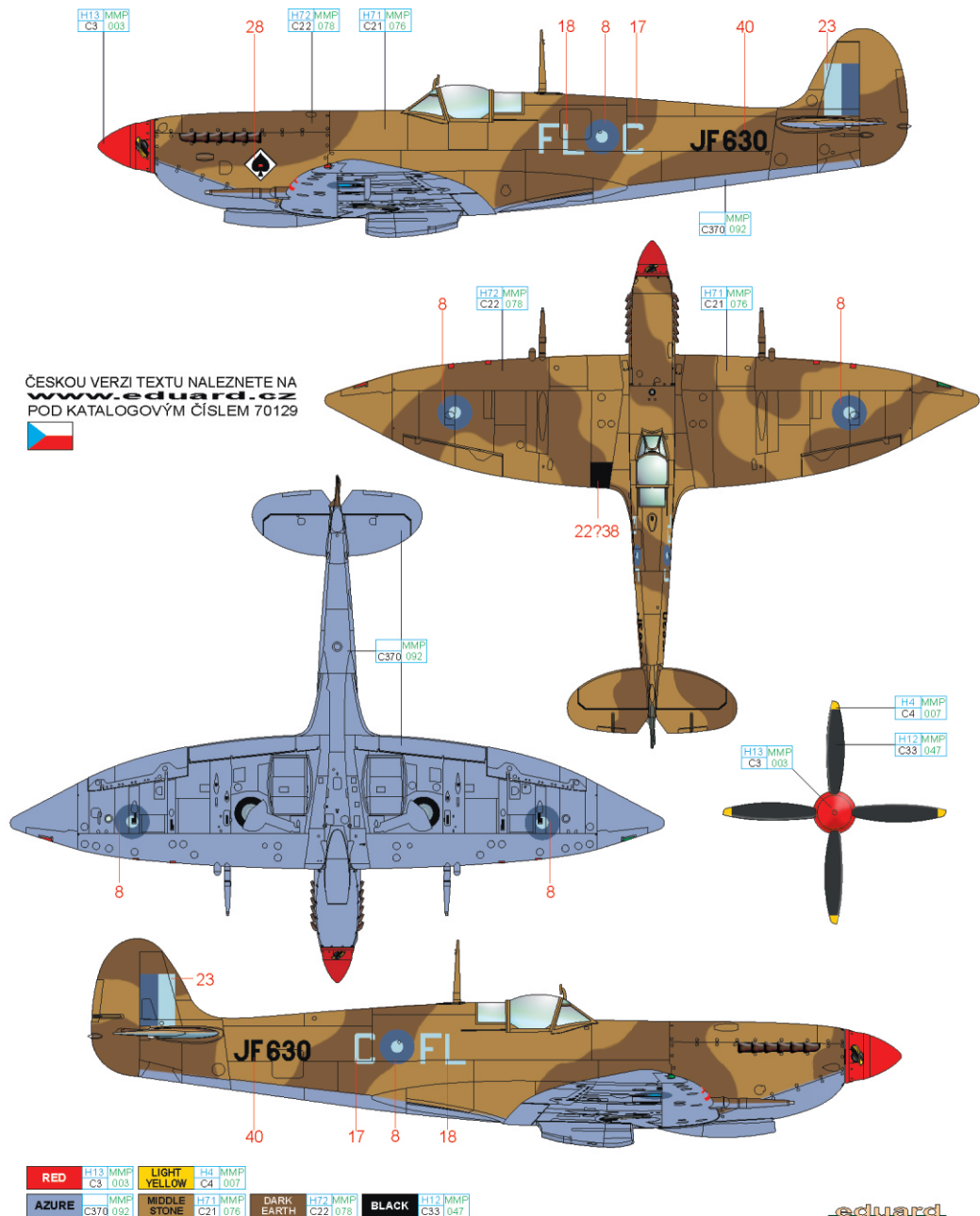



## D JF404, No. 32 Squadron, Foggia, Italy, early 1944

The high altitude fighter camouflage scheme adorned this Spitfire as well. In accordance with regulations, red-blue cockades were painted on the fuselage and upper sides of the wings. No national insignia was applied on the bottom of the wings. A photo of this aircraft shows that the GZ code letters did not adhere to regulations on the right side of the fuselage.

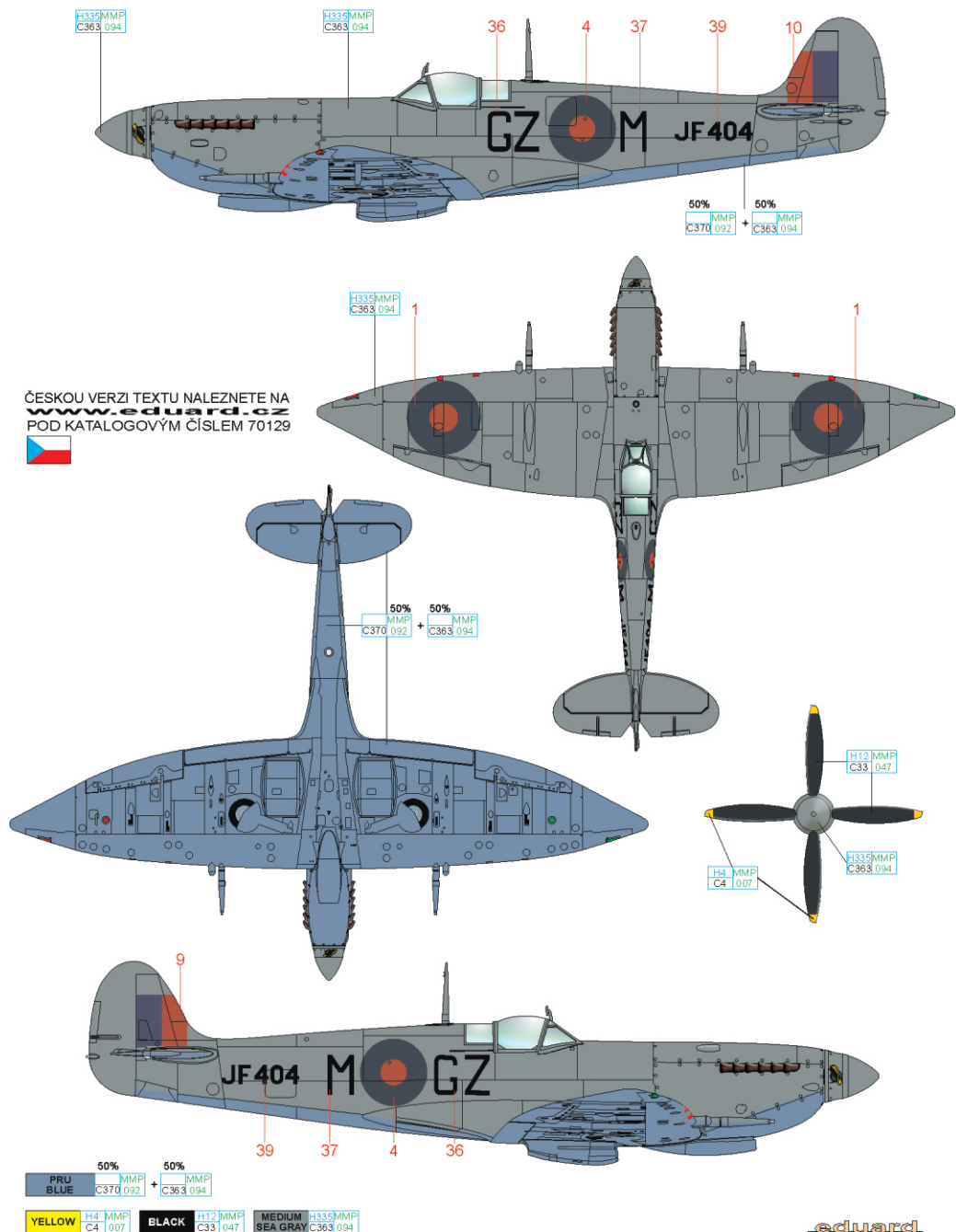

# E 308th Fighter Squadron, 31st Fighter Group, Castel Volturno, Italy, 1944

308th Fighter Squadron was armed with P-39s and P-40s. The performance of these fighters was not enough to keep up with German opponents, which led to a relatively quick rearmament to Spitfires Mk.V. The Spitfires were used by 31st Fighter Group in a two-month heavy fights above northern France. Later the group was transferred to Gibraltar to use the base for take offs for Algeria as part of the disembarkation of the Allies in North Africa (Operation Torch). What followed were the fights against the forces of the Axis in North Africa. In May 1943 the 308th Fighter Squadron received Spitfires Mk.VIII, which were than used in the fights above Sicily and Italy. In March 1944, the Spitfires were replaced by P-51 Mustangs, which were used by 308th Fighter Squadron pilots till the end of war.

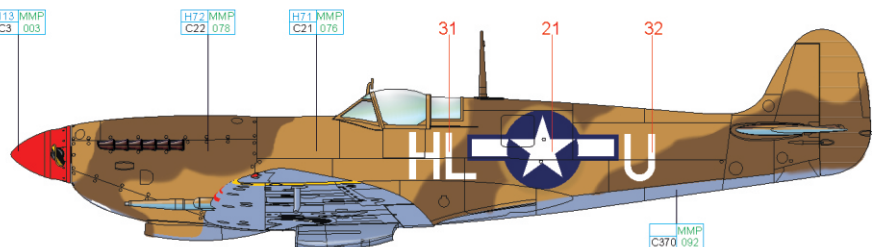

ČESKOU VERZI TEXTU NALEZNETE NA  
[www.eduard.cz](http://www.eduard.cz)  
 POD KATALOGOVÝM ČÍSLEM 70129

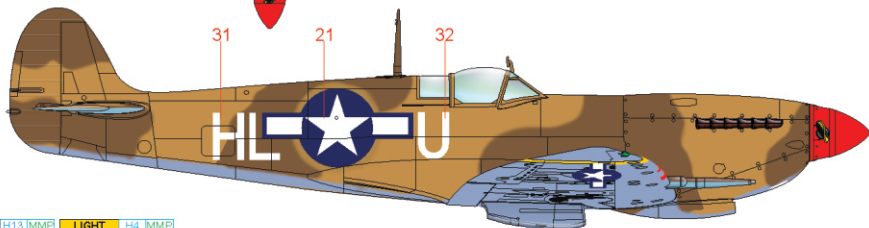
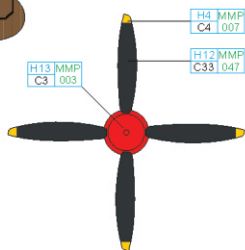
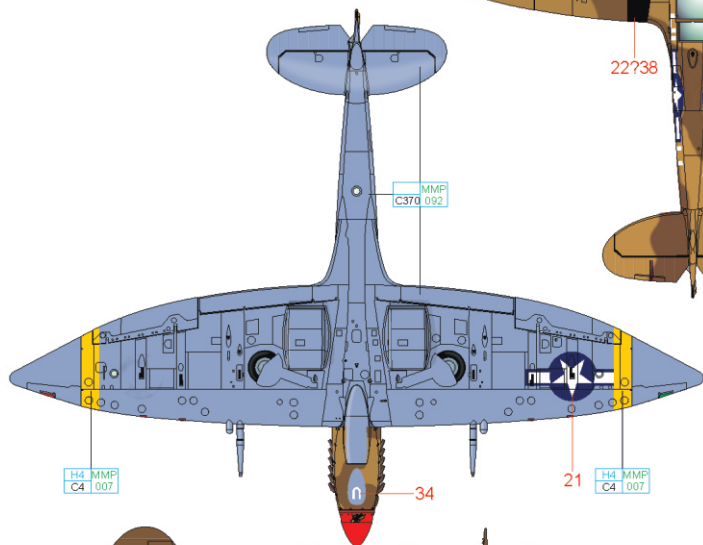
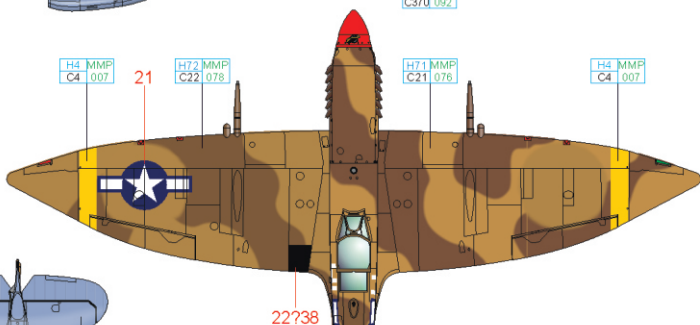

|       |                |              |                  |
|-------|----------------|--------------|------------------|
| RED   | H13 MMP C3 003 | LIGHT YELLOW | H4 MMP C4 007    |
| AZURE | MMP C370 092   | MIDDLE STONE | H71 MMP C21 076  |
|       |                | DARK EARTH   | H72 MMP C22 078  |
|       |                | BLACK        | H12 MMP C331 047 |



## RELATED PRODUCTS:

- 72645 Spitfire Mk.VIII 1/72 Eduard (PE-Set)
- 72646 Spitfire Mk.VIII landing flaps 1/72 (PE-Set)
- 73036 Seatbelts RAF early STEEL 1/72 (PE-Set)
- SS581 Seatbelts RAF early STEEL 1/72 (PE-Set)
- +672146 Spitfire Mk.VIII wheels - 4 spoke w/ smooth tire 1/72 (Brassin)
- 672147 Spitfire Mk.VIII wheels - 4 spoke w/ pattern 1/72 (Brassin)
- 672154 Spitfire Mk.VIII gun bays 1/72 (Brassin)
- 672155 Spitfire Mk.VIII top cowl 1/72 (Brassin)
- 672156 Spitfire Mk.VIII cockpit 1/72 (Brassin)

**eduard**

