



## H.M.S. COSSACK

The Cossack was one of the famous "Tribal" class of destroyers, built for the Royal Navy between 1938 and 1939. All sixteen of the Tribal class destroyers were in service by the outbreak of the Second World War, and all saw heavy service, only four of the original sixteen surviving the war. At the time of their launching the largest destroyers to be built for the Royal Navy, modified ships of this class are still employed by the Royal Canadian and Royal Australian Navies.

H.M.S. Cossack was built by Vickers-Armstrong and completed in June, 1938. In February, 1940, the Cossack was one of a patrol operating off the Norwegian coast when she received a report that the German tanker, the "Altmark," had been sighted. The Cossack pursued the "Altmark" into an ice-covered fiord, and a boarding party captured the German ship, liberating 299 British Merchant Seamen who were held prisoner on board.

Soon after, in April, 1940, the Cossack took part in the second battle of Narvik and received heavy damage, despite which, she and the Eskimo were able to regain port. In May, 1941, the Cossack was once again in action, this time in the famous action against the "Bismarck." Together with other destroyers the Cossack attacked the "Bismarck," preparing the way for her eventual sinking by torpedo.

The Cossack herself was sunk off Gibraltar on the 27th October 1941, after being torpedoed by a "U" boat.

The Cossack was 379 ft. overall and had a displacement of 1,870 tons. Armament consisted of eight 4.7 in. guns, one four-barrel 2-pounder "pom-pom," two 0.5 in. multiple machine guns and four 21 in. torpedo tubes. Total power was 44,000 S.H.P., giving a maximum speed of 36.5 knots.

The other ships of the Tribal class were the Afridi, Bedouin, Ghurka, Maori, Mashona, Matabele, Mohawk, Punjabi, Somali, Sikh, Zulu, Ashanti, Eskimo, Nubian and Tartar, only the last four named surviving the war.

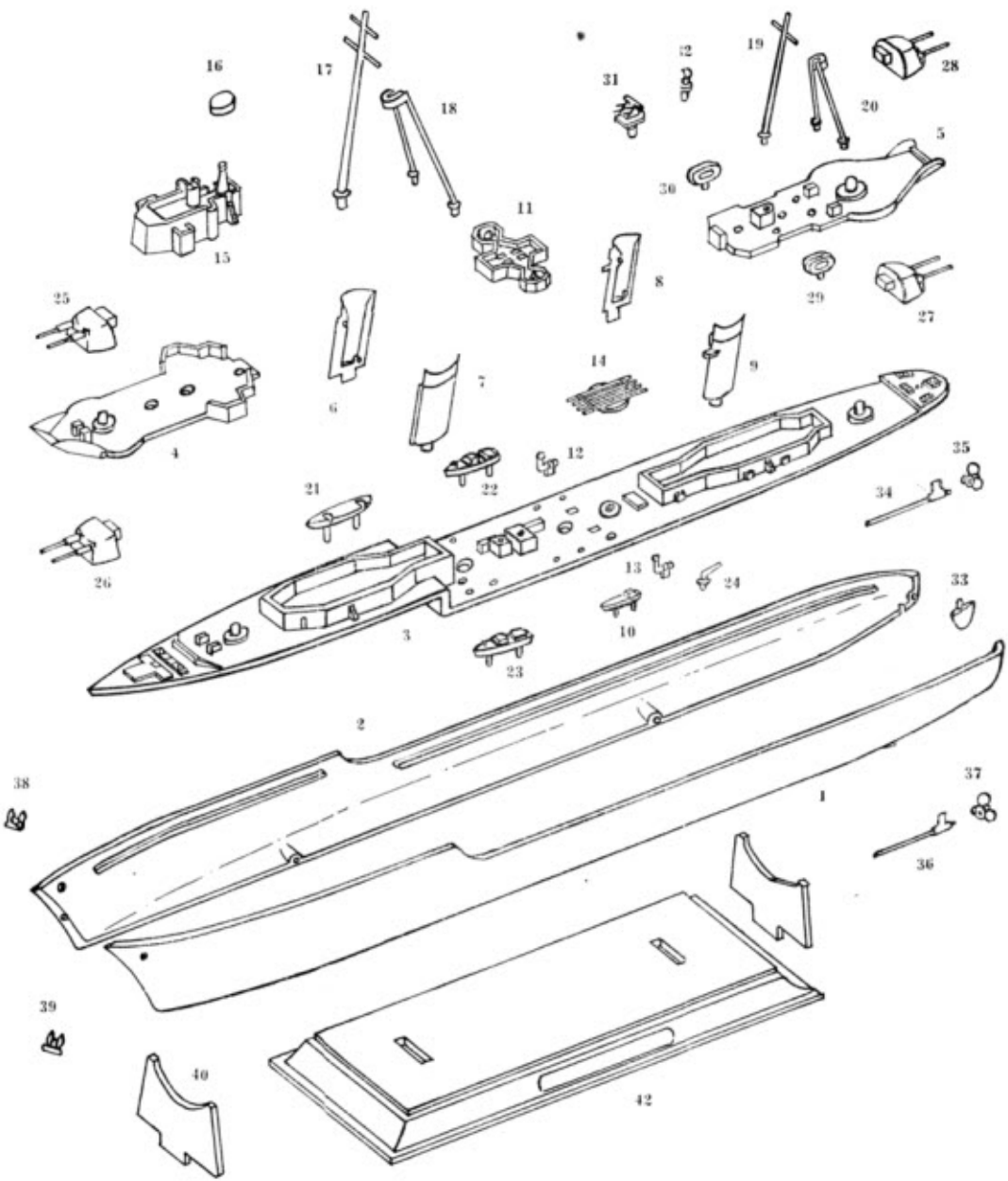

## INSTRUCTIONS

It is recommended that the instructions and exploded view are studied before assembly. If it is wished to paint such small parts as lifeboats or rafts, this is best done before assembly.

1. Locate and cement together hull sides, applying cement to inside of hull (1 & 2).
  2. Apply cement to locating strips at top of hull and set deck in place (3).
  3. Locate and cement in position gun decks on fore and aft superstructure (4 & 5).
  4. Cement together halves of fore and aft funnels, and cement completed funnels into locating holes, immediately fore and aft of central island superstructure (6—9).
  5. Cement motor dinghy (smallest boat) into locating holes on port side (10).
  6. Locate and cement central deck in position on central superstructure (11).
  7. Cement ventilators into locating slots on either side of aft funnel (12 & 13).
  8. Press pivot pin of torpedo tubes into locating hole behind aft funnel (14).
  9. Locate and cement upper superstructure on to forward gun deck, and cement range-finder platform on to locating pin (15 & 16).
  10. Cement foremast into locating hole aft of forward superstructure, ensuring mast is correctly angled back, place brace over front of mast, then cement into locating holes on either side of funnel, and at crew's nest where it surrounds foremast (17 & 18).
  11. Similarly locate and cement main mast to aft gun deck, correctly raked back, locate and cement brace in position, in this case locating centre piece behind mast (19 & 20).
  12. Locate and cement whaler and motor launch to starboard side of deck, and motor launch to port side, ensuring davits are facing inward (21, 22 & 23).
  13. Cement torpedo davit into locating hole, immediately aft of dinghy (24).
  14. Press gun turrets on to projecting pins on main and gun decks (25—28).
  15. Cement Carley floats on to locating holes on either side of after control platform (29 & 30).
  16. Locate and cement multiple pom-pom into locating hole forward of control platform, and locate and cement searchlight in top of platform (31 & 32).
  17. Cement rudder in locating hole below stern (33).
  18. Cement propellers on to propeller shafts and cement shafts into locations on either side of after hull (34—37).
  19. Locate and cement anchors into holes on either side of bows (38 & 39).
- NOTE.—If it is wished to paint the model it should be done at this stage.
20. Apply turrets, first cut the sheet into five separate subjects. Then dip each in warm water for a few minutes, slide off backing into position as shown on illustration. The identification numbers are applied to either side of the forward hull, between the two rows of portholes, and to the stern. The black band is applied around the top of the forward funnel, and the ship's name to the base platform.
  21. Assemble stand. Cement the two cradles into the slots of the base platform, and cement completed model on to stand.

### SUGGESTED COLOUR SCHEME

<b>Battleship Grey:</b>	All superstructure, turrets, hull above water line.
<b>Black:</b>	Hull below water line.
<b>Bronze:</b>	Anchors and propellers.
<b>Dark Grey Green:</b>	Main and gun decks.

N.B.—For Painting use AIRFIX Paints.

For Fixing use AIRFIX Polystyrene Cement.

All Airfix Famous Warship Construction Kits are made to a constant 1 in. to 50 ft. (1/600) scale. All models are designed with the same skill and attention to detail so that a large and varied collection can be built up. Each model is true to scale and realistic in relationship to all other models. Other fine Airfix Construction Kits are available in various scales, such as Historical Ships, 1/72 Aircraft, 1/32 Vintage Cars, 00 Trackside Houses and Accessories, and 1/12 Model Figures. A list of the many other Airfix Models which you can make will be found on a slip in this package.