

BEECH AT-11

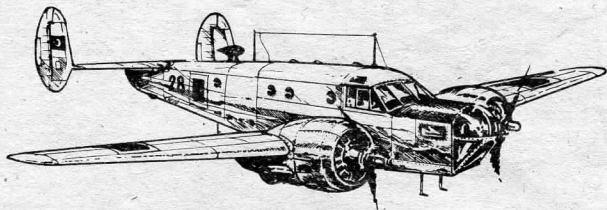

HISTORY OF THE AT-11

Following the very successful production of the Beech C-45 series (Pioneer Kit No. 4003), another version of the Beech Model 18 appeared in 1941 designated as the AT-11 Kansan (formerly, Kansas) and procured by the USAAF as a bombing and gunnery trainer (the "AT" standing for "Advanced Trainer").

This aircraft incorporated a small bomb bay, had circular portholes in place of the usual rectangular cabin windows and was very easily recognised from the C-45s by the transparent nose on the modified fuselage. It also sported a 0.3" machine gun in the nose and another in the dorsal turret (when fitted).

The USAAF purchased 1582 aircraft of which 36 were converted to AT-11A standard for navigational training. 24 aircraft were ordered by Holland for service in the Dutch East Indies, although they were actually taken on board by the USAAF who finally delivered them to the Royal Netherlands Flying School in Jackson Mississippi in 1942.

During the early fifties, many T-11 aircraft were remanufactured to zero time for the USAF and were subsequently re-identified as C-45Hs.

Engines:	Two Pratt & Whitney R-985-AN-1
Speed:	Maximum at 5000' (1500m) is 215mph (344kph)
Ceiling:	Service 20000' (6100m)
Range:	870 miles (1390kms) at a cruising speed of 142mph (227kph)



GLUE



DO NOT
GLUE



OPTIONAL
CHOICE

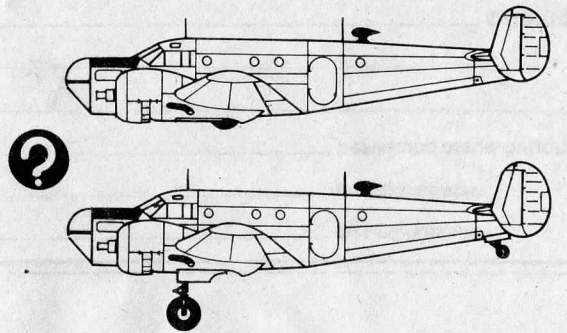
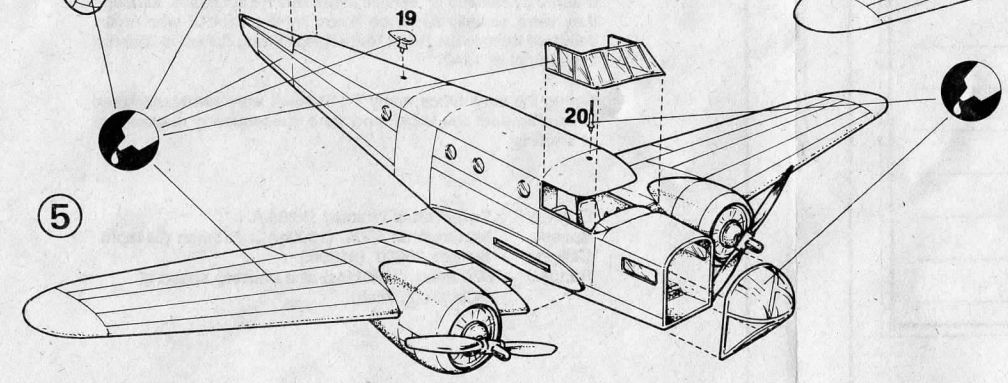
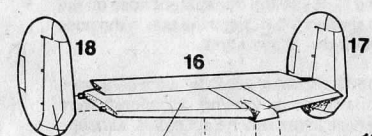
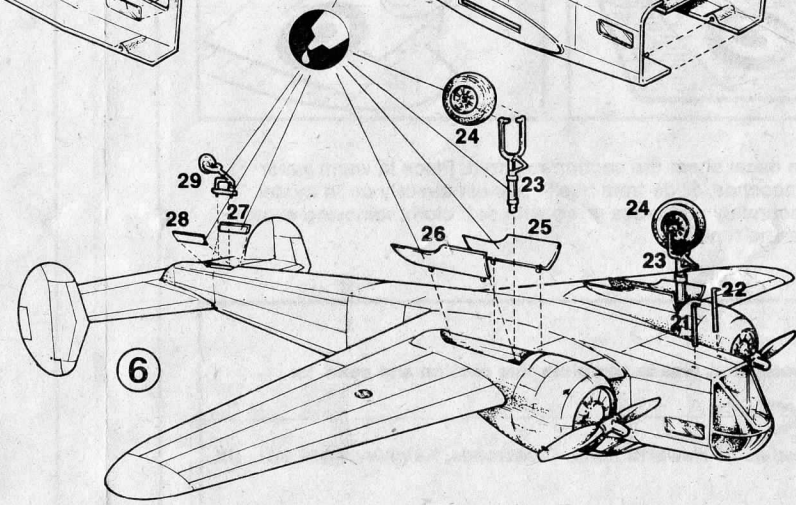
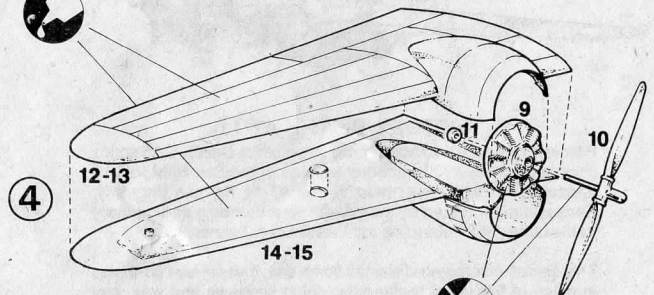
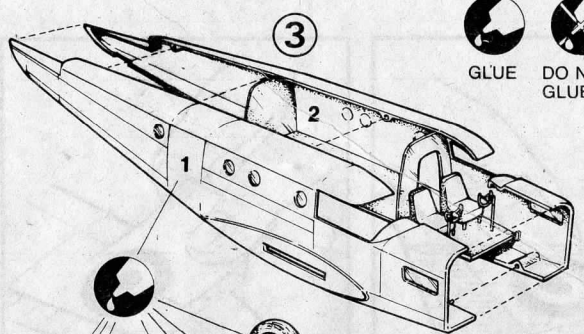
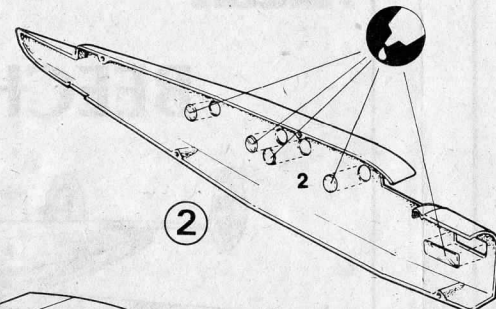
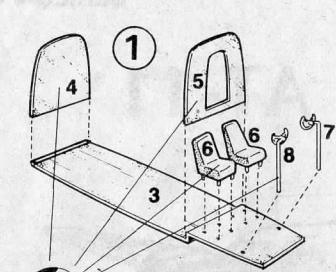

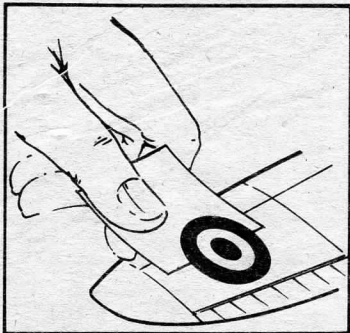
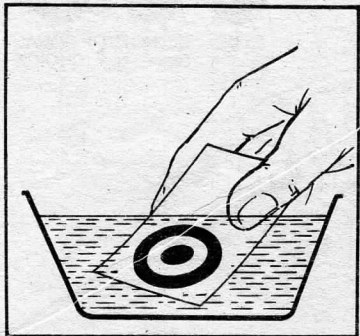

"Cut from decal sheet the section required. Place in warm water for 10-15 seconds. Slide from backing sheet directly on to model. Locate accurately and press down with soft cloth, removing excess water at same time."

In case of complaint please complete this section and send to:



Pioneer 2 Models 46 Haworth Road, Crossroads, Keighley, BD22 9DL, UK.

NAME _____

ADDRESS _____

Quoting where purchased _____

date purchased _____

missing part no _____