

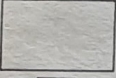

Fiat G. 91 R.3 Le.KG 42, Büchel 1975



RAL 7001



LK

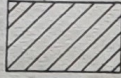

MK

RAL 6014



JK

RAL 7012



KK

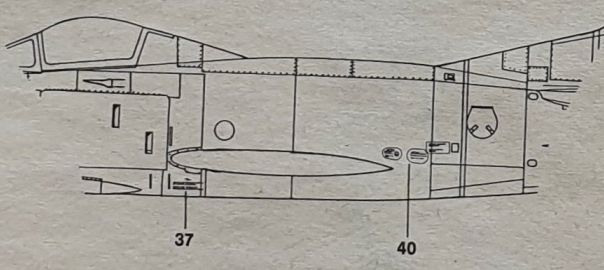
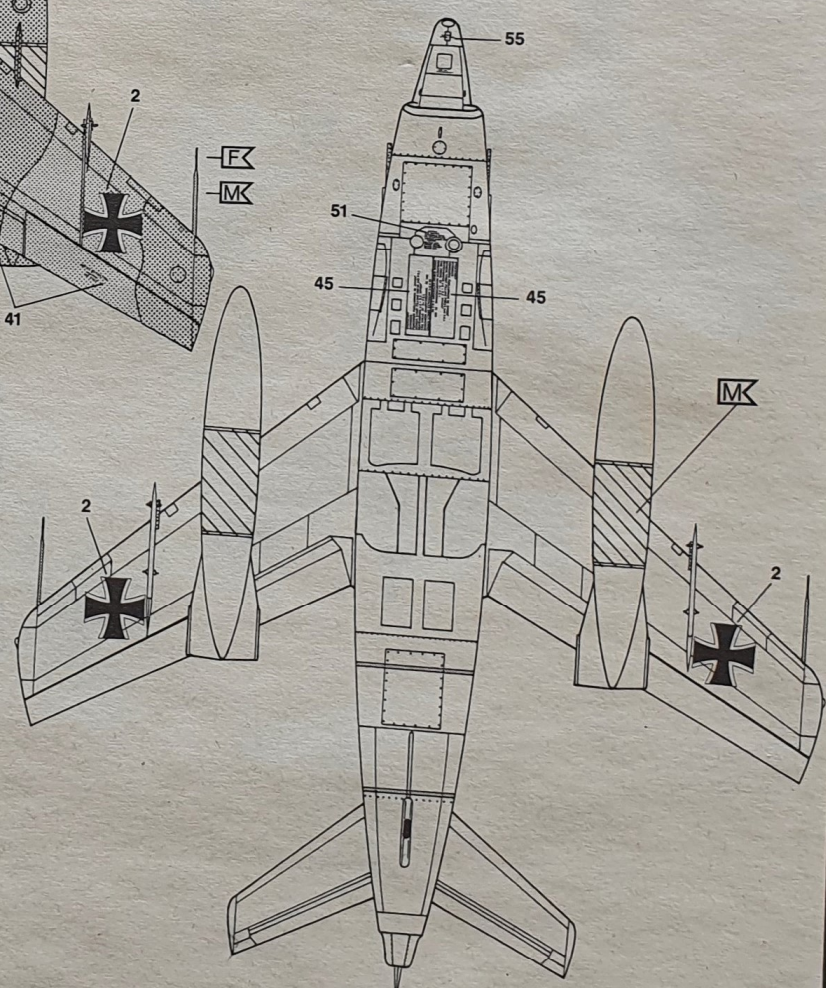
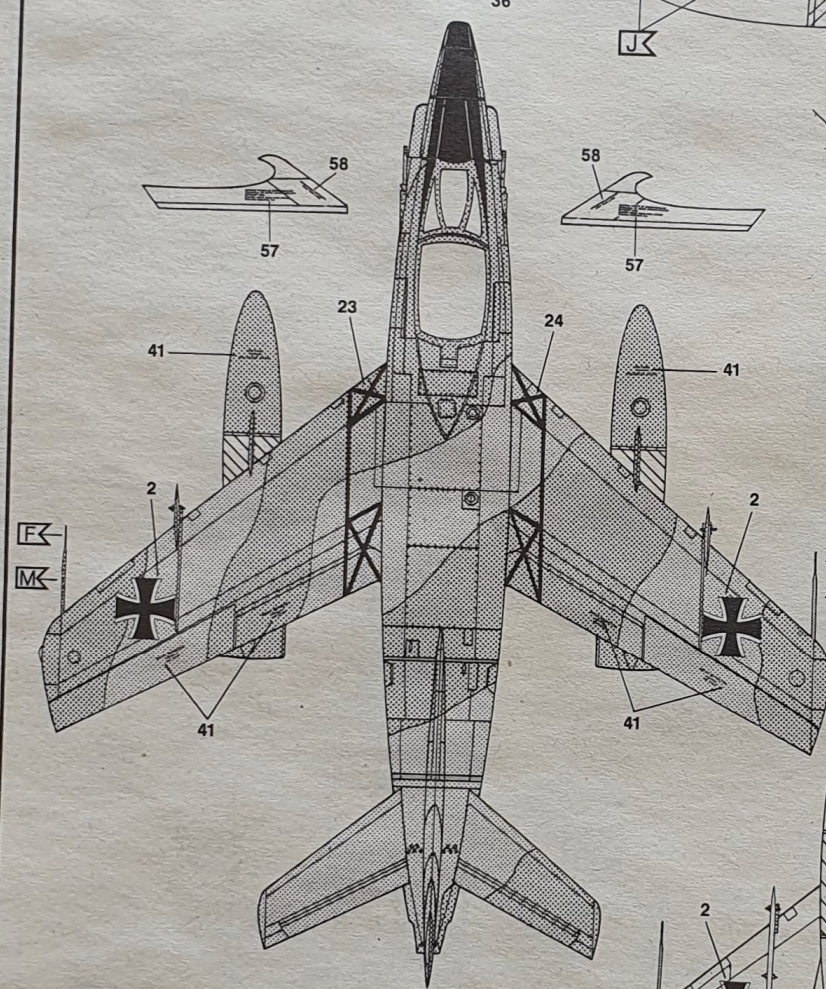
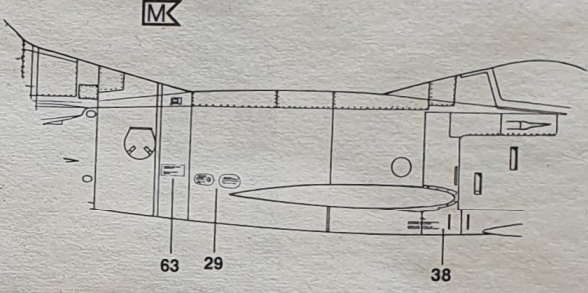
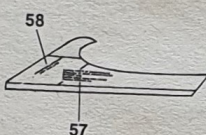
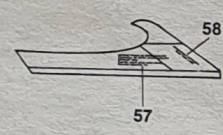
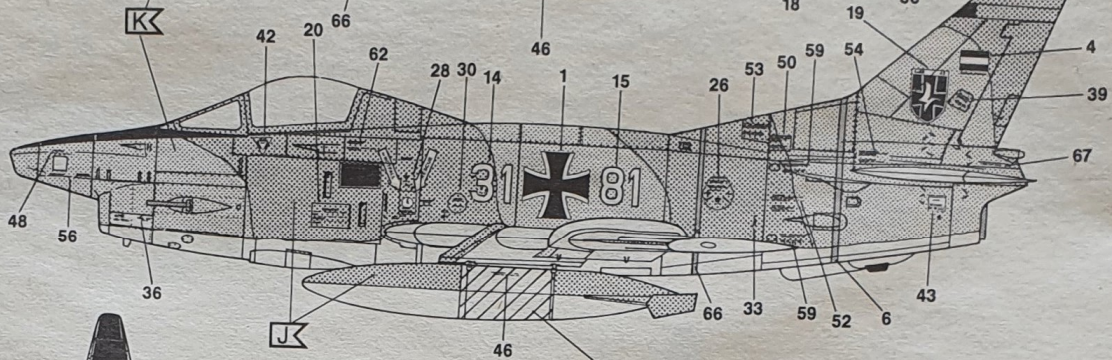
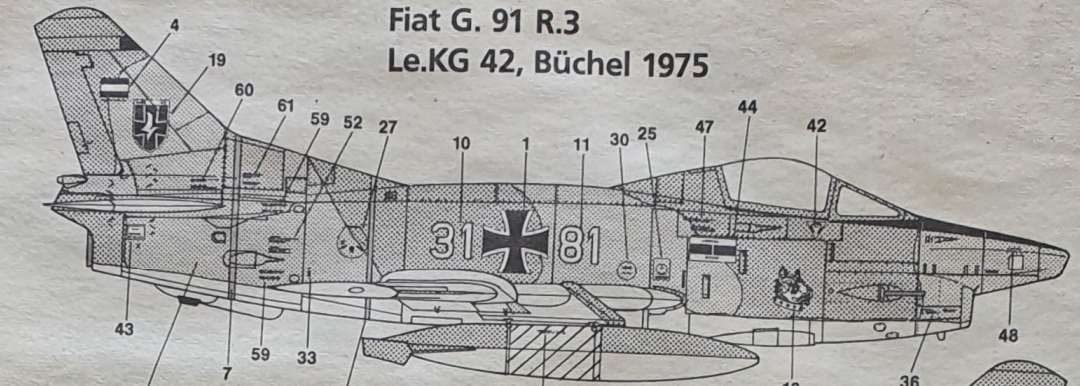



Fiat G. 91

Die Fiat G. 91 ist ein kleines, leichtes Erdkampfflugzeug für kurze Start- und Landestrecken und flog am 9. August 1956 erstmals. Die Luftwaffe stellte die G. 91 im Jahr 1961 in Dienst. Inklusiv der deutschen Lizenzfertigung wurden 294 Maschinen der Version R3 (mit zwei 30 mm Kanonen DEFA 552) gebaut. Für weitere Bewaffnungen waren nur noch 454 kg vorgesehen. Das normale Fluggewicht betrug 5.330 kg, dies zeigt deutlich, wie klein das Flugzeug eigentlich war. Heutige Jets tragen alleine schon mehr Sprit als das damalige Gesamtgewicht der Fiat. Die Höchstgeschwindigkeit von 1045 km/h wurde durch das Fiat (Bristol Siddeley) Orpheus 803 Triebwerk ermöglicht. Dieses erbrachte respektable 2.270 kp Schub, der das Flugzeug in 7,30 min auf 8.000 m Höhe bei einer Anfangs-Steiggeschwindigkeit von 30 m pro Sekunde katapultierte. Leider konnten diese Werte nur durch einen sehr geringen Aktionsradius von 315 – 560 km erbracht werden. Die außerordentliche Agilität spiegelte sich auch im Umbau von 16 Fiat zur G. 91 PAN wieder, die exklusiv für den Einsatz als Kunstflugstaffel genutzt wurden.

Fiat G. 91

The Fiat G. 91 is a small, light, ground-attack aircraft for short take-off and landing strips that flew for the first time on 9th August 1956. The Luftwaffe put the G. 91 into service in 1961. 294 of the R3 version (with two 30 mm DEFA 552 cannon were built, including German manufacture under licence). Only 454 kg capacity was available for further armament. The normal flying weight was 5,330 kg, which clearly shows how small the aircraft itself was. Present-day jets carry more fuel alone than the then all-up weight of the Fiat. The Fiat (Bristol Siddeley) Orpheus 803 engine gave the aircraft a max. speed of 1045 km/h. This gave it a respectable 2,270 kp thrust that catapulted it to 8,000 m in 7 min. and 30 seconds from an initial rate of climb of 30 m per second. Unfortunately these figures could only be achieved within a very small radius of action of 315-560 km. The extraordinary agility of the Fiat was also reflected in the conversion of 16 of them to the G. 91 PAN for the exclusive use of the aerobatics squadron.

Form hergestellt und im Eigentum von Revell AG/Revell Monogram Inc. Widerrechtliche Nachahmungen werden gerichtlich verfolgt.
 Ce produit est propriété de la société Revell AG/Revell Monogram Inc. Toute utilisation ou duplication frauduleuse fera l'objet de poursuites en justice.
 Modelado y en propiedad de Revell AG/Revell Monogram Inc. Imitaciones ilícitas serán perseguidas por la ley.
 Forma prodotta dalla Revell AG/Revell Monogram Inc. e di proprietà della stessa impresa, la quale procederà legalmente contro ogni imitazione abusiva.
 Malli on Revell AG/Revell Monogram Inc. valmistama ja omaisuutta. Laittoman kopiointiin tullaan puuttamaan oikeudellisin toimin.
 Formen er produsert og eies av Revell AG/Revell Monogram Inc. Etterligning uten tillatelse vil bli gjenstand for rettslig forfølgelse.
 Produkcja i prawa własności firmy Revell AG/Revell Monogram Inc. Nielegalne podrobienie jest zabronione pod odpowiedzialnością sądową.
 Model, Revell AG/Revell Monogram Inc. firmasının mülkiyeti altında imal edilmiştir. Kanuna aykırı taklitler mahkemece takip edilecektir.
 A forma előállításja és a tulajdonjog birtokosa a Revell AG/Revell Monogram Inc. A jogellenes utánzatokat és hamisítványokat bíróságlag üldözik.

Mould manufactured by and property of Revell AG/Revell Monogram Inc. Illegal imitations are subject to prosecution.
 Vorm vervaardigd door en eigendom van Revell AG/Revell Monogram Inc. Onrechtmatige nabootsingen worden gerechtelijk vervolgd.
 Formas produzidas e de propriedade da Revell SA/Revell Monogram Inc. Cópias não autorizadas serão processadas juridicamente como determinado na lei.
 Modellerna tillverkad av och tillhör Revell AG/Revell Monogram Inc. All kopiering beivras enligt lagen om upphovsrätt.
 Formen er fremstillet af Revell AG/Revell Monogram Inc. som også har ejendomsret. Lovstridige efterligninger sagsøges.
 Modelь изготовлена и является собственностью фирмы Revell AG/Revell Monogram Inc. Противозаконные подделки преследуются в судебном порядке.
 Η μορφή κατασκευάστηκε και περιήλθε στην ιδιοκτησία της Revell AG/Revell Monogram Inc. Οι παράνομες μιμήσεις θα καταδικαστούν δικαστικώς.
 Tvar byl vytvořen firmou Revell AG/Revell Monogram Inc. a je jejím vlastnictvím. Proti nezákonným napodobením se bude postupovat soudní cestou.
 Forma je proizvedena in je vlasništvo Revell AG/Revell Monogram Inc. Neovlaštene kopije bodo pravno kažnjene.

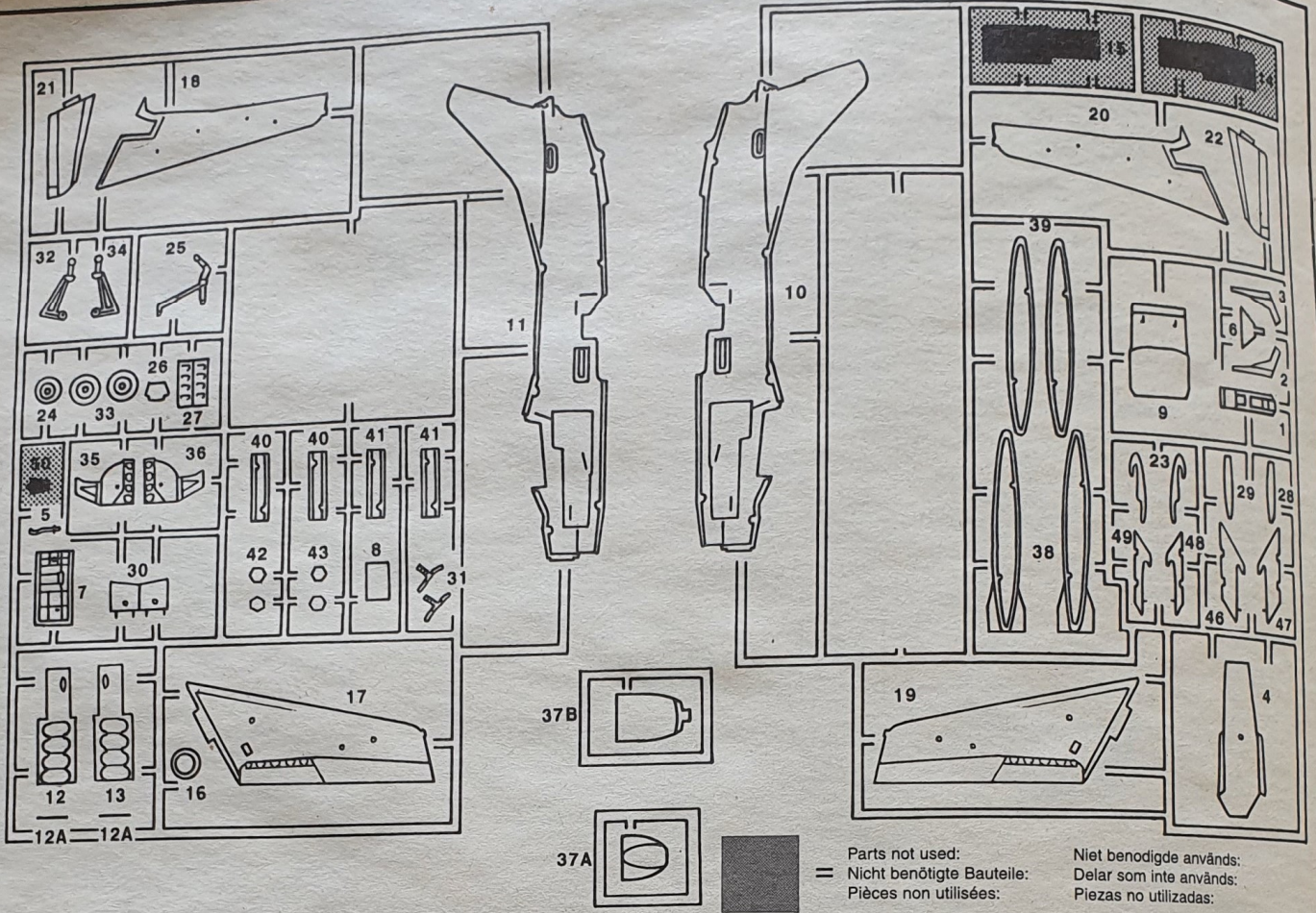

1

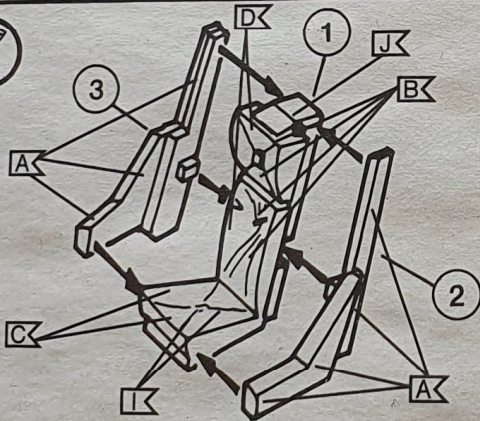

2

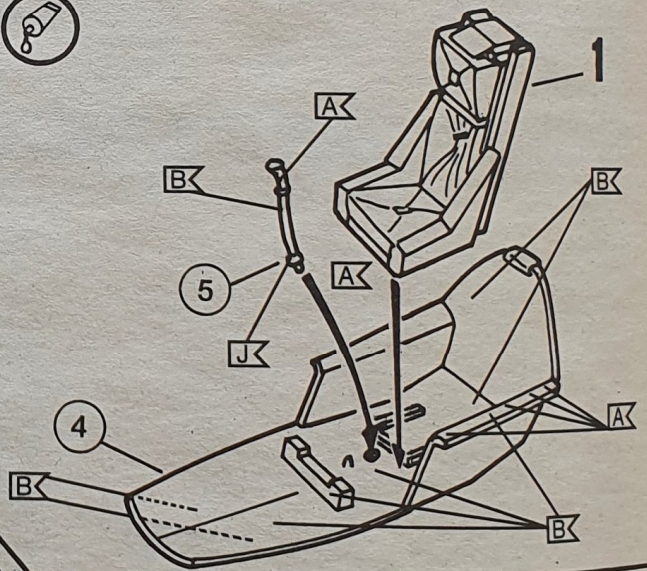

3

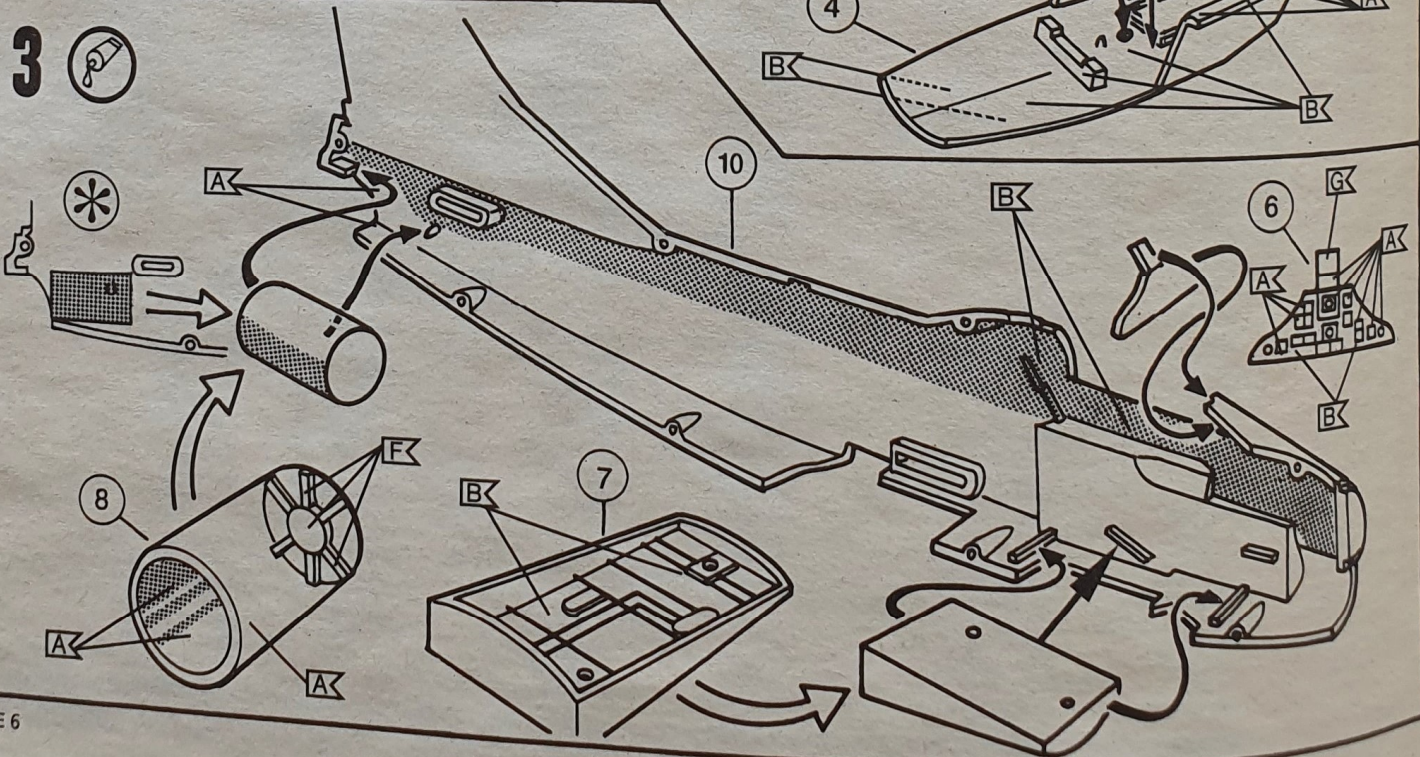

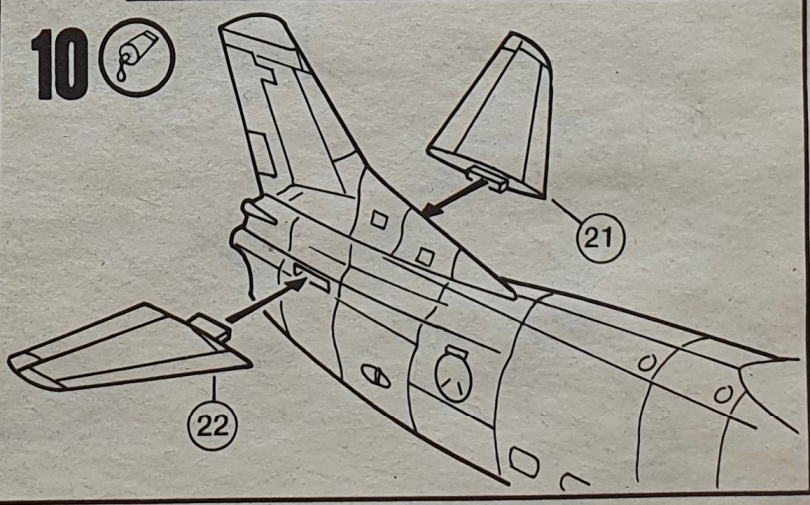
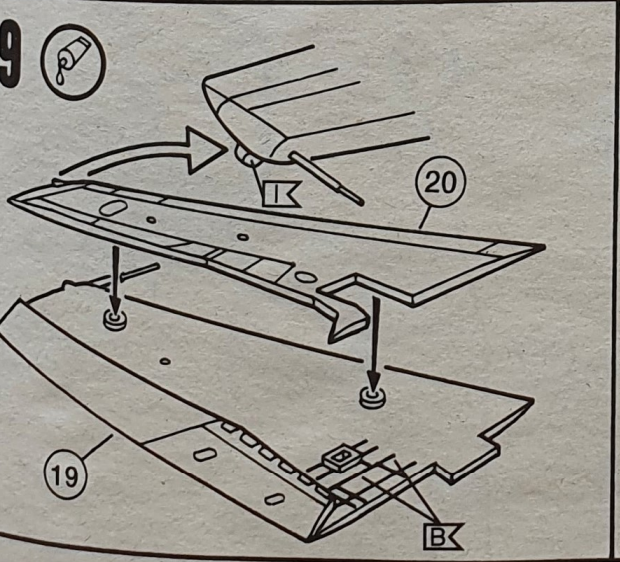
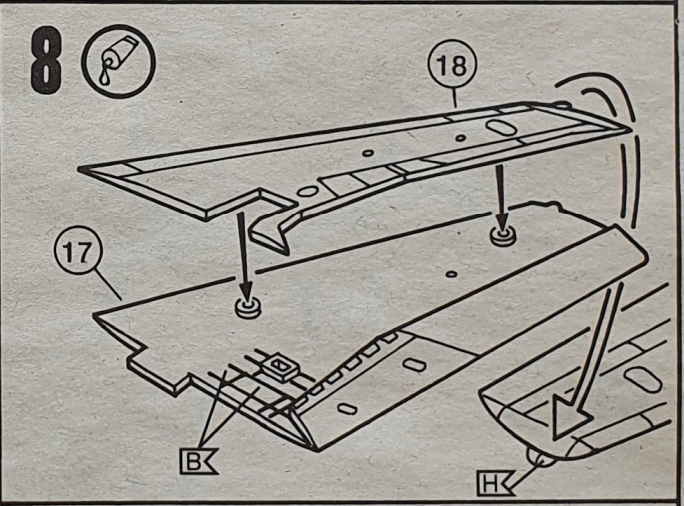
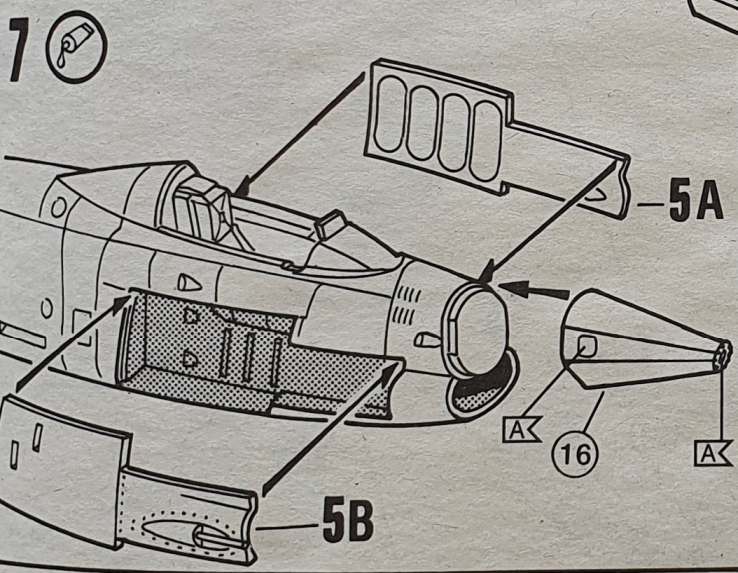
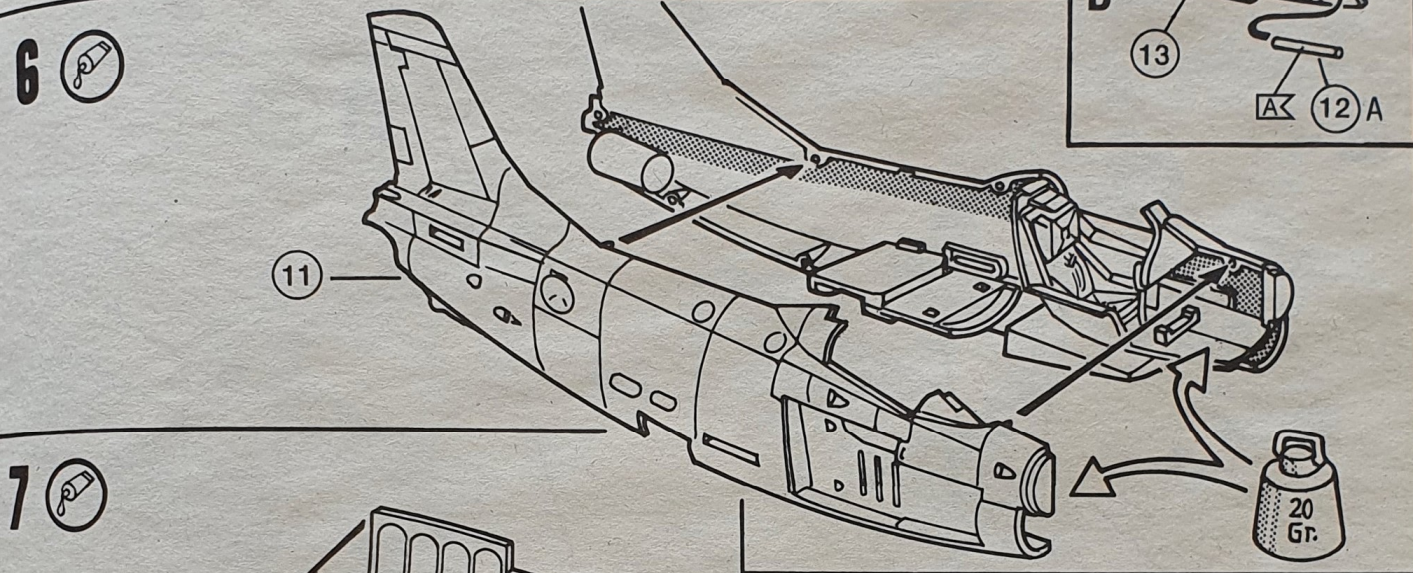
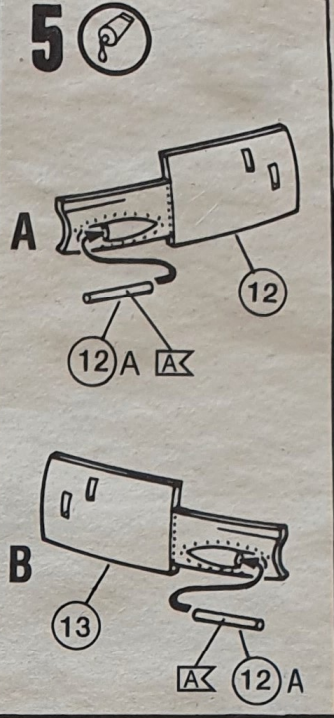
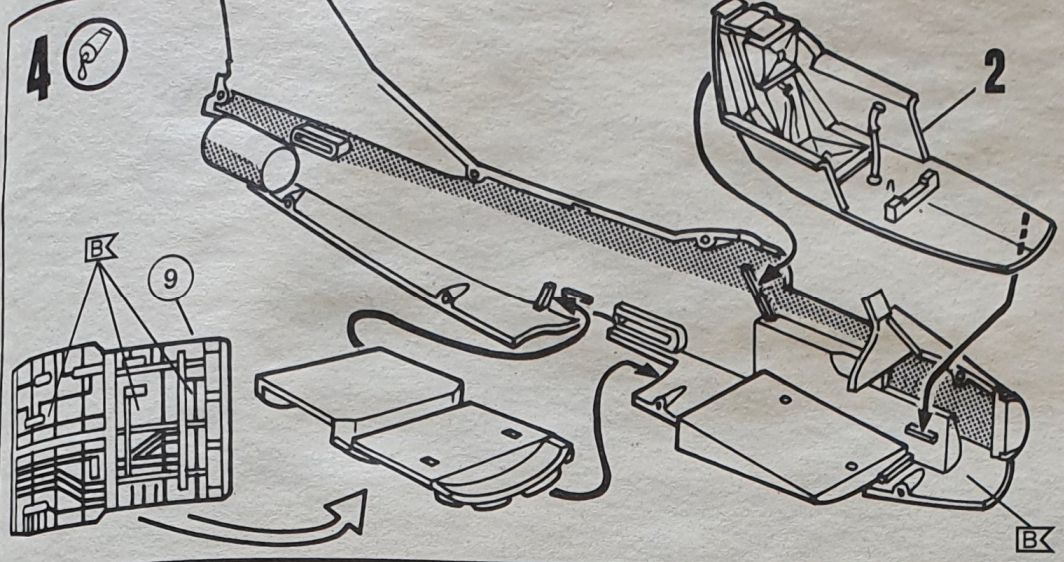

11

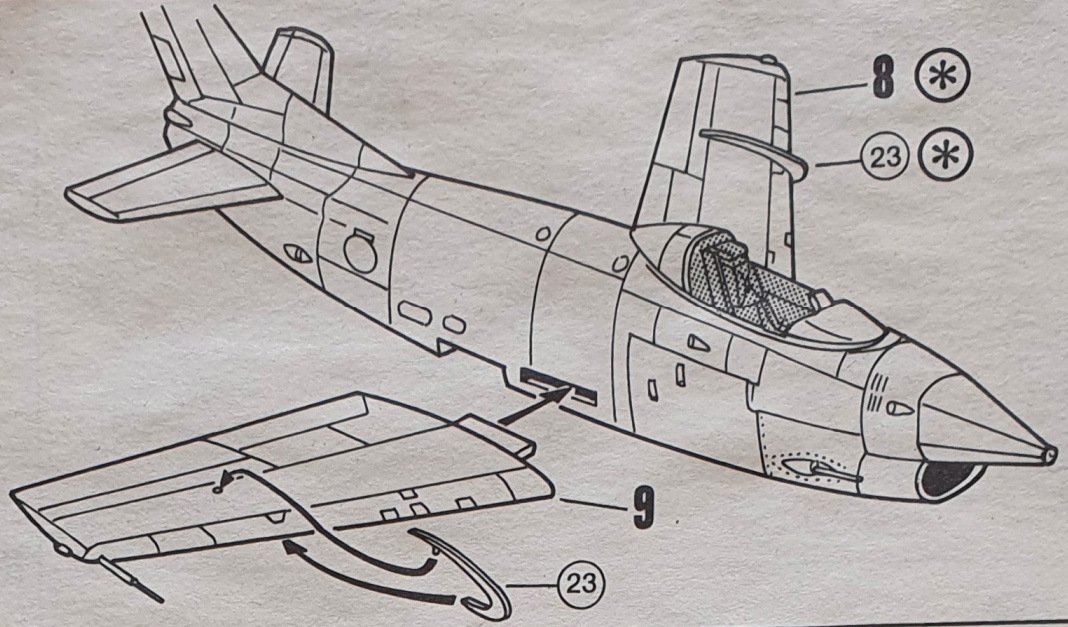

12

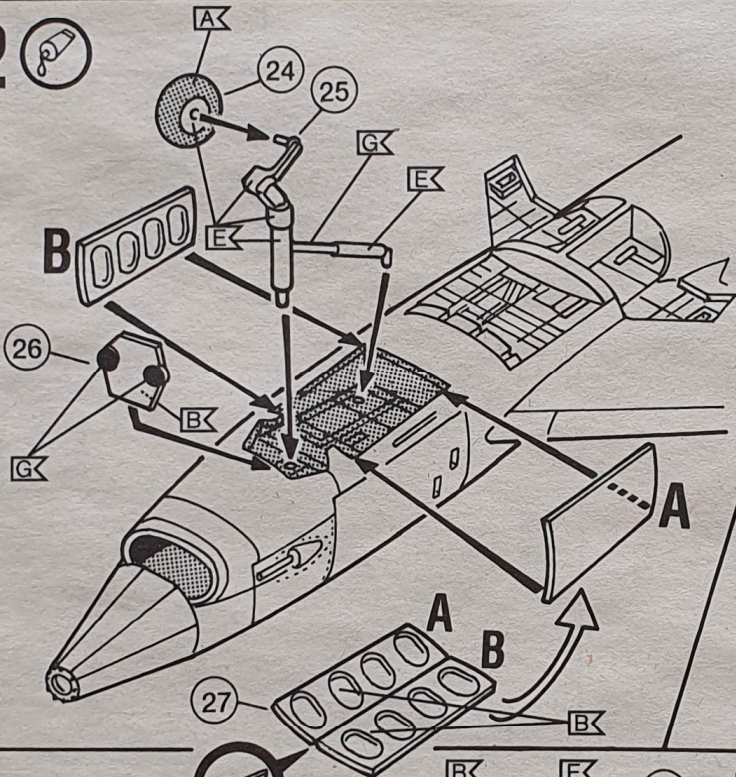

13

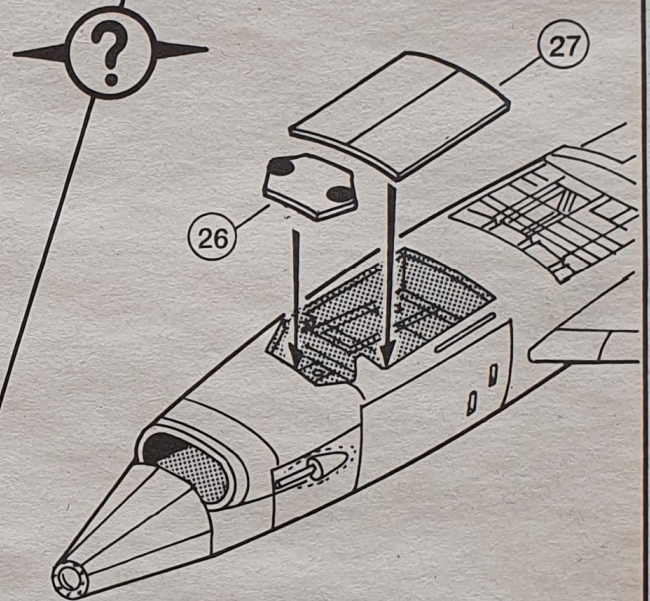

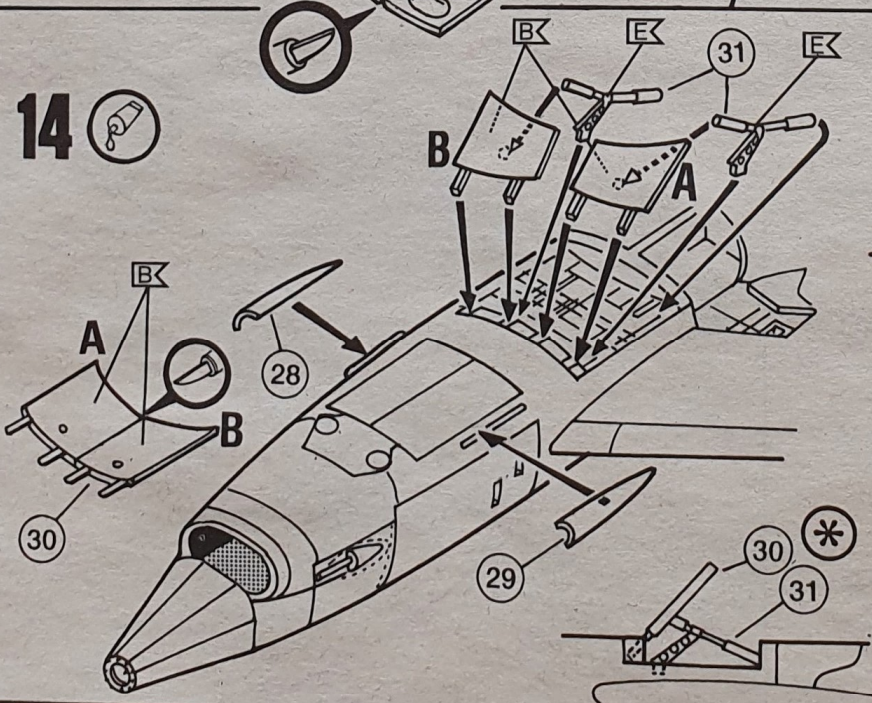

14

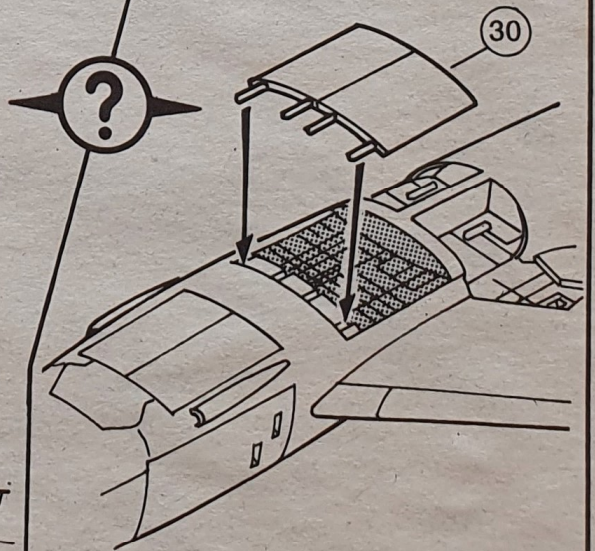

15

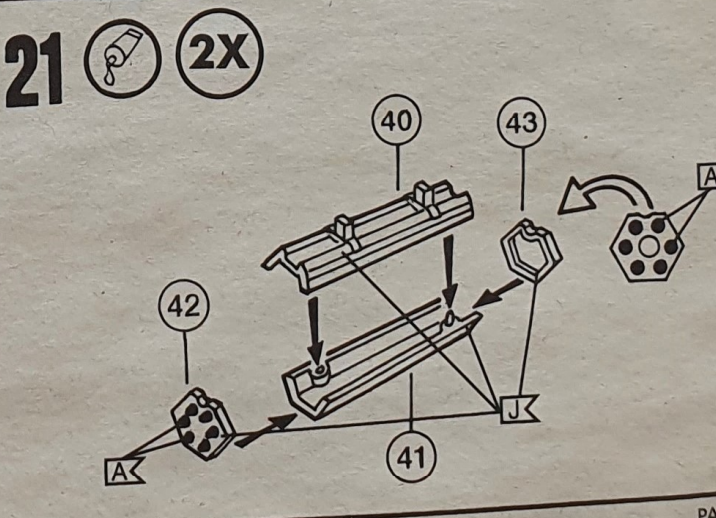
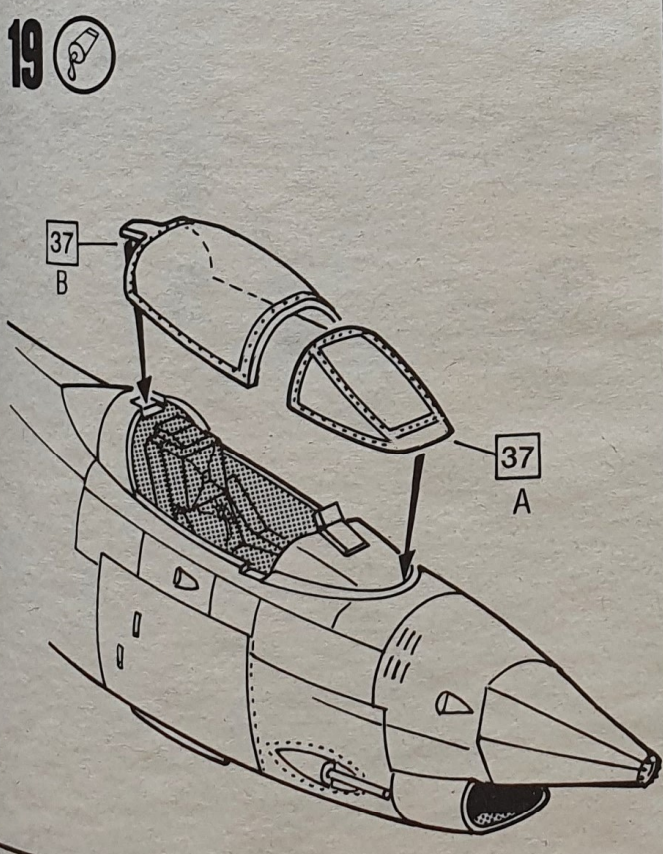
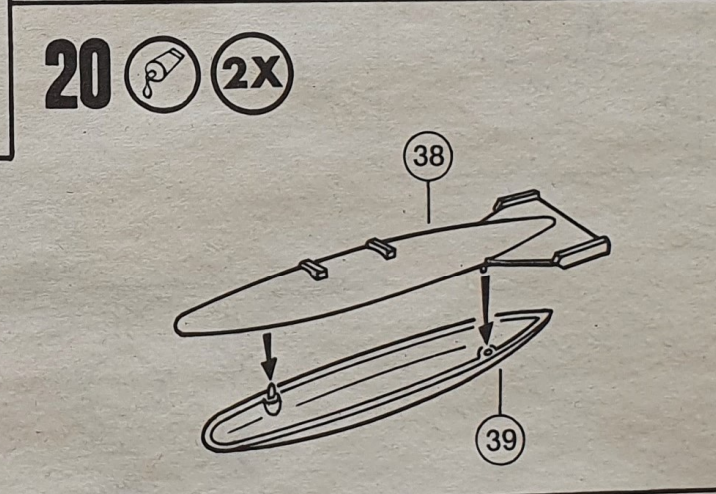
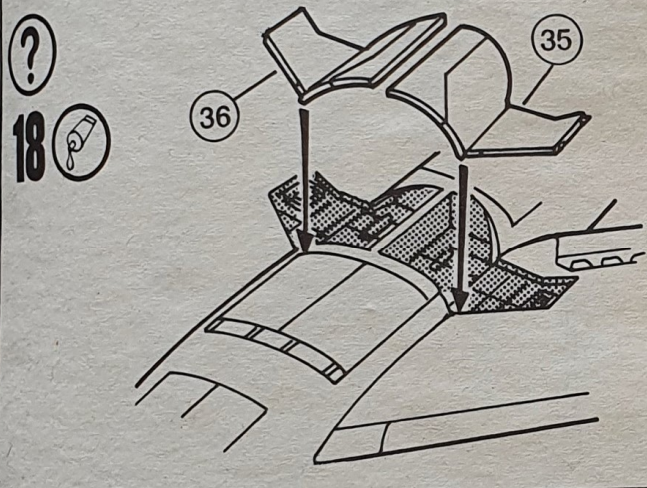
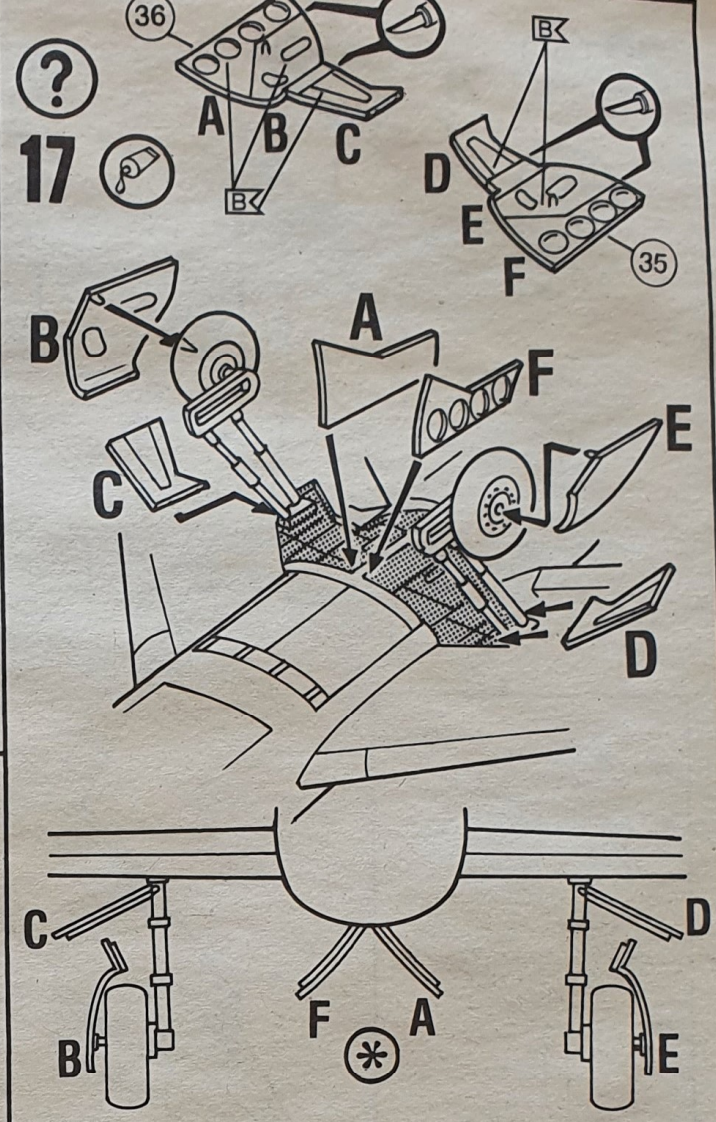
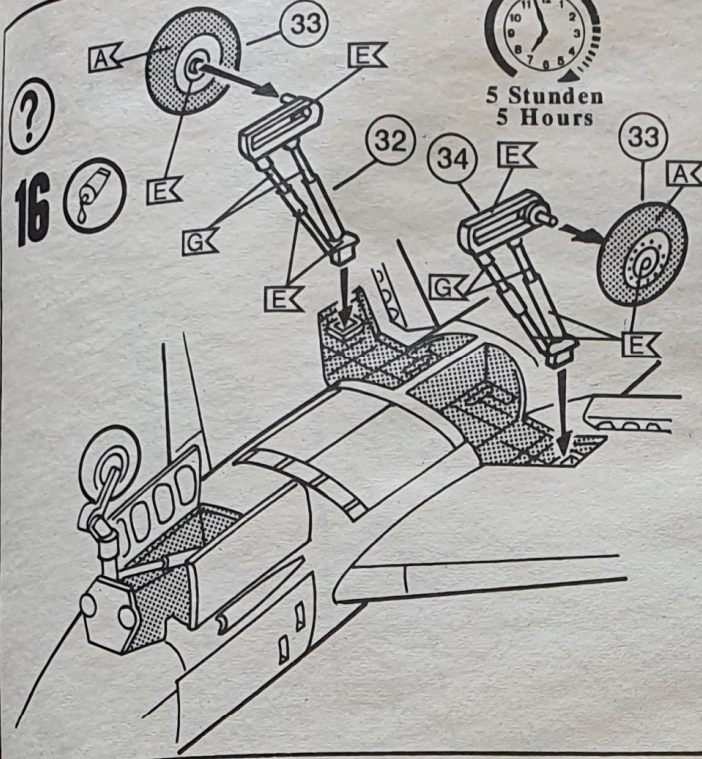



22 



5 Stunden
5 Hours

 23, 24

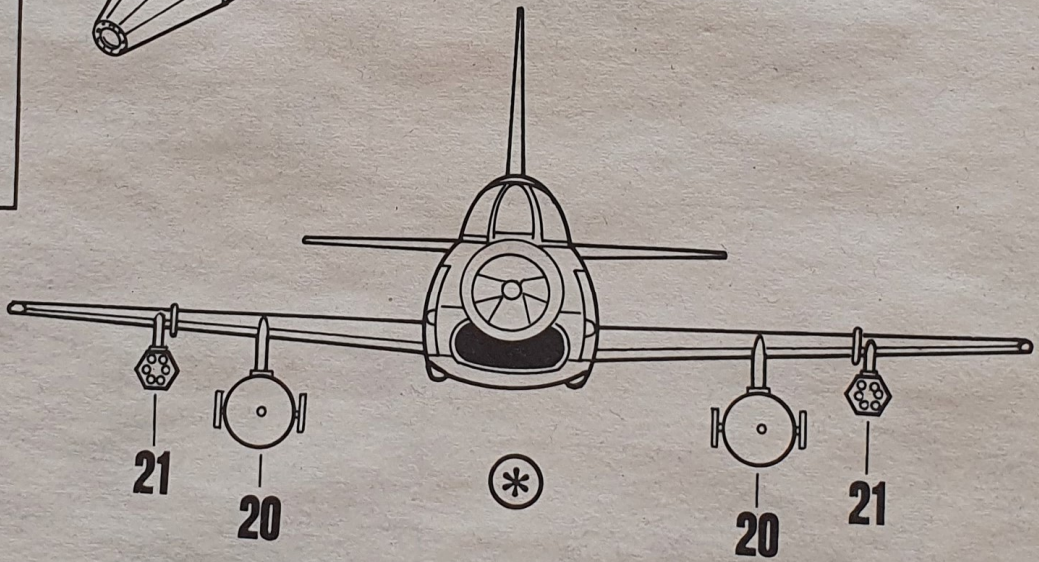
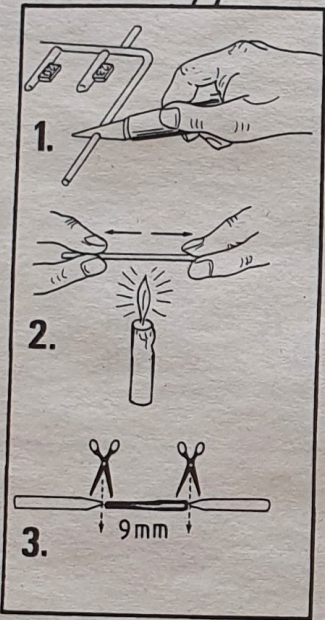
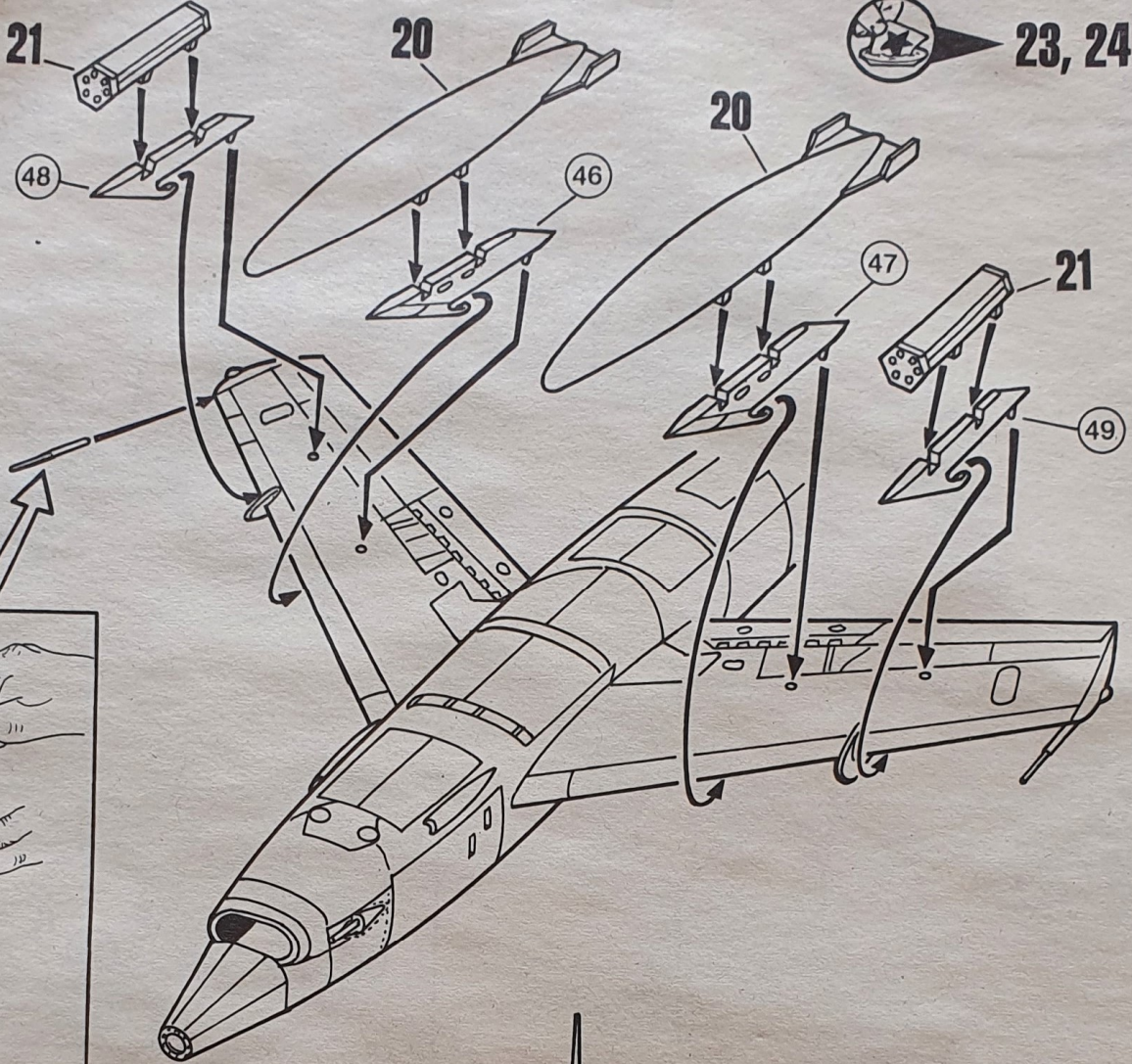



Fiat G. 91 R.3 Le.KG 41, Husum, Oktober 1979 „Bulls Eye 79“



RAL 7001

RAL 6014

RAL 7012

