

# 92096

# Lightning P-322 II

scale 1/72



The P-322 designation was used for aircraft taken over by the USAAF after the RAF cancelled an order for 667 P-38 Lightnings in 1942. This order had been inherited from the French, and had been for a simplified version of the aircraft, without the turbo-superchargers used by all USAAF P-38s.

Before receiving its first Lightnings, the RAF had changed its order to include 146 Lightning Mk Is, as ordered by the French, and 524 Mk IIs, which would have closely resembled the P-38E. The USAAF took over the British order, and completed the 524 Mk IIs as standard P-38Fs and P-38Gs.

The earlier aircraft was also taken over. Twenty two were completed as ordered, and given the designation P-322-I. The remaining 121 were given "F" series engines, as used in American P-38s, although they still lacked the turbo-supercharger. These aircraft were given the designation P-322-II. In American service these aircraft were used as advanced trainers, providing an ideal way to introduce new pilots to the P-38 without the added complexity of the turbo-supercharger for them to worry about.

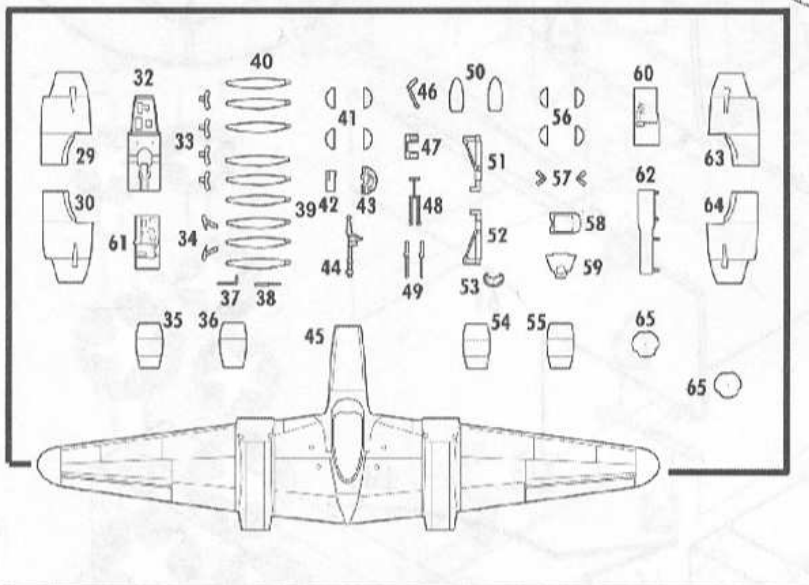
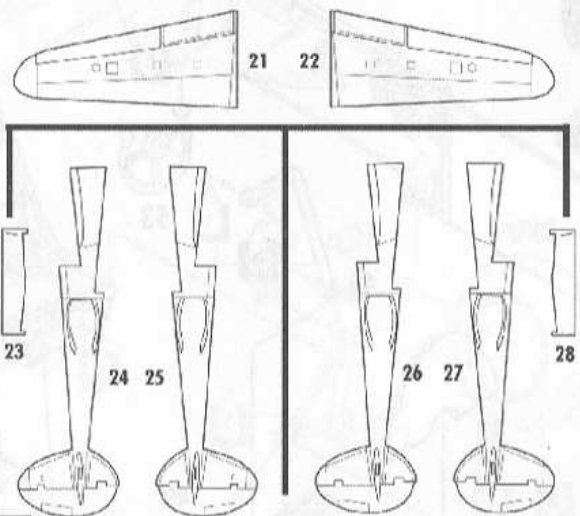
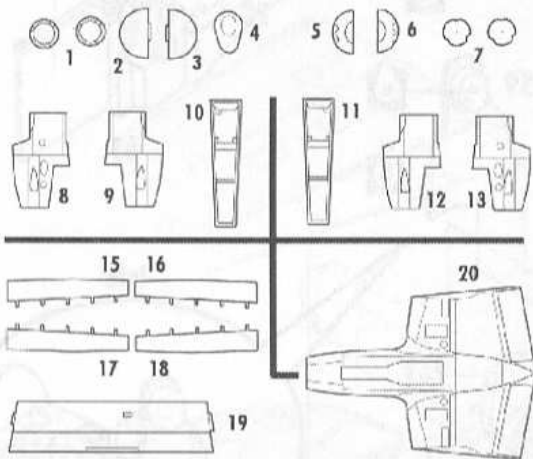

POLYURETHAN PARTS (PUR)

CLEAR PART (C)



COLORS

<b>a</b>	Černá Black	<b>h</b>	Červená Red
<b>b</b>	Interiér. Žlutá Zinc Chromate	<b>i</b>	Bílá White
<b>c</b>	Stříbrná Silver	<b>j</b>	Žlutá Yellow
<b>d</b>	Přílno Linen	<b>k</b>	Pneumatiky Tyres Black
<b>e</b>	Kůže Leather	<b>l</b>	Rezová Rust
<b>f</b>	Hliníková Aluminium	<b>m</b>	Tmavá šedá Dark Grey
<b>g</b>	Chromová Chrome	<b>n</b>	Kovová Gun metal

LEGEND

ohnout bend	višňové lepidlo cyanoacrylate glue	odstranit remove	upravit reduce	vrtat open hole	vyrbit sctrach build	(D) obtisk decal	barva color	(F) film

92096

STEP 1

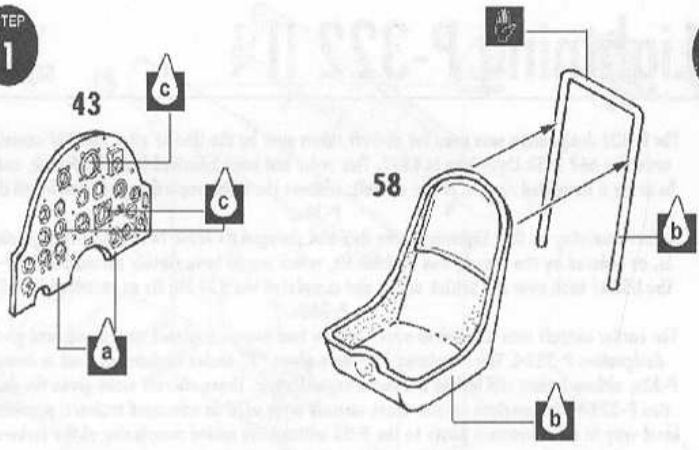

STEP 2

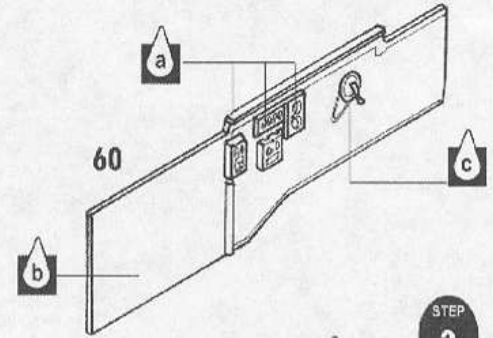

STEP 3

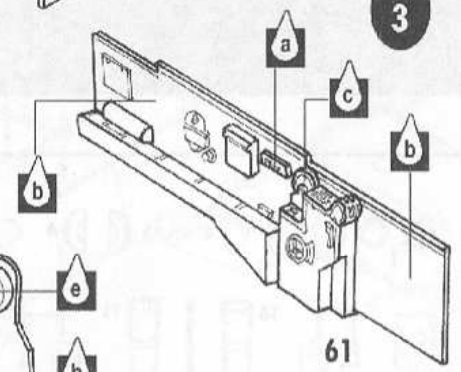

STEP 4

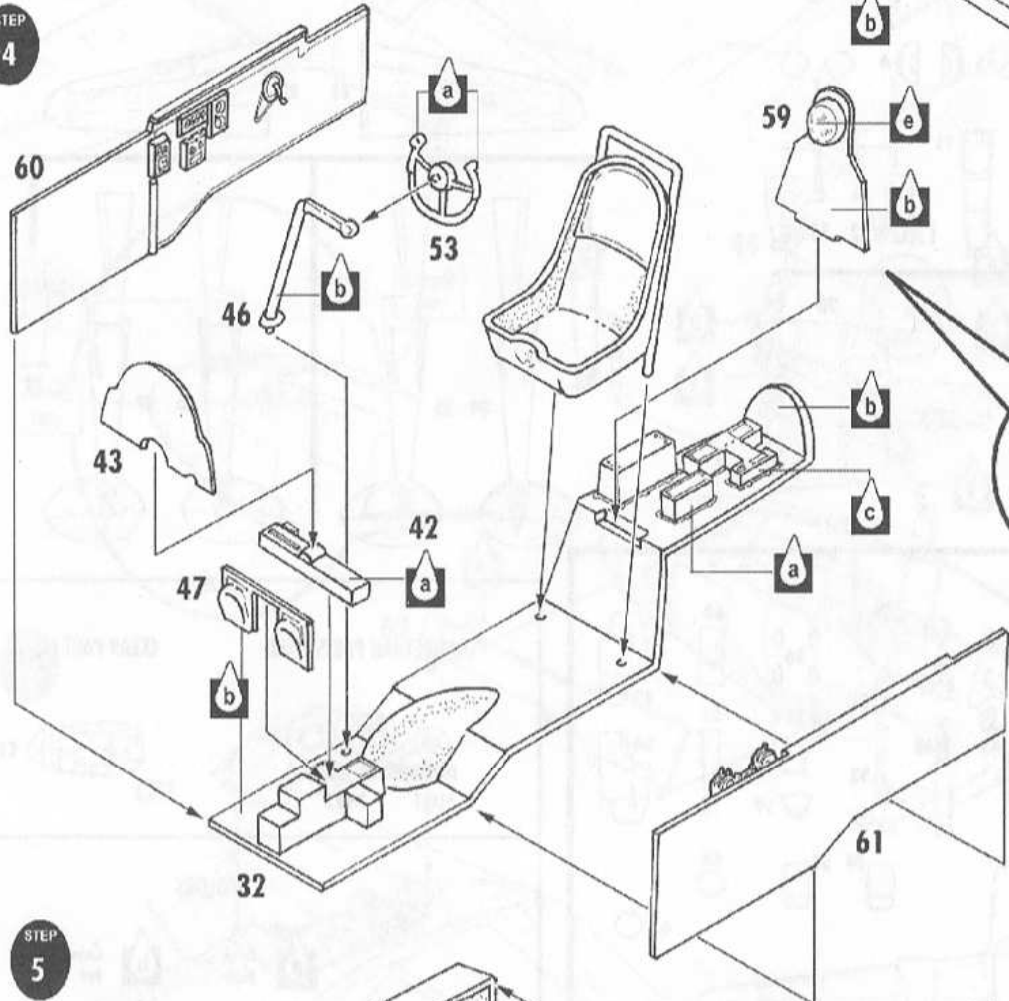

STEP 5

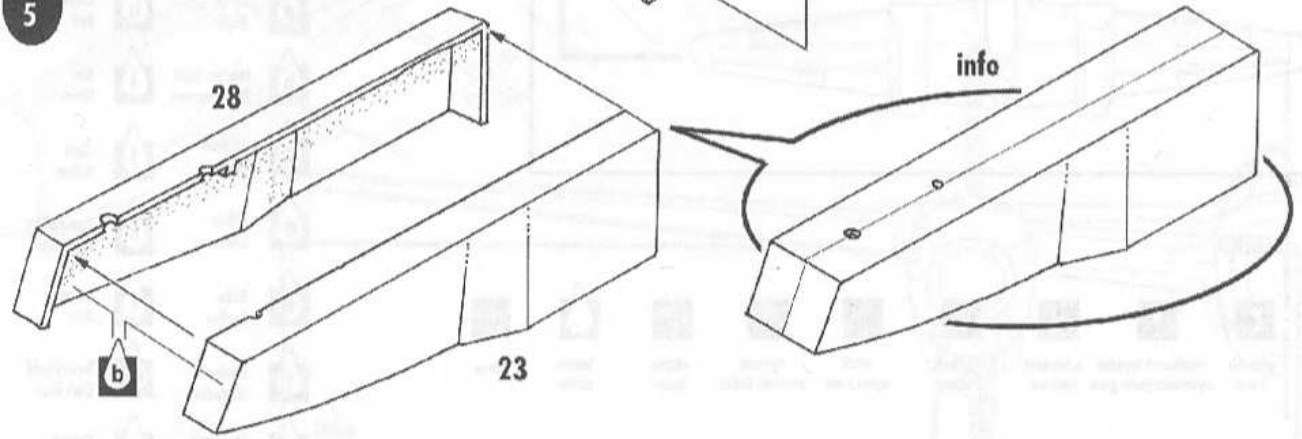

STEP

6

Zatmolit Putty

Zatmolit Putty

(WEIGHT)

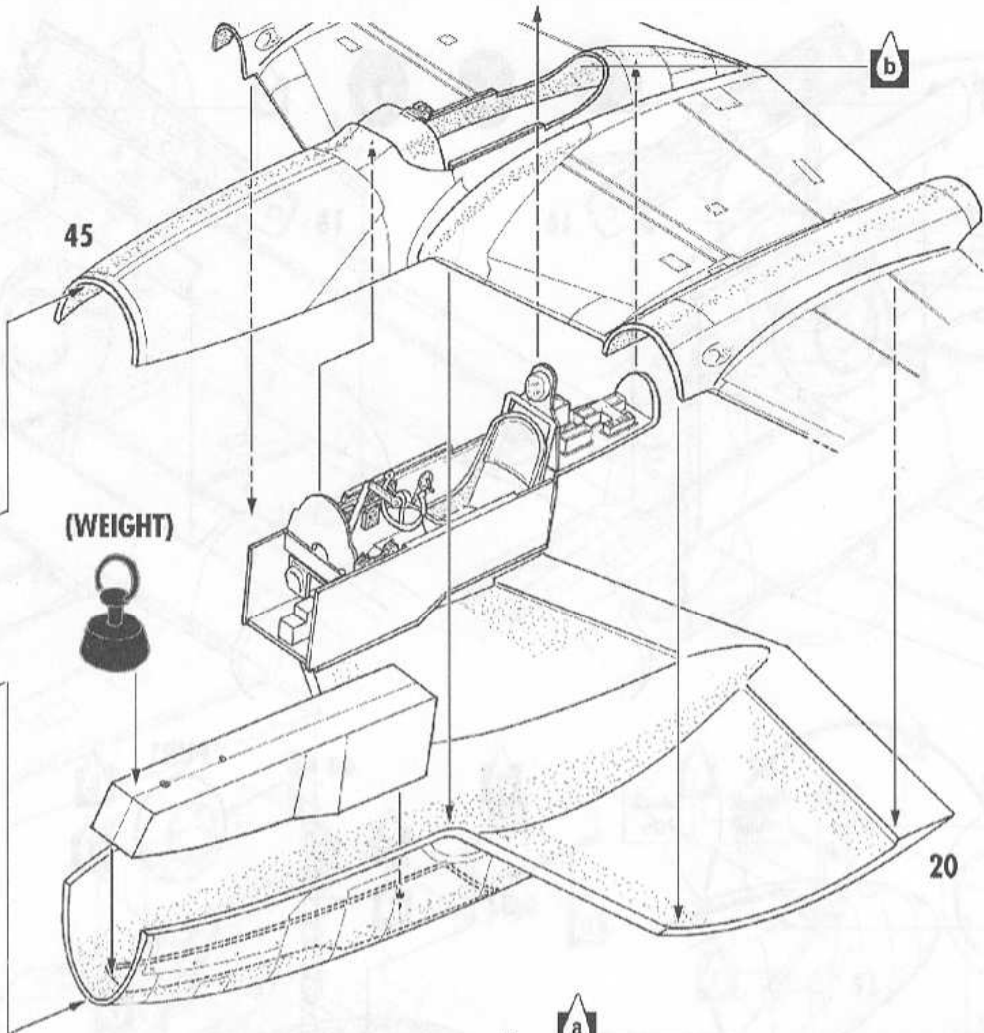

(LEFT TAIL STRUCTURE)

STEP

8

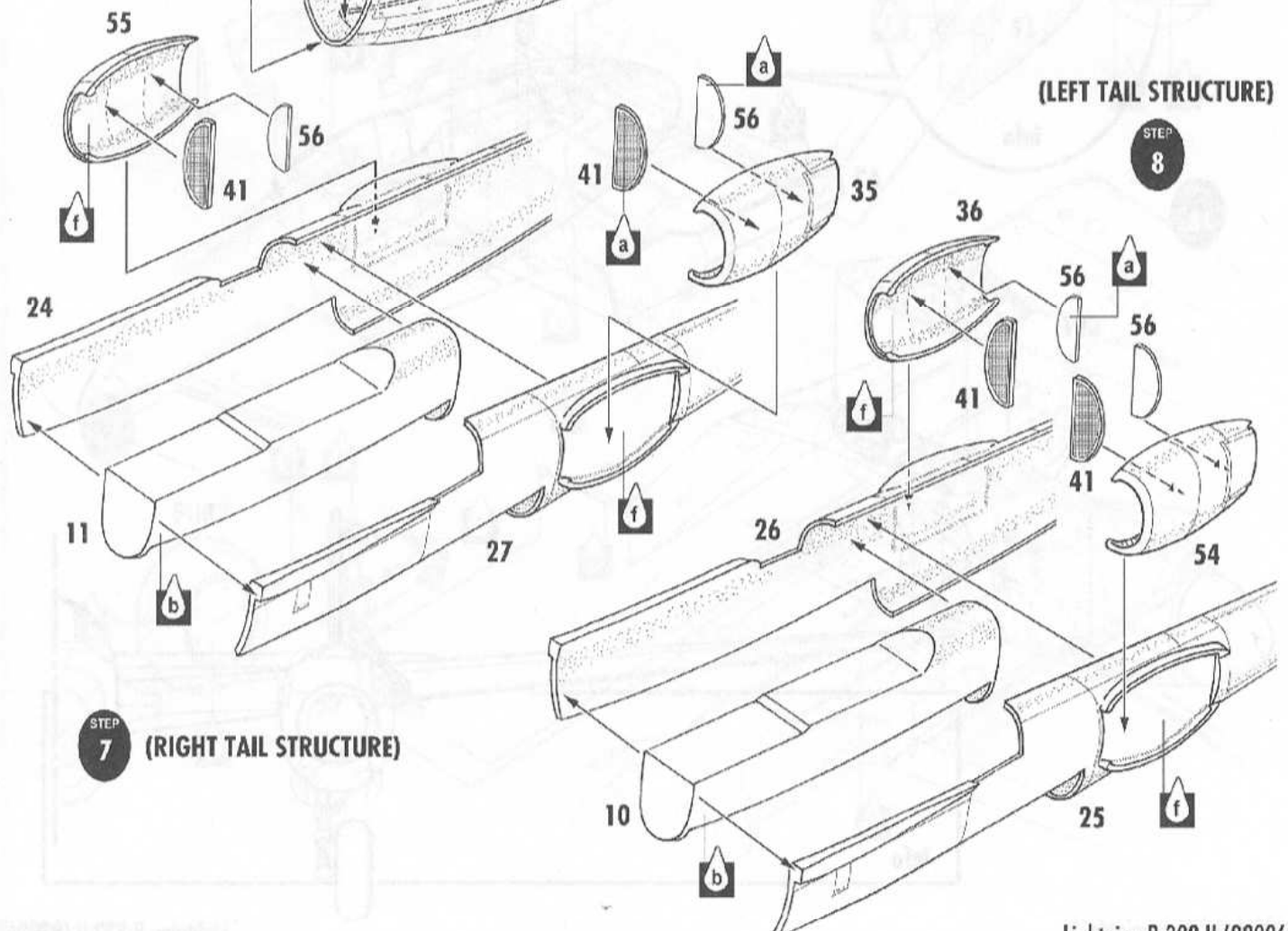

STEP

7

(RIGHT TAIL STRUCTURE)

STEP 9

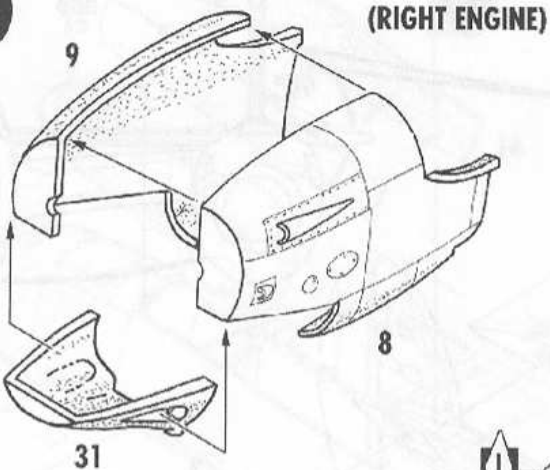

STEP 10

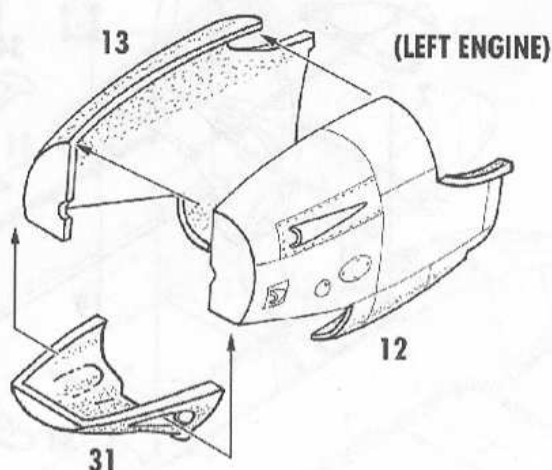

STEP 11

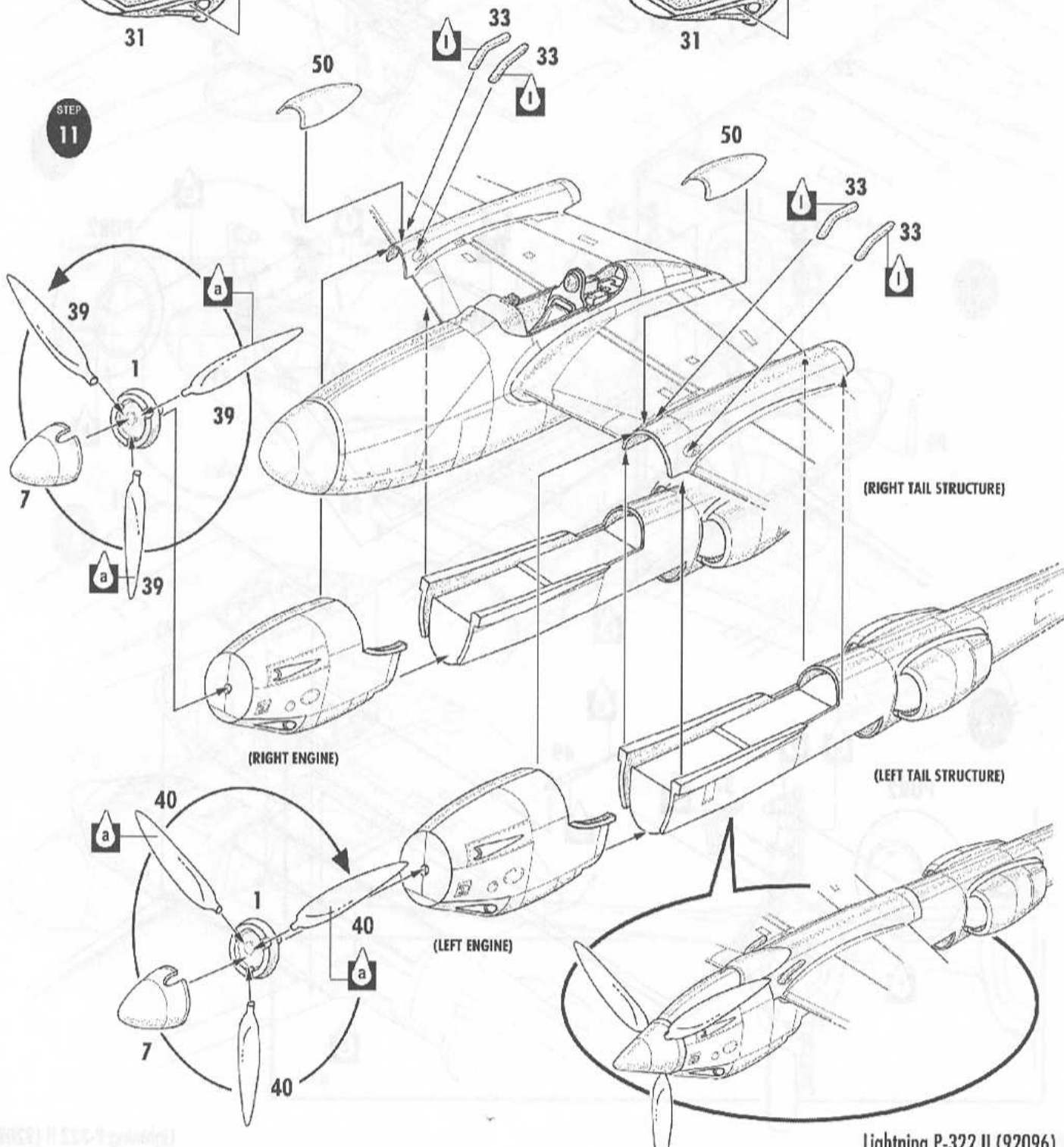



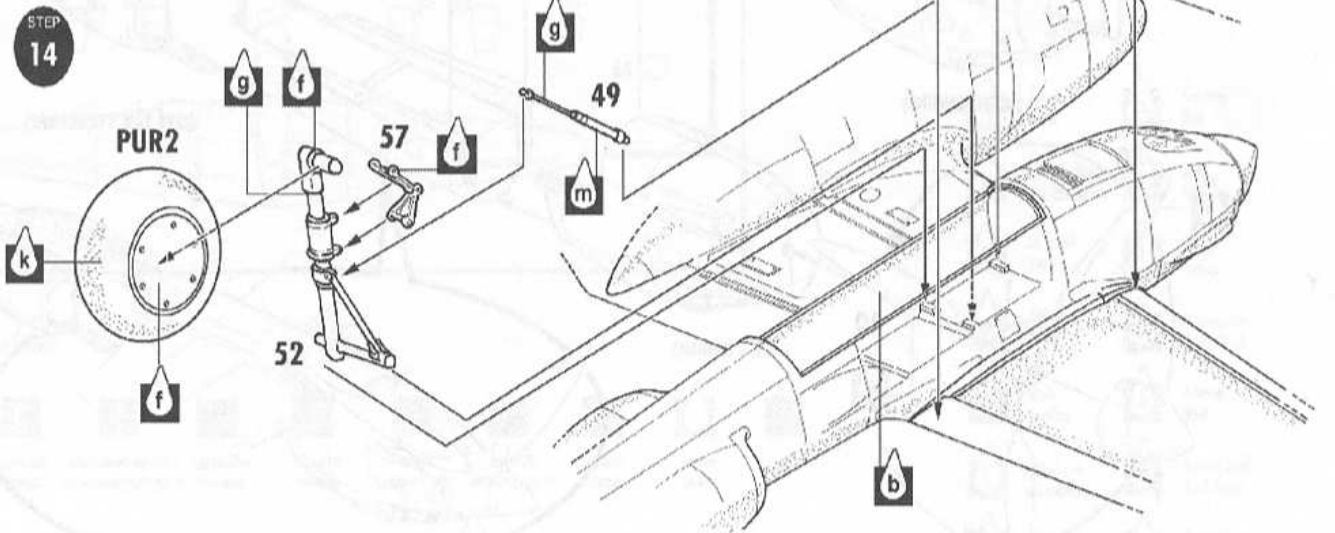
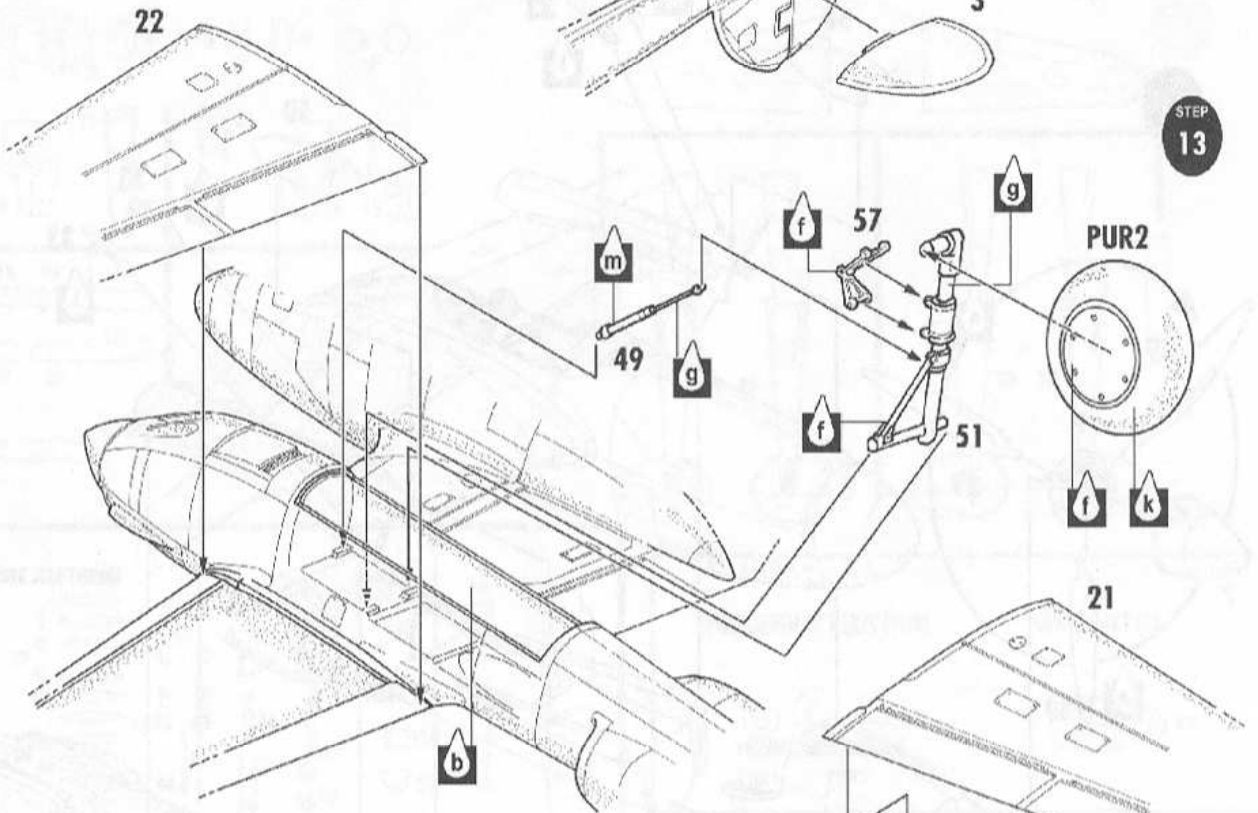
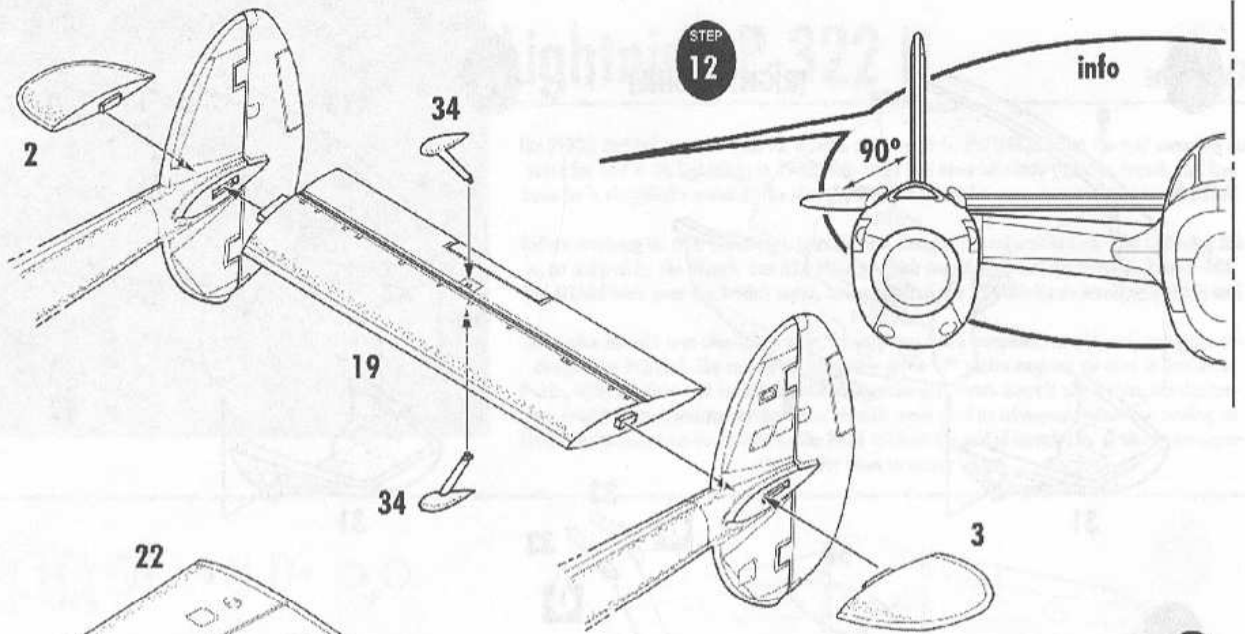

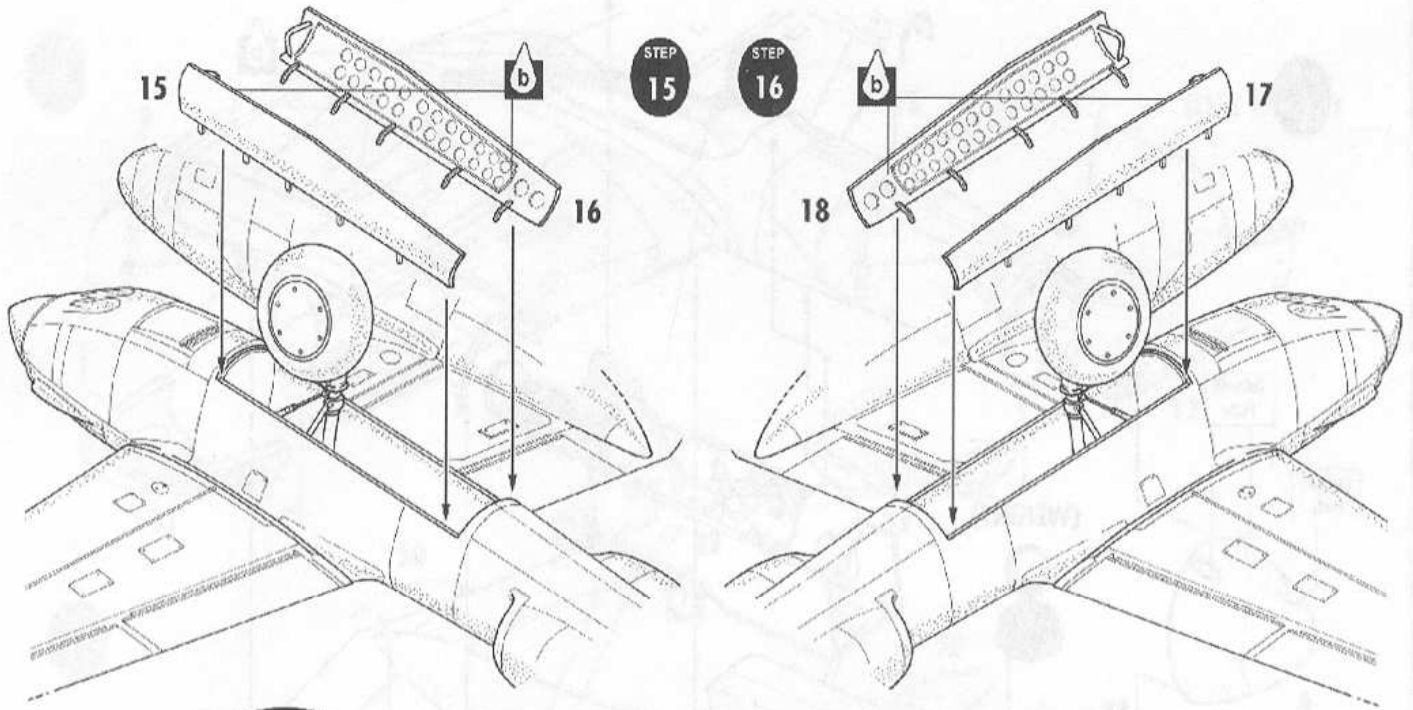

STEP 15

STEP 16

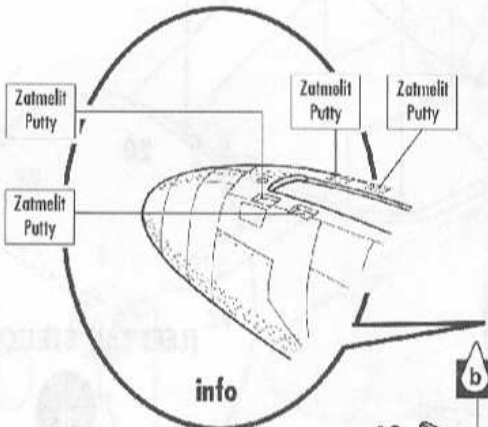
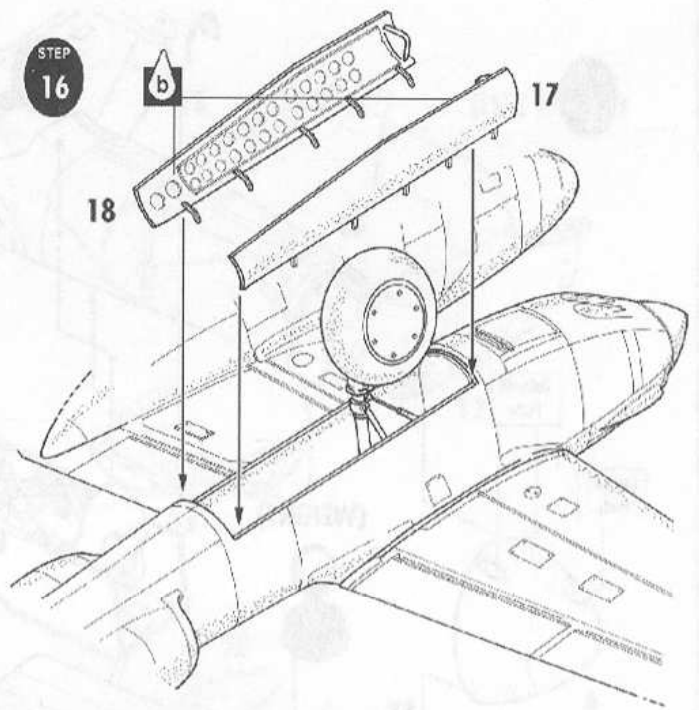

STEP 18

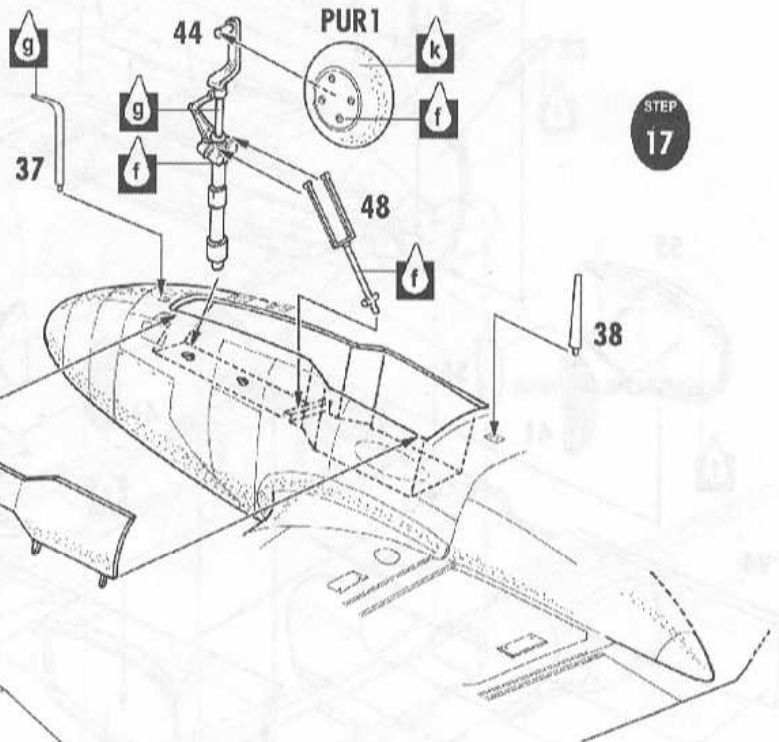

STEP 17

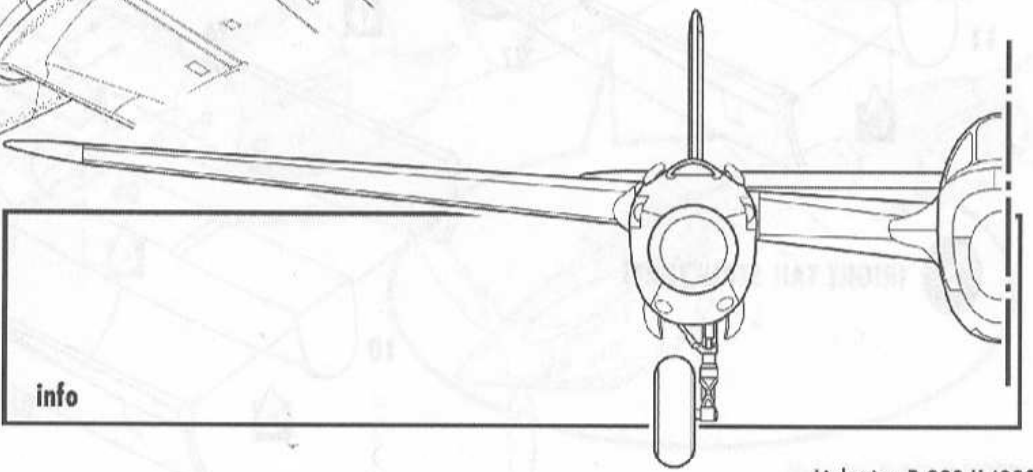
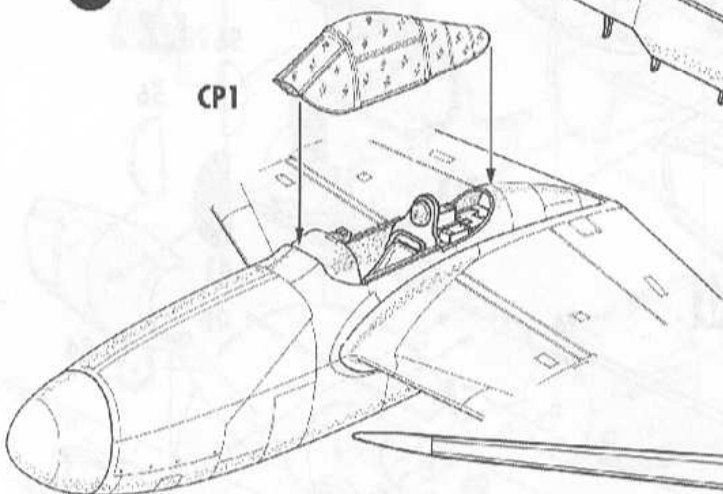

Lightning P-322 II (92096)



1 P-322-II, Lightning, AF 196, used as a trainer in California during late 1943

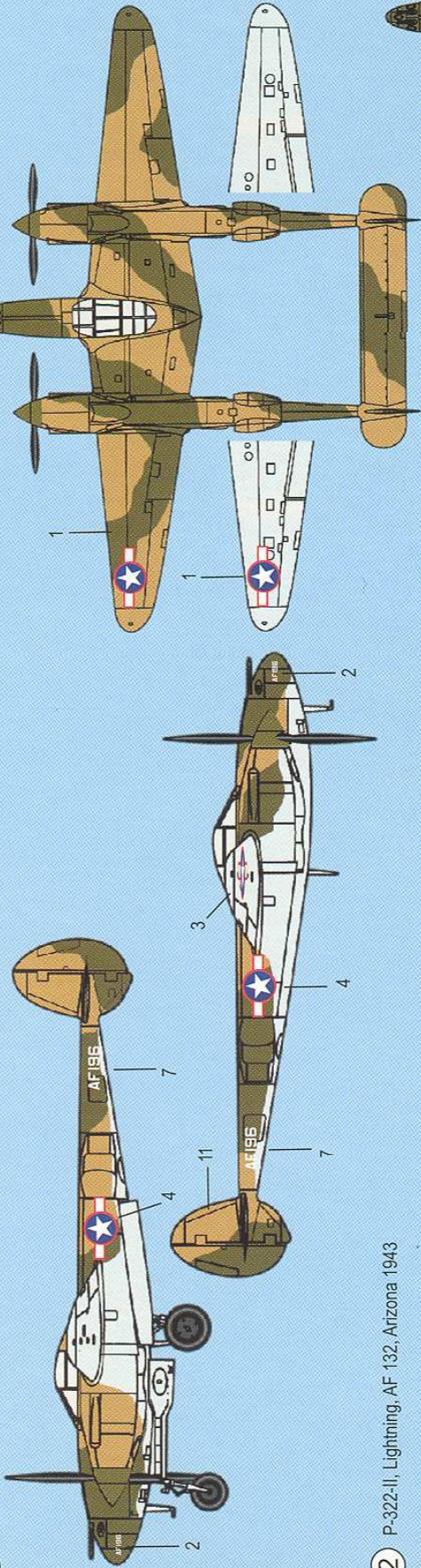

2 P-322-II, Lightning, AF 132, Arizona 1943

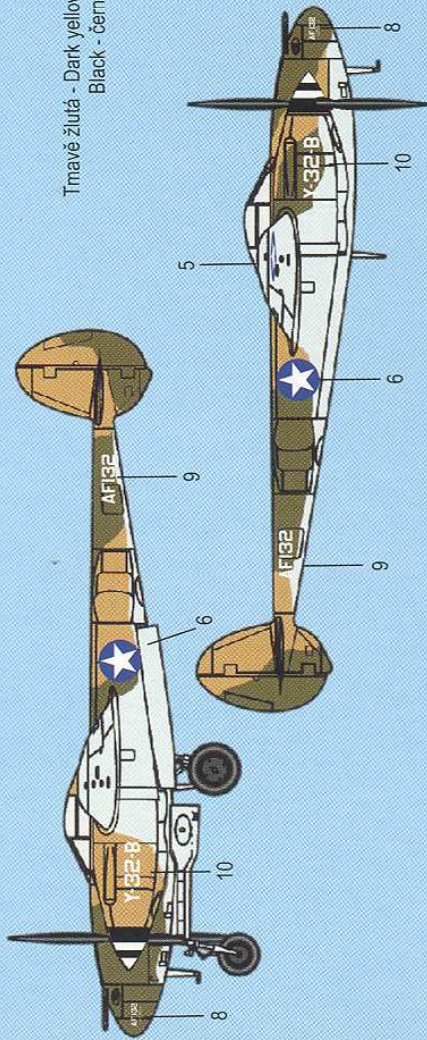

3 P-322-II Lightning, AF 116, Hamilton Field, 1942

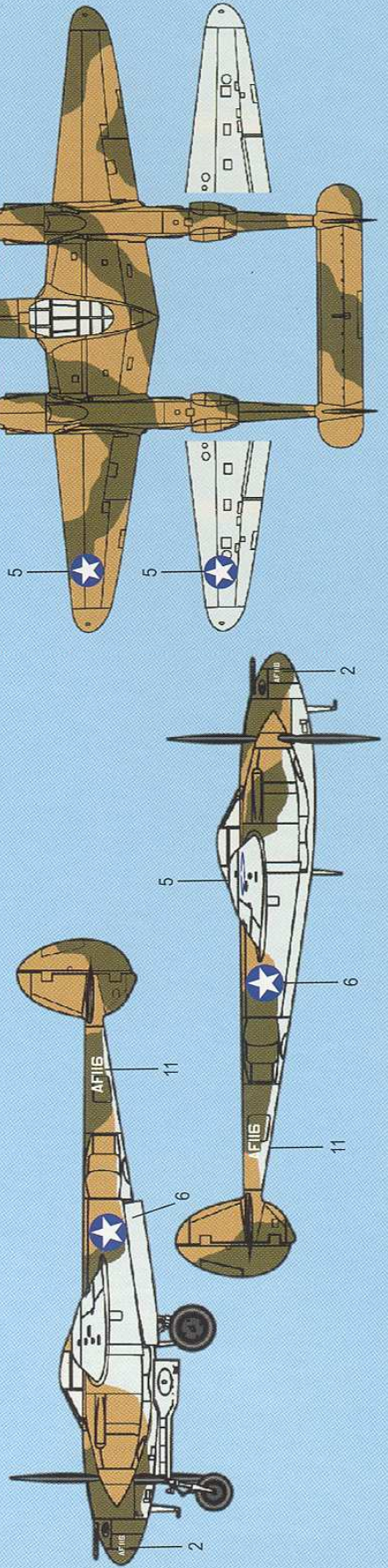

- Bílá - White
- Tmavě žlutá - Dark yellow
- Světle šedá - Sky type S
- Tmavě hnědá - Dark Earth
- Britská tmavě zelená - British Dark Green
- Černá - Black

Tmavě žlutá - Dark yellow  
Black - černá



# Lightning P-322 II

Americký stíhací letoun / American fighter from WW II

3 obtiskové verze  
3 decal version



The P-322 designation was used for aircraft taken over by the USAAF after the RAF cancelled an order for 667 Lightnings in 1942. This order had been inherited from the French, and had been for a simplified version of the aircraft, without the turbo superchargers used by all USAAF P-38s. Twenty two were completed as ordered, and given the designation P-322-I. The remaining 121 were given "F" series engines, although they still lacked the turbo-supercharger. These aircraft were given the designation P-322-II. In American service these aircraft were used as advanced trainers, providing an ideal way to introduce new pilots to the P-38 without the added complexity of the turbo-supercharger for them to worry about.

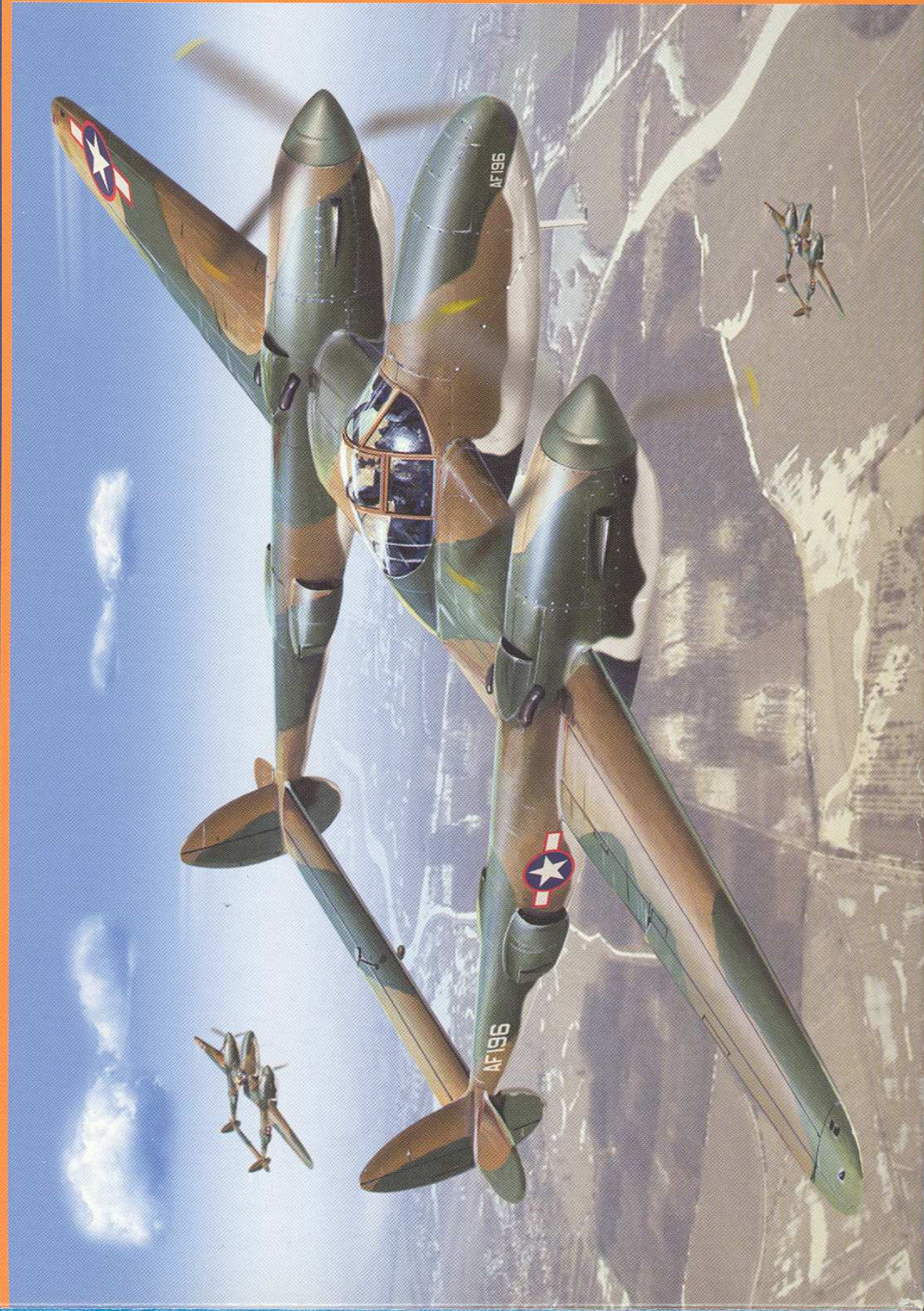

**RS**  
MODELS

**1:72 SCALE  
PLASTIC KIT**

**92096**