

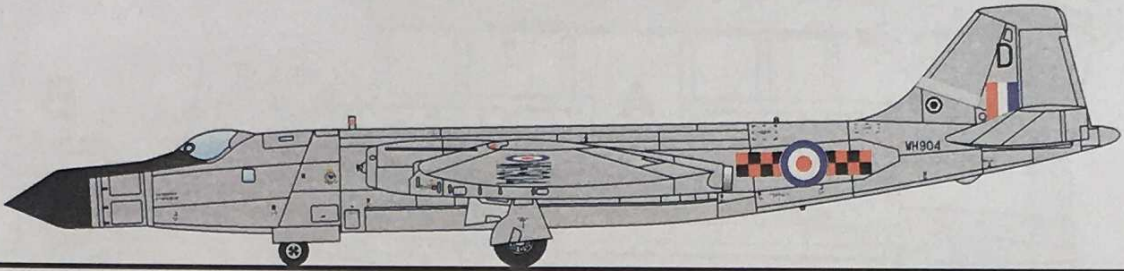

1/72 SCALE MODEL CONSTRUCTION KIT English Electric Canberra T.11/TP.52

72004



English Electric Canberra T.11 була створена в 1958 році як тренаж повітряно-десантних перехоплень для екіпажів Gloster Javelin. З цією метою були вилучені з резерву літаки модифікації B.2 і оснащені під гострим конічним носом станції радіолокації Ferranti AIRPASS AI/17. Окрім того, що літаки служили для тренування екіпажів радарів перехоплення, T.11 був і загальним учбовим літаком для всього екіпажу, і часто на борту було чотири члени екіпажу: учень і інструктор-навігатор, сиділи в задній частині кабіни, а пілота-курсанта і інструктора - у передній, причому останній - на розкладному стільці біля місця пілота. З середини 1960-х років ця роль Канберри стала не потрібна, і більшість з T.11 змінили свої радари на носовий баласт, перетворившись на прості учбові машини для пілотування.

Всього у стандарт T.11 перероблено дев'ять B.2.

Шведські військово-повітряні сили придбали дві Канберри у RAF в 1960 році, і вони були змінені до стандарту T.11 фірмою Boulton Paul. Літаки були потім модифіковані в Швеції як шпигунські літаки для перехоплення радянських, польських та східногерманських військових радіопередач, хоча це було не публічно. Канберри отримали позначення TP.52 і находились в експлуатації у якості "випробувального літака", поки не були замінені двома T3.85 Caravelle в 1971 році.

The English Electric Canberra T.11 was introduced in 1958 as a radar airborne intercept trainer for Gloster Javelin crews. Redundant B.2s were taken out of storage for this purpose, and fitted with a sharply-pointed conical nose housing the Ferranti AIRPASS AI/17 radar. In addition to serving as a radar intercept trainer, the T.11 served the role as general crew trainer and it was not uncommon for it to carry four crew; a pupil and instructor navigator seated in the rear, and a pilot and pupil pilot seated in front, the latter on the fold-down rumble seat adjacent to the pilot. By the mid 1960s, this role was no longer needed and many T.11s had their radars removed and replaced with nose ballast, thus becoming the Canberra T.19 general crew trainer.

Nine B.2s converted to trainers for pilots and navigators of all-weather interceptors to operate the Airborne Intercept radar, crew of four.

The Swedish Air Force purchased two Canberras from the RAF in 1960 and had these modified to T11s by Boulton Paul. The aircraft were secretly modified in Sweden as espionage aircraft for eavesdropping on primarily Soviet, Polish and East German military radio transmissions, although this was not publicly admitted until 10 years later. The Canberras were given the designation TP 52, and taken into service as "testing aircraft", until they were replaced by two TP 85 Caravelles in 1971

Технічні характеристики / Technical specifications:

Довжина/Length - 20,56 м; Розмах/Wingspan - 19,50 м; Висота/Height - 4,77 м; Злітна маса/Loaded weight - 24915 kg
Дальність польоту/Range - 5440 км; Крейсерська швидкість/Cruising speed - 830 км/ч;
Макс. висота польоту/Ceiling - 14630 м; Екіпаж/Equipage - 3.

СПЕЦІАЛЬНІ СИМВОЛИ/USED SYMBOLS



CEMENT
КЛЕЯТИ



DON'T CEMENT
НЕ КЛЕЯТИ



REMOVE
ВІДРІЗАТИ



SYMMETRICAL
СИМЕТРИЧНО



MULTIPLE
КРАТНО



BEND
ЗІГНУТИ



OPEN WHOLE
СВЕРДЛИТИ



VARIANTS
ВАРІАНТИ



TO PAINT
ФАРБУВАТИ

КОЛЬОРИ ФАРБ/USED PAINTS



White
Humbrol 34



Black
Humbrol 85



Matt Black
Humbrol 33



Steel
Humbrol 27003



Aluminum
Humbrol 56



Light Grey
Humbrol 64



Red
Humbrol 153



Yellow
Humbrol 24



Brown
Humbrol 186



Pale Yellow
Humbrol 81

PARTS OF THE MODEL

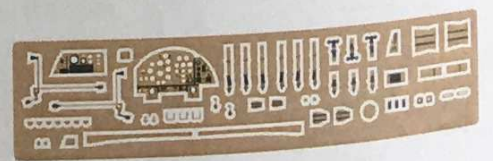
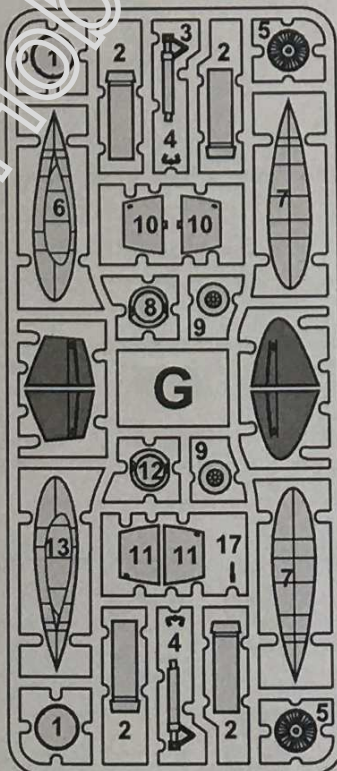
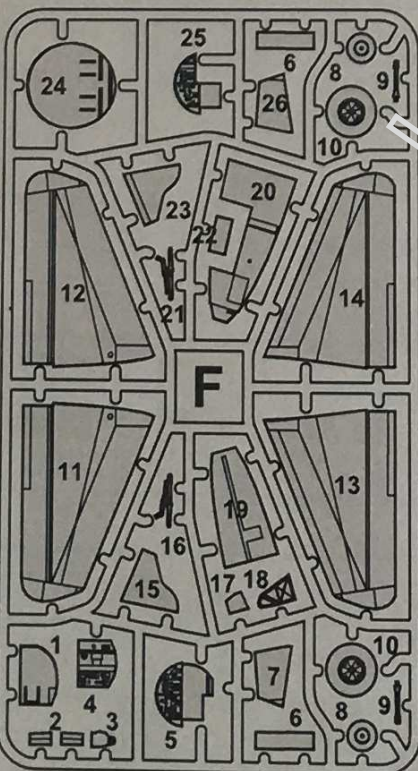
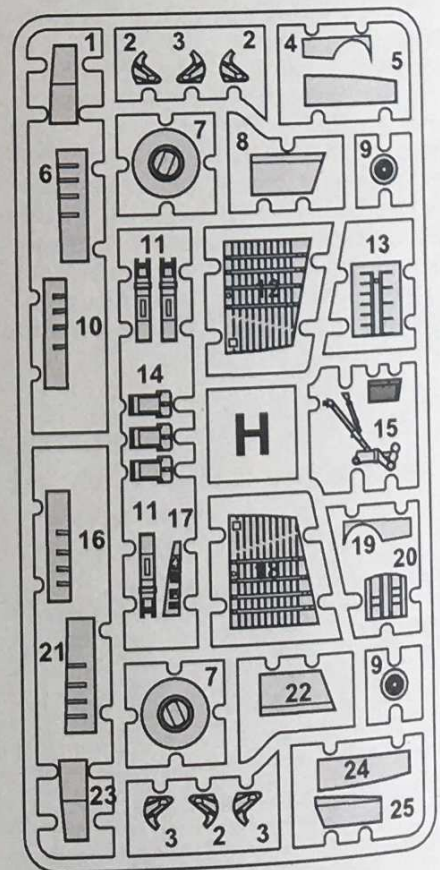
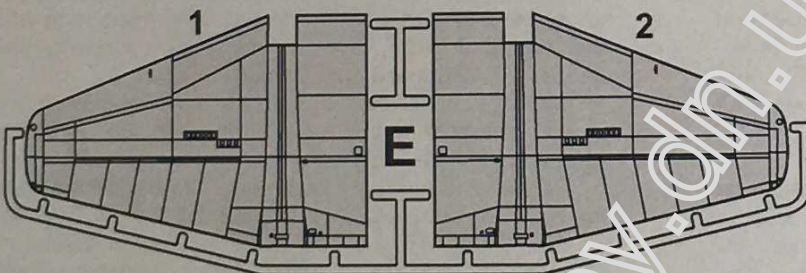
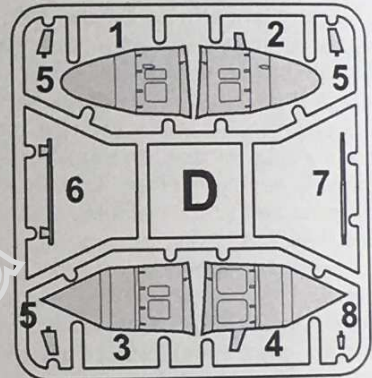
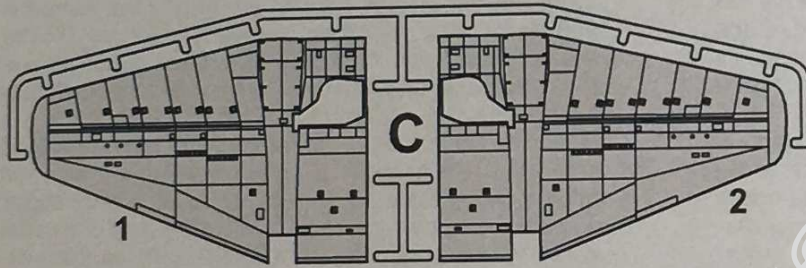
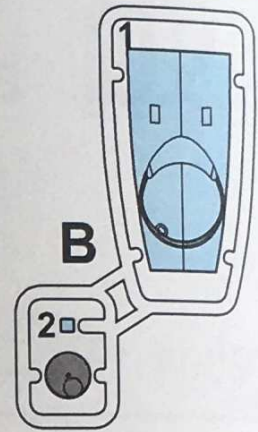
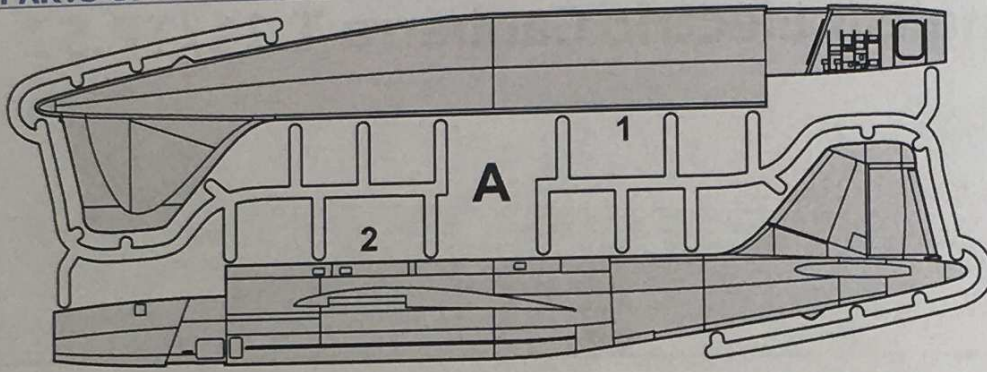

PARTS OF THE MODEL

Addition to page 2

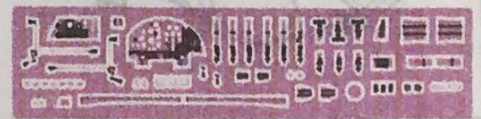
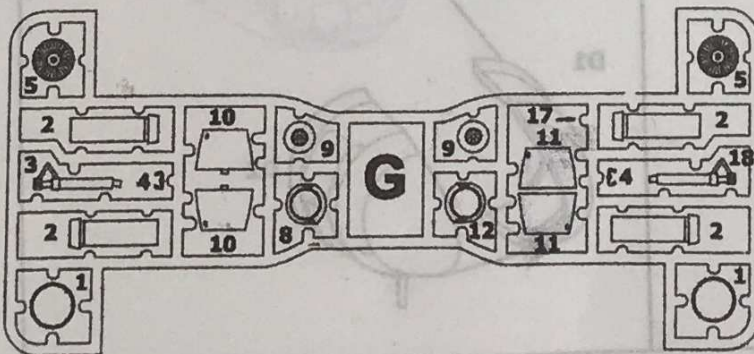
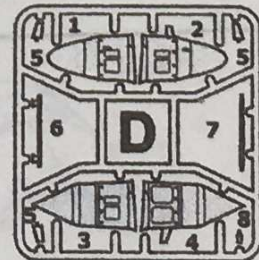
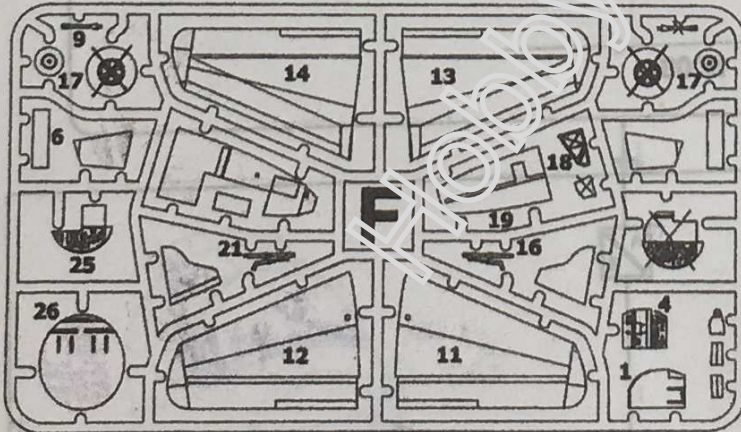
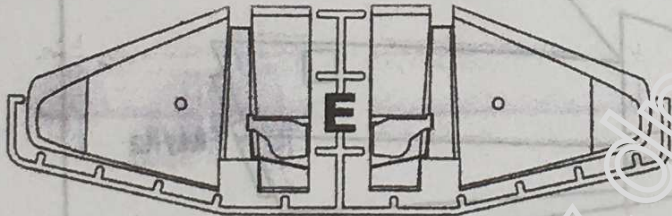
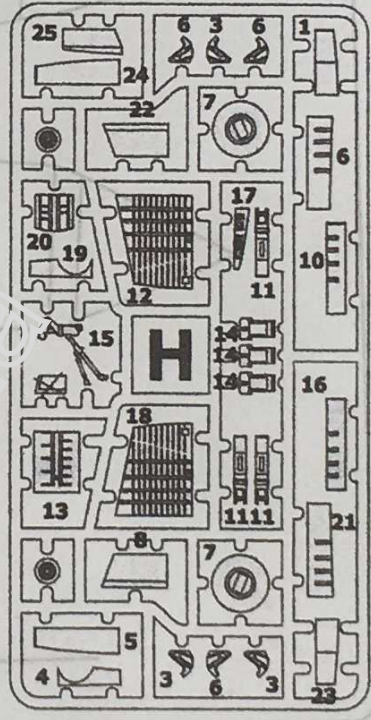
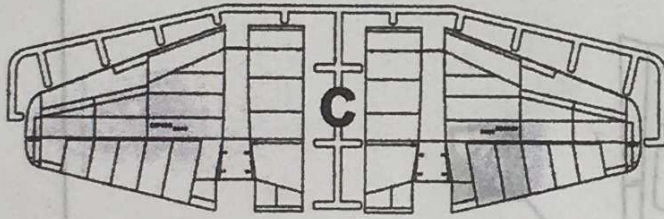
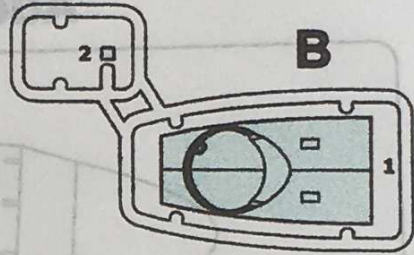
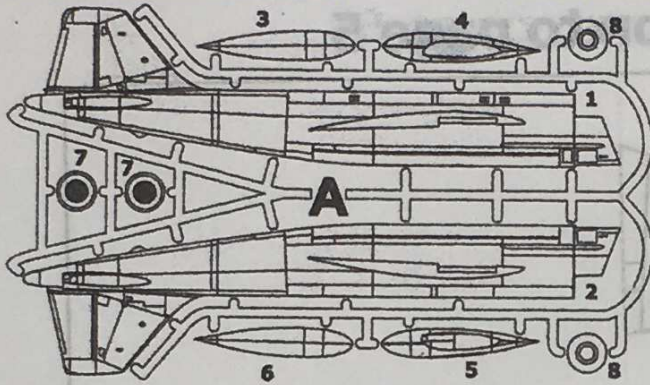

1 F25; Pe6; film

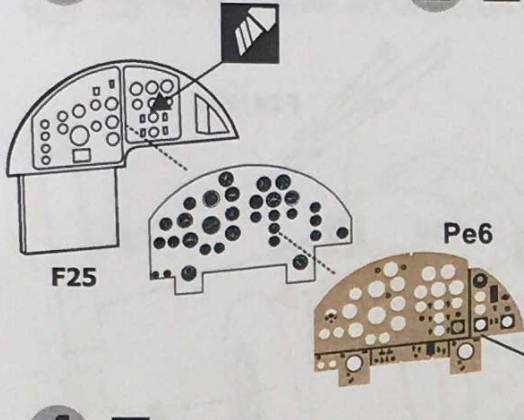

2 F4,F6; Pe3; film

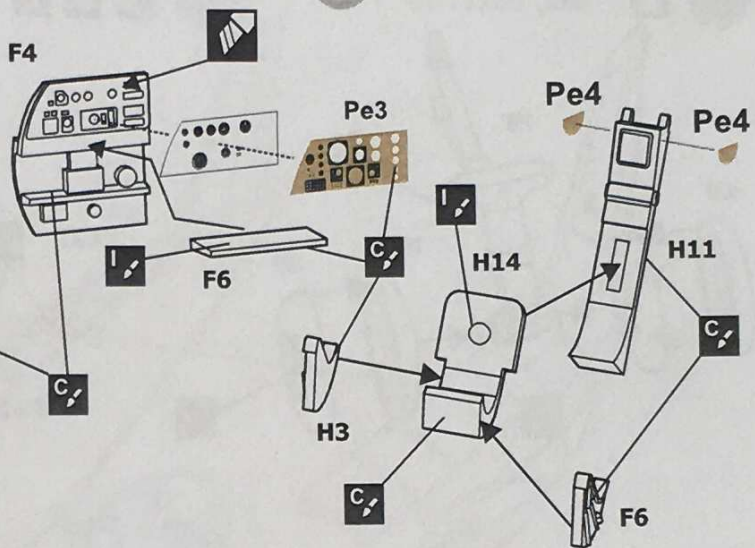

4 F26;H8,H13,H20,H22

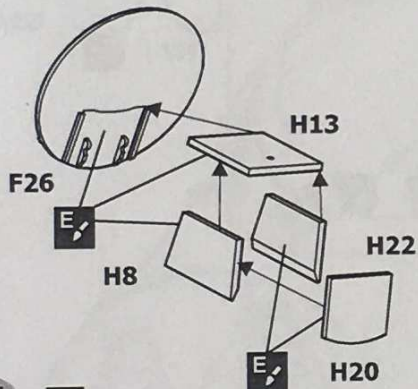

6 F20;Pe7x2,Pe8x2,Pe9x2,Pe13x2,Pe23x2

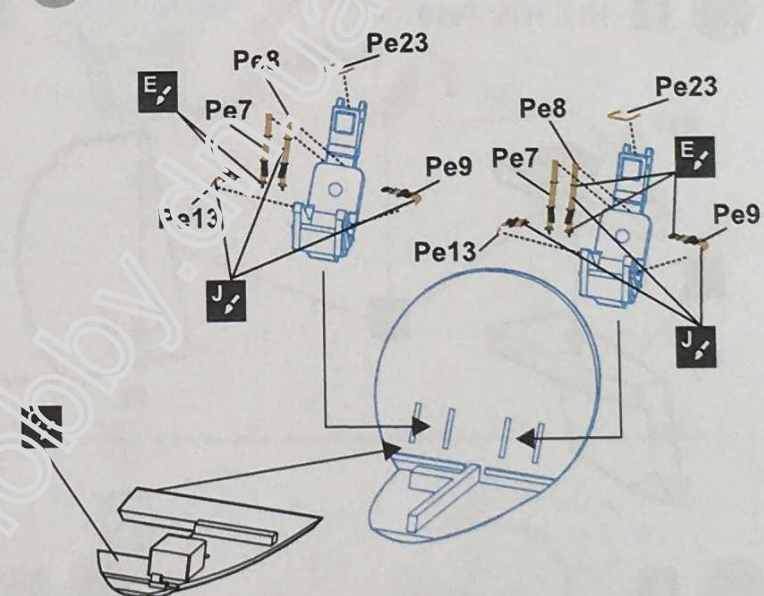

5 F19

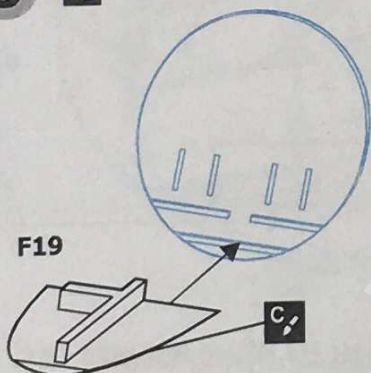

7 F9; G4; Pe22

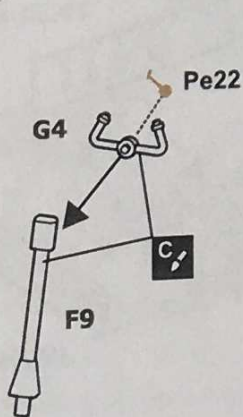

8 F18; Pe14,Pe15

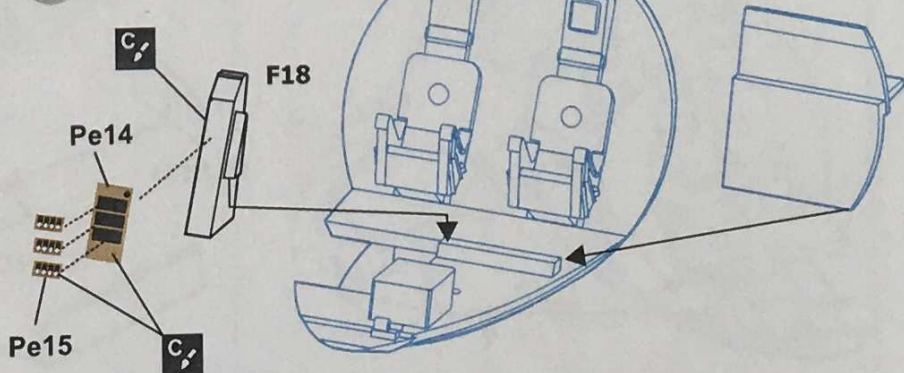

9 F8x2; G9x2,H15

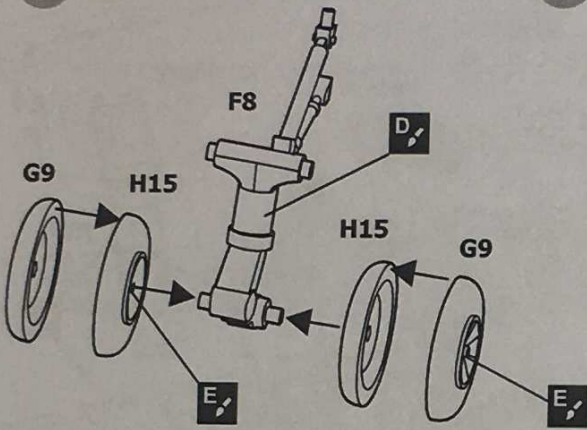

10 F10x2,F16,F21; G3,G18; H7; Pe20,Pe27

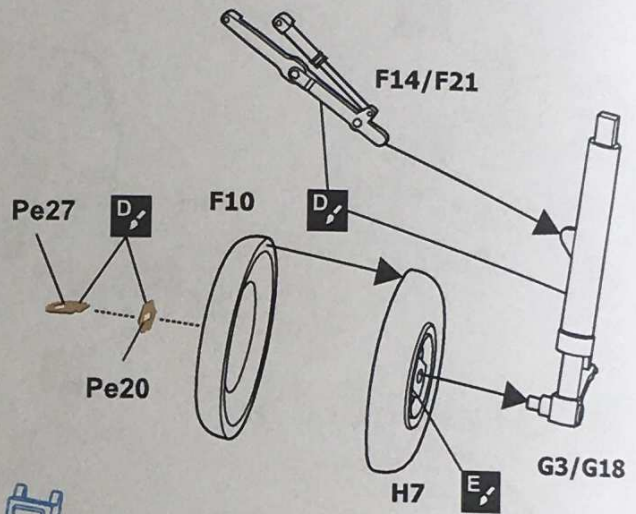

11 H17, H25; Pe10

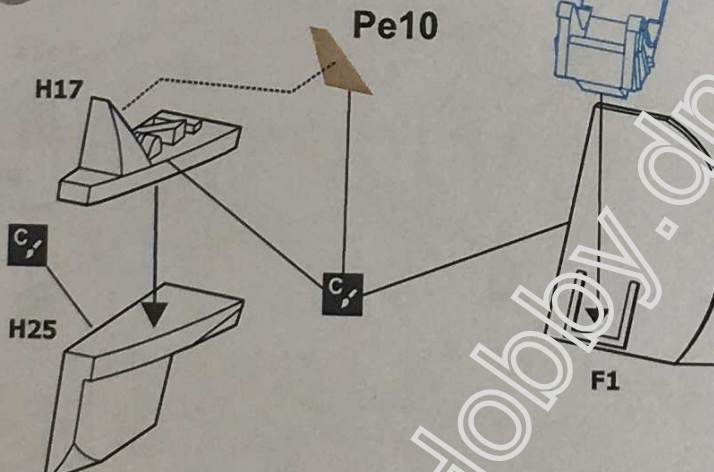

12 F1

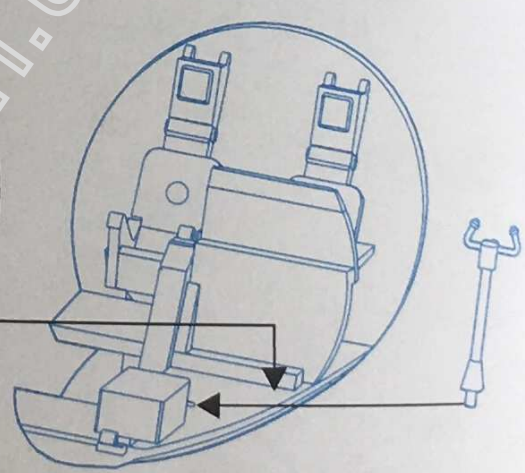

13

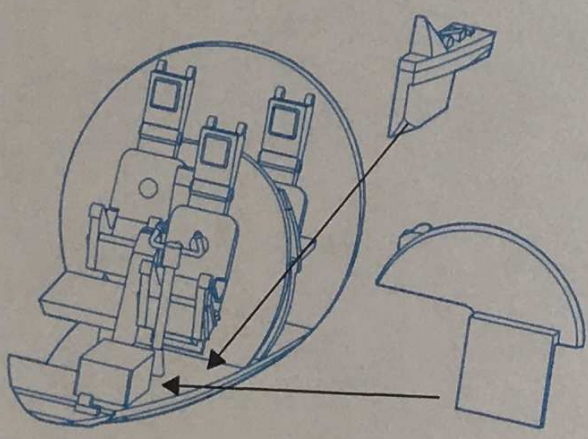

14 H1,H4,H5,H6,H10,H12,H16, H18,H19,H21,H23,H24

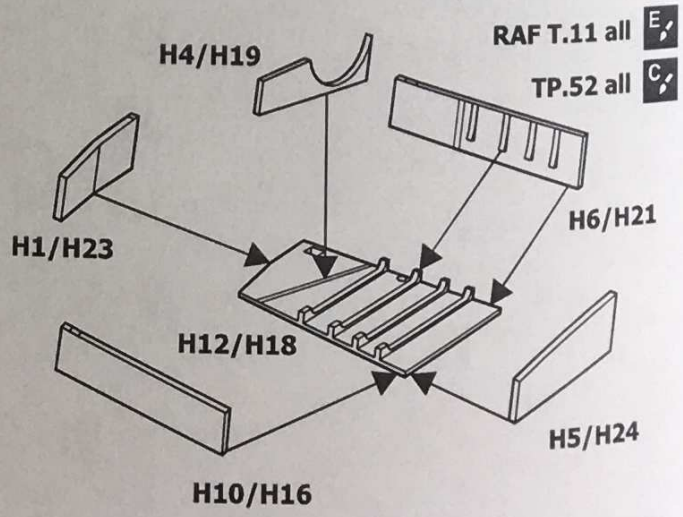

RAFT.11 all
TP.52 all

15  A1,A2; B1,B2; D1,D2,D3,D4

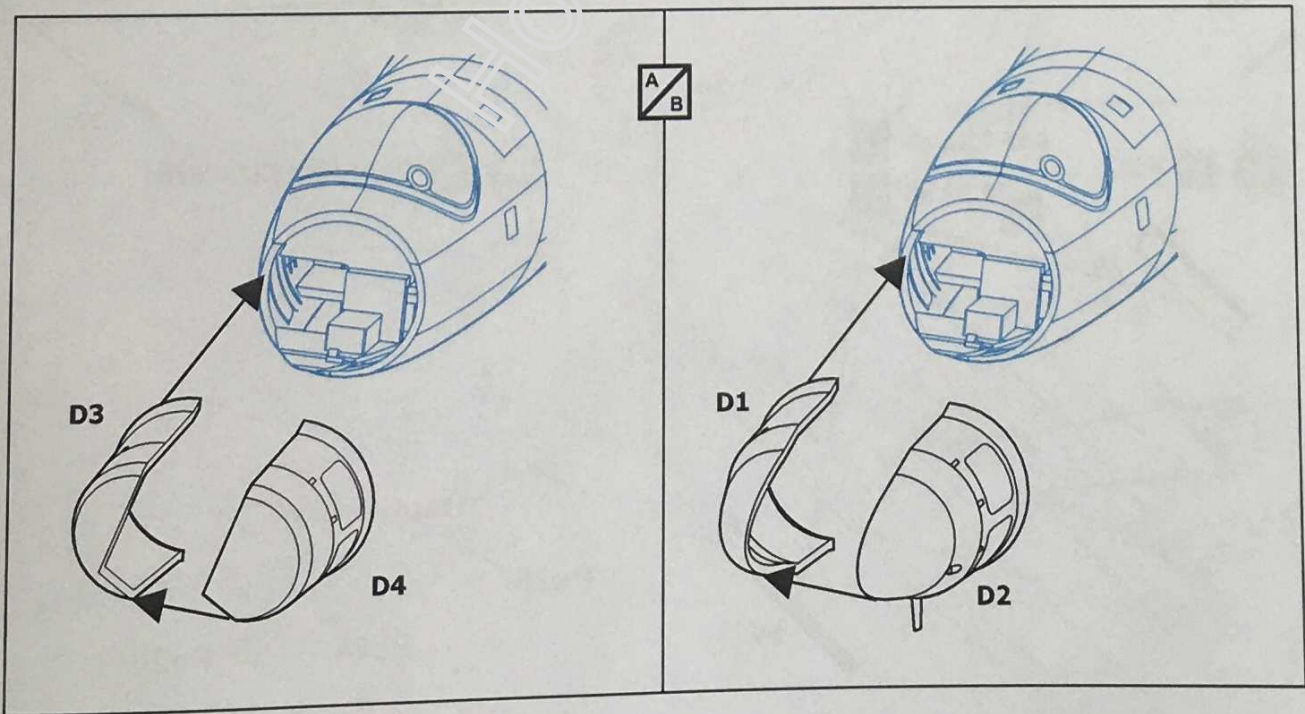
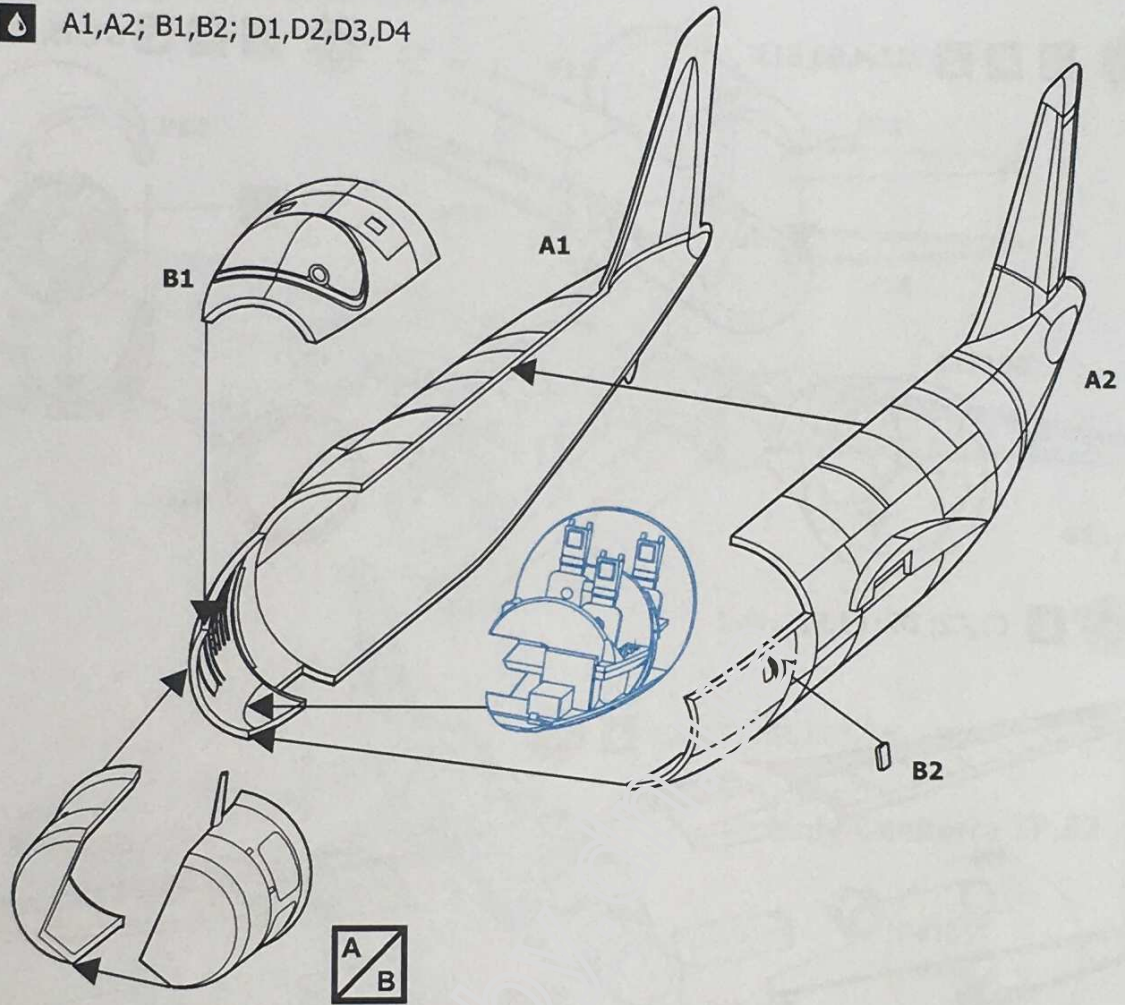

5 pages of normal

Addition to page 5

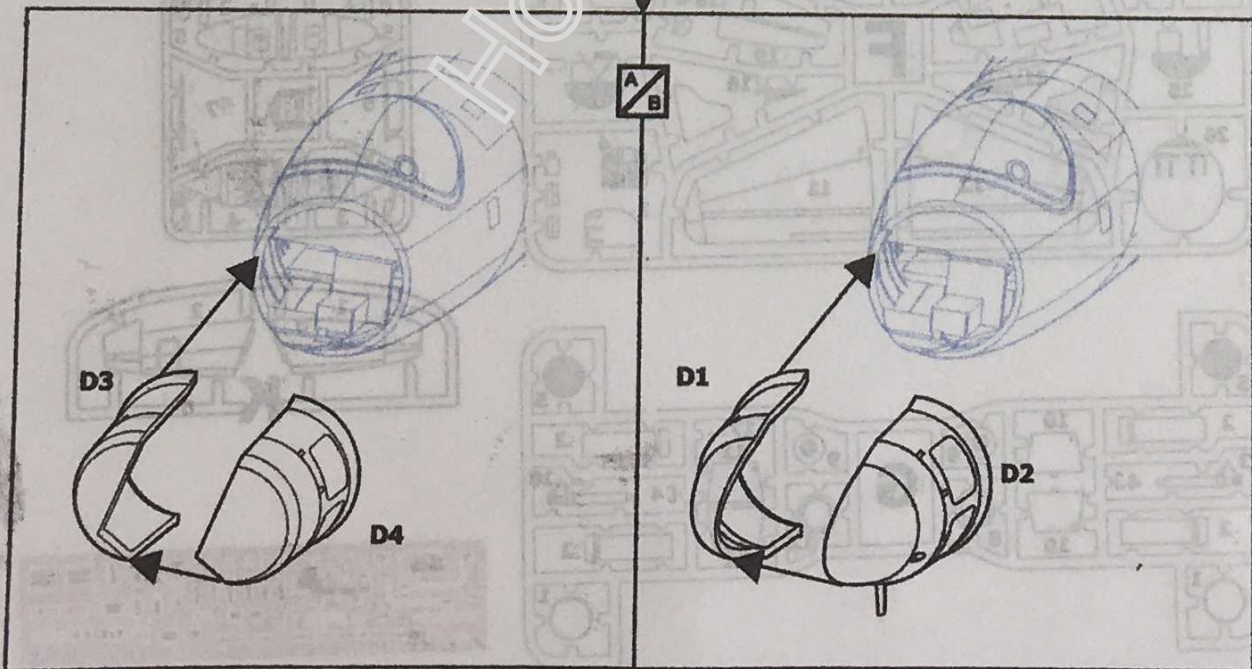
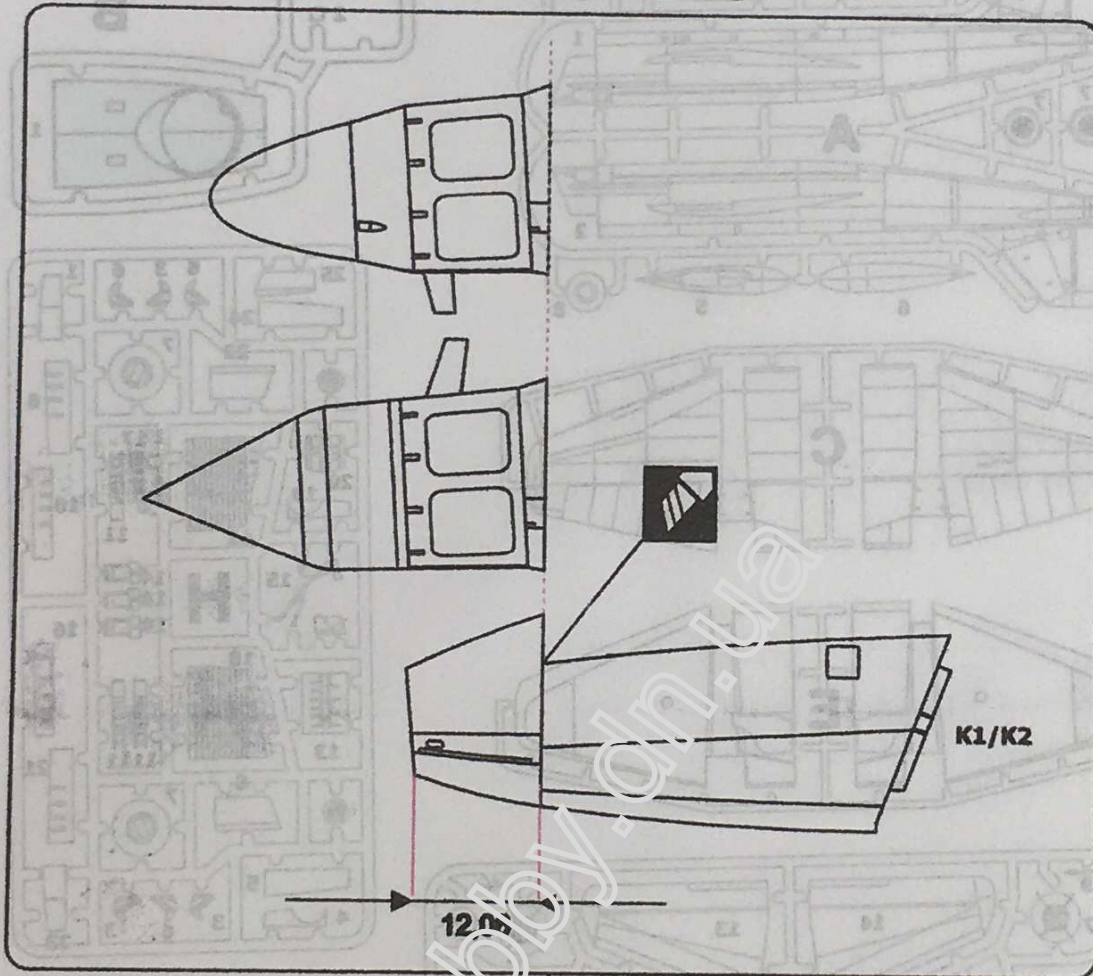

16 x2 AA G2x4,G8,G12

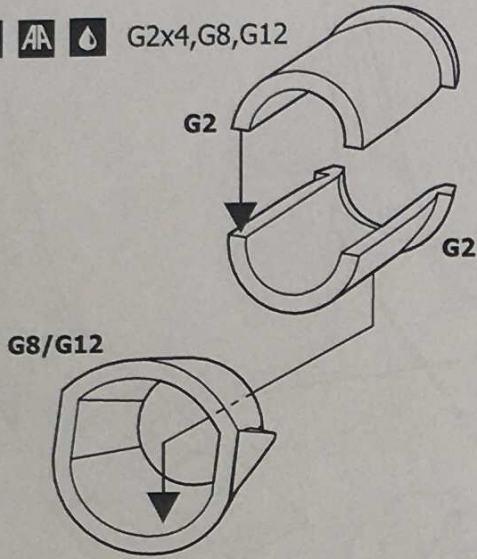

17 x2 AA G1,G5,G10,G11

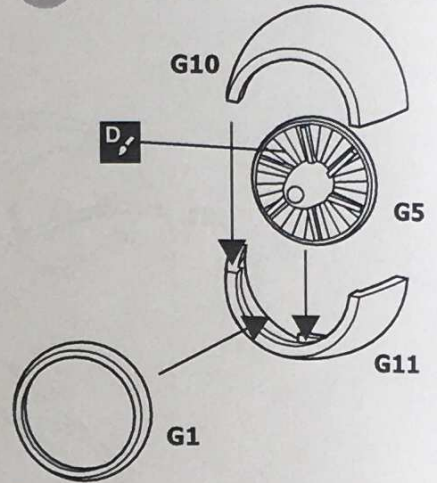

18 C1,C2; D7; E1,E2; H9x2

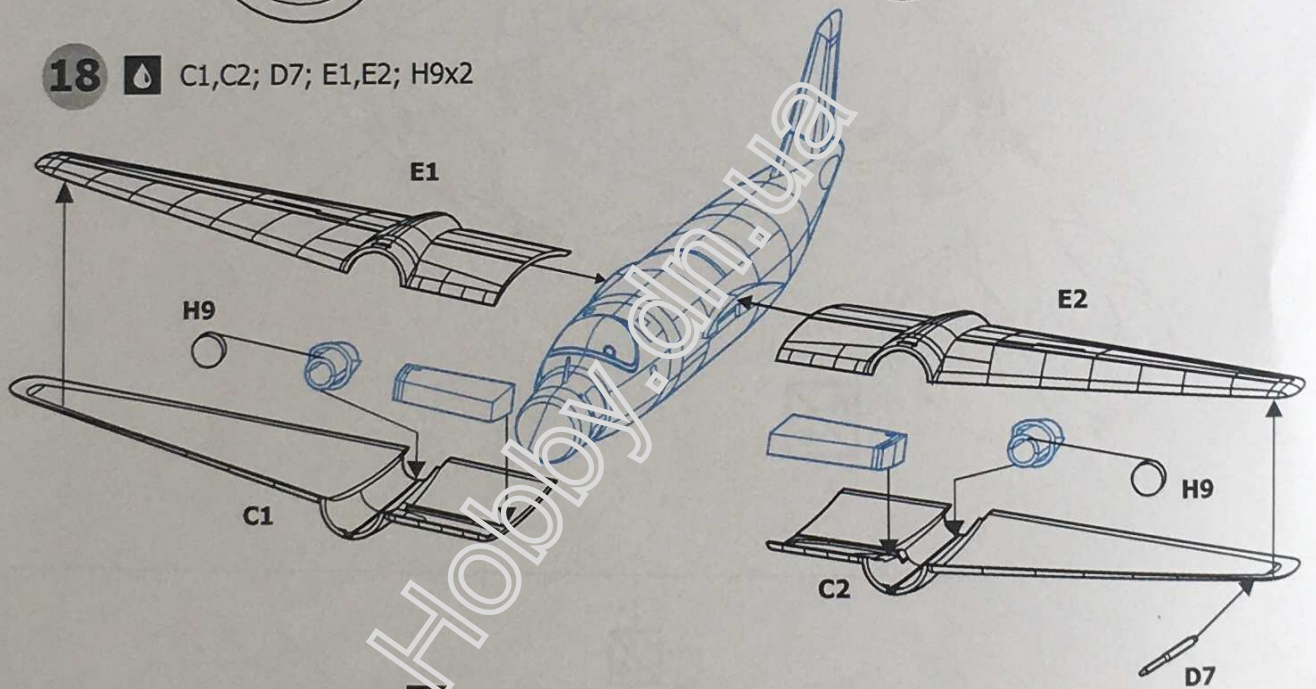

19 F6x2 RAF T.11 all E TP.52 all C

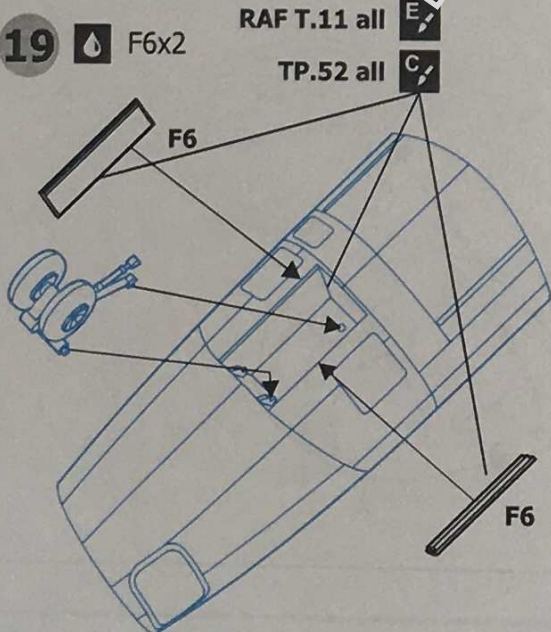

20 Pe24,Pe26/27, Pe28

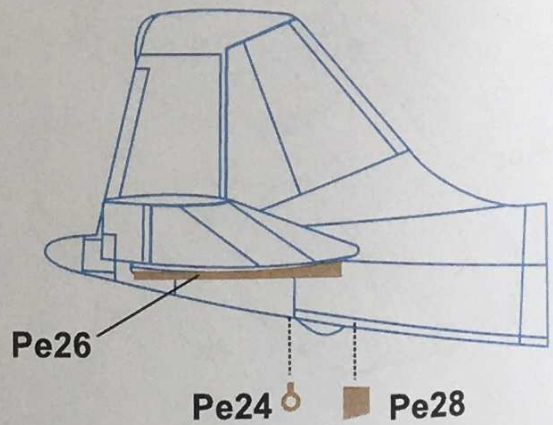

21  F11,F12,F13,F14; G6,G7x2,G13

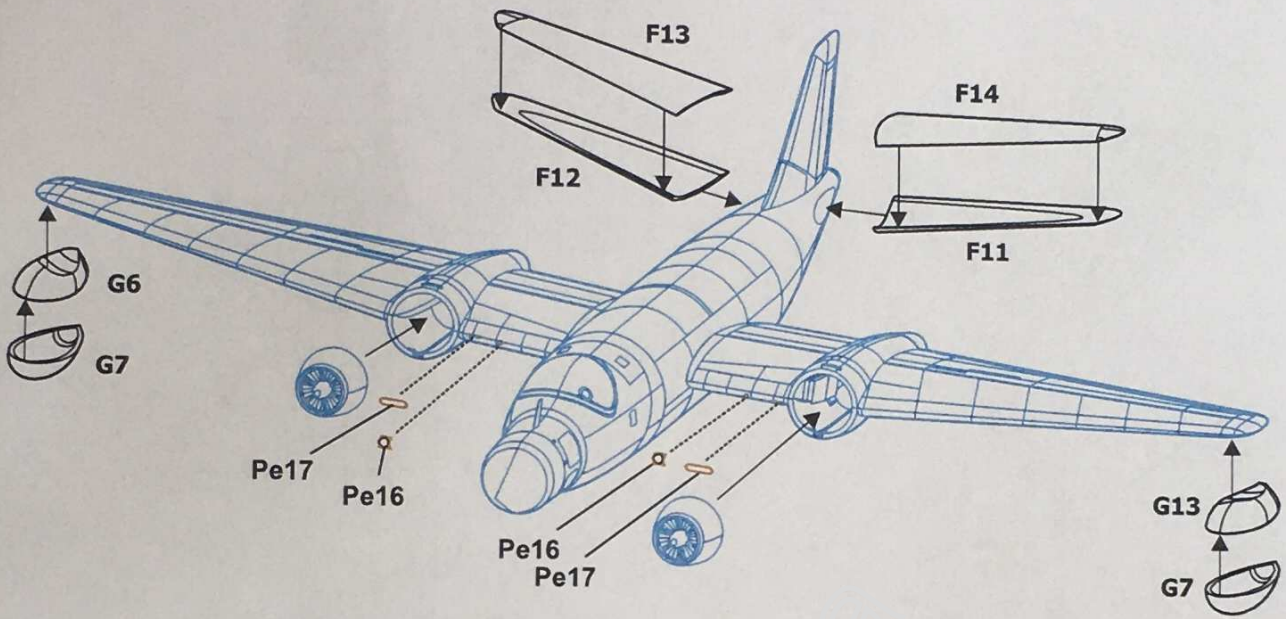

22  F2x2,F7,F15,F23,F26

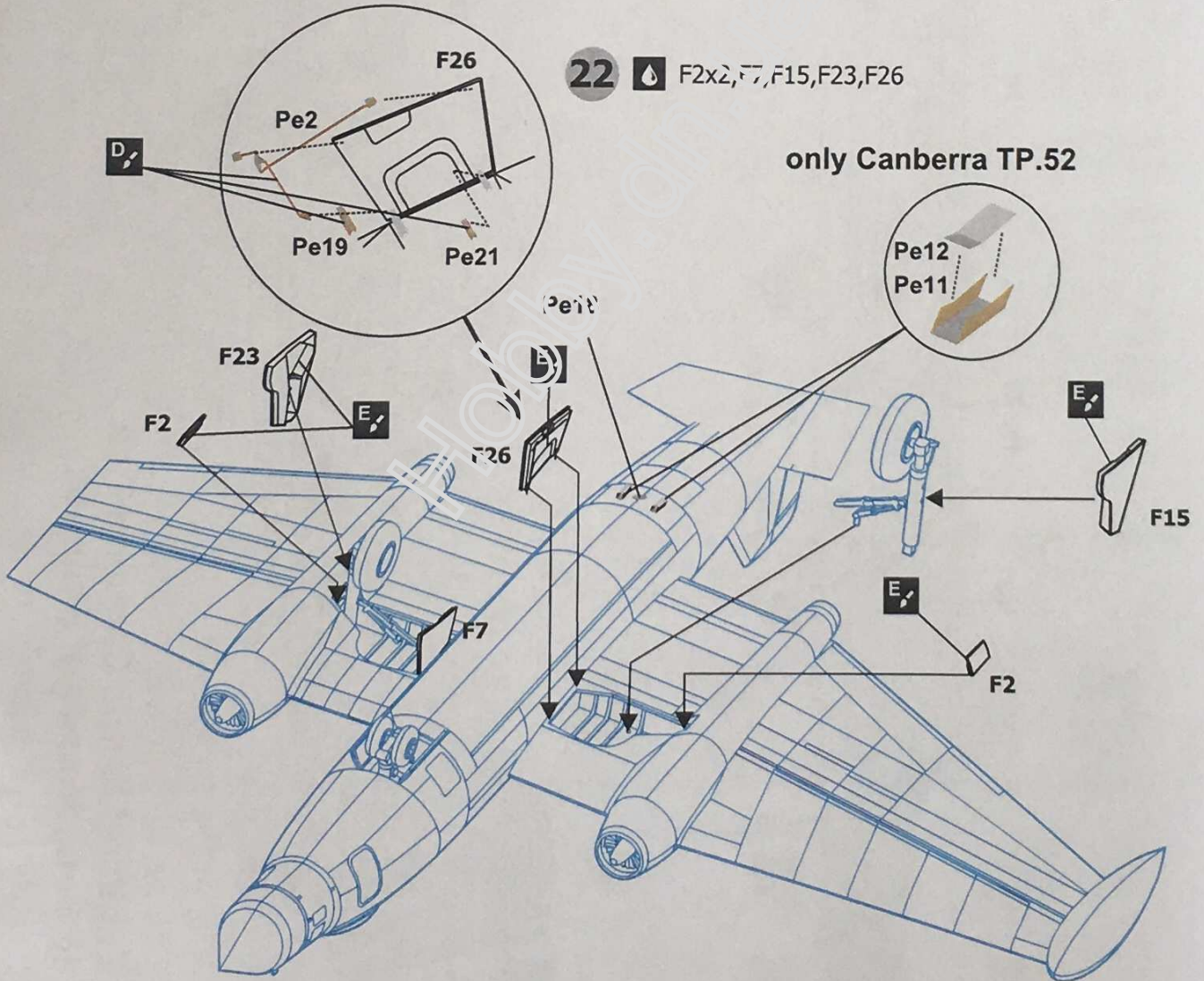

only Canberra TP.52

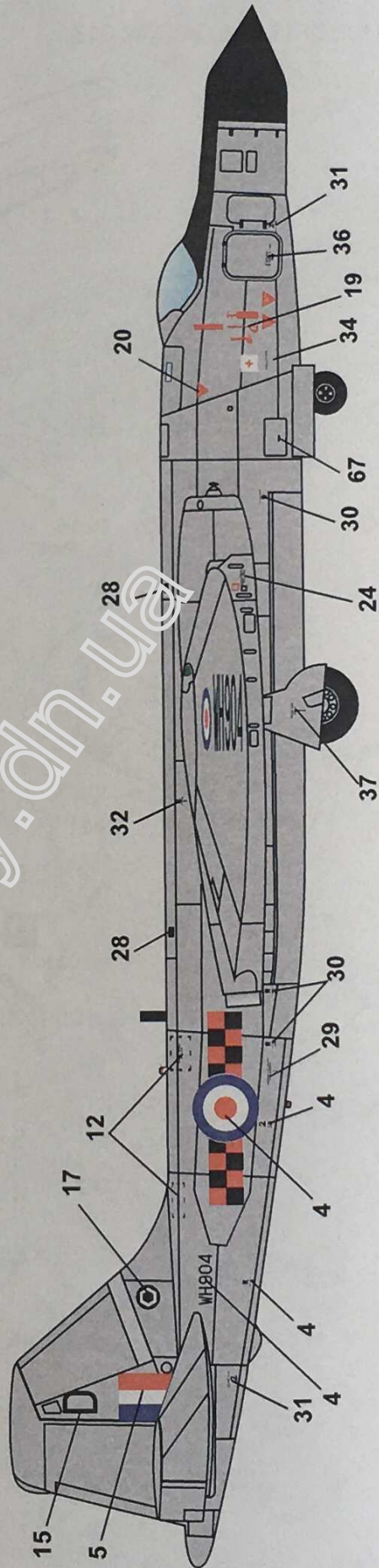
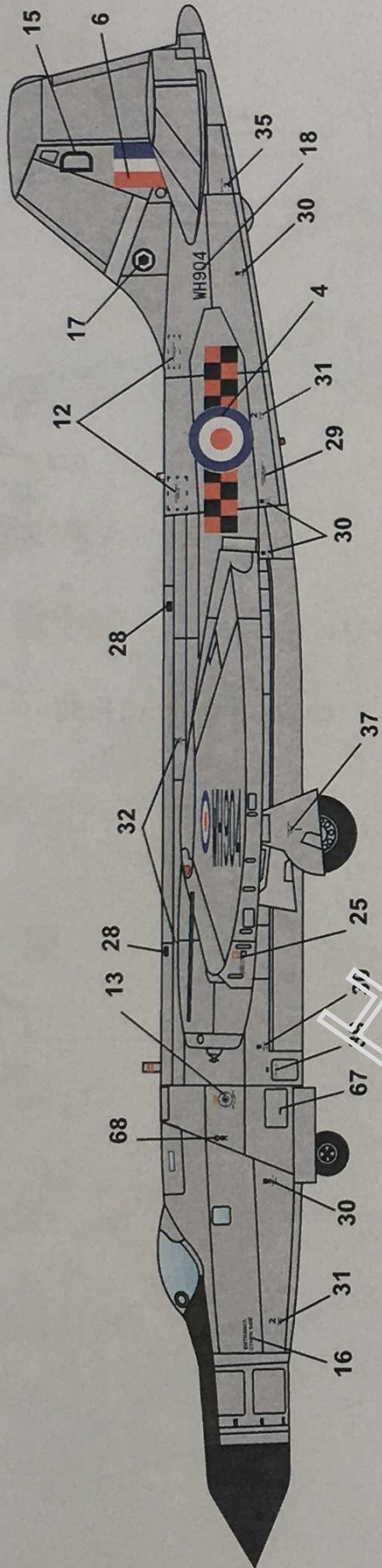

English Electric Canberra T.19
85 Squadron, RAF Binbrook

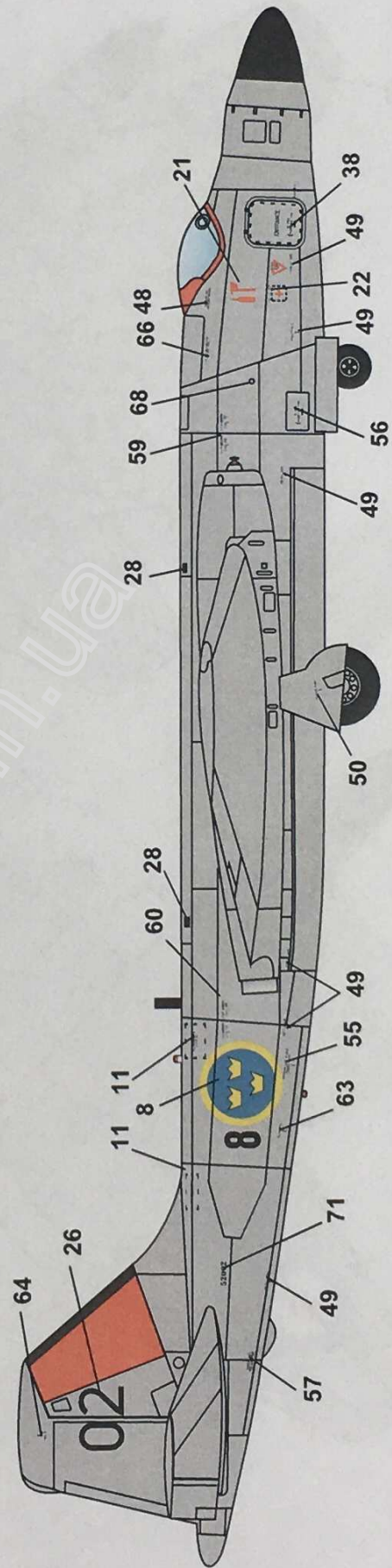
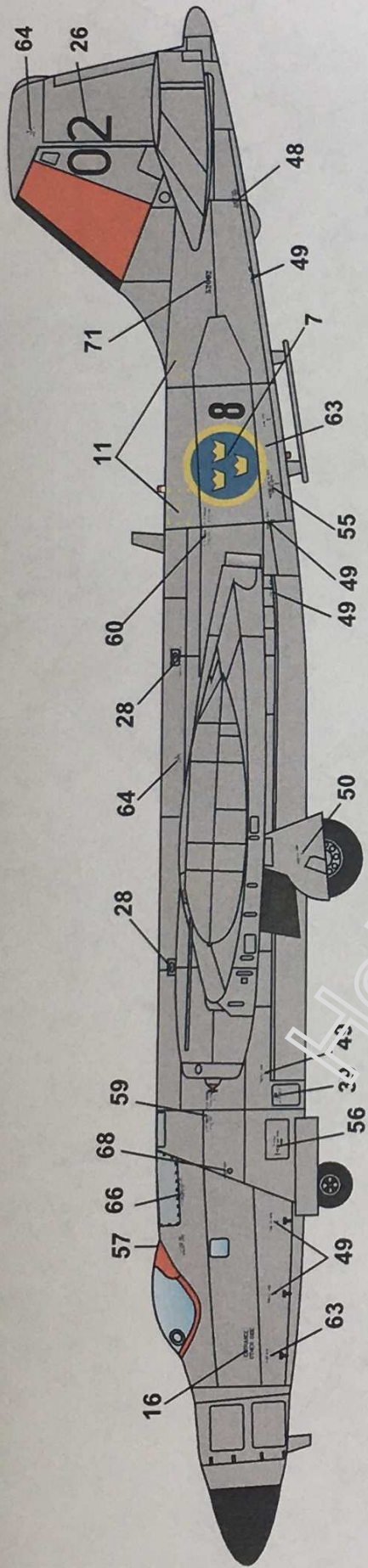

English Electric Canberra T.11(TP.52)
Swedish Air Force, 1960

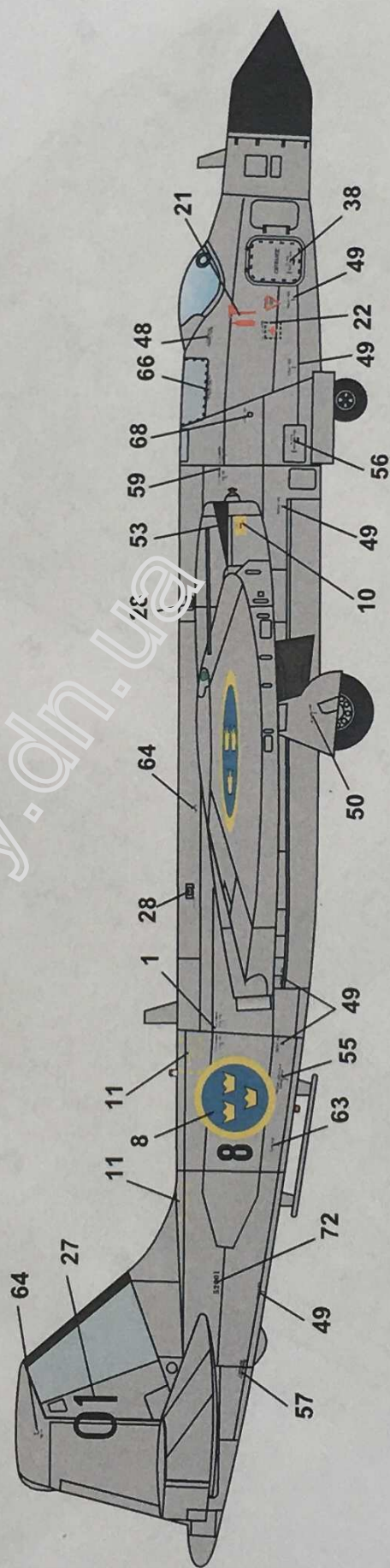
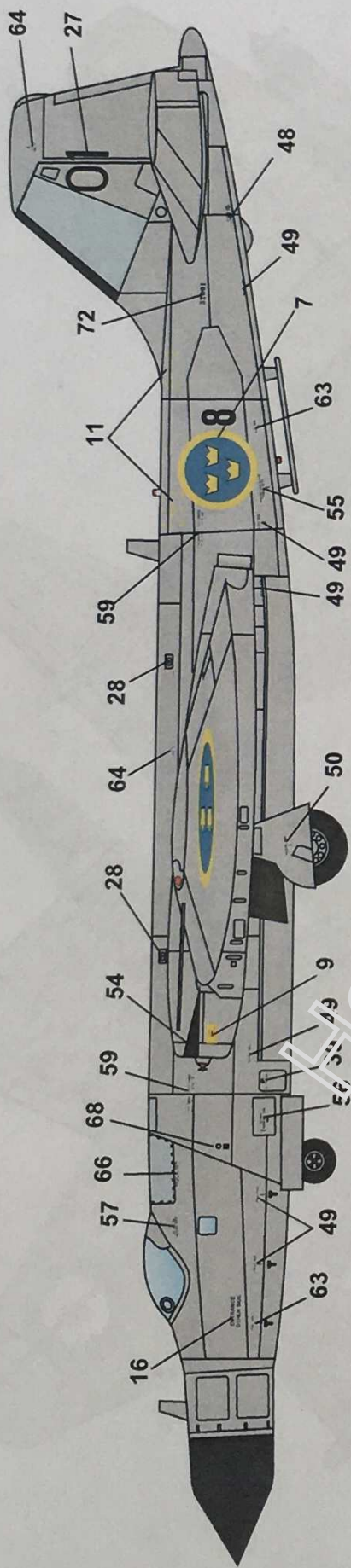

English Electric Canberra T.11(TP.52)
Swedish Air Force, 1960

