

AUTOBLINDO 1ZM

Scala 1/35

Manuale di Istruzioni



hobby.on.ua

Important Notes

- Read the instructions carefully before starting the assembly.
- Use glue intended for plastic models.
- Choking hazard. Keep small parts and plastic bags away from children.
- Always wear protective eyewear when cutting and a protective mask when painting, glueing and sanding.
- Use paints designed and suitable for plastic model kits.

Symbols Reference

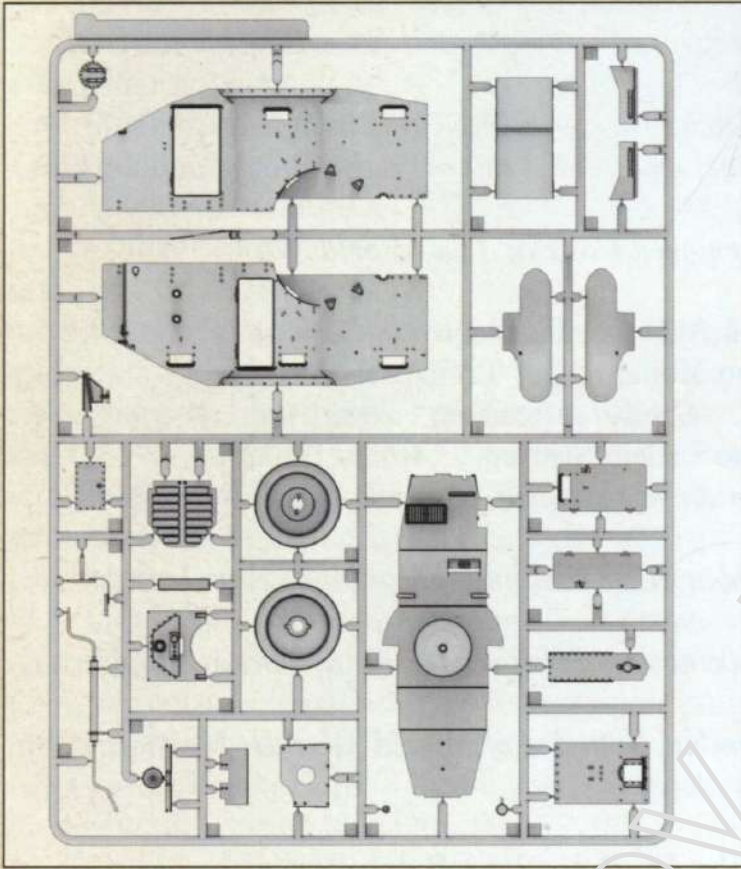
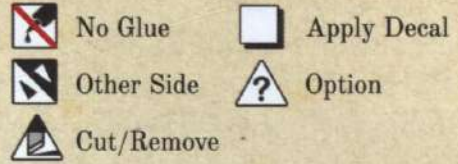

Fig. 1. Runner A

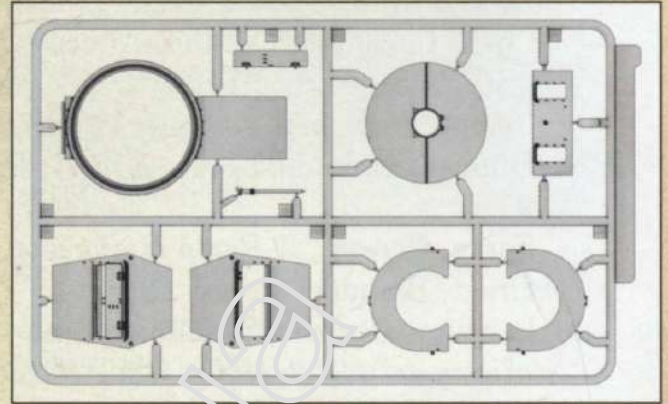

Fig. 2. Runner C

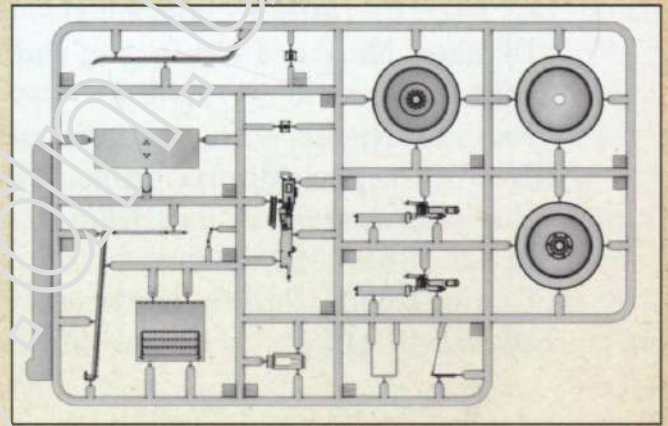

Fig. 3. Runner D, 2 pieces

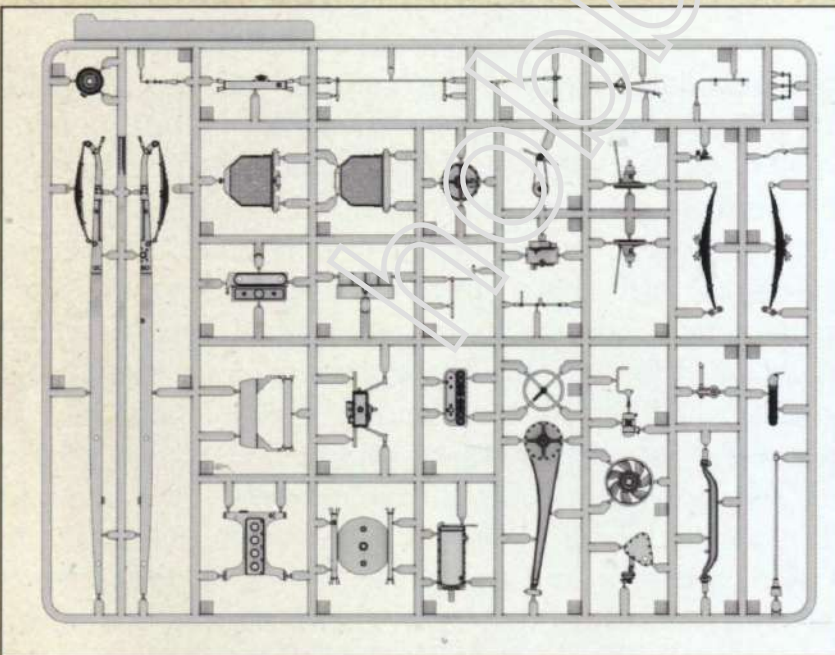

Fig. 5. Runner B

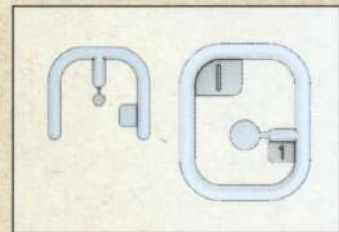

Fig. 4. Runners E and I

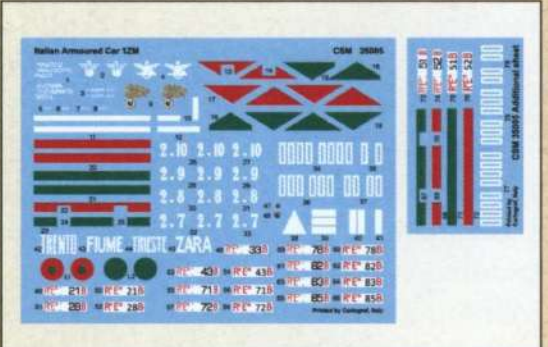
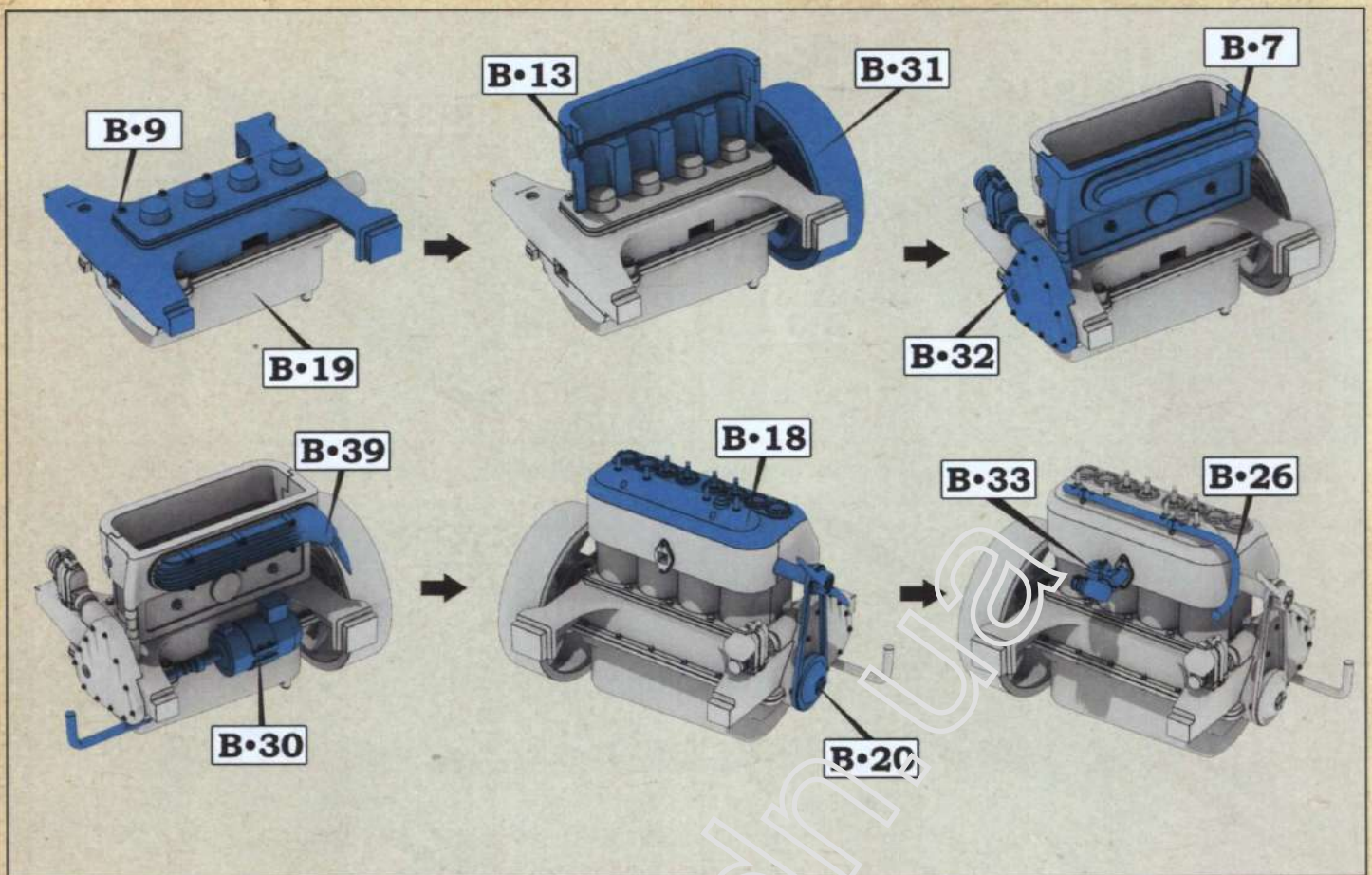

Fig. 6. Decals

Colour numbers

1 Burnt metal (exhaust)	4 Steel	7 Wood	10 Gun metal	13 Dark green	16 Rubber (dark)
2 Aluminum	5 Black	8 Leather	11 Rubber (light)	14 Grey green	
3 Copper	6 White	9 Brass	12 Light Green	15 Bakelite	



Step 1. Engine assembly

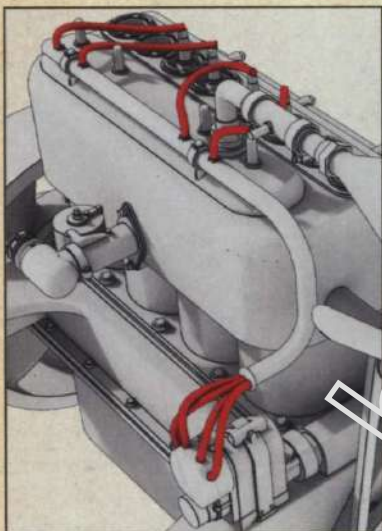

Fig 7. Engine wiring

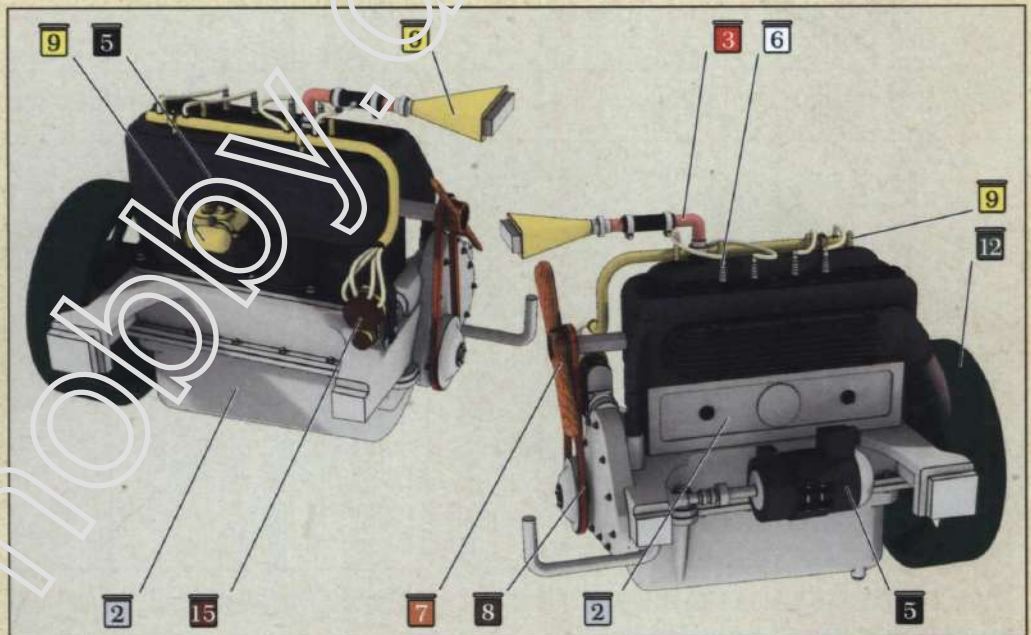
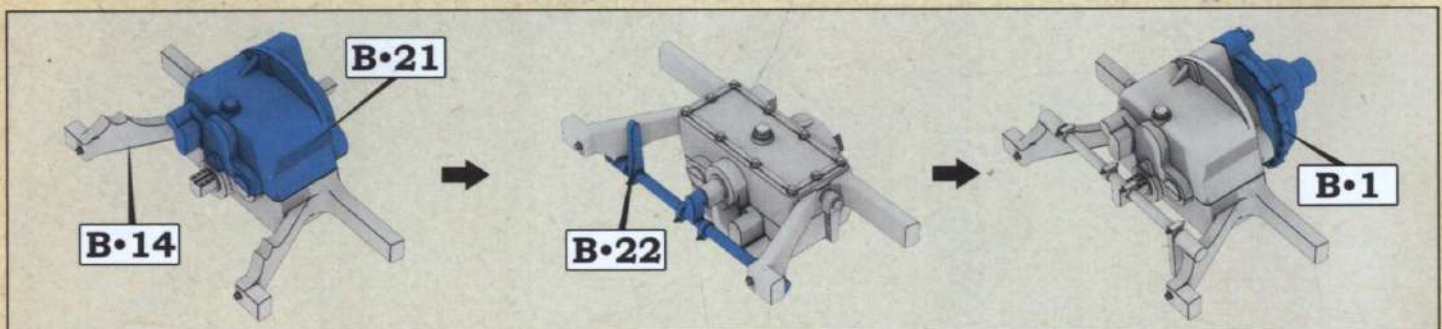
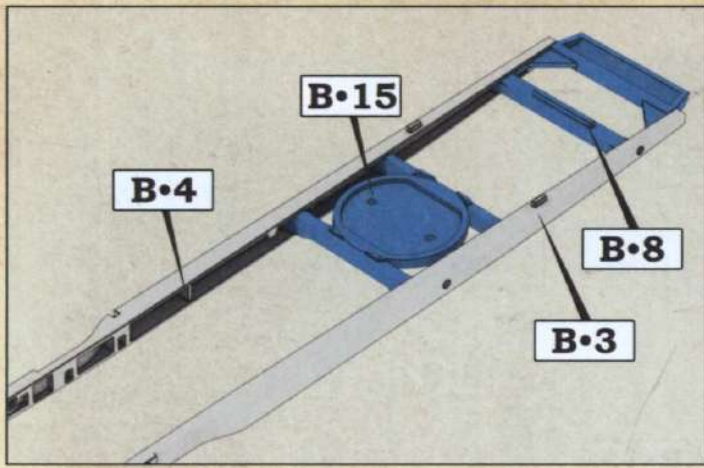

Fig 8. Engine assembly



Step 2. Gearbox assembly



Step 3. Installing both side rails and the cross members

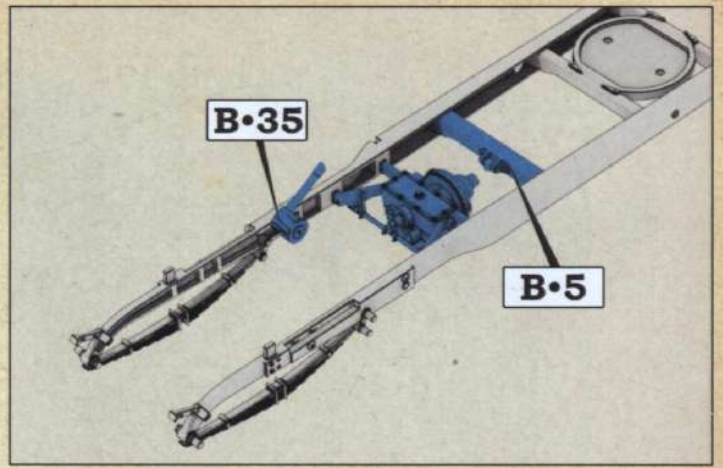

Step 4. Installing the steering gear, gearbox and other

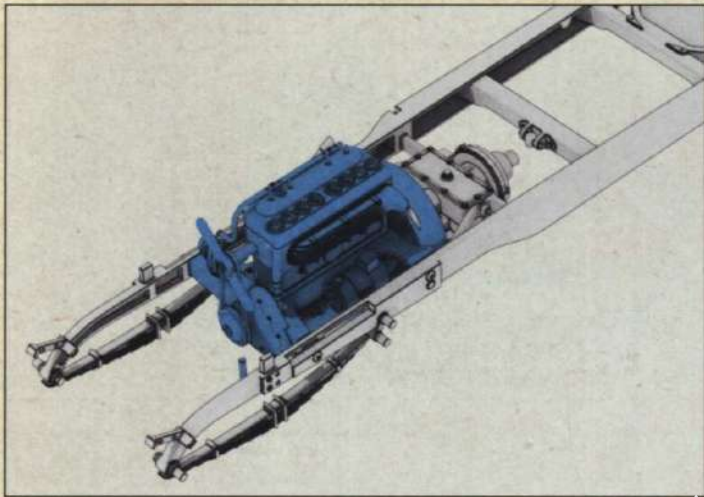

Step 5. Installing the engine

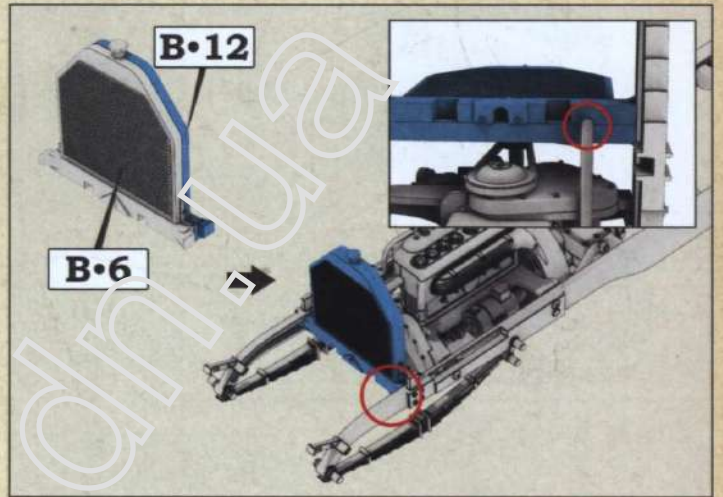

Step 6. Installing the radiator

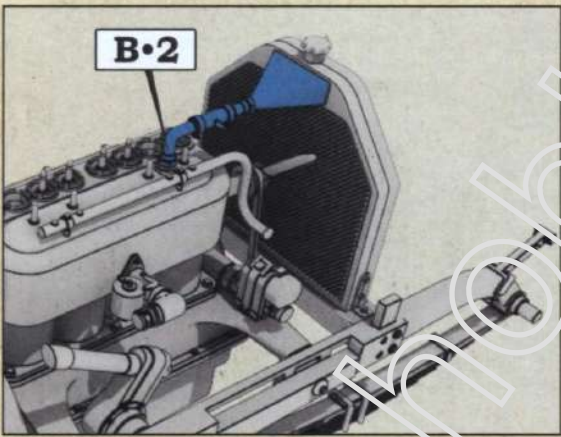

Step 7. Installation of the radiator pipe

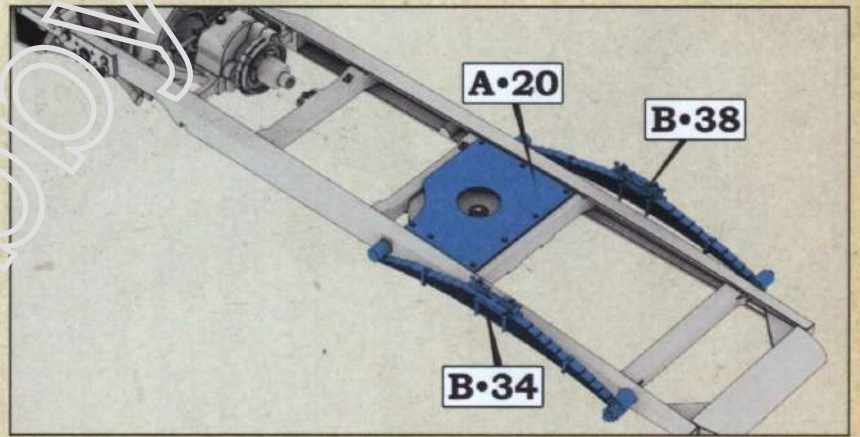

Step 8. Installation of the rear leaf springs and fuel tank protection

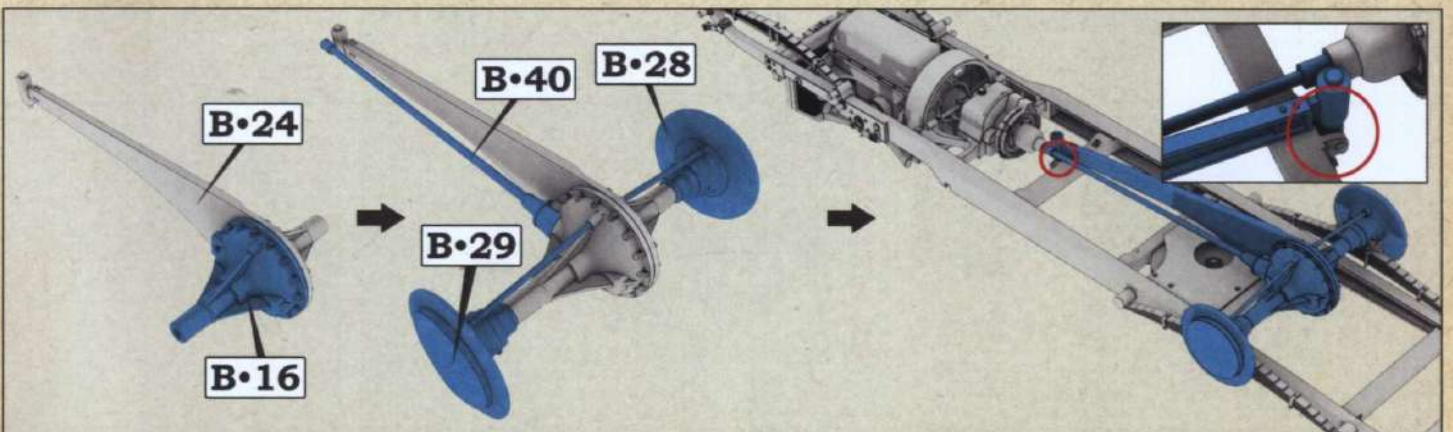

Step 9. Assembling and installation of the rear axle

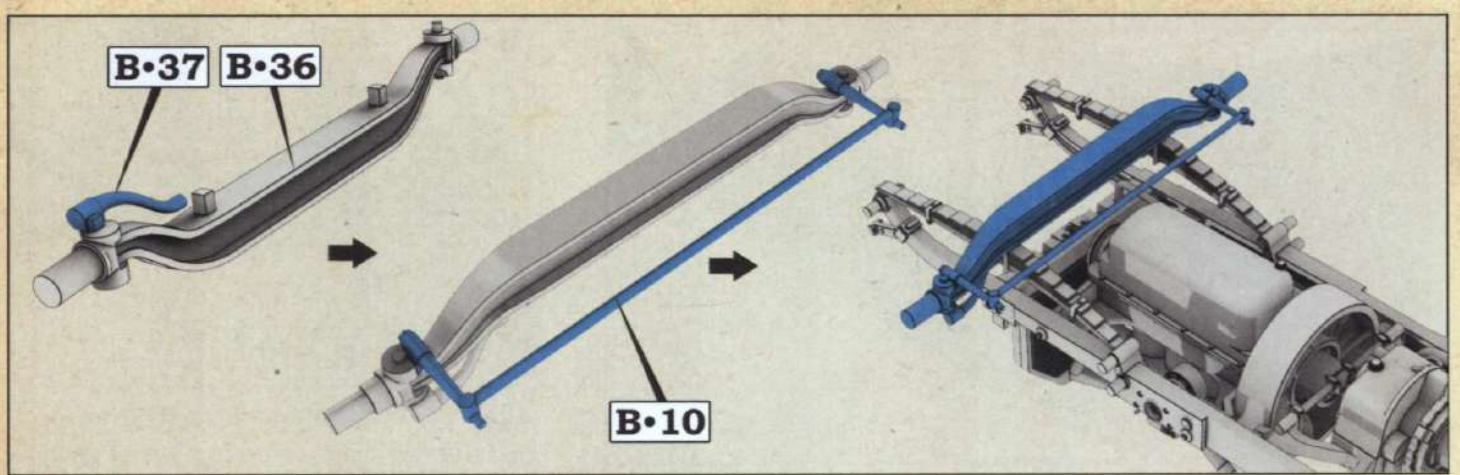

Step 10. Assembling and installation of the front axle

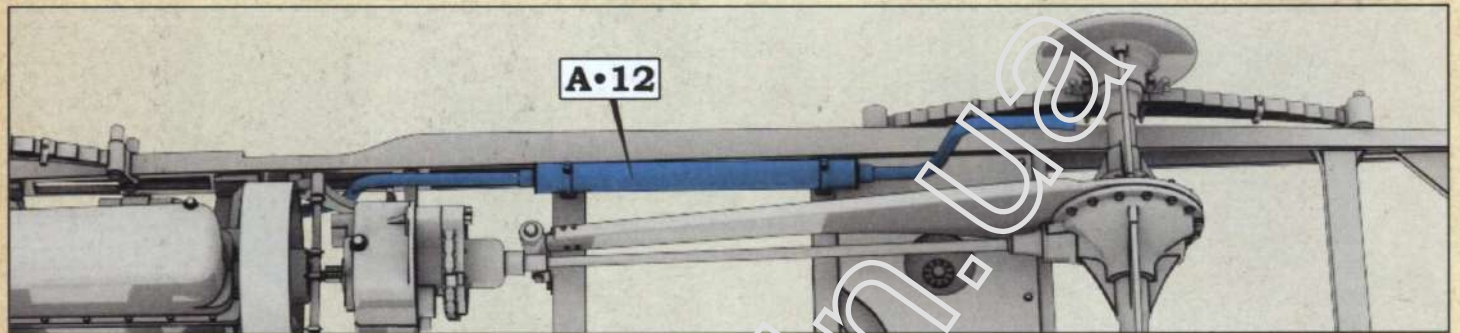

Step 11. Installation of the exhaust pipe with muffer

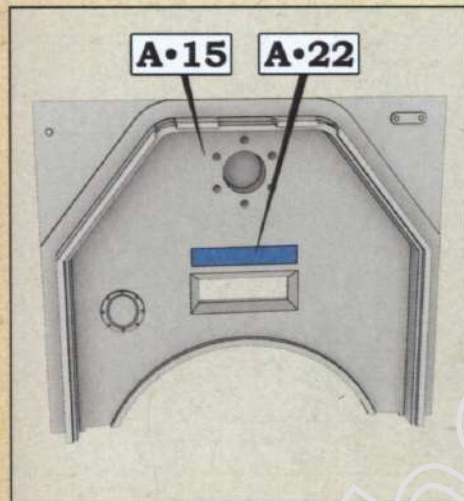

Step 12. Filling the hole

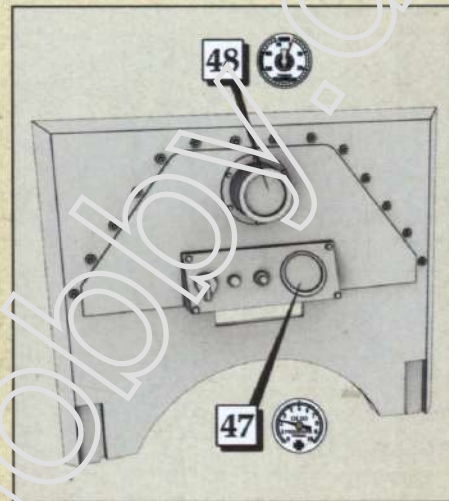

Step 13. Applying the decals

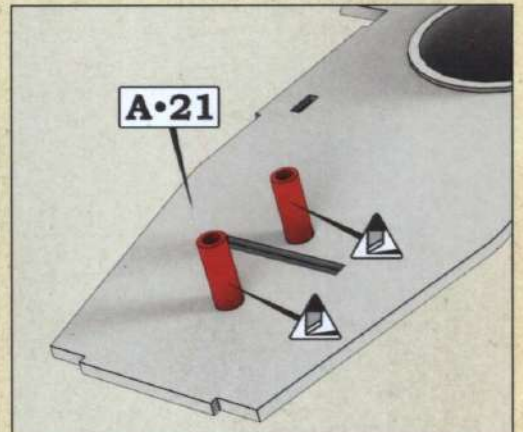

Step 14. Remove the pins for markings page 18-21,23 (except 2.9 markings version) and pages 24-25

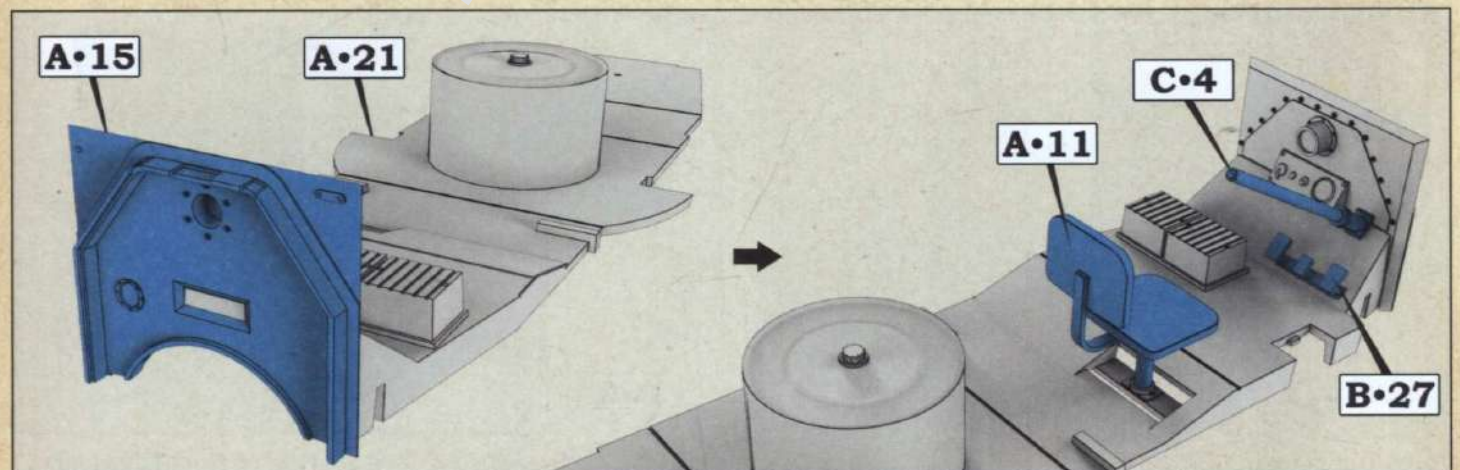

Step 15. Assembling the interior parts

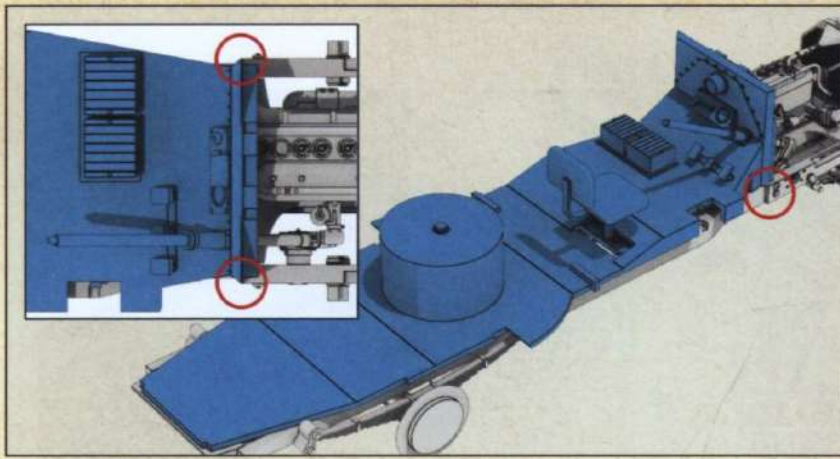

Step 16. Installing the floor with the interior. **Check the alignment**

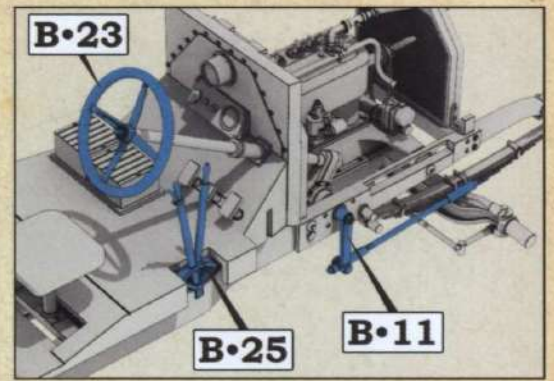

Step 17. Installation of the gear and handbrake levers, steering wheel and the steering arm

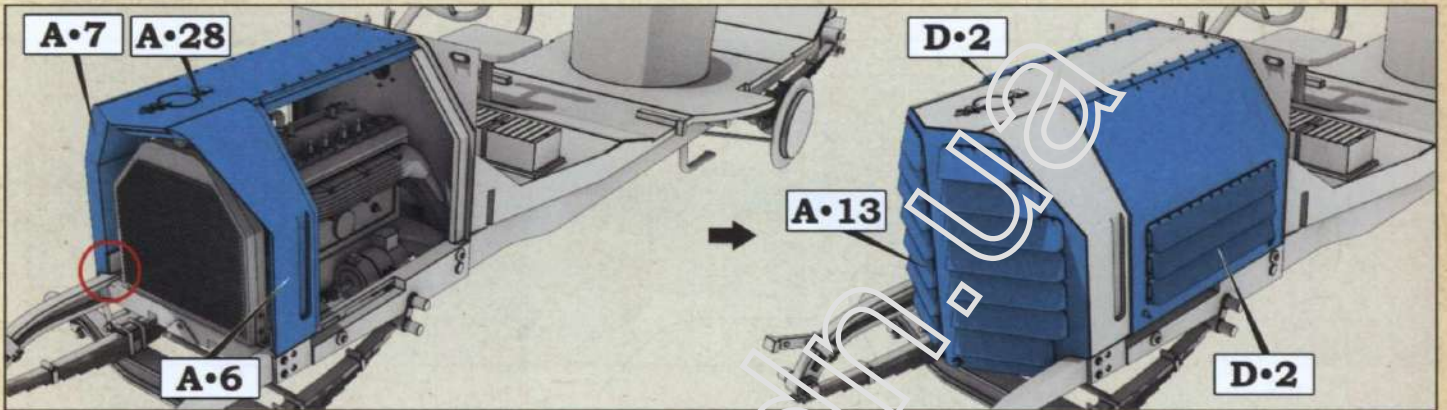

Step 18. Installation of the radiator and engine armour

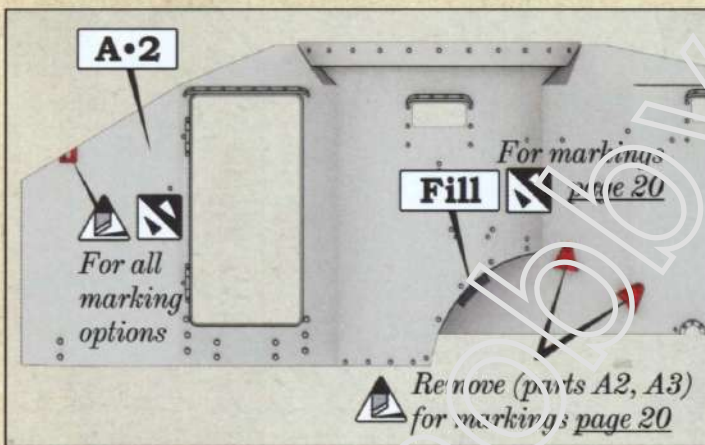

Step 19. Additional actions for A2 and A3

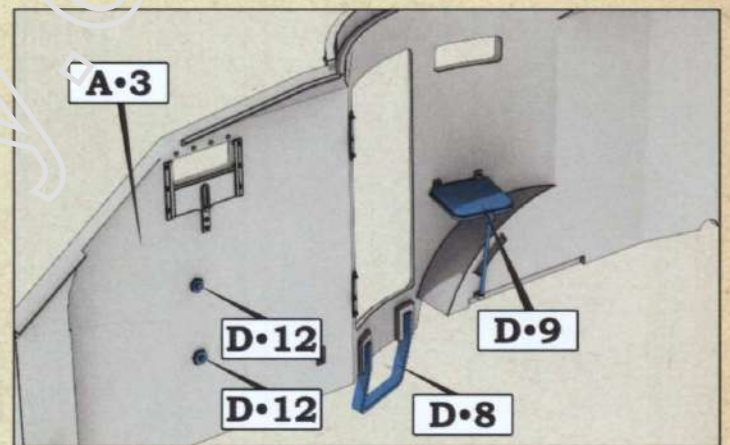

Step 20. Starboard armour interior parts

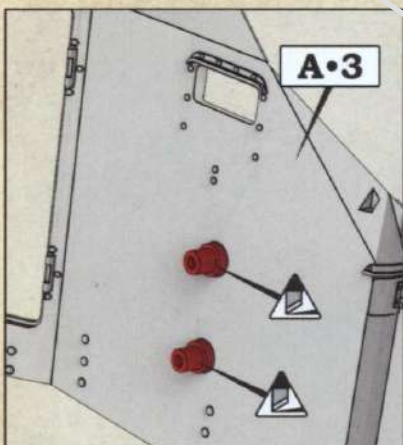

Step 21. Remove (and fill) the pins for markings page 21,22 and specific 1ZM on page 23

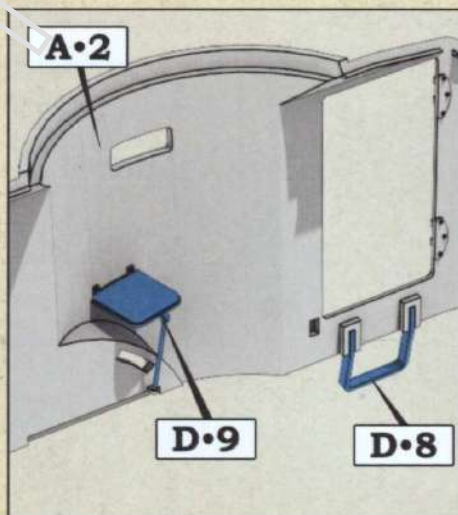

Step 22. Port armour interior parts

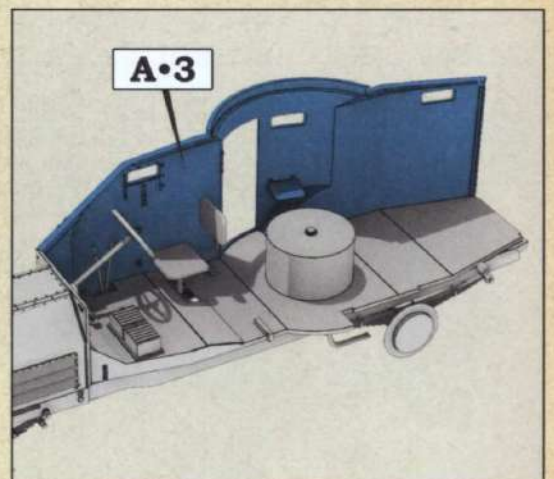

Step 23. Installation of the starboard armoured superstructure wall

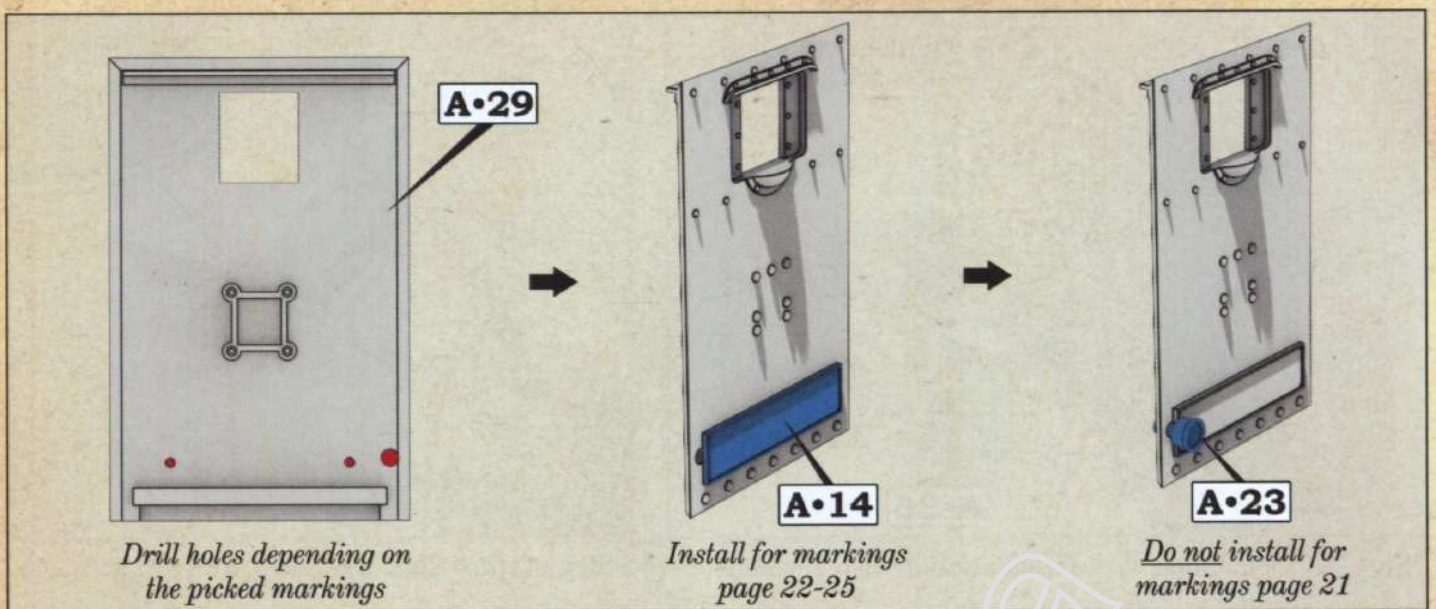

Step 24. Assembling of the armoured superstructure rear wall

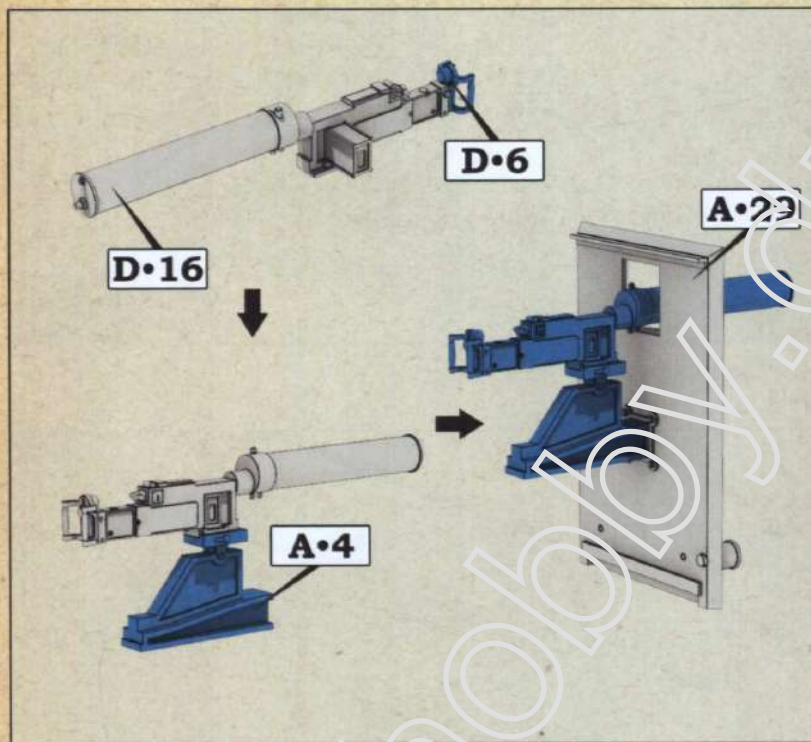

Step 25. Installation of the rear MC. Only for markings page 19, 20, 22-25

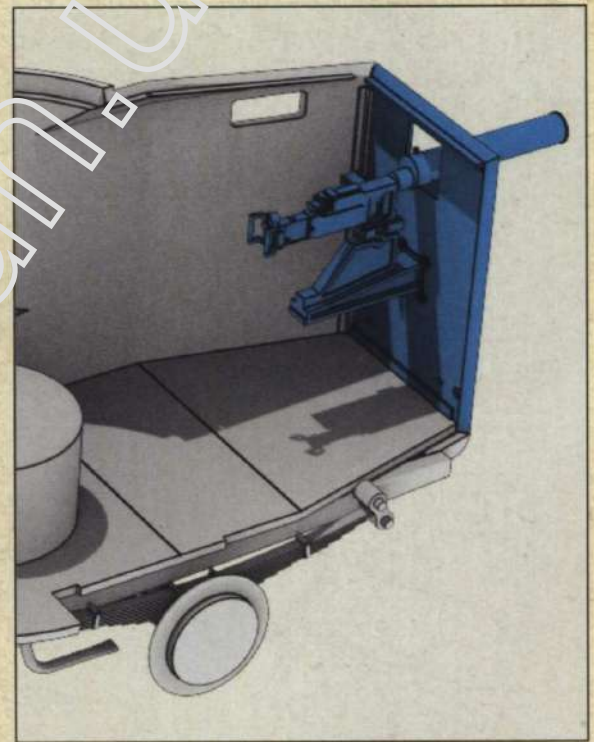

Step 26. Installation of the armoured superstructure rear wall

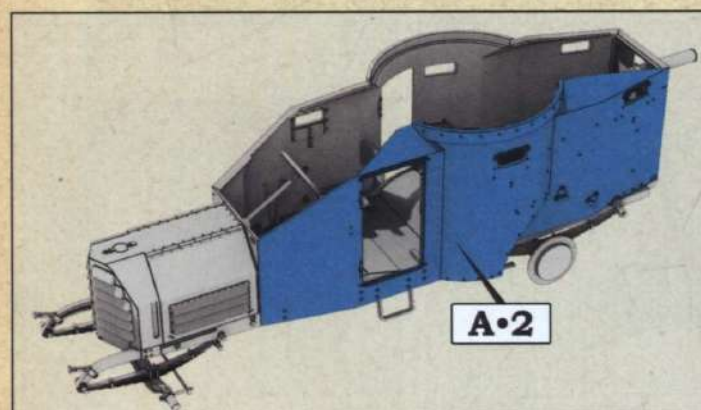

Step 27. Installation of the port armoured superstructure wall

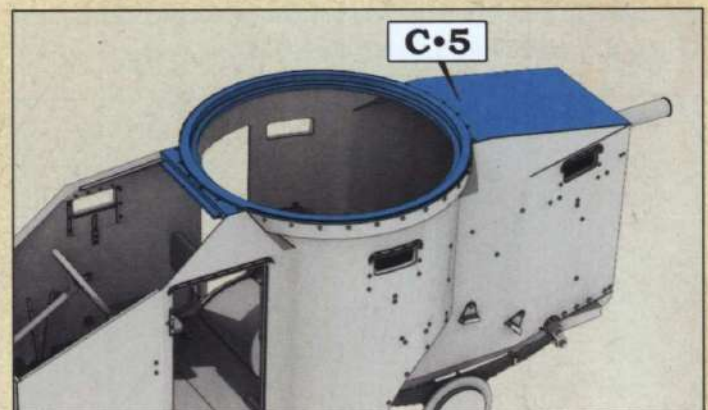

Step 28. Installation of the armoured roof

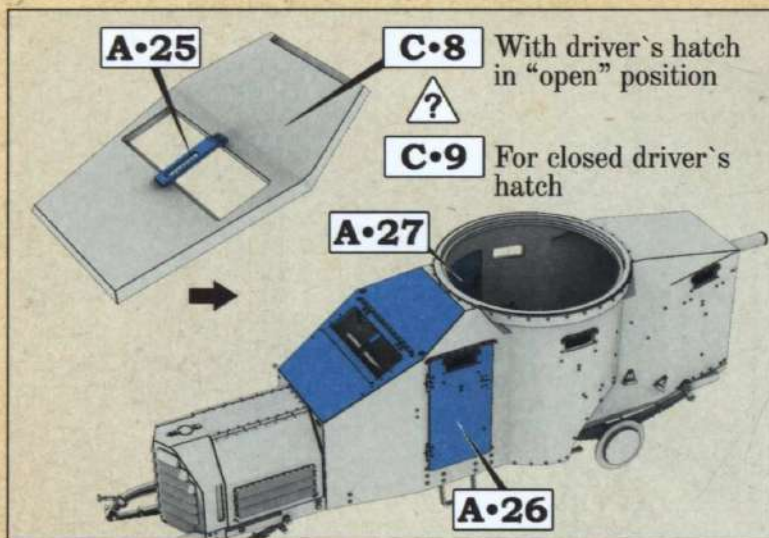

Step 29. Installation of the front armoured plate and doors

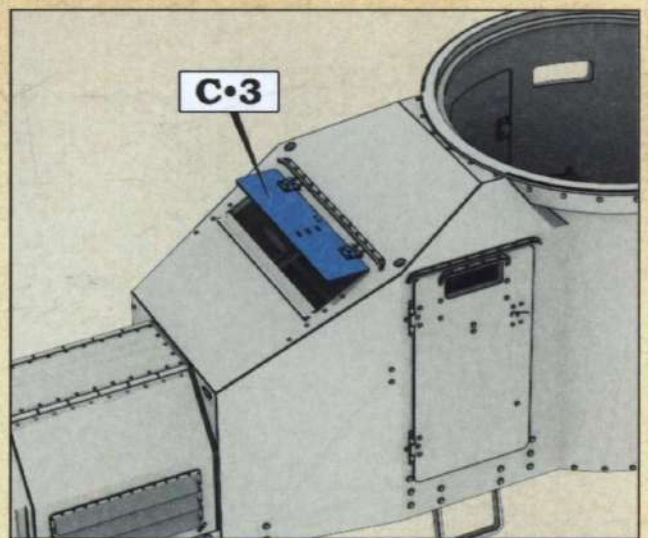

Step 30. Installation of the driver's hatch

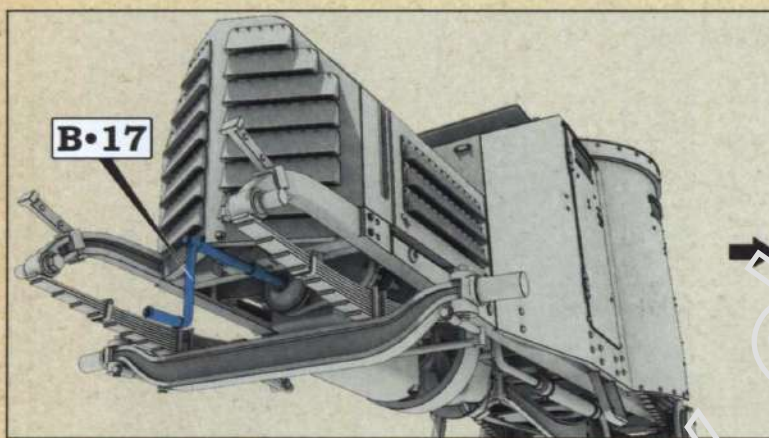

Step 31. Installing the hand crank and the radiator lower armoured plate

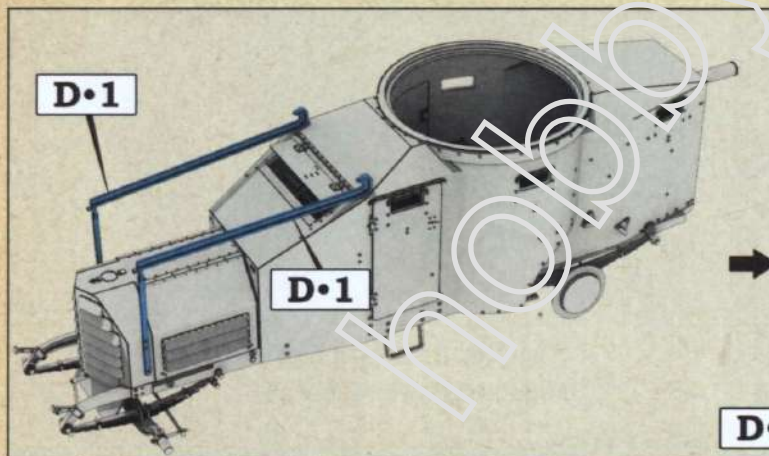

Step 32. Installing the wire cutters

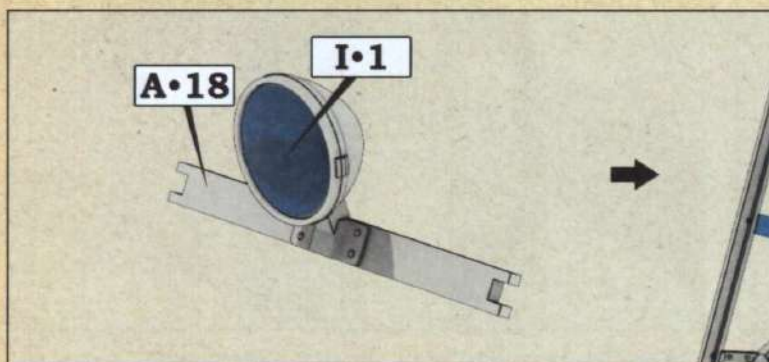
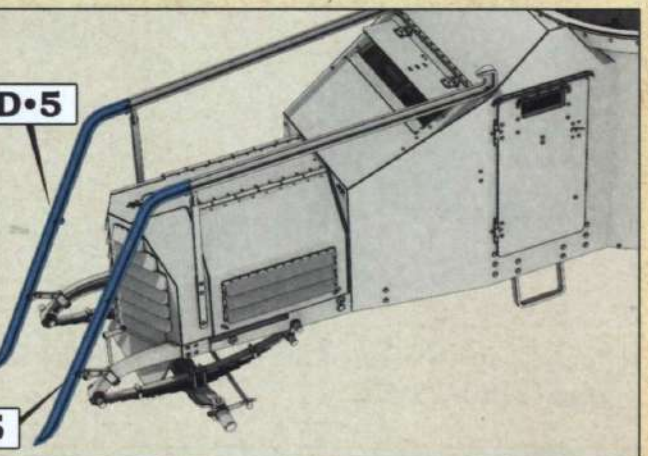

Step 33. Installation of the headlamp

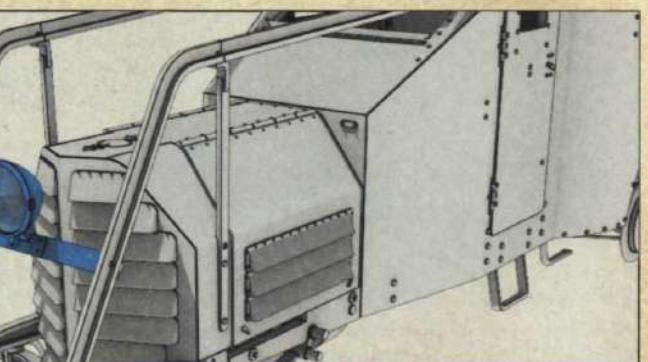

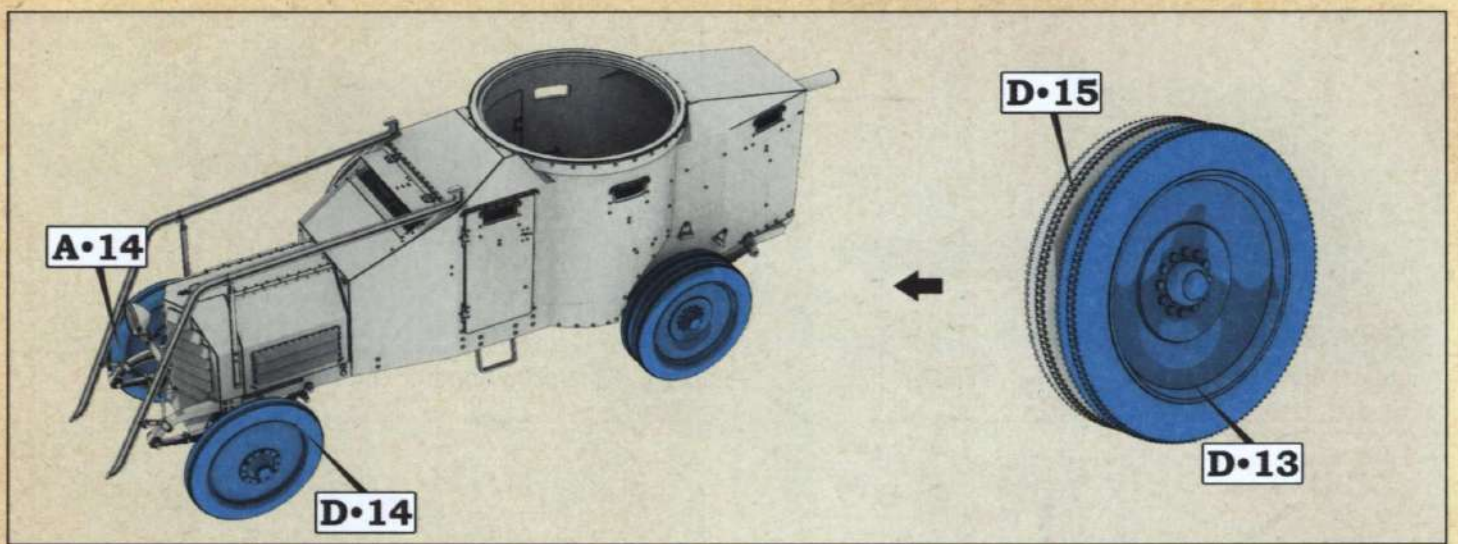

Step 34. Installation of the wheels

Step 35. Installation of the front and rear fenders. Skip for markings page 20 on both sides of the car

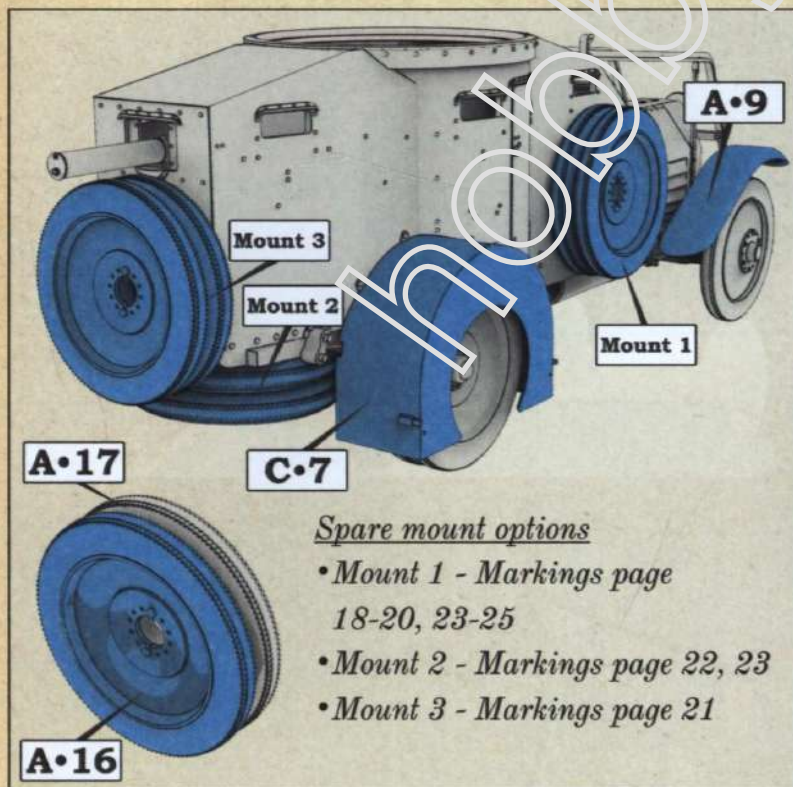
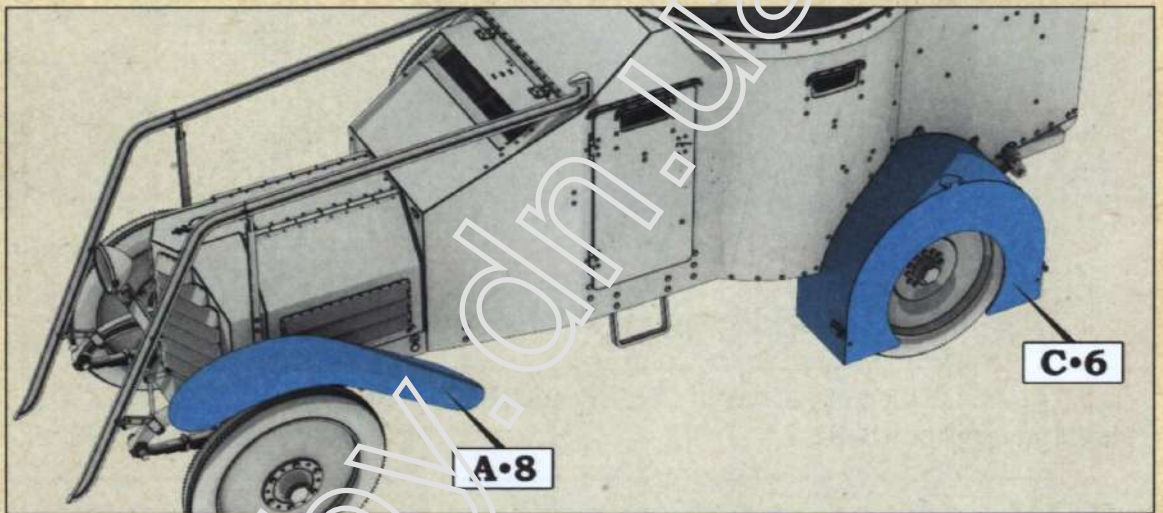

Step 36. Installation of the front and rear fenders and the spare. Do not install C7 and A9 for markings page 20

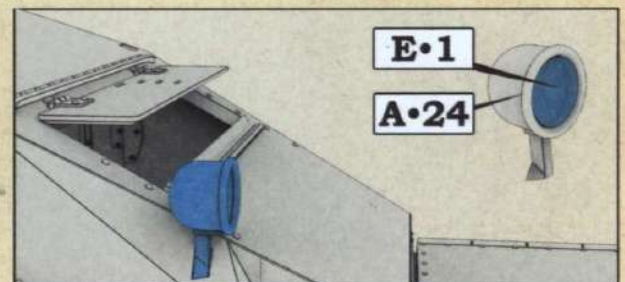

Step 37. Installation of the side lamp

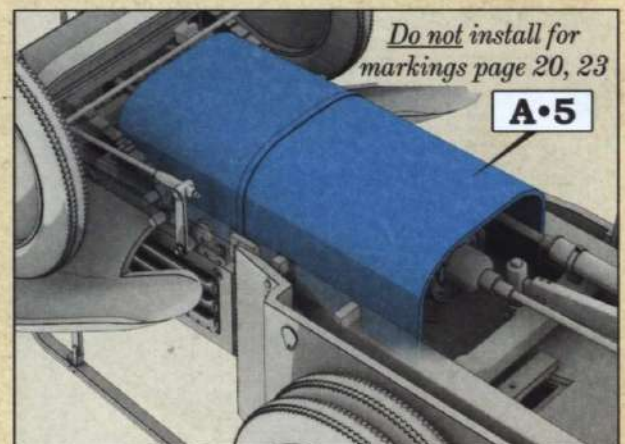

Step 38. Installation of the engine protection

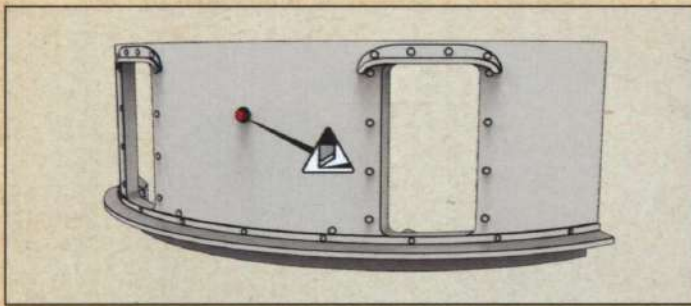

Step 39. Remove the hex head bolt for markings page 19-22, 24, 25

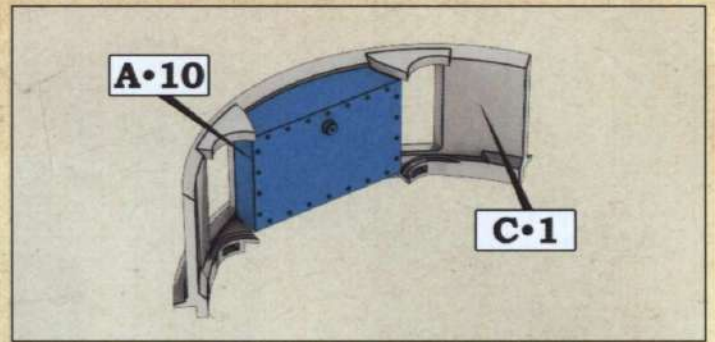

Step 40. Assembling of the turret's front wall

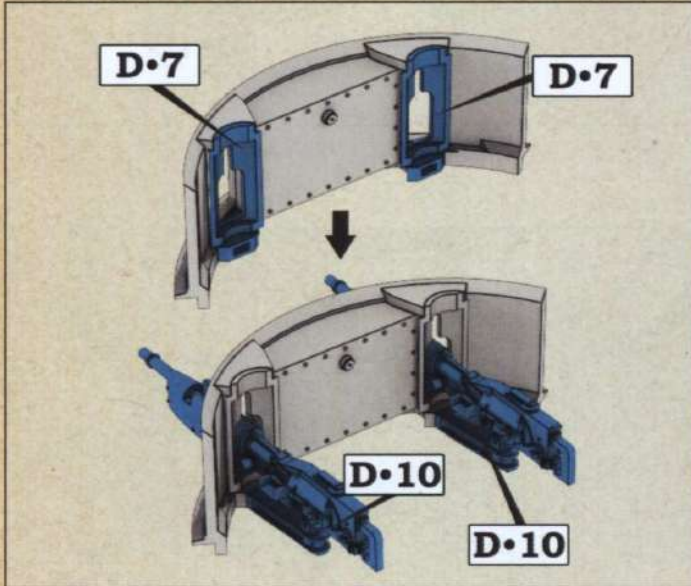

Step 41a. Installation of the turret's St. Étienne MG for markings page 18, 21

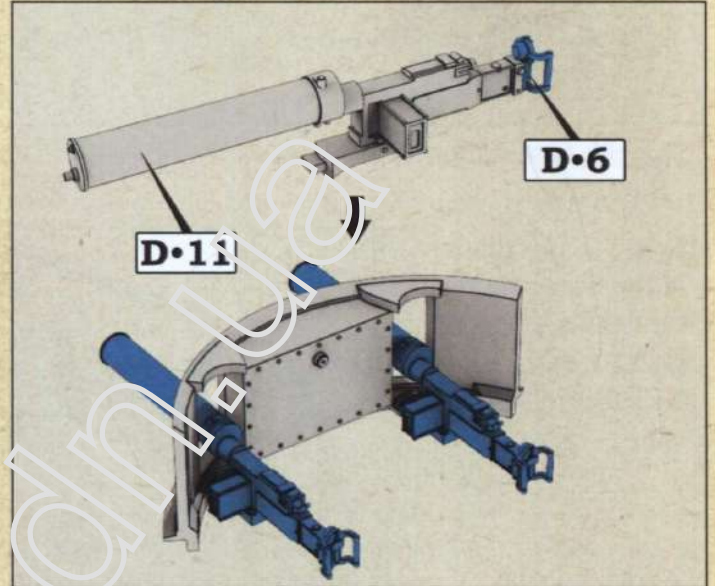

Step 41b. Installation of the turret's Fiat-Revelli MG for markings page 19, 20, 22-25

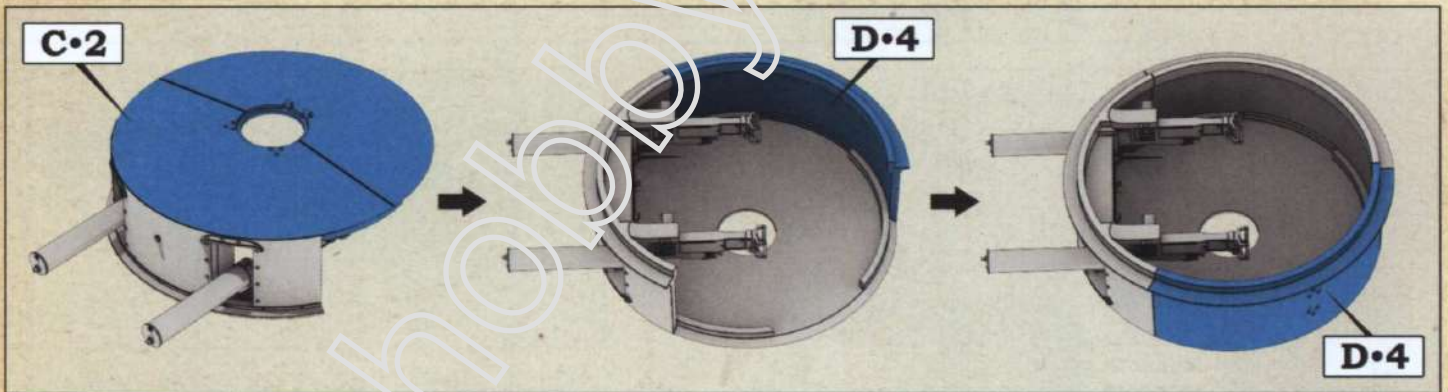

Step 42. Assembling the turret

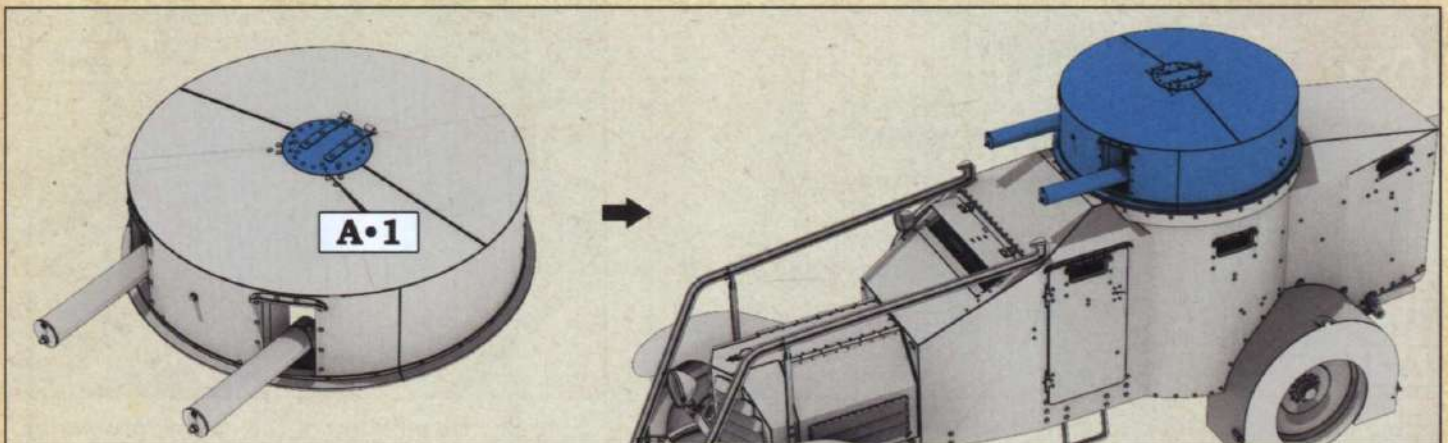

Step 43. Installation of the turret

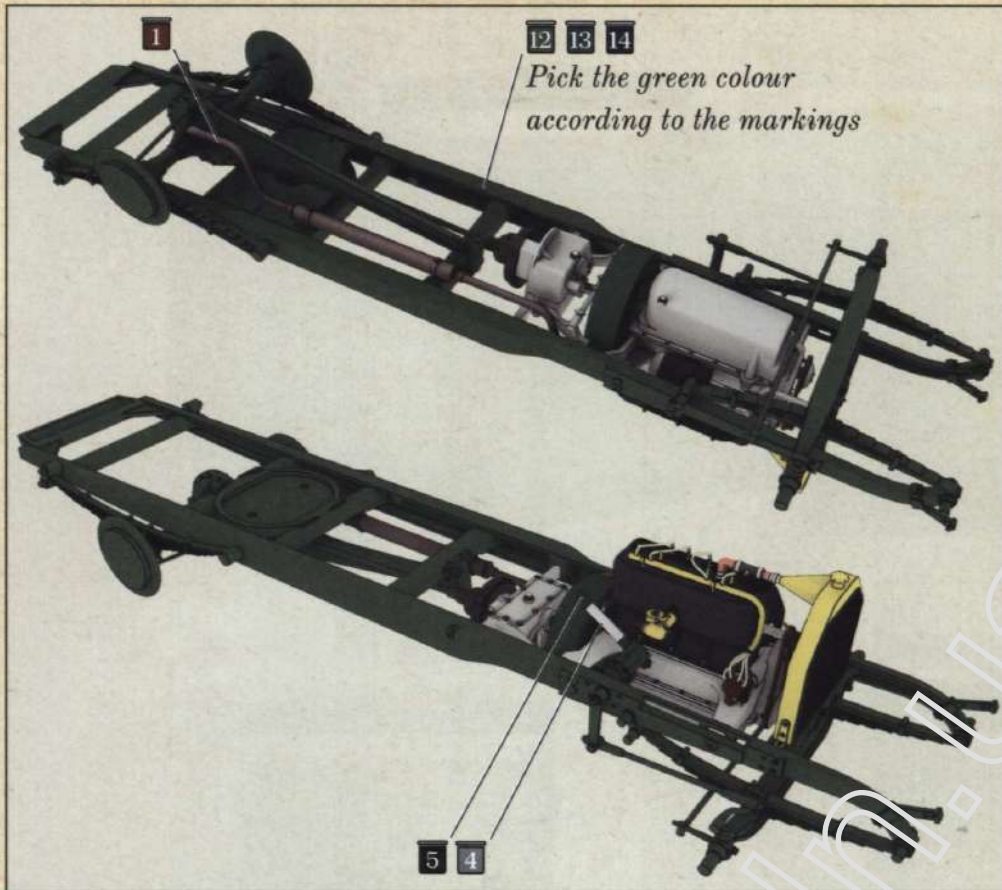

Fig. 8. Colours for the chassis

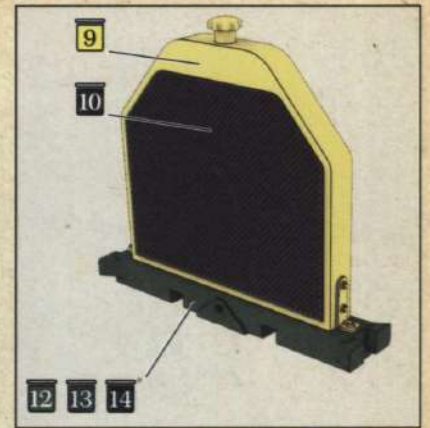

Fig. 9. Radiator colours



Fig. 10. Dashboard



Fig. 11. Interior colours



Fig. 12. Engine compartment



Fig. 13. Machine guns

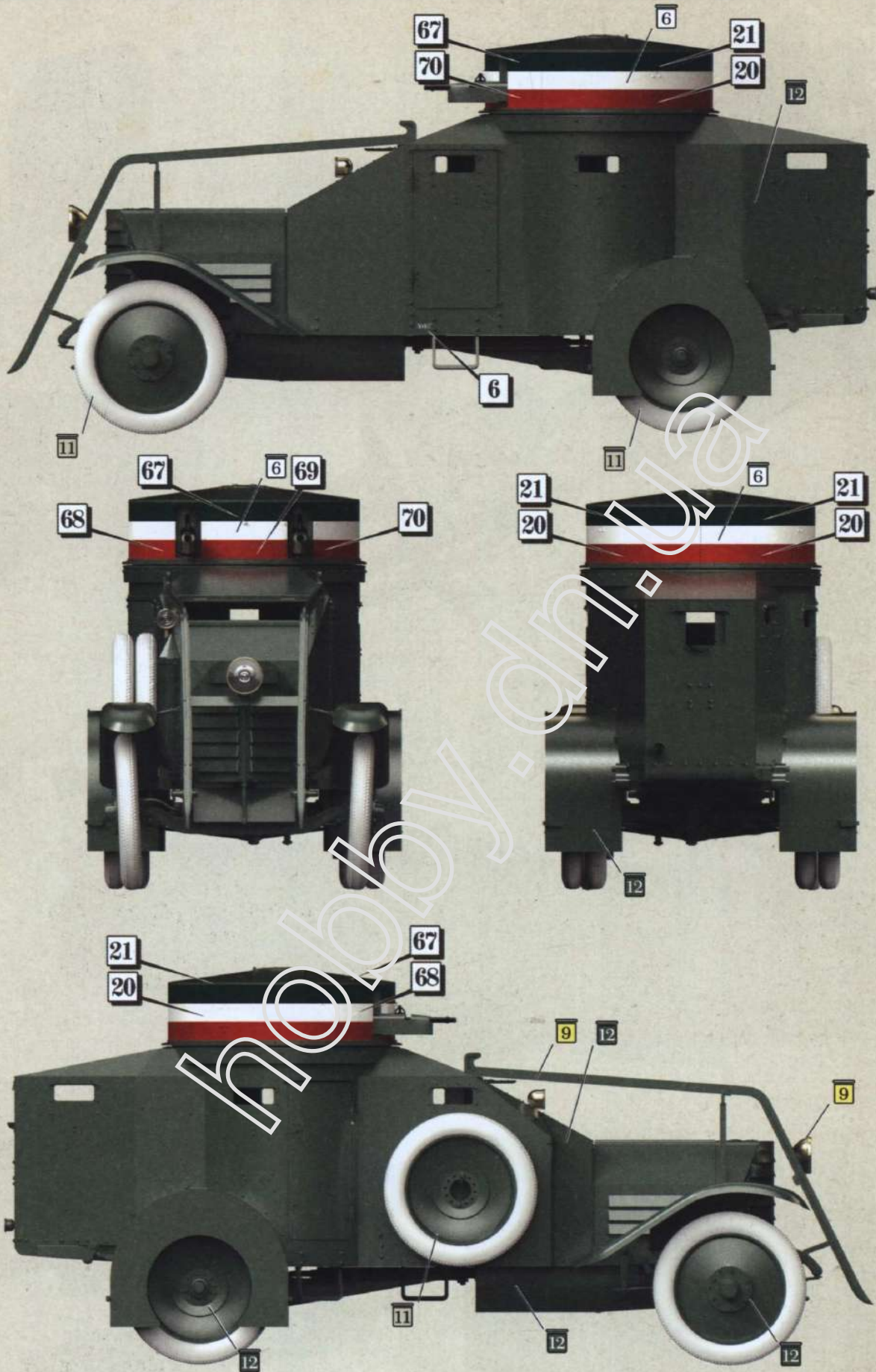
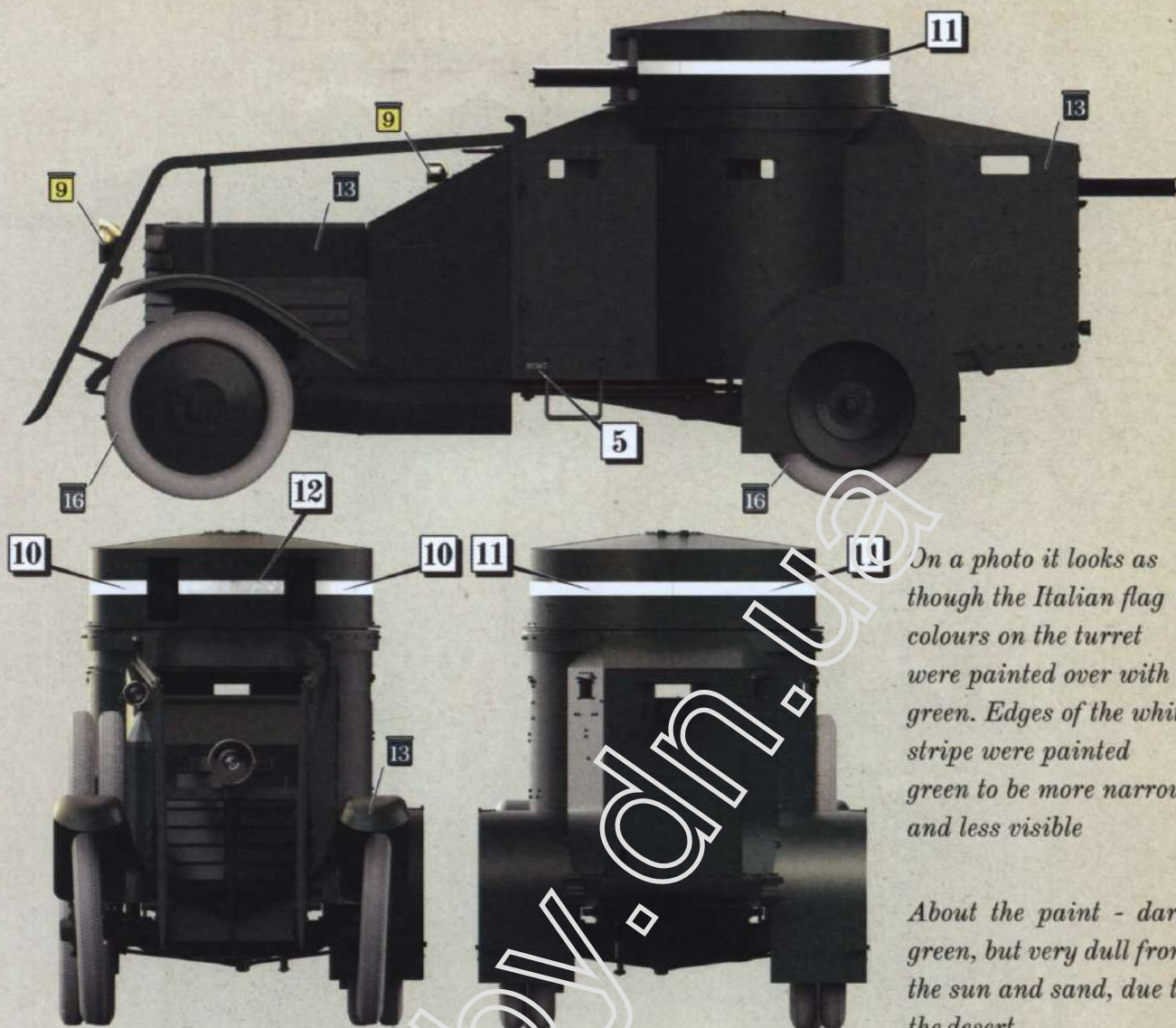

Fig. 14. National colours on the turret, for all Lancias in the Army's Squadrone, from late 1917 to November 1918. Some squadrons had only Fiat Revelli MG-equipped vehicles, others only St. Etienne, some had a mix of both vehicles. Squadrons 3rd, 4th, 5th, 7th, 8th, 9th, 10th, 11th, 14th, 15th, and 16th were equipped with the St. Etienne MG on their Lancias



On a photo it looks as though the Italian flag colours on the turret were painted over with green. Edges of the white stripe were painted green to be more narrow and less visible

About the paint - dark green, but very dull from the sun and sand, due to the desert

Fig. 15. 2nd Squadron, 3rd "Cacciatori d'Africa" (Africa's Light Infantry), Berka barracks, Benghazi, Libya January 1923

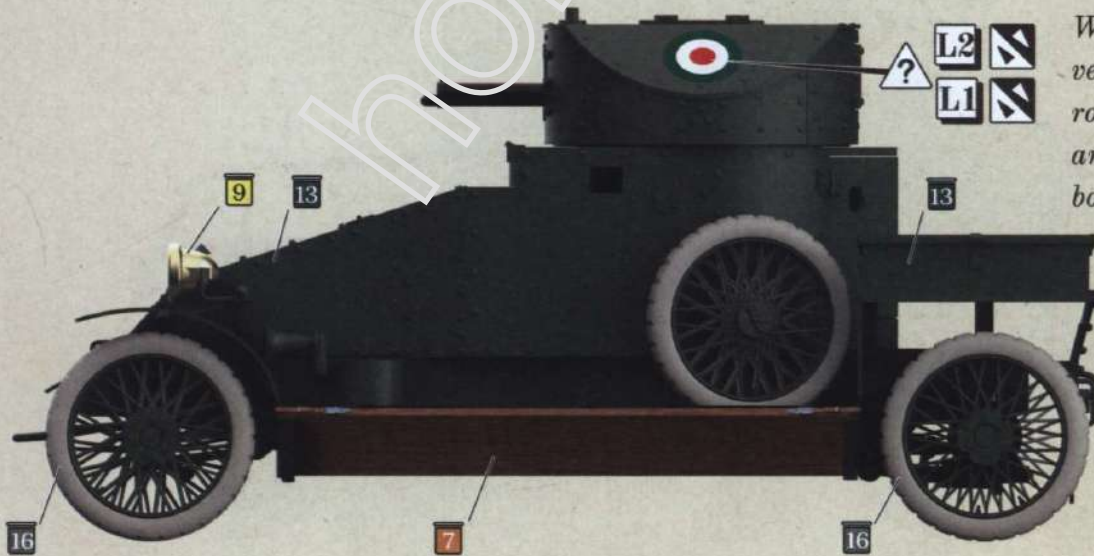

We do not know which version of the Italian roundel was applied, and so, we are offering both.

About the paint - dark green, but very dull from the sun and sand, due to the desert

Fig. 16. 2nd Squadron, 3rd "Cacciatori d'Africa" (Africa's Light Infantry) Lanchester armoured car Berka barracks, Benghazi, Libya January 1923

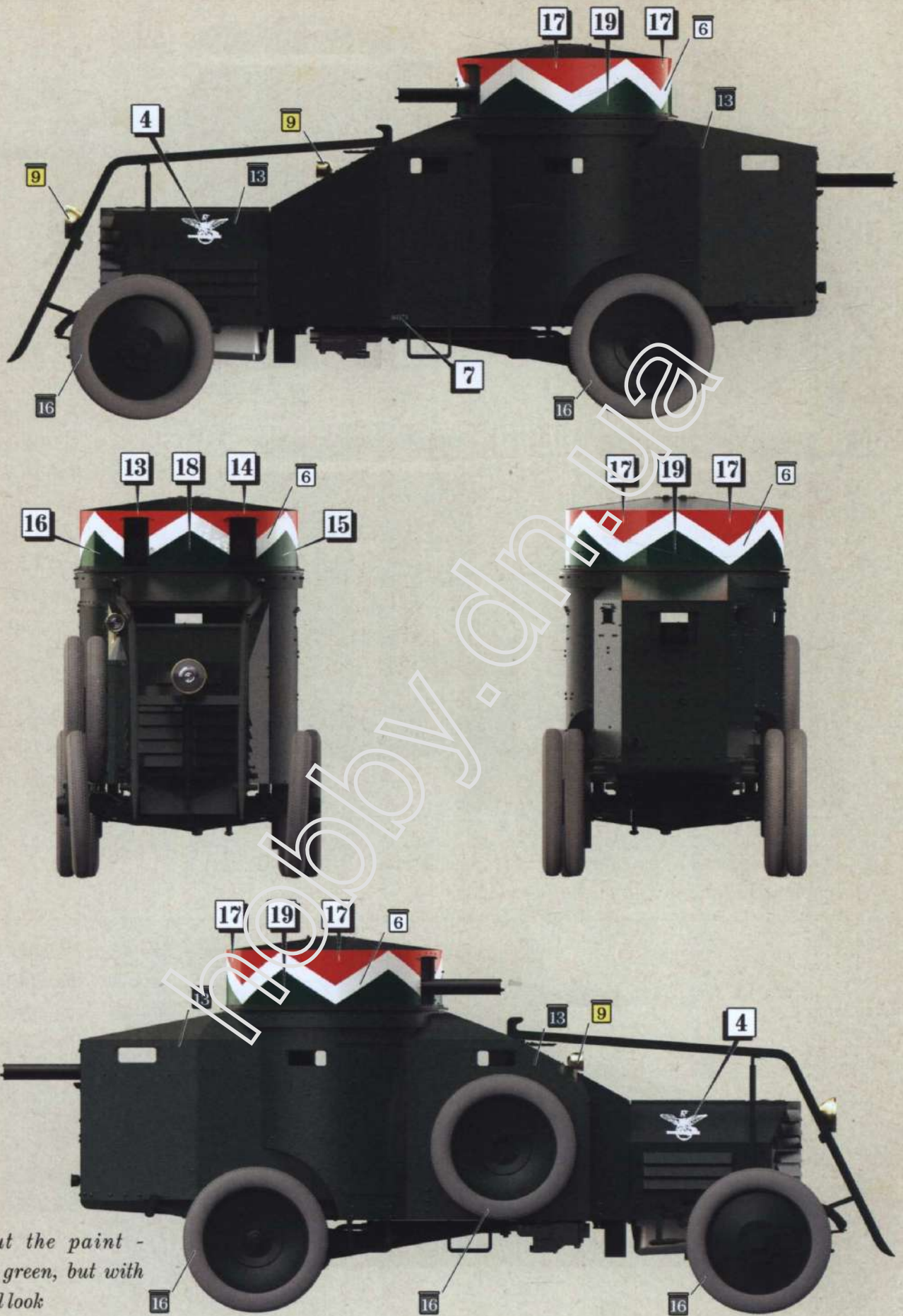

*About the paint -
dark green, but with
a dull look*

Fig. 17. 5th Section, 1st Squadron RCTC (Royal Colonial Troops) – Libya, May 1931

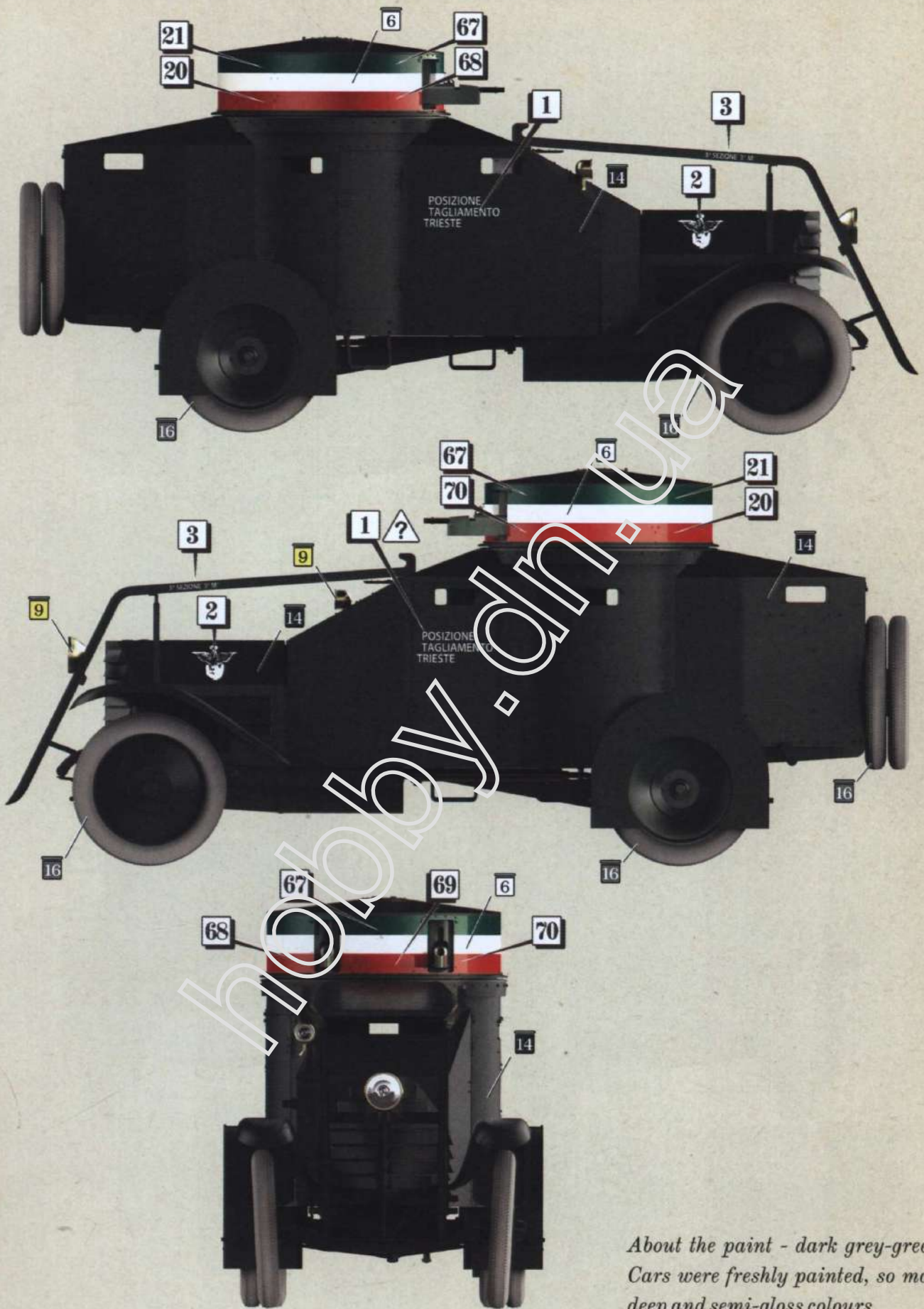

*About the paint - dark grey-green.
Cars were freshly painted, so more
deep and semi-gloss colours*

Fig. 18. 3rd Section, Regia Guardia (Royal Guard), Turin 1922

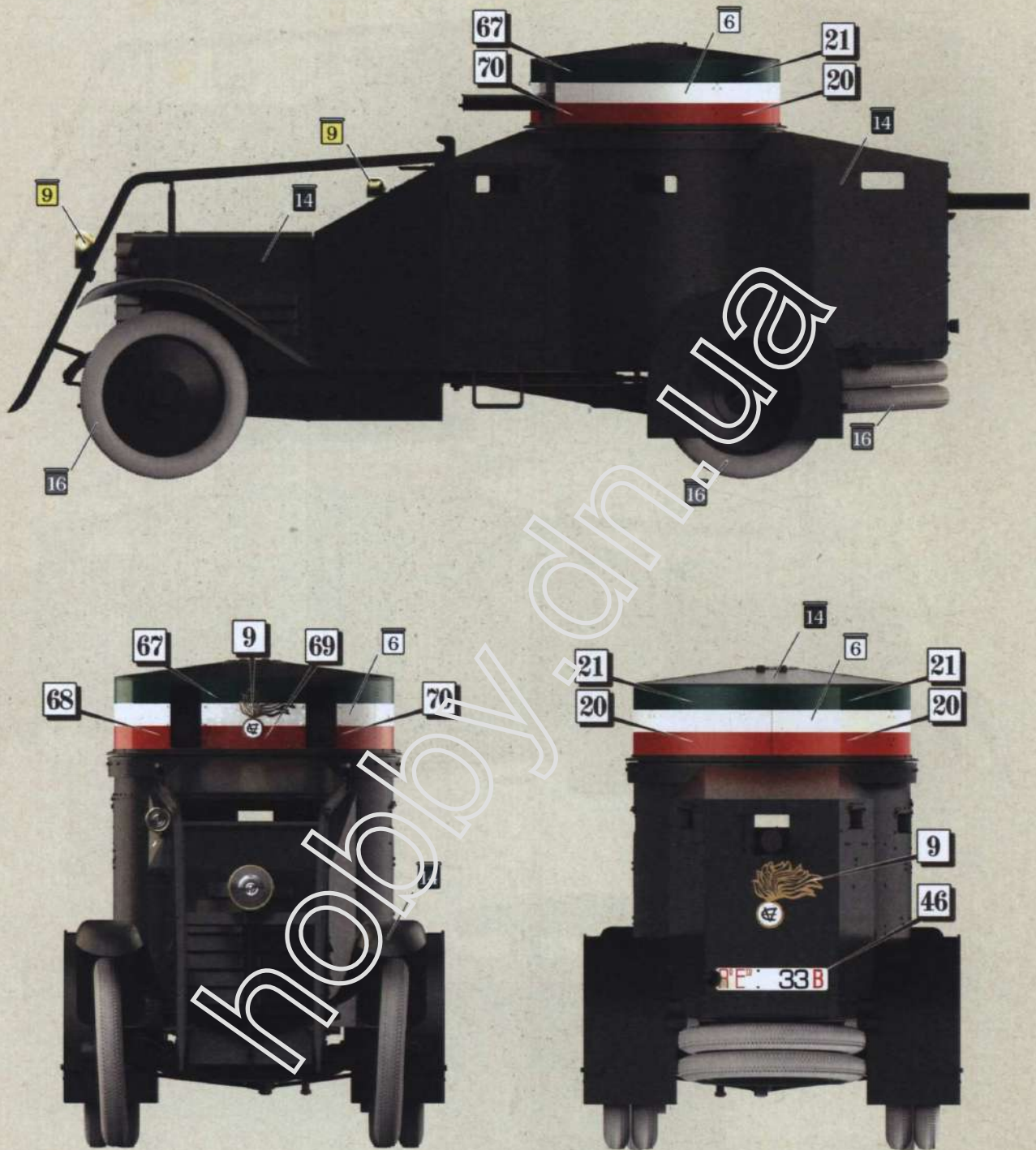
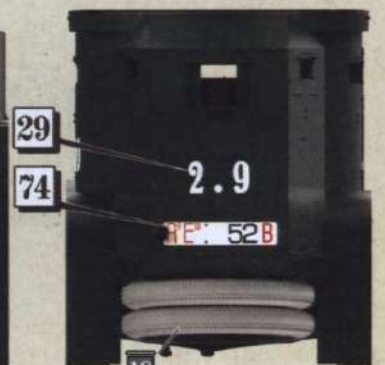
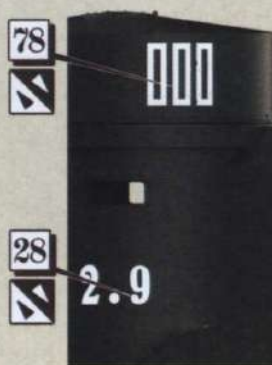
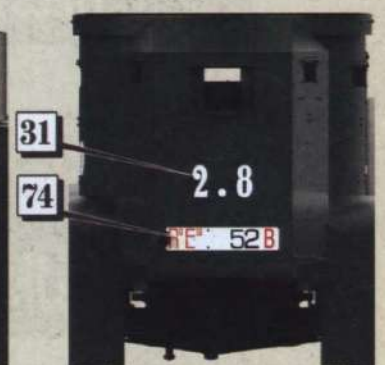
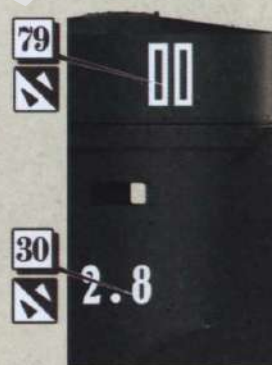
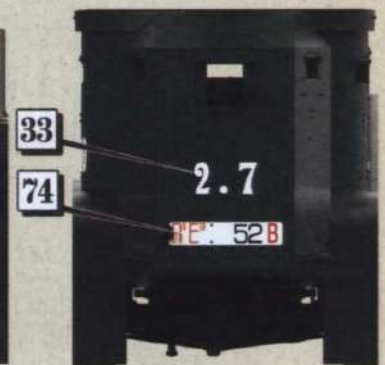

Fig. 19. Nucleo Napoli, Carabinieri Reali (Naples Section, Royal Carabineers), Naples, late 1928



Registration plate numbers are not known for cars 2.9, 2.8, 2.7.
 We are offering number "52 B" to use with these markings



About the paint - dark green, but with a dull look

Fig. 20. 2nd Special Squadron 'S' Giuba river, Ethiopia, April 1936

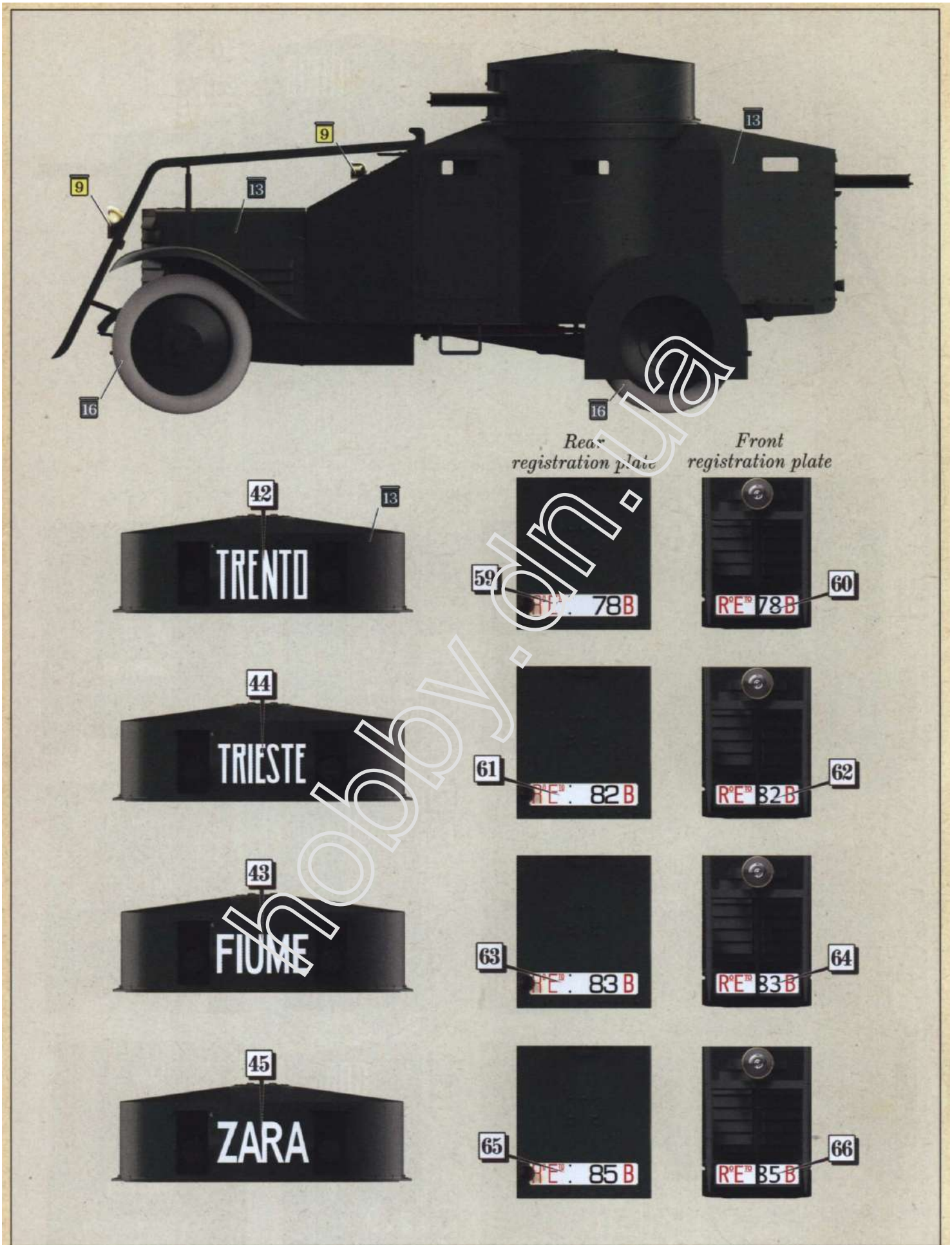
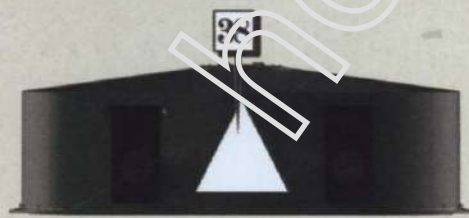
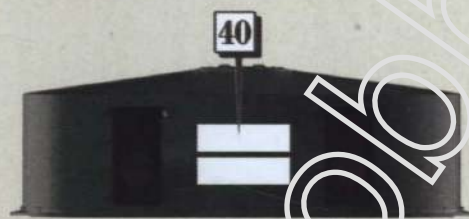
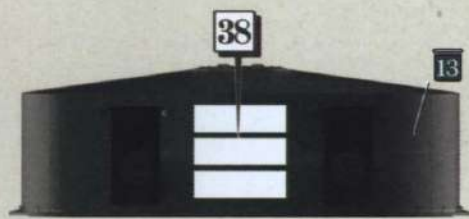
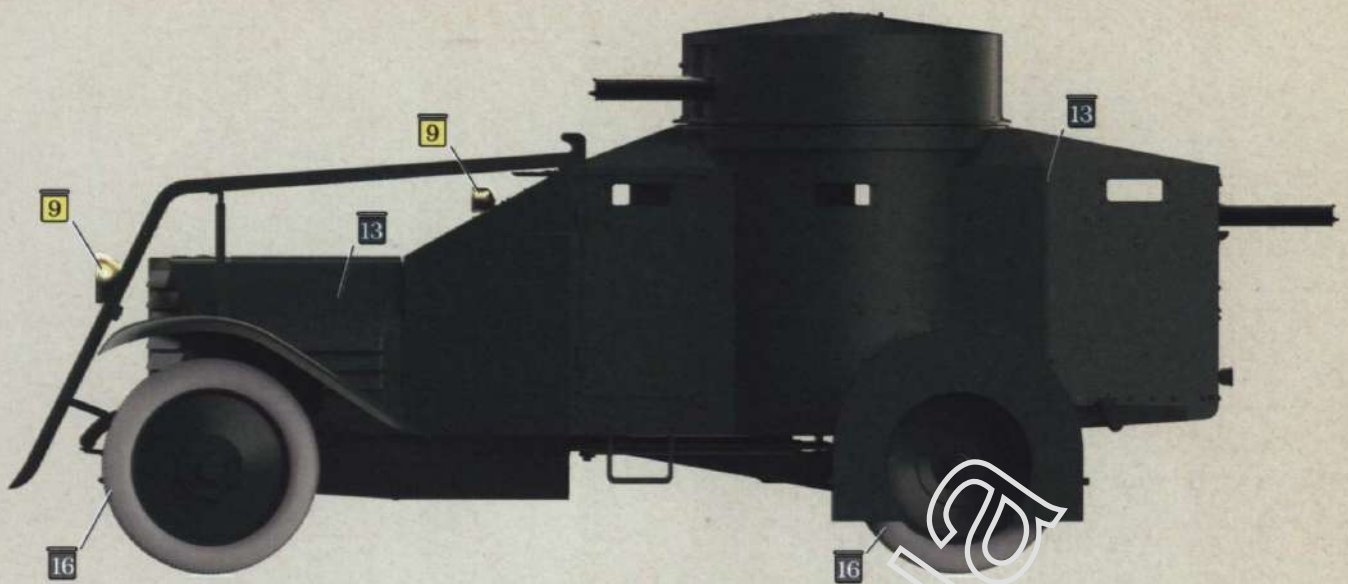

Fig. 21. "San Marco" Marines Regiment – Tien Tsin (China) garrison – 1932 / 1937



Rear registration plate

Front registration plate

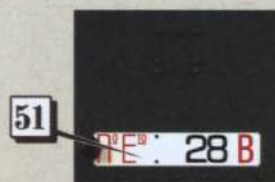

Fig. 22. Gruppo Autoblindo, Reggimento Carri Armati (Armored reconnaissance car Group, Tank Regiment), Codroipo (Italy) 1929 / 1932