

B-10 Export WC / WAN

Instructions

FR

Le prototype, qui vole pour la première fois le 16 février 1932, bénéficie d'importantes innovations techniques : appareil entièrement métallique à train d'atterrissage rétractable, équipé d'une tourelle pivotante, avec soute à bombes interne, il est alors plus rapide que les chasseurs en service. Cet appareil véritablement révolutionnaire marque son époque. Ce bombardier est d'abord livré sous désignation YB-10 pour 14 exemplaires de présérie en novembre 1933, puis la version de production principale, le B-10B, équipée de moteurs plus puissants Wright R-1820-19 de 675 hp est mise en service par l'USAAC (103 exemplaires).

Le B-10 est autorisé à l'export en juillet 1936 avec moteurs Wright. Il est vendu en Chine (9 exemplaires, Wright China ou WC), en Argentine (WAA, Armée et WAN, Marine), à la Turquie (20), au Siam, mais surtout à l'Aviation des Indes Néerlandaises, la MN-KNIL (WH-1, WH-2), en Union Soviétique (un) et au Japon (un). Les appareils chinois sont affectés au 30^{ème} Chungtui (escadrille) du 8^{ème} Tatu (Groupe) et numérotés de 3000 à 3009. Au début de la guerre (juillet 1937), ils sont camouflés en vert olive. Les différentes opérations de l'été 1937 amènent la perte de deux appareils, le passage à l'entraînement à l'automne coûte 3 avions, et la reprise des opérations se solde encore par la perte de deux appareils. Finalement, les deux B-10 survivants sont transférés début 1938 à la 14^{ème} escadrille (Internationale) et renumérotés 1403 et 1404, puis, en avril, passent au 14^{ème} Chungtui où ils conservent leur numéro. Ils bombardent dans la nuit du 19 au 20 mai 1938 le sud du Japon, à partir de terrains situés près de Shanghai. Le 4 juillet 1938, les deux appareils bombardent des positions ennemies à Shanghai, ils disparaissent des inventaires peu après.

La Marine Argentine acquiert en 1937 12 Model 139 WAN, équipés de deux moteurs Wright R-1820-G2. Livrés fin 1937, ils sont répartis entre les Flottilles de Bombardement des Escadres Aériennes n°2 (Puerto Belgrano) et 3 (Rio de la Plata). Ces avions sont utilisés dans des opérations de patrouille maritime, grâce à leur grand rayon d'action, et équipés de grenades anti-sous-marines en externe. Ils ne volent plus en 1948 et sont officiellement retirés du service en 1949. Ils se sont révélés d'une solidité remarquable, le seul 3-B-6 ayant été détruit en service, le 21 mars 1939. Le camouflage des B-10 de la Marine argentine est particulièrement remarquable, appareil gris clair avec dessus des ailes jaune, ancrés sur et sous les ailes.

Spécifications (WAN):
bombardier bimoteur monoplane à train rentrant, de construction métallique, 4 membres d'équipage. Moteurs : deux Wright Cyclone R-1820-G2 de 850 hp à 2 100 t/mn. Envergure 21,49 m, longueur 13,63 m, surface alaire 63 m². Vitesse maximum 306 km/h au niveau de la mer. Altitude maximale de travail, 5 182 m. Armement : 1 029 kg de bombes, 3 mitrailleuses.

EN

The prototype first flew on February 16, 1932. The B-10 combined several innovations including an all-metal airframe, fully cowled engines, retractable landing gear, enclosed gun-turret, and internal bomb-bay, which made it faster than fighters then in service. Although built in relatively small numbers, the B-10 was revolutionary, and was the USAAC's first all-metal monoplane bomber. In January 1933, 14 pre-production YB-10s were ordered, then USAAC received 103 of the main production version, the B-10B, equipped with more powerful 675 hp Wright Cyclone R-1820-19 engines.

The B-10 was cleared for export in July 1936 as the Model 139 with Wright engines. Customers included China (nine 139 WC), Argentina (22 139 WAA and 12 139 WAN), Turkey (20 139 WT), Siam (six 139 WSM), and the Dutch East Indies which was the biggest user (13 139 WH-1, 26 139 WH-2, and WH-3, largely modified), the Soviet Union (one 139 WR) and Japan (one 139 WJ). The Chinese aircraft were assigned to the 30th Chungtui (squadron) of the 8th Tatu (Group) and coded from 3000 to 3009. At the beginning of the war with Japan in July 1937, the Martin 139s were camouflaged in olive green. The various operations in the summer of 1937 led to the losses of two aircraft, the training in Fall 37 costed 3 aircraft, and new operations resulted in the losses of two additional aircraft. Finally, the two surviving Martins were transferred in early 1938 to the 14th (International) squadron and renumbered 1403 and 1404. When the Sqn was disbanded in April, the aircraft were transferred to the 14th Chungtui, keeping their codes. During the night of May 19-20, 1938, they bombed southern Japan in a daring raid. On July 4, 1938, the two Martins bombed enemy positions in Shanghai, and were written off inventory shortly afterwards.

In 1937, the Argentine Navy bought 12 Martin 139 WANs, equipped with two Wright R-1820-G2 engines. The aircraft were delivered at the end of 1937, and were assigned to the Bombing Squadrons of Escuadra Aérea n°2 (Puerto Belgrano) and n°3 (Rio de la Plata). They were used in maritime patrol operations, thanks to their long range, and carried anti-submarine depth-charges externally. They were officially withdrawn from service in 1949. They proved to be remarkably resilient in the Naval service, only aircraft number 3-B-6 (MSN 726) being destroyed in service on March 21, 1939. The camouflage schemes of the Argentine Navy B-10s were quite eye-catching with yellow wings and light grey fuselage with anchor insignias on both wing surfaces.

Specifications (139 WAN):
twin-engine monoplane bomber with retractable landing gear, metal construction, 4 crew members. Engines: two Wright Cyclone R-1820-G2 of 850 hp. Wingspan 21.49 m, length 13.63 m, wing area 63 m². Maximum speed 306 km/h at sea level. Maximum altitude, 5,182 m. Armament: 1,029 kg of bombs, 3 Colt MG-40 cal. .30" machine guns.

Many thanks to / Remerciements à Michel Ledet / Patrick Laureau / Mark Tutton

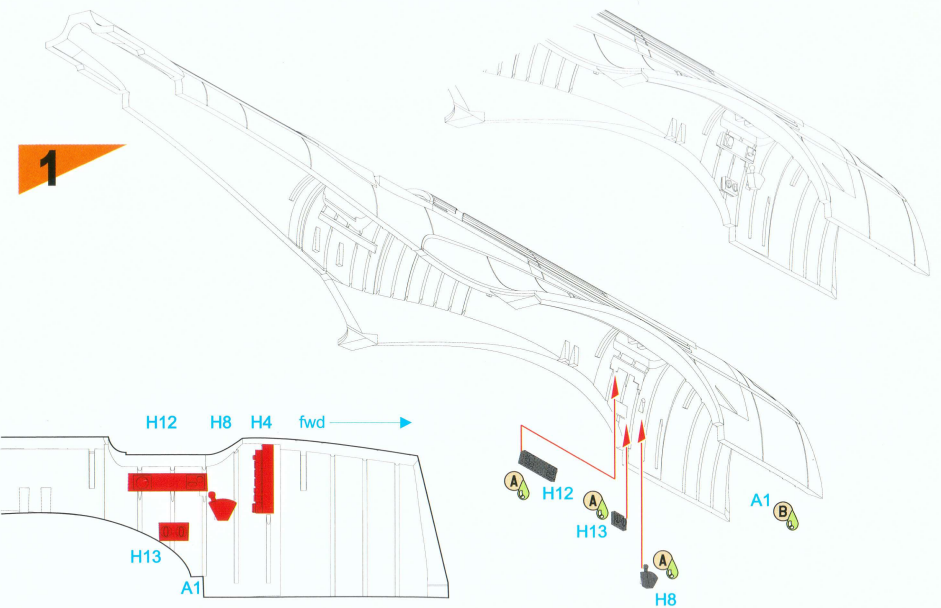

Note on the interior colours

- Cockpits and turret area, undercarriage bays, legs, engine cowlings:
- 1) Pre-war B-10/12 airframes - Aluminium Lacquer
- 2) export Model 139s - might already have been in Zinc Chromate Green.

The exceptions were the instrument panels and a few other items which were either in Black, Bronze Green or Zinc Chromate Green as indicated throughout the build steps.

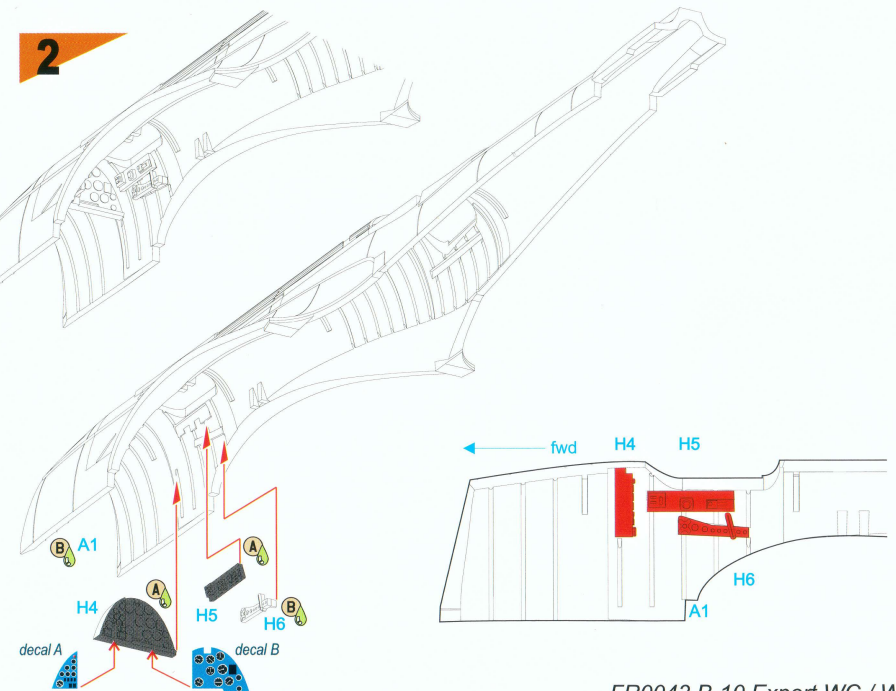

4

3

STEP 2

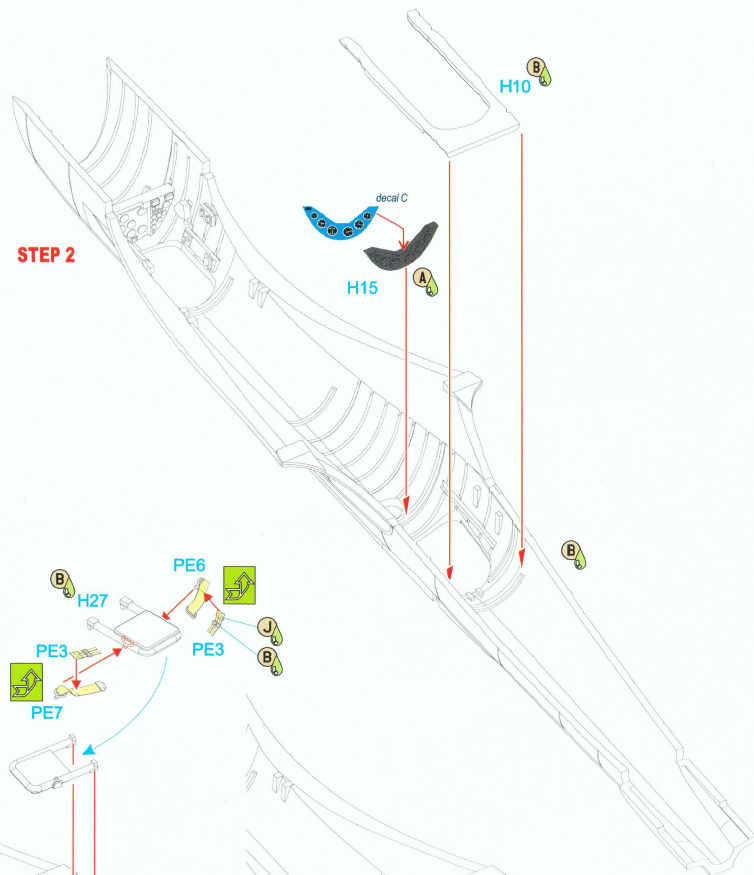

4

STEP 3

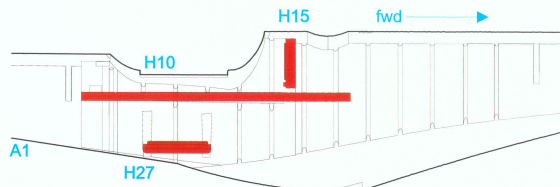
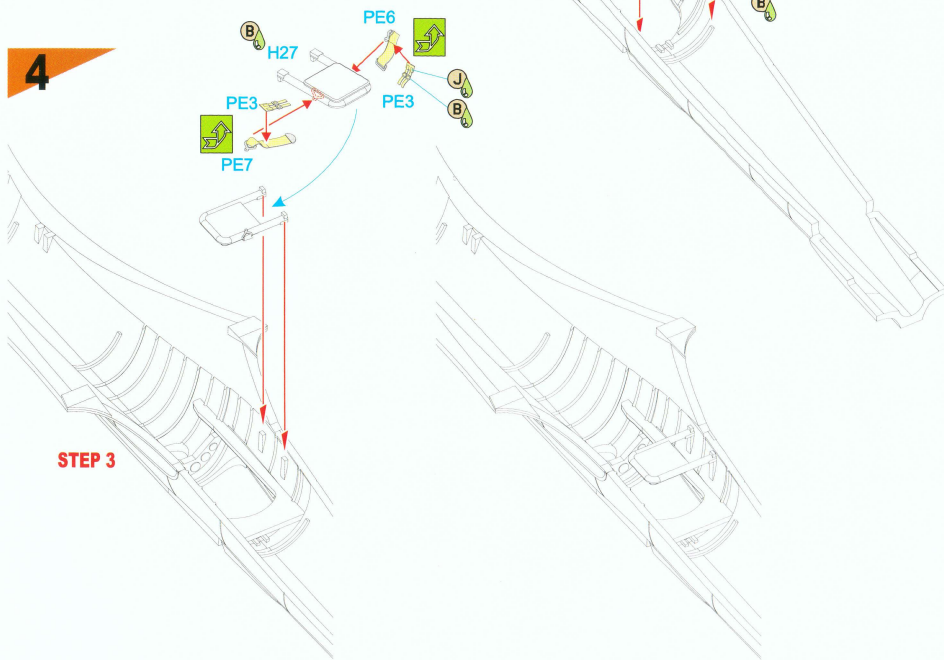

FR0043 B-10 Export WC / WAN ⑤

5

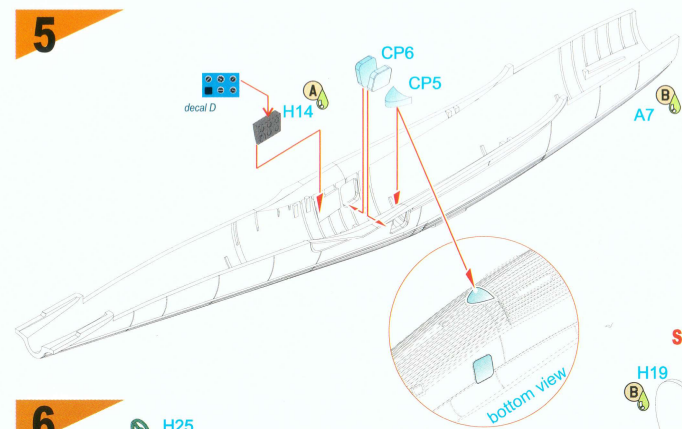

6

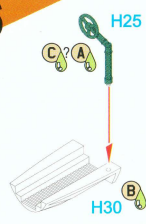

7

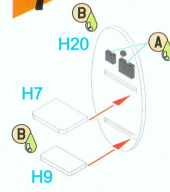

8

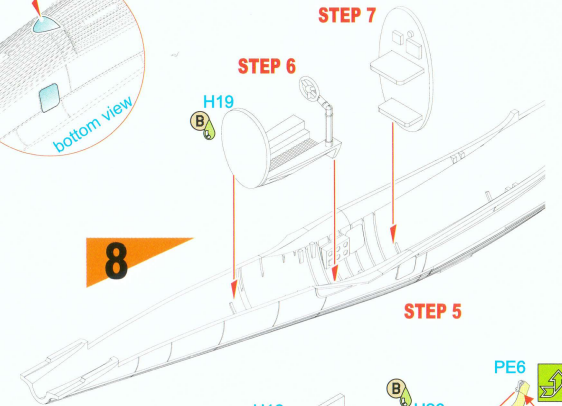

9

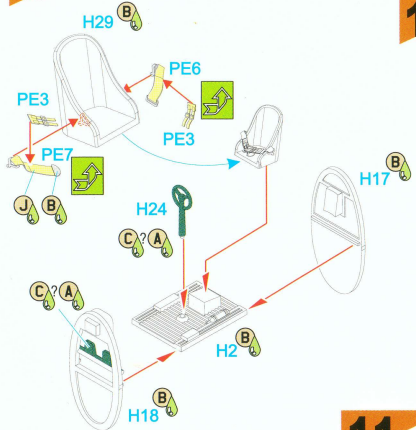

10

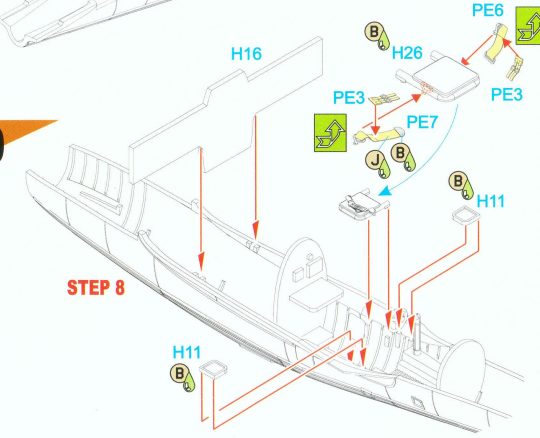

11

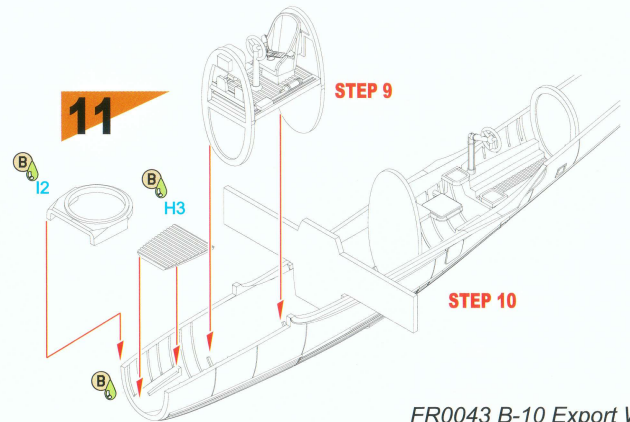

⑥

FR0043 B-10 Export WC / WAN

12

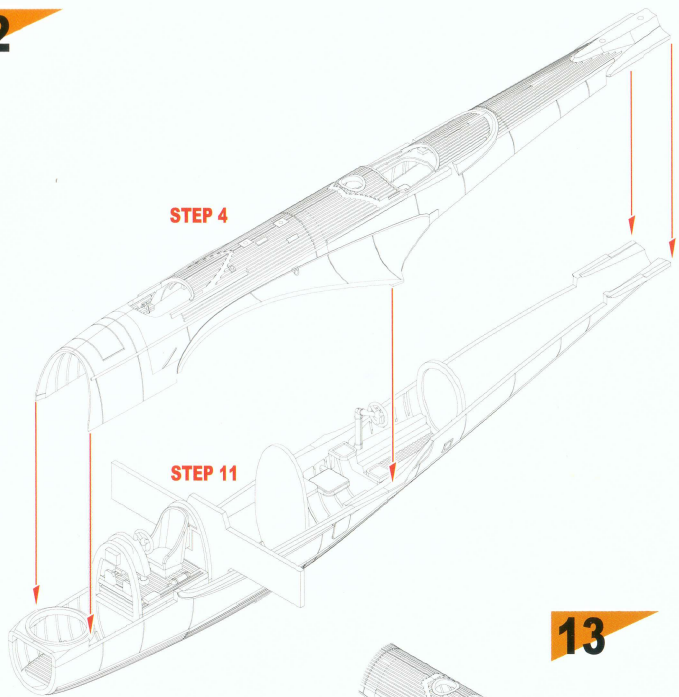

13

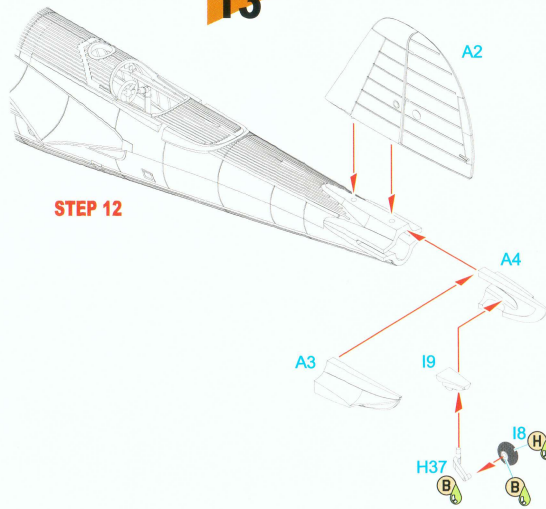

14

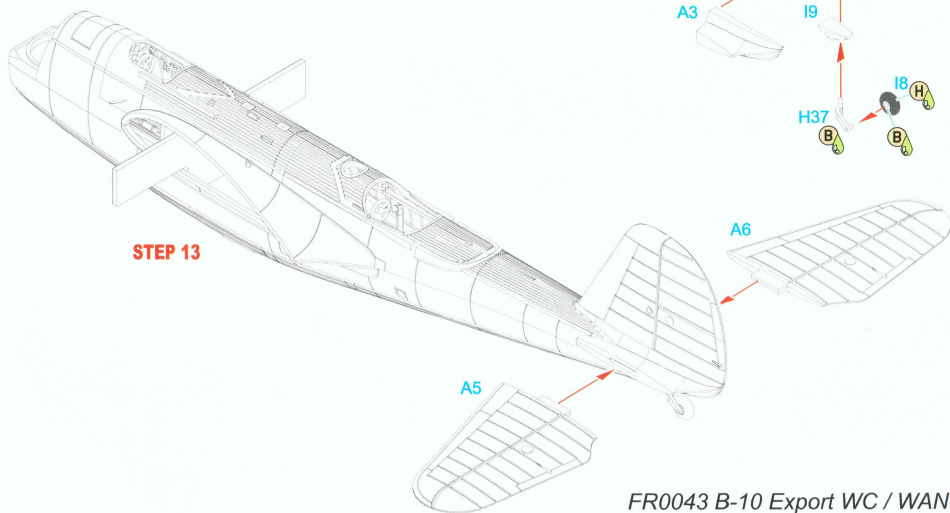

FR0043 B-10 Export WC / WAN 7

15

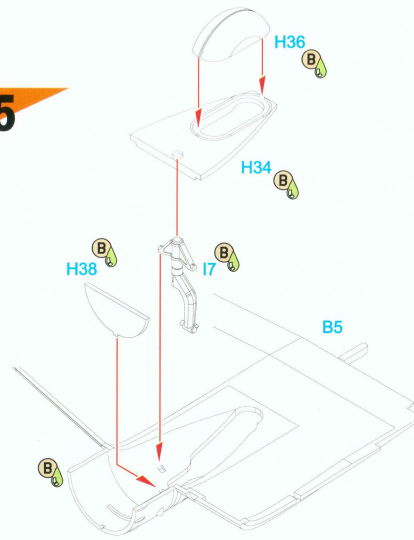

16

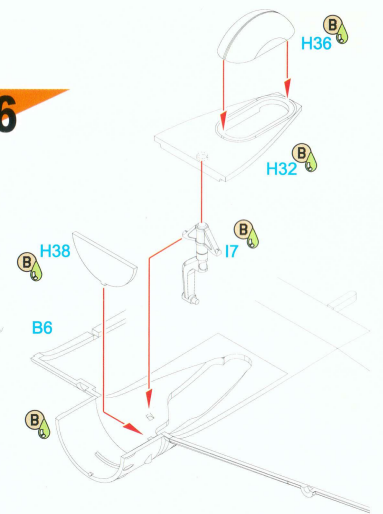

17

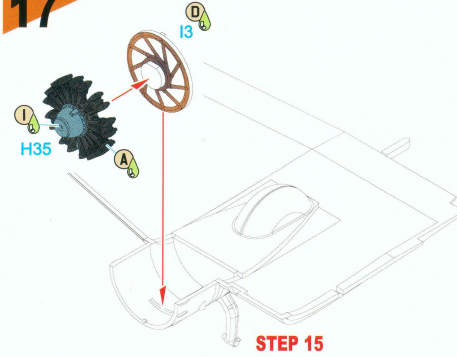

18



19

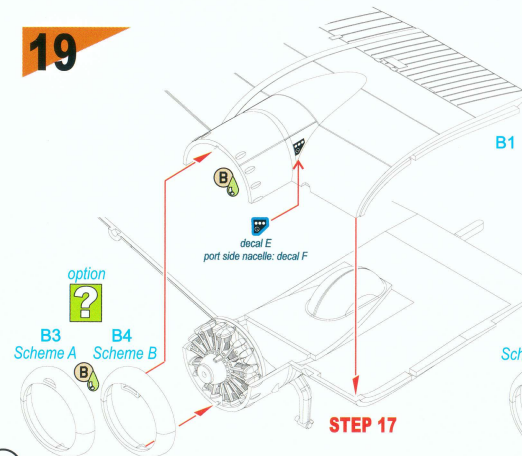

20

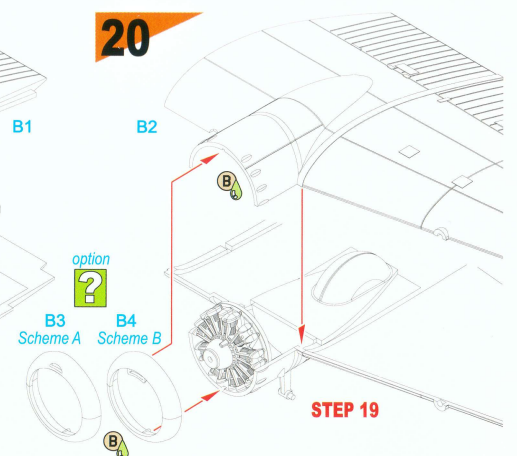

8 FR0043 B-10 Export WC / WAN

21

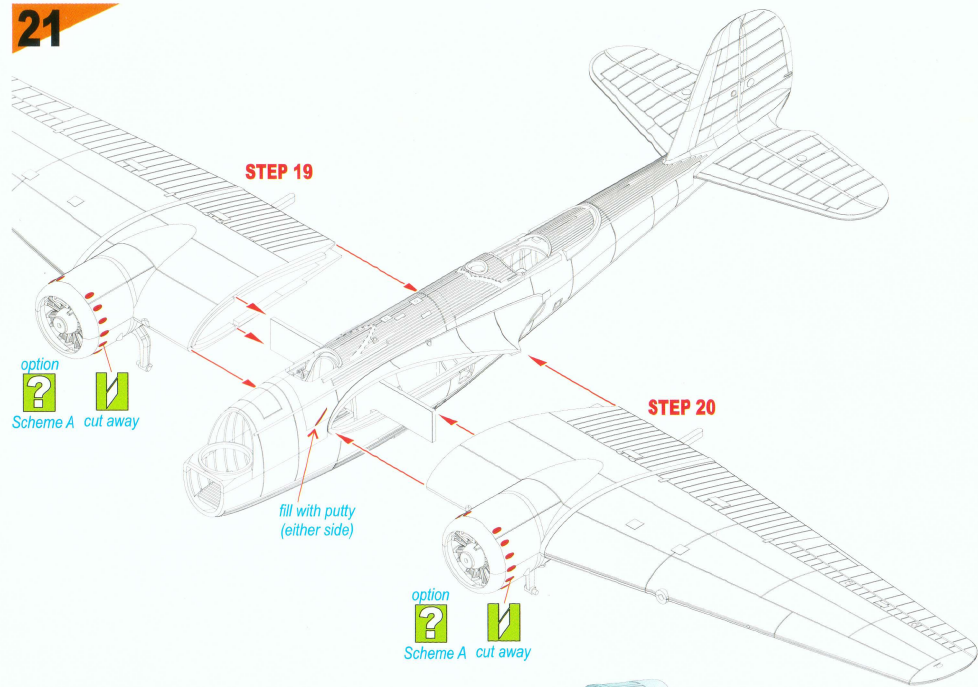

22

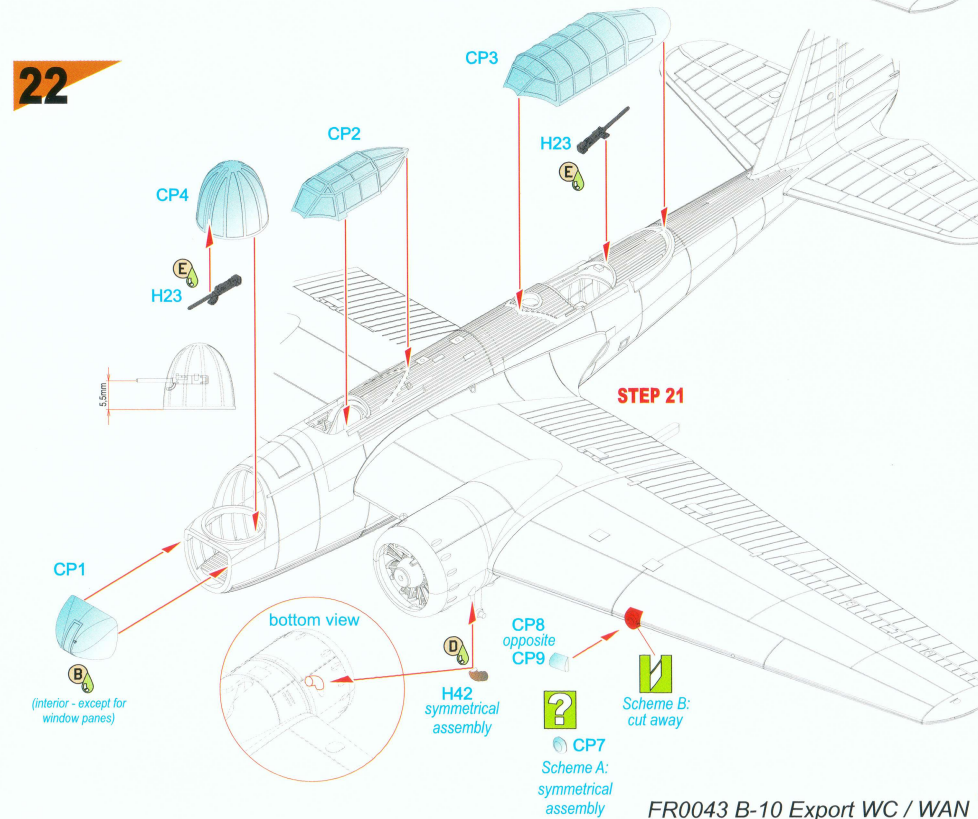

23

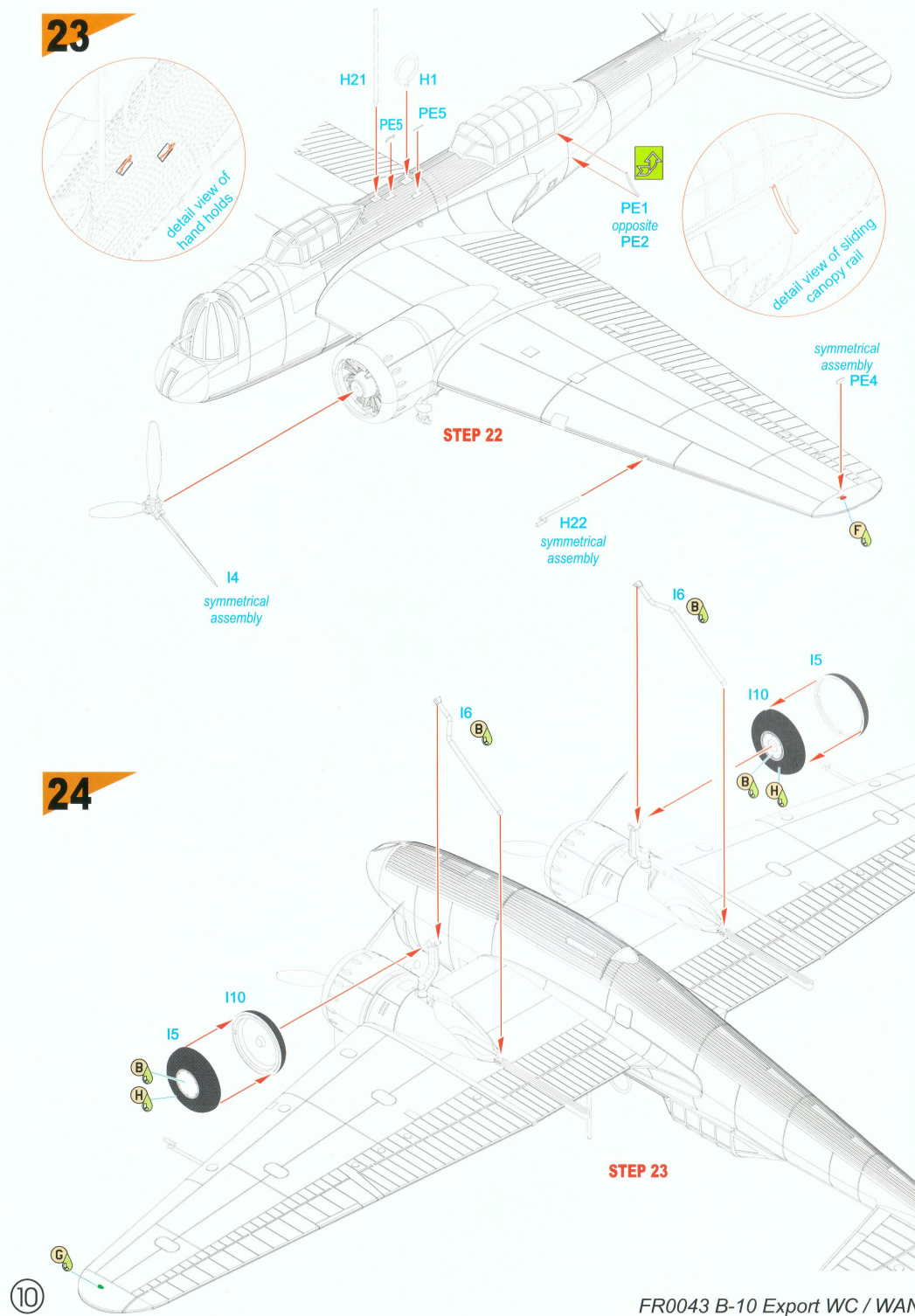

PARTS LIST

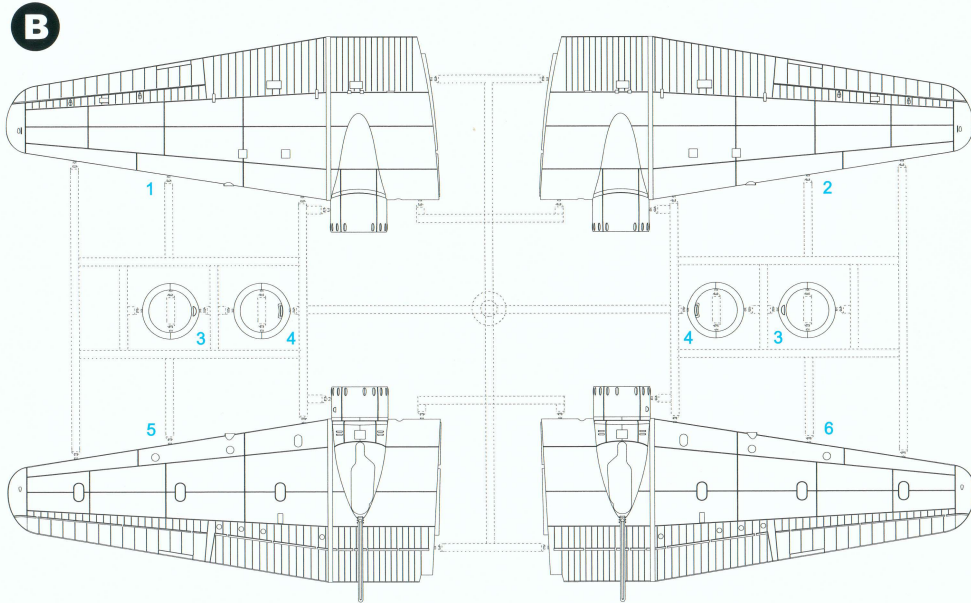
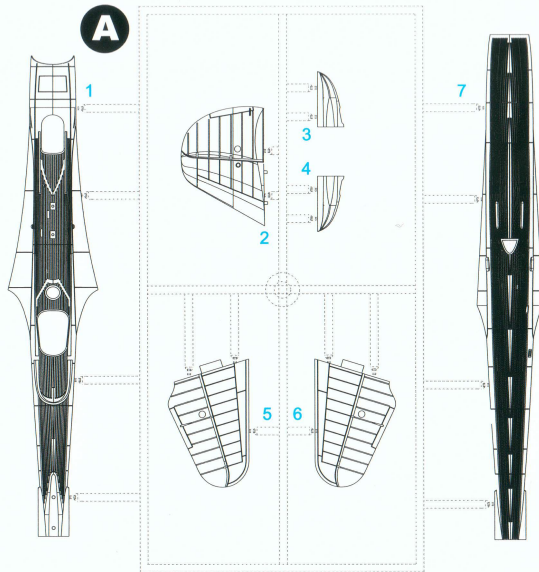

SYMBOLS

? MOŽNOST VOLBY
OPTIONAL
NACH BELIEBEN
OPTION

POUŽÍŤ KYANOAKRYLÁTOVÉ LEPIDLO
INSTANT CYANOACRYLATE GLUE
ZYANOAKRYLATKLEBER
COLLE CYANOACRYLATE

OHNOUT
BIEG
BIEGEN
COURBER

ZHOŤOVIT NOVÉ
SCRATCH BUILD
FERTIGSTELLEN
ACHEVER

REZAT/VRTAT
CUT OFF/DRILL
ENTFERNEN
DETACHER

GSI
colours code
NATRÍT
COLOUR
FARBEN
PEINDRE

PARTS LIST

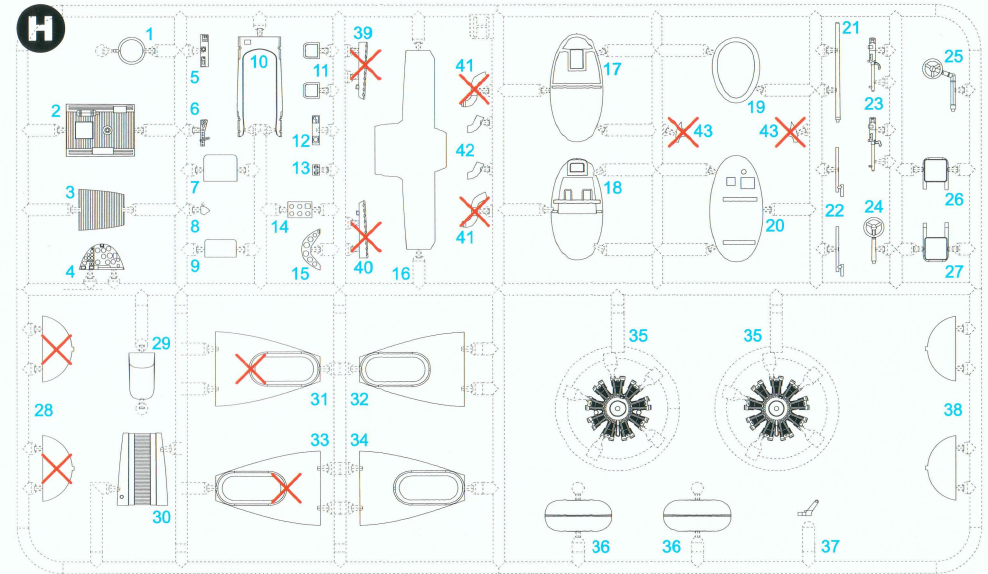

Clear Parts (CP)

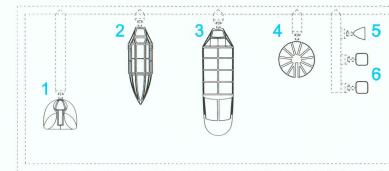

7 8

7 9

X = parts not to be used

Barvy GUNZE / GUNZE Colour No.

A	Noir / Black	H12/C33
B	Aluminium / Aluminium	H/C8
C	Vert Bronze / Bronze Green	H/C340
D	Métal Carbonisé / Burnt Metal	H76/C61
E	Métal Noir / Gun Metal	H28/C78
F	Rouge Clair / Clear Red	H90/C47
G	Vert Clair / Clear Green	H94/C138
H	Pneu Noir / Tire Black	H77/C137
I	Gris / Aircraft Gray	H57/C73
J	Toile / Sail	H85/C45

I

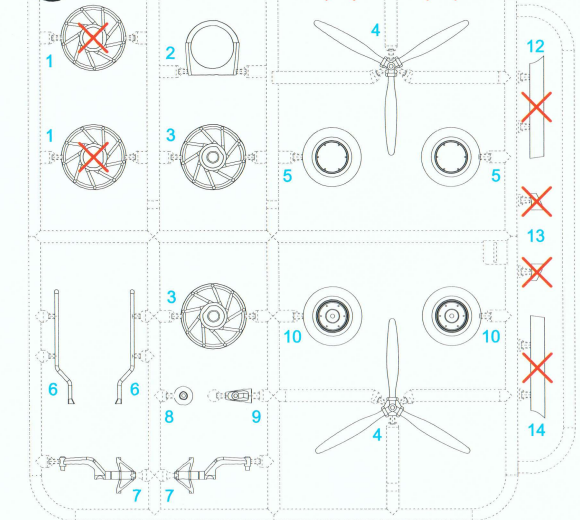
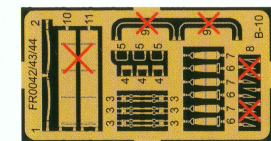

Photo-Etched Parts (PE)



Model 139 WAA, 2-B-3, Escuadrilla de Bombardeo, Escuadra Aérea n°2, Marine Argentine, Puerto Belgrano. Appareil du commandant de flottille.

Model 139 WAA, 2-B-3, Escuadrilla de Bombardeo, Escuadra Aérea n°2, Argentine Navy, Puerto Belgrano. Aircraft of the Flotilla leader.

Model 139 WC, 1403, 14 ème escadrille internationale, janvier à mars, puis 14 ème Chungtui, avril à juillet 1938, Armée de l'Air chinoise, Hankéou.

Model 139 WC, 1403, 14 th Volunteer Sqn from January to March, then 14 th Chungtui, April to July, 1938, Chinese Air Force, Hankow.

Scheme B



FR0043 B-10 Export WC / WAN

Scheme A

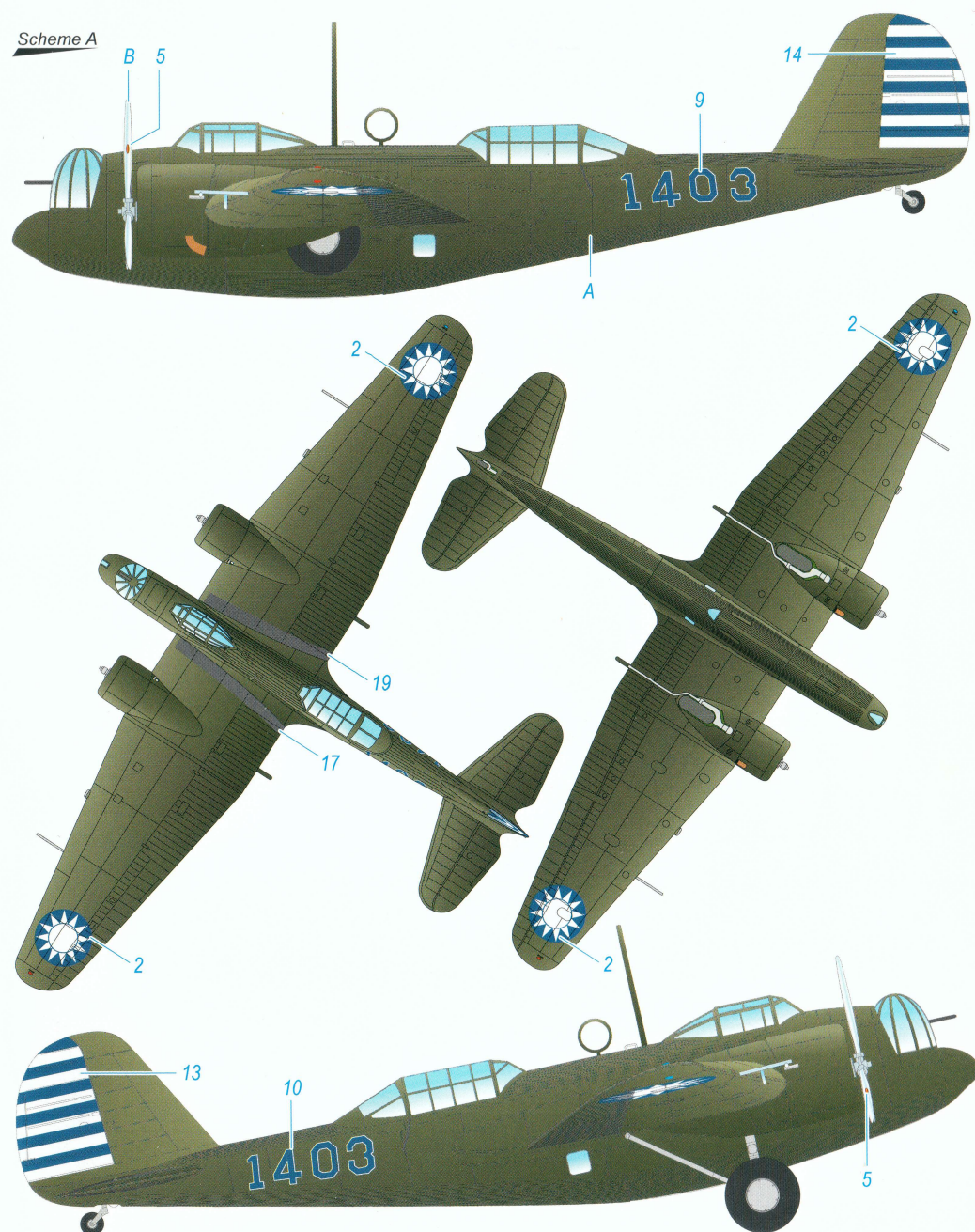

FR0043 B-10 Export WC / WAN