

This view shows main undercarriage in 'retracted' position.

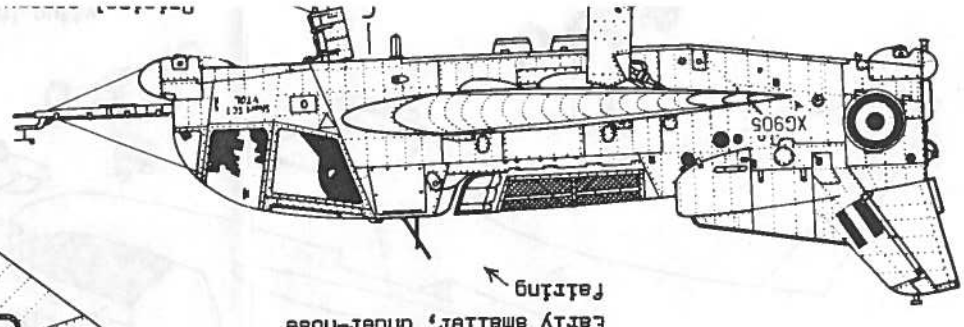

Early smaller, under-nose fairing

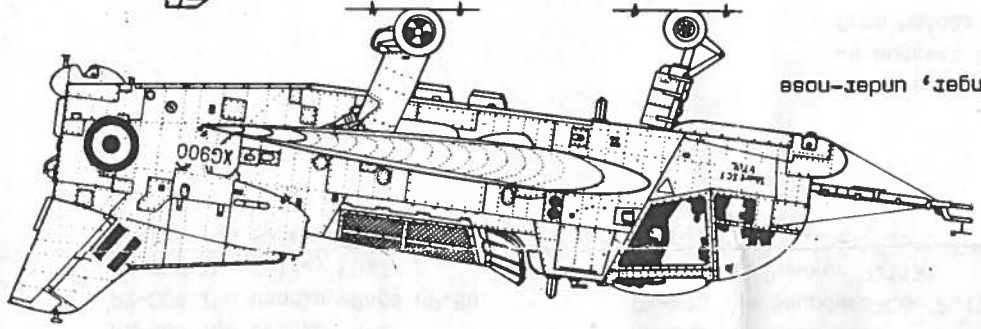

Later longer, under-nose fairing

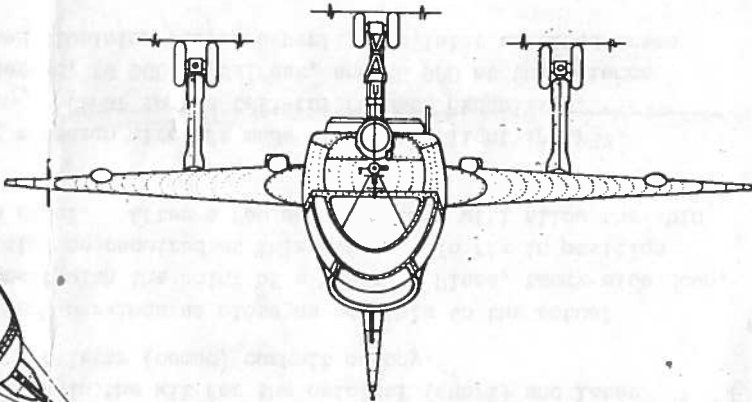
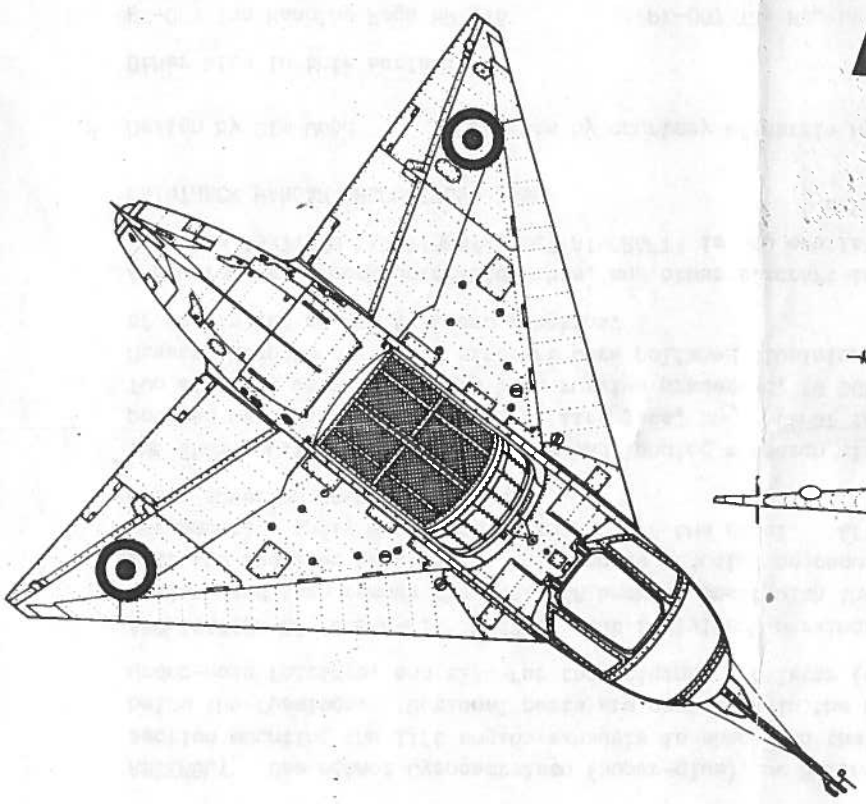

the Short SC1

PX-013

PREPARATION Carefully eliminate any mould lines on the resin castings with a knife and fine grade wet-and-dry paper.

ASSEMBLY Use either Cyanoacrylate (Super-glue), or 5-minute 2-part Epoxy adhesive. Note that the section mounting the lift engine exhausts is shaped so that it can only fit one way into the recess below the fuselage. Optional parts are contained in the kit for the original (short) and later under-nose fairings, and also for the original and later (domed) cockpit canopy.

APPLICATION OF 'CLEAR-FIX' DECALS Cut individual markings as close as possible to the actual design, and then remove the peel-off backing sheet with the point of a knife. Place, tacky side down, into the required position. This can be adjusted as required at this stage. To fix in position permanently, apply water to the surface of the decal. After a few seconds, this will allow the thin paper covering to be wiped away.

THE SHORT SC.1 Vertical take-off and landing research aircraft made its first flight in 1957,

powered by four Rolls-Royce RB 108 lift jets, and another in the tail for forward propulsion. Two aircraft were built, and both survive preserved, XG 905 at Belfast, and XG 900 at the Science Museum, Wroughton. Both aircraft were polished aluminium silver overall, and later acquired areas of dayglo red on the tail and wingtips.

A comprehensive book describing this, and other aircraft in the 'Project-X' series of model kits, entitled 'BRITISH EXPERIMENTAL JET AIRCRAFT' is now available from Maintrack Models, price £32.50.

MAINTRACK HANGAR PRODUCTIONS 1990

Design by Jim Wood Drawings by courtesy of Barrie Hygate

Other kits in this series:

PX-001 The Handley-Page HP 115

PX-002 The Bell X-2

PX-003 The Douglas X-3

PX-004 The Handley-Page HP.88

PX-005 The Fairey FD.1

PX-006 The Supermarine 510

PX-007 The Hawker P.1052

PX-008 The Hawker P.1081

PX-009 The Avro 707C

PX-010 The Saunders-Roe P.177

PX-011 The Hawker P.1121

PX-012 The BAC.221

For a really authentic aluminium finish we suggest SMC 'SPRAY-METAL'. Available from Maintrack Models.

Take care when trimming vac-form canopy. Attach to model using P.V.A. glue - do NOT use Super-glue.

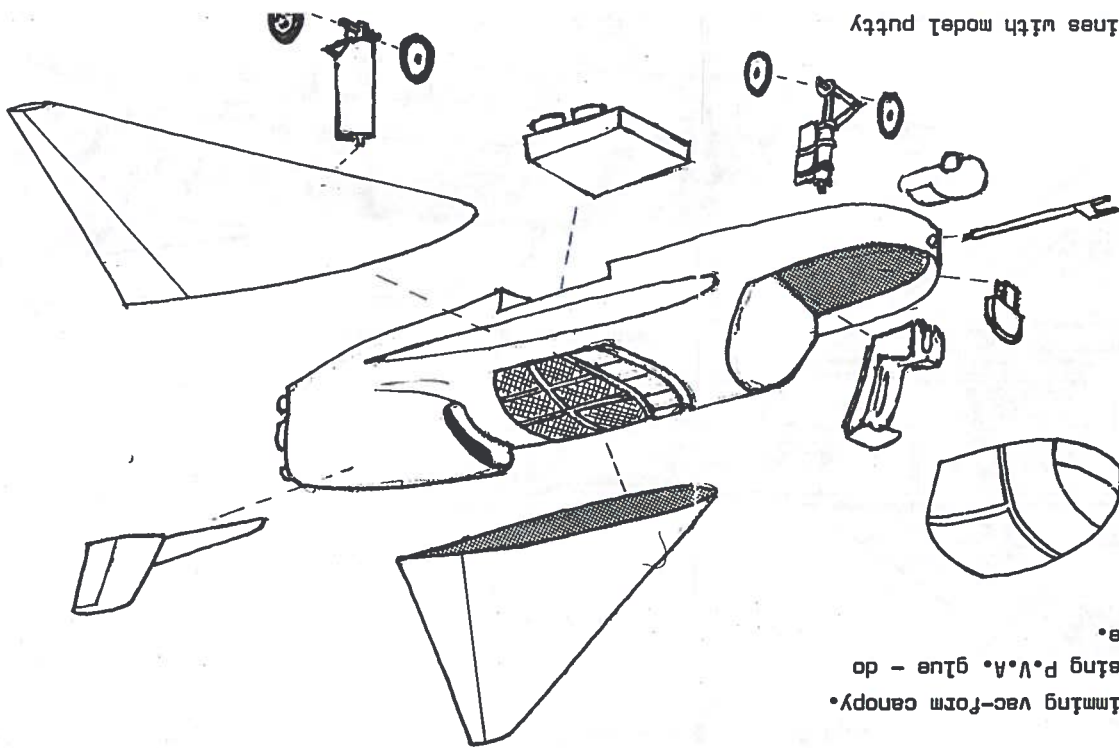

Fill in any joint lines with model putty