

How to put your model together / Méthode d'assemblage de votre modèle / Wie stellt man



Cement parts together.
Coller les pièces ensemble.
Teile zusammenkleben.
Cementeer de delen samen.
Limma ihop delarna.
Cementare le parti l'una con l'altra.
Osat liimataan yhteen.



Do not cement together.
Ne pas coller ensemble.
Nicht zusammenkleben.
Cementeer niet samen.
Limma inte ihop delarna.
Non cementare le parti.
Osia ei liimata yhteen.



Shape with hot knife.
Former au canif chaud.
Mit einem heissen Messer formen.
Vorm met een heet mes.
Forma med varm kniv.
Modellare con la lama di un coltello, riscaldata.
Muovattaa kuumalla veitsellä.



Choice of parts provided.
Choix de pièces fournies.
Mittellieferte Auswahl an Teilen.
Keuze van beschikbare onderdelen.
Dessa delar medföljer för valfri användning.
Particolari a scelta.
Osien kay to valinnanvaraista.



Paint parts before using.
Peindre les pièces avant l'emploi.
Die Teile sollen vor Benutzung bemalt werden.
De onderdelen voor het gebruik schilderen.
Måla delarna före användningen.
Verniciare le parti prima di montarle.
Maalattaa osat ennen kokoamista.



Cut with sharp knife.
Couper avec un couteau tranchant.
Mit einem scharfen messe schneiden.
Snijd met een scherp mes.
Skär med en skarp kniv.
Tagliare con un coltello affilato.
Leikatkaa terävällä veitsellä.



Insert small weight.
Introduire le petit contrepoids.
Das kleine Gewicht soll eingesteckt werden.
Een klein gewichtje invoegen.
Stick in en liten tyngd.
Introdurre il piccolo peso.
Lisä tkää pieni paino.

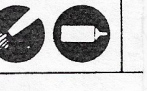
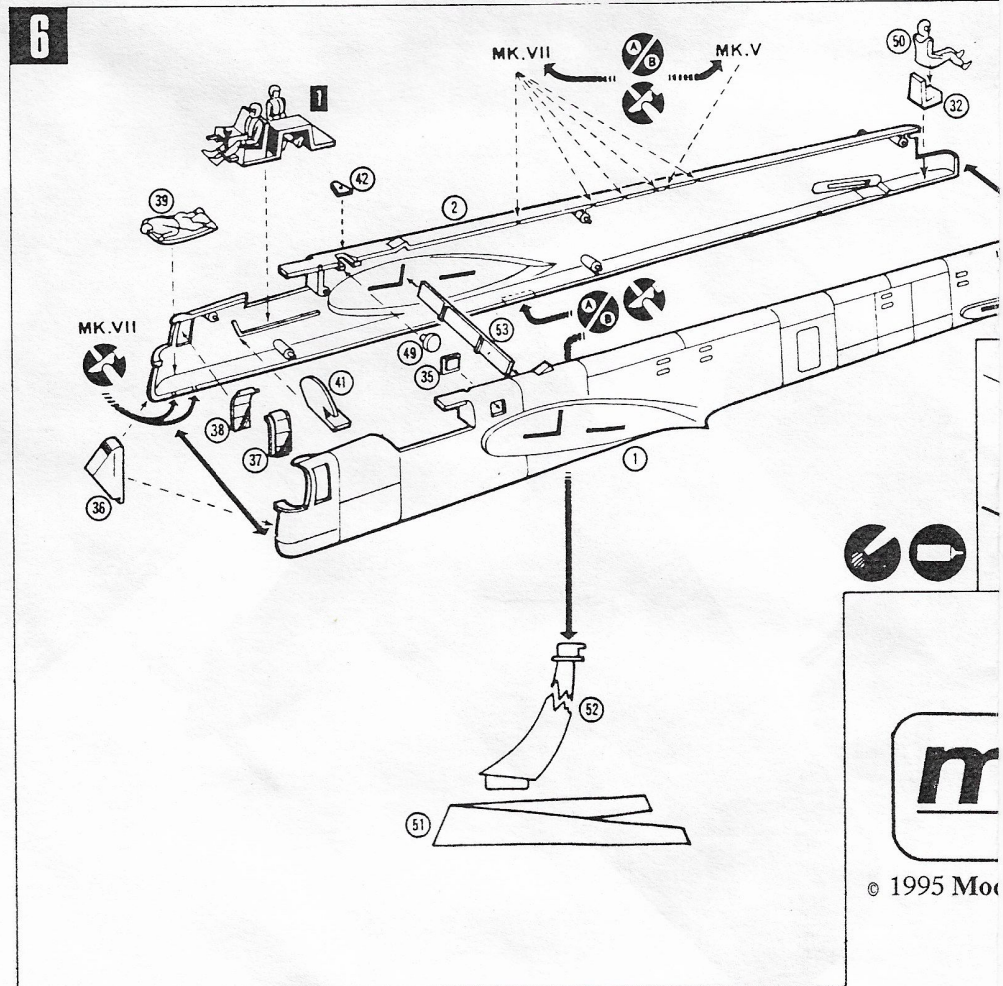
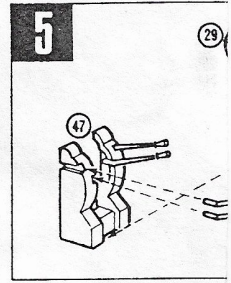
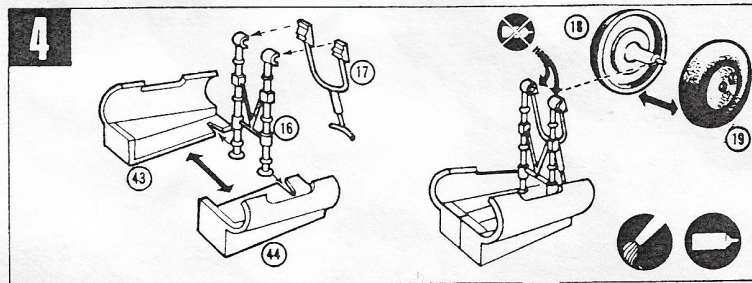
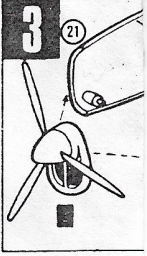
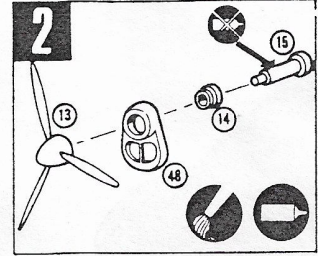
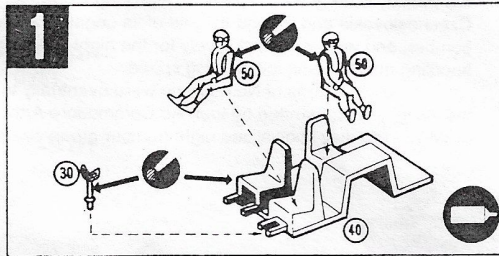

Ihr modell zusammen/Come montare il modello /Hoe zet ik mijn model in elkaar/Hur man sätter ihop modellen/Kootkaa mallinne näin.

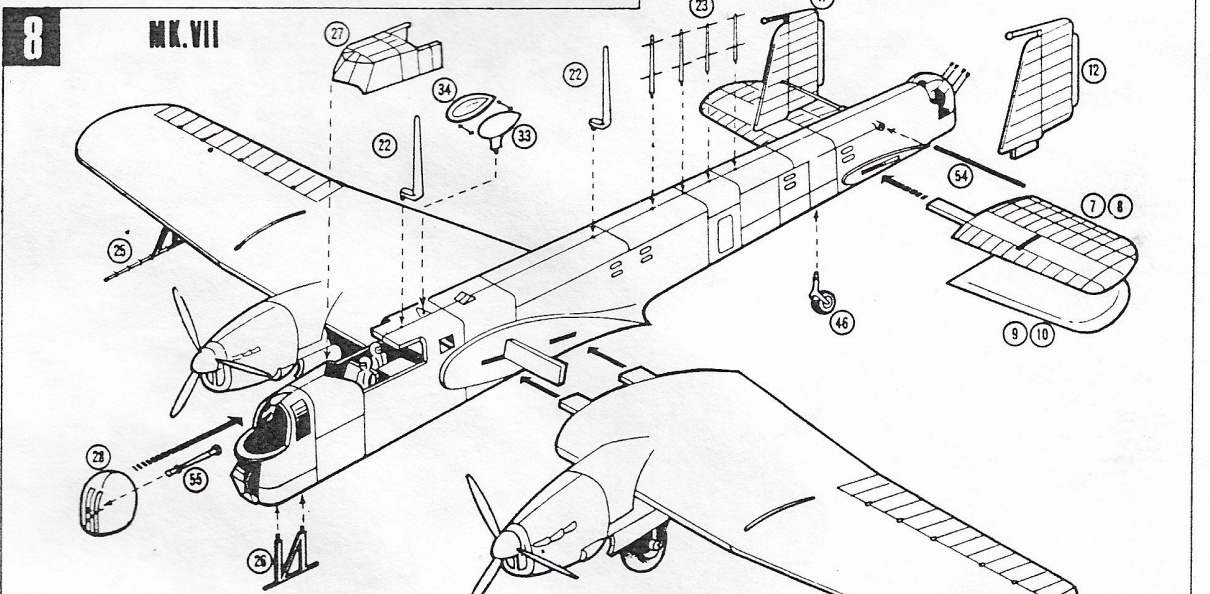
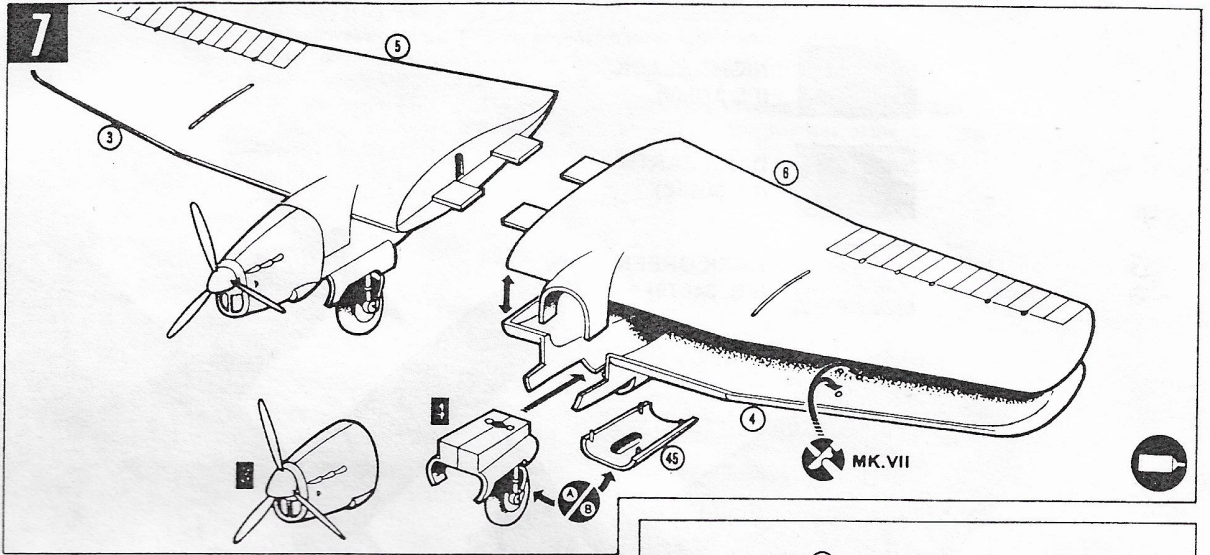
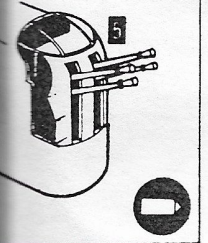
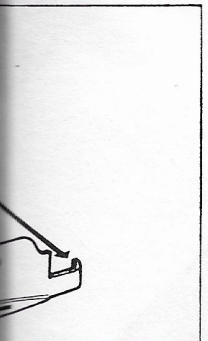
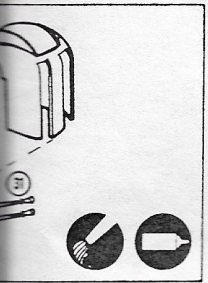
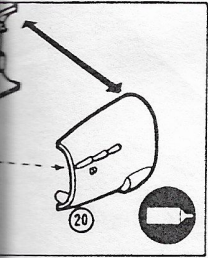

Modelcraft
A division of Sealand Imports Ltd.

Modelcraft, Burnaby, B.C. V5G 4J9 Printed in Canada

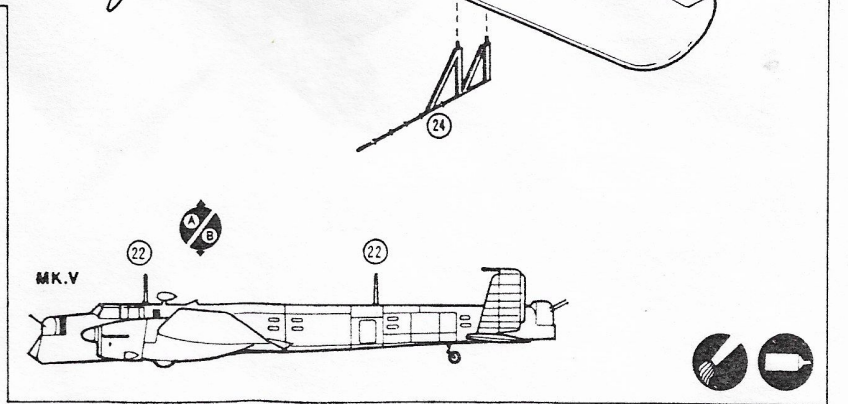

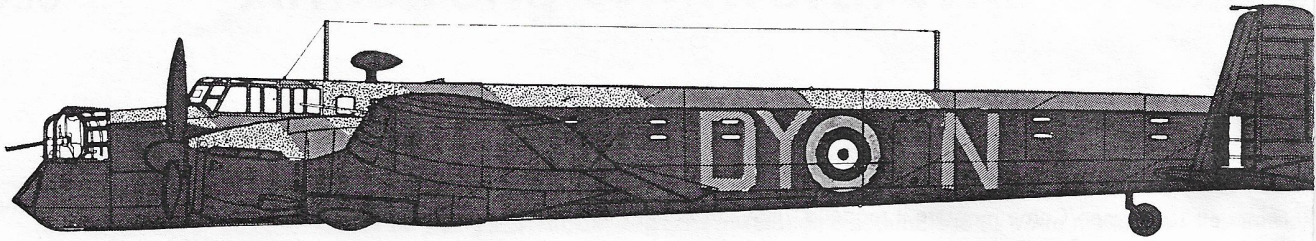

NIGHT BLACK
(FS 37038)

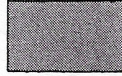

DARK EARTH
(FS 30118)

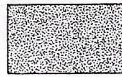

DARK GREEN
(FS 34079)



Armstrong Whitworth Whitley B.Mk.V

The Armstrong Whitworth Whitley was built to RAF Specification B.3/34 issued in July 1934 for a monoplane twin engine heavy bomber. It was ordered into production in June, 1935, long before the prototype, K4586, first flew on 17 March, 1936.

The B.Mk.V was the main production version, and was a development of the B.Mk.IV, both having Rolls Royce Merlin engines in place of the Armstrong Siddeley Tiger radials of the B.Mk.I, II and III. Aerodynamic improvements were incorporated to improve handling, and, as with the B.Mk.IV, power operated turrets were installed in the nose and tail positions. With provision for more fuel and the addition of deicing boots the Whitley B.Mk.V was capable of attacking targets as far away as Austria, Czechoslovakia and Poland. In spite of its ungainly appearance, it was an effective bomber, and was used exclusively for the night bombing role because of its good handling qualities and low landing speed.

The squadrons of No.4 Group were eventually to be completely equipped with the Whitley. Commanded by then Air Commodore Arthur Harris, it was, at the beginning of WWII, the only specialized night bomber group operational in the Royal Air Force.

