

FOKKER T-V

The T - V was the only modern medium bomber in Dutch service at the beginning of WW II. Designed, flown and manufactured in 1938, it was a thoroughly modern aircraft with good flight characteristics, range and speed.

Originally, 16 aircraft were ordered but only 9 were operational in May of 1940 to face the Nazi onslaught. But these few machines acquitted themselves quite well. They bombed and strafed the ground troops advancing on Rotterdam, they attacked the JU-52 formations landing troops on the beaches of the Meuse river and made other sorties of varying success during their brief, but tenacious, three days of operational usage.

But their most important contribution to the brief campaign was their use as a sort of "heavy fighter". The T - V was armed with a 20mm cannon on a flexible mounting in the nose. Operated by the bombardier, its accuracy was to bring about the first two aerial victories for the Dutch airforce.

Although soon outnumbered, outgunned and overrun, these few aircraft proved to be worthy opponents in the hands of their very capable Dutch pilots.

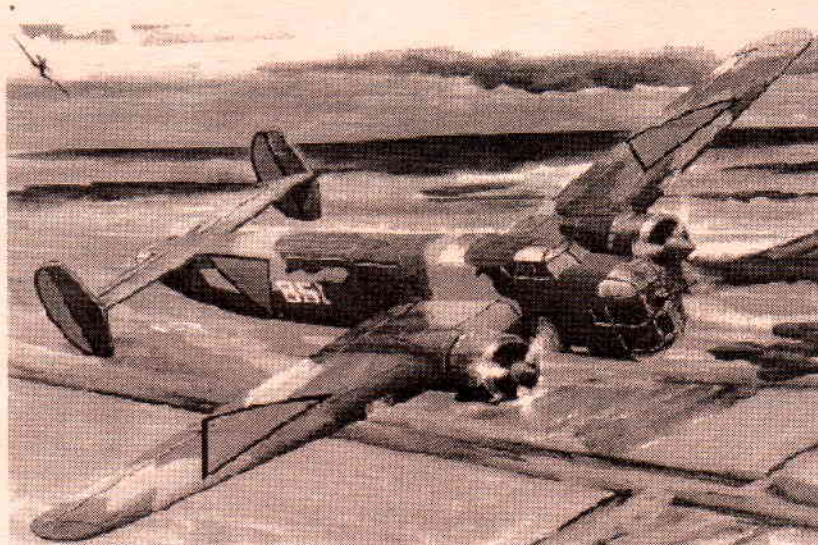

But their most important contribution to the brief campaign was their use as a sort of "heavy fighter". The T - V was armed with a 20mm cannon on a flexible mounting in the nose. Operated by the bombardier, its accuracy was to bring about the first two aerial victories for the Dutch airforce.

SOME IMPORTANT CONSTRUCTION NOTES

Become thoroughly familiar with all these parts and these plans before proceeding. Always... always... **ALWAYS**... trial check the fit of all parts before assembly. Pay particular attention to the fuselage width in the canopy and turret opening areas making certain that the fuselage openings match the proper width of the clear parts. The same caution applies to the fit of the injection molded engine cowlings, the injected engine fronts, and the vacuum formed engine cowlings.

SPECIFICATIONS:

WINGSPAN:	21 METERS	BOMB LOAD:	1,000 KG
LENGTH:	16 METERS	MAXIMUM SPEED:	418 KM/H
HEIGHT:	5 METERS	CRUISING SPEED:	330 KM/H
WING AREA:	66.20 METERS²	SERVICE CEILING:	8,700 METERS
EMPTY WEIGHT:	4,650 KG	RANGE:	1,600 KM
GROSS WEIGHT:	7,250 KG	ENGINE TYPE:	2 BRISTOL PEGASUS XXVI RADIALS OF 925 hp EACH

We sincerely hope your new kit brings you many hours of relaxation and enjoyment. Should you wish to contact us(k) in order to compliment our new kit, place additional orders or inform us(k) that we have won the lottery, please use the addresses listed below. All negative comments, criticism, refunds and generally pesky solicitors are required to appear in person at our offices in Ulan Bator.

Aviation Usk
602 Front St., Box 97
Usk, WA 99180

Fax or Phone: (509) 445-1236
E-mail: avusk@povn.com
Web: <http://www.povn.com/avusk>

FOKKER T-V Camouflage & Markings

All aircraft, except the prototype, were painted in this three tone camouflage. Patterns were similar, but as can be seen from existing photos, not identical. It is, of course, best to study photos of the specific aircraft you intend to model. Failing that, use the painting guides we have provided here. The prototype, #850, was originally silver doped overall.

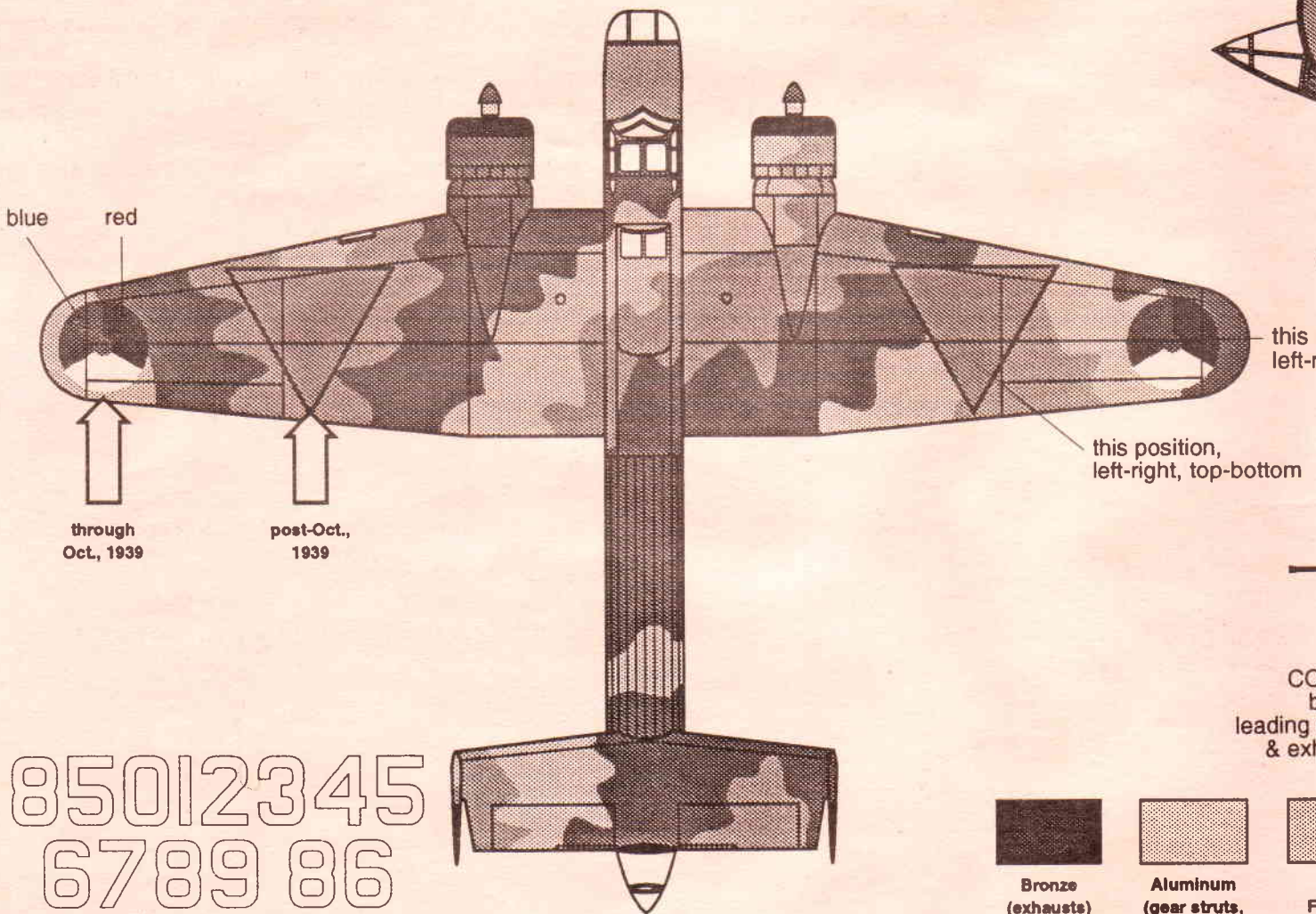

85012345
6789 86



2
serials provided to
construct any Fokker T.V

AVIATION USK: THE HICKEST

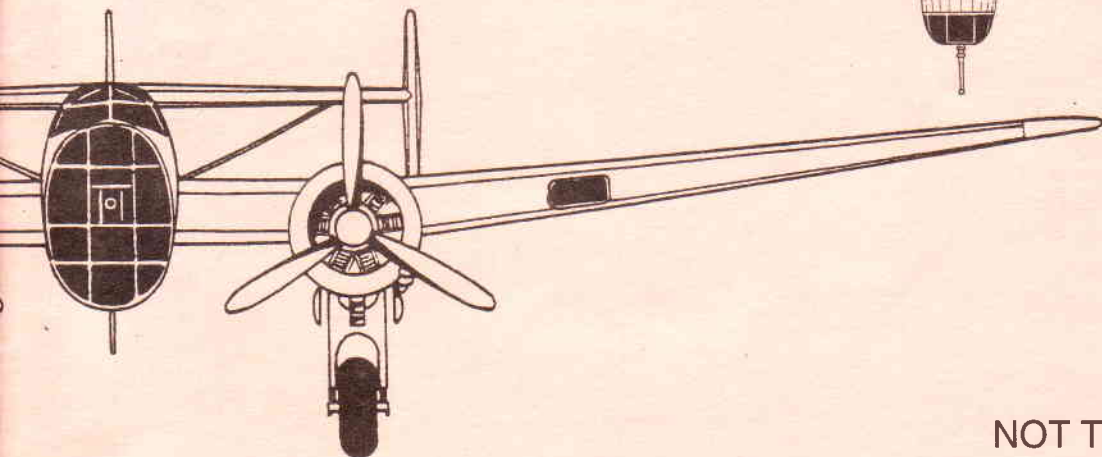
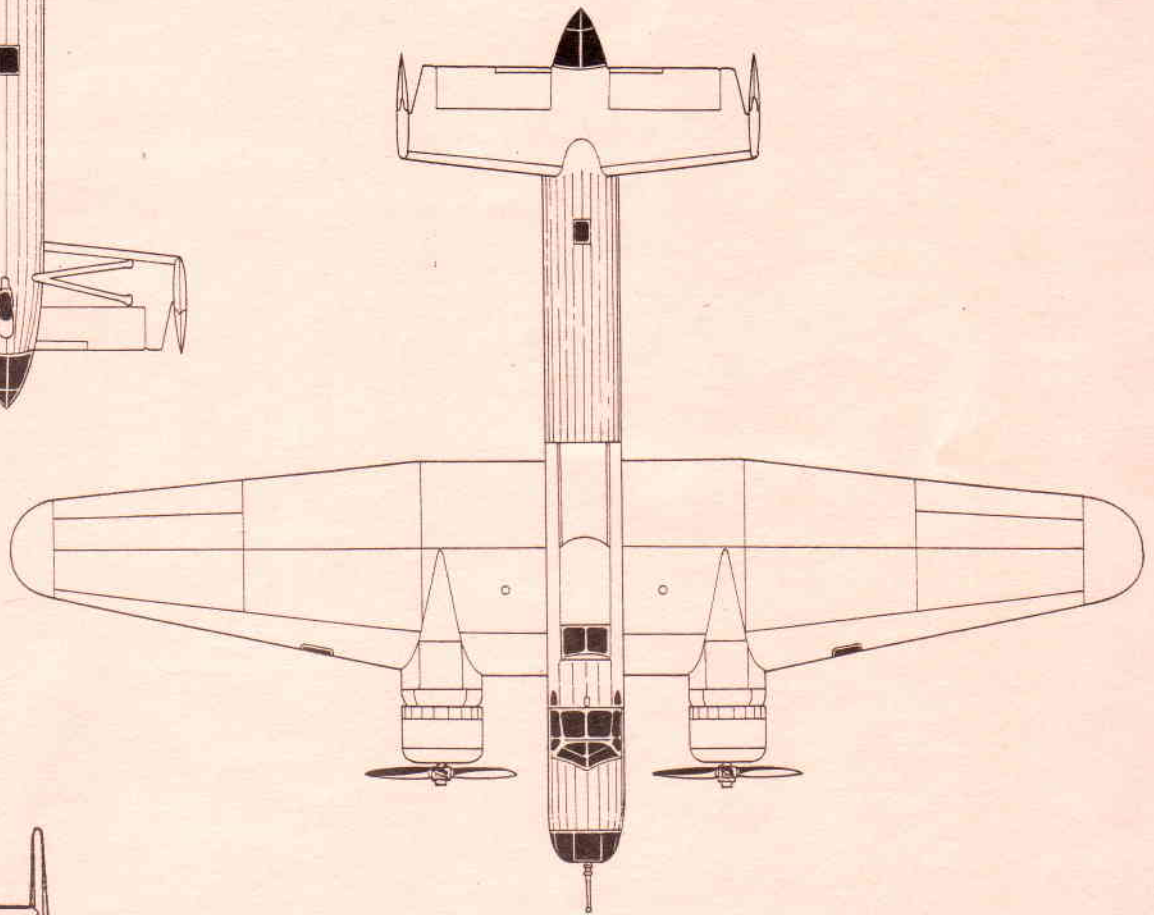
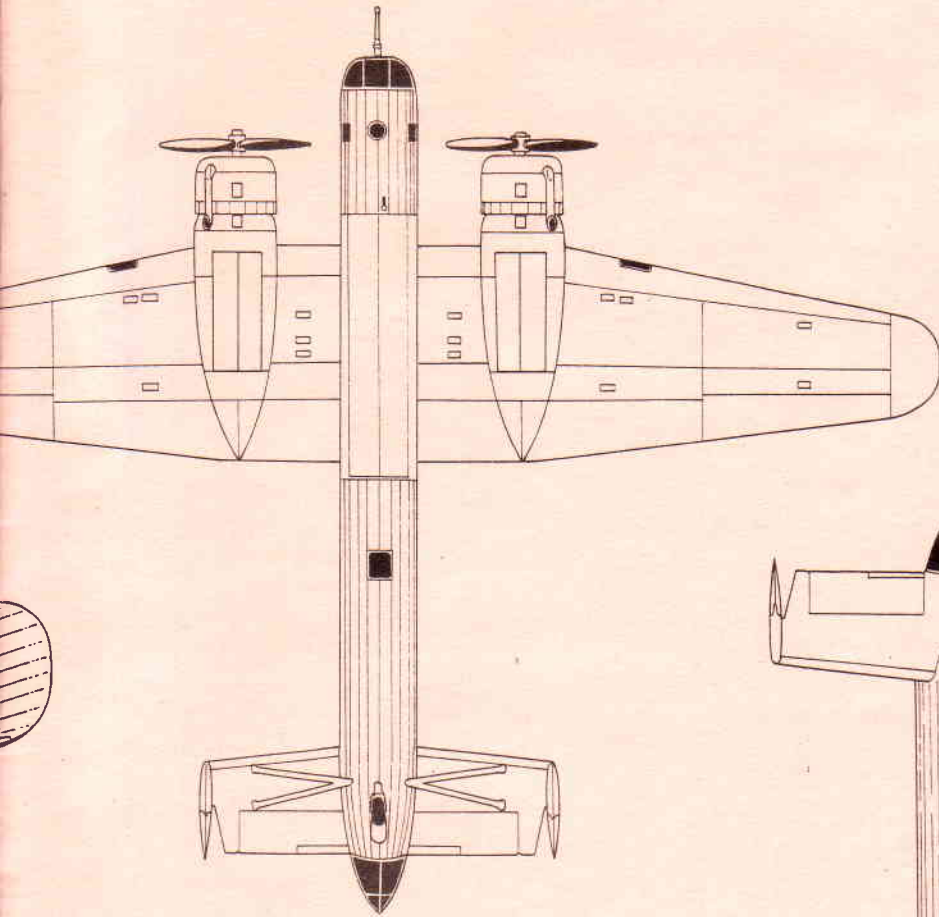

NOT TO SCALE

ILLUSTRATED PARTS BREAKDOWN

FOKKER

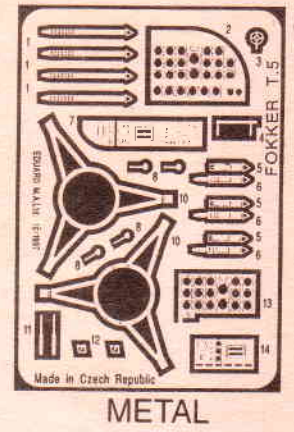
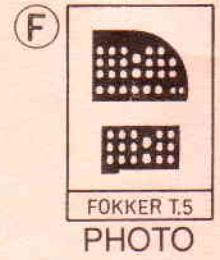
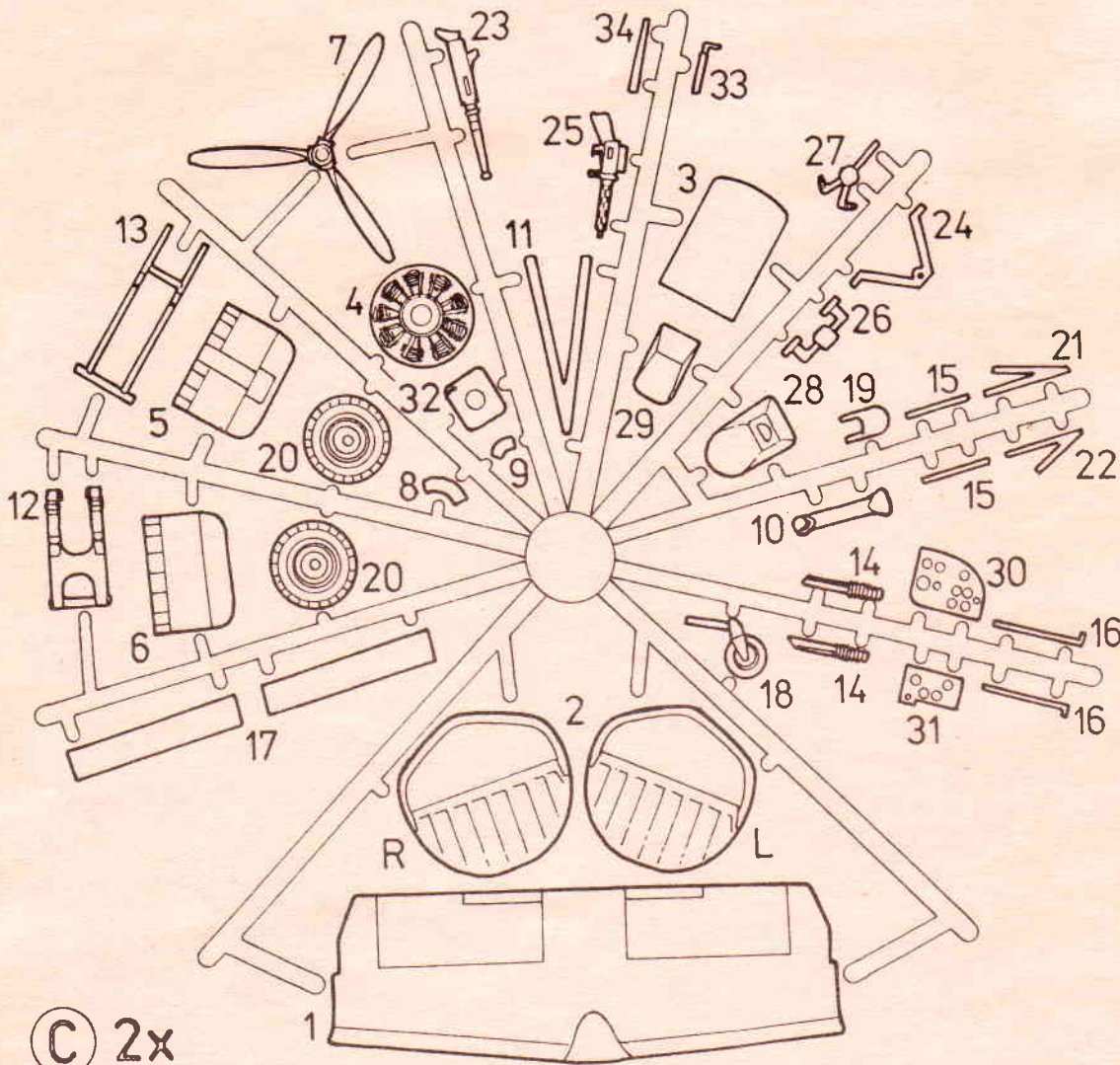

(C) 2x

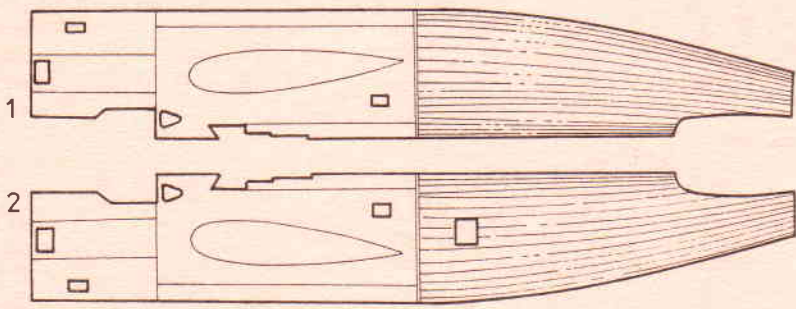

VAC INTERIOR TEMPLATES

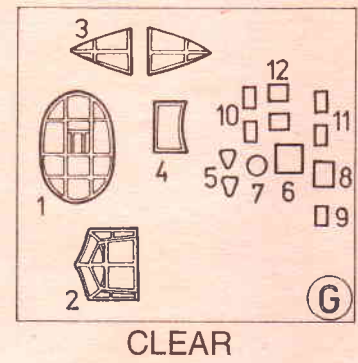
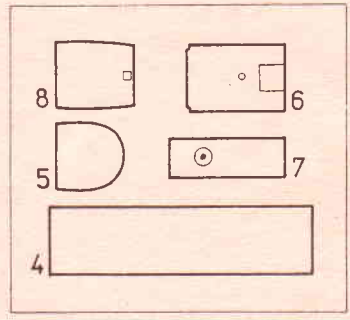
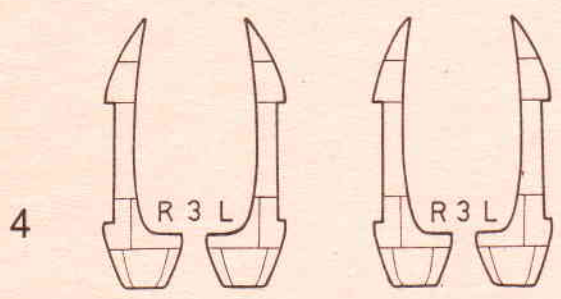

CLEAR

FOKKER T-V

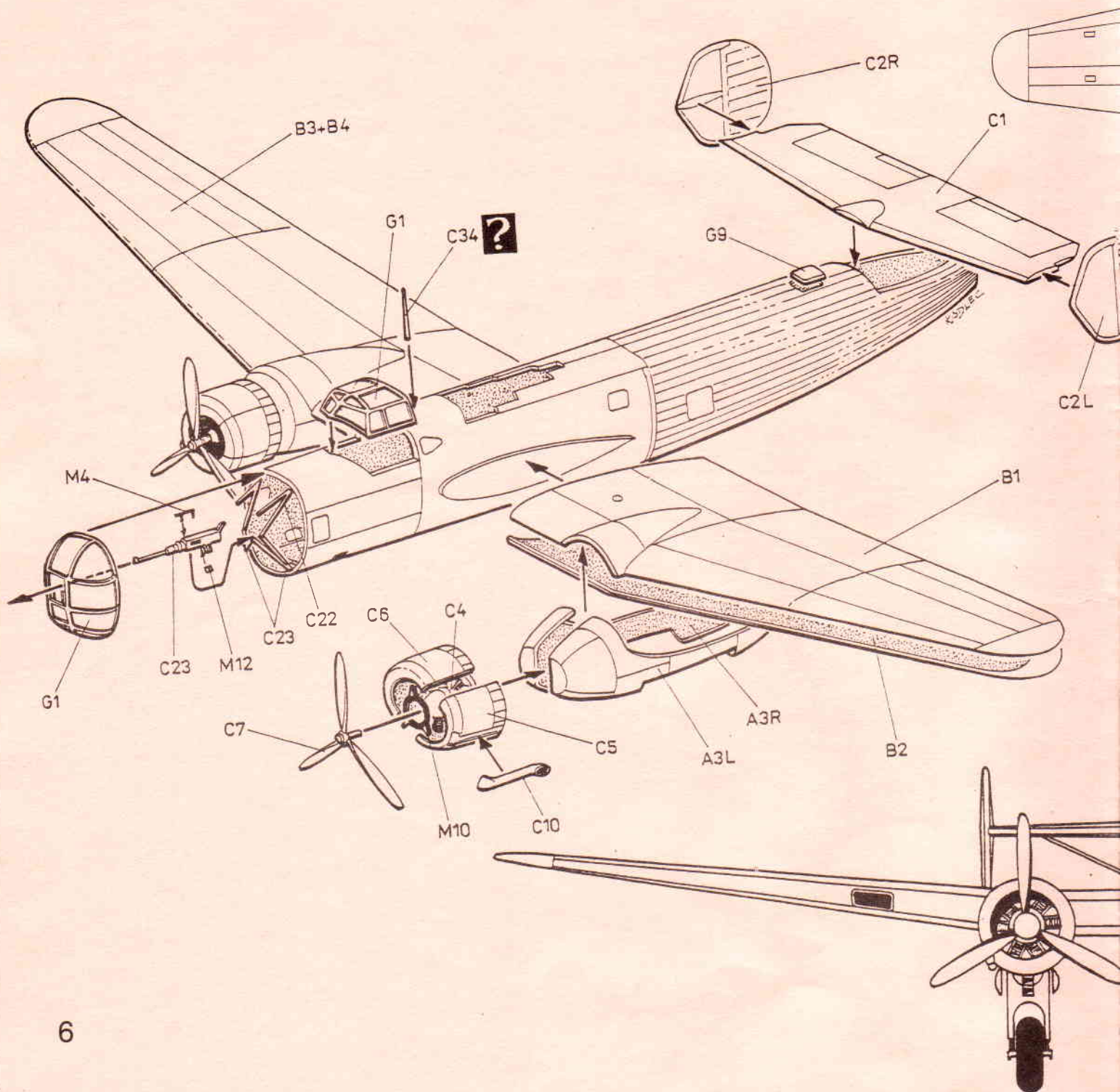

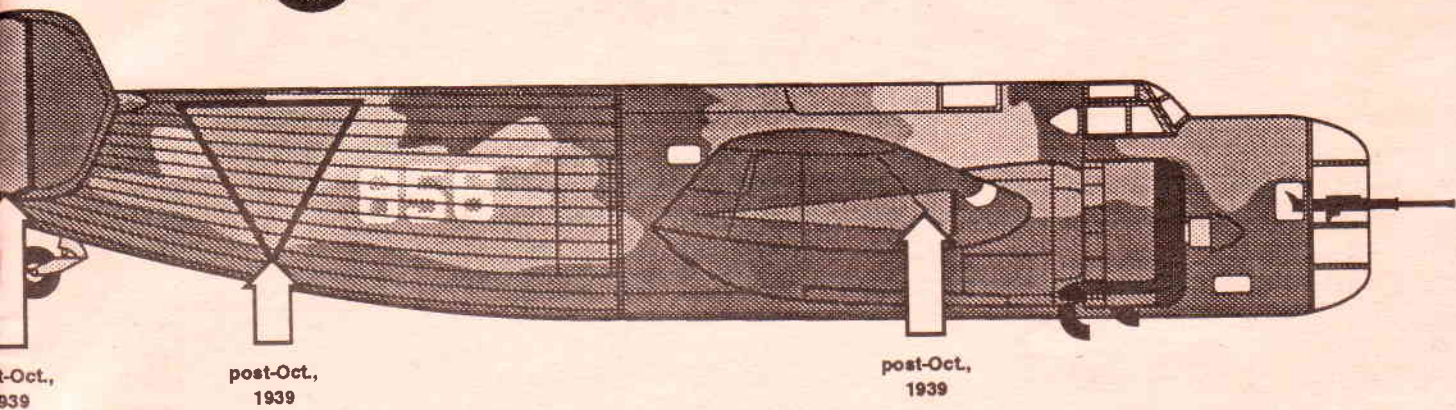
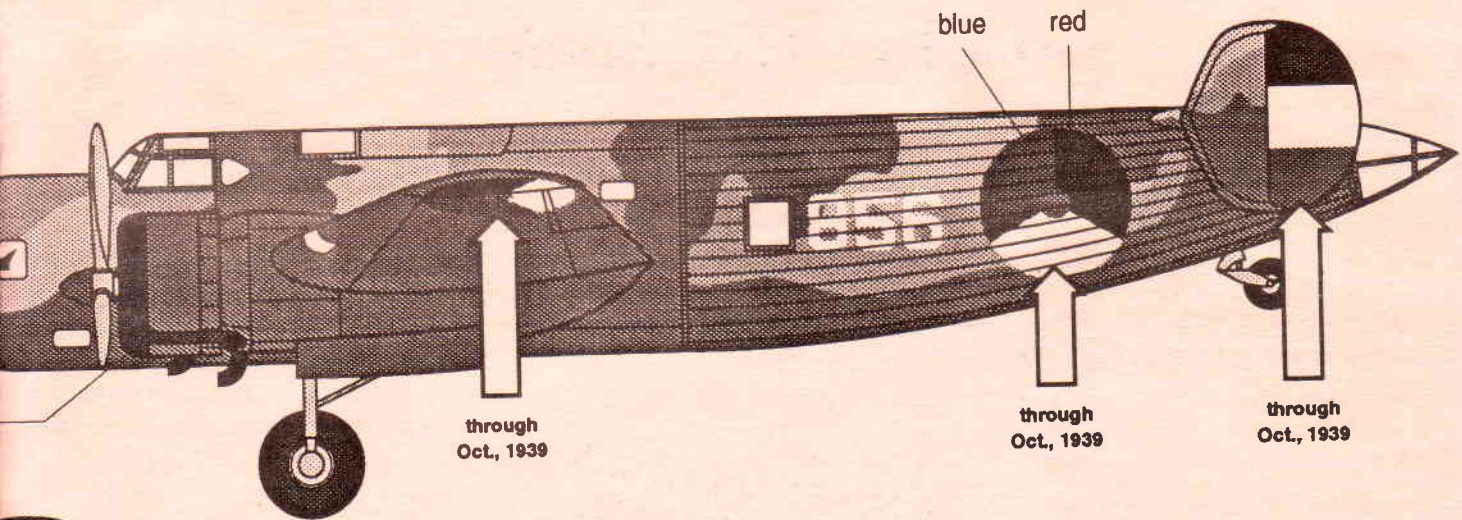

ition,
t, top-bottom;

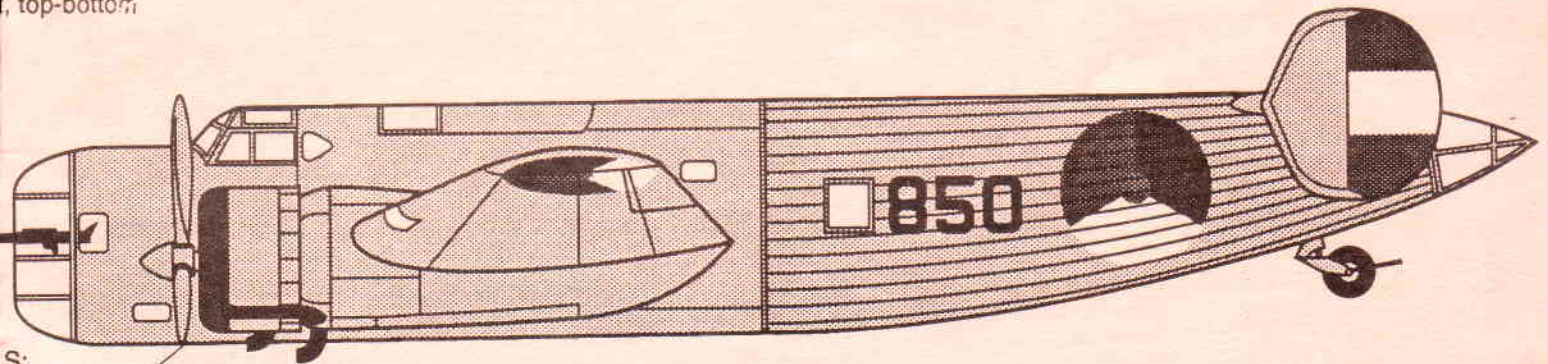

S:
ze
es
sts

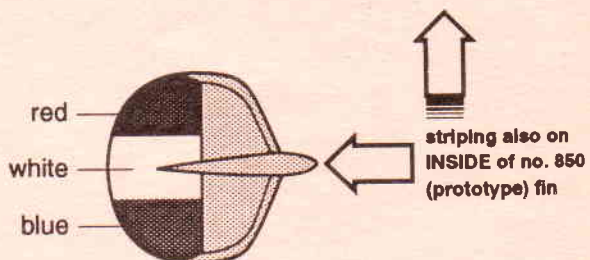
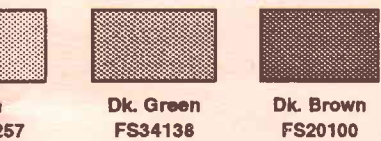

PLACE WITH THE SLICKEST STUFF

AV^USK - 1:72 Seale

Hmmm... What should I build next? *Look no further...* Great Kits from Us(k)!!

Our growing line of limited run injection molded kits has received great magazine reviews and individual modeler response world wide... Our Curtiss Swahawk has been highly praised in modeling mags such as FINE SCALE. More of the earlier kits such as our DAVE, PERRY and PETE have been movin' out. We try to keep our entire line in production at all times; but customers keep messing things up by buying them. Presently, only the KI-115 & MYRSKY are out of stock. The vacuform kits come with their small parts . . . struts and such, injection molded.

Don't Miss Our Latest Kits
AV 1022 • AV 1023

AV1001	KI-115 (TOS)	\$9.95	AV1011	Najajimi "Dave" (Inj.)	\$17.95
AV1002	I-152 (Bagged Inj.)	\$12.95	AV1012	Caproni CA-133 (Vac)	\$17.95
AV1003	F1M "Pete" (Bagged Inj.)	\$17.95	AV1015	Curtiss Seahawk (Inj.)	\$14.95
AV1004	Myrsky (TOS)	\$12.95	AV1016	Italian RO-37 (Inj.)	\$17.95
AV1005	Typhoon IB (Bagged Inj.)	\$14.95	AV1017	B-32 Dominator (Vac)	\$49.95
AV1006	I-15 (Bagged Inj.)	\$12.95	AV1018	SM-82 (Vac)	\$39.95
AV1007	KI-32 "Mary" (Inj.)	\$17.95	AV1019	RO-43 (Inj.)	\$17.95
AV1008	HE-59 (Vac) (<i>Selling Fast!</i>)	\$29.95	AV1020	FIAT RS-14 (Inj.)	\$27.95
AV1009	IK-3 (Inj.)	\$14.95	AV1022	F2G-1 Corsair	\$17.95
AV1010	KI-10 "Perry" (Inj.)	\$17.95	AV1023	Kawanishi E 15K "Norm"	\$23.95

