

F-104 STARFIGHTER G/S

KIT NO. HK72008

1/72 SCALE

HISTORY

The Starfighter, also known in its international versions as Super Starfighter, is one of the most famous and at the same time most debated contemporary planes; so much so that, particularly because of a high percentage of accidents which occurred in West Germany, it was nicknamed rather unflatteringly and unromantically "Widowmaker". There are many causes for these accidents, however, and certainly not all can be put down to the specifications of this beautiful plane.

The USAF asked Lockheed in 1952 for the F-104, as a result of the worrying appearance in Korea of the Mikoyan-Gurevich Mig-15 and of its successors the Mig-17 and the Mig-19.

The USAF General Staff wanted a "fighter for air superiority" which could combat successfully any enemy. As an answer, the famous engineer Clarence Johnson, Technical Director of Lockheed-California, proposed an exceptional plane which could fly at twice the speed of sound.

The F-104 had a very sharp fuselage and a straight wing with a very thin profile and short aspect ratio, a clear derivation of the experimental X-3 and the missile X-7. The craft proved it would fulfill its promises and was made in

record time, in fact the prototype took to the air on February 7th, 1954. In the meantime, however, the war in Korea had ceased and the USAF found it necessary to have a heavier more complicated fighter to integrate their air defence system. The Starfighter, however, as it was relatively economical, became the ideal candidate to re-equip the NATO air forces. In its version F-104G it was ordered by Federal Germany and later on by Belgium, Italy, Norway, Denmark, Greece, Turkey, and Spain; other versions were purchased by Canada, Japan, Pakistan and Taiwan; the Starfighter thus became one of the most widespread fighter planes.

Built for air fighting (F-104G) the F-104 was also adapted for ground attacks and tactical nuclear bombing and some say that it was due to these considerable changes that it had such a high "accident" rate. To replace the F-104G the Italian air force chose in 1965 the F-104S, which was equipped with a turbojet J79-GE-19 (the same as the Phantom II) more powerful than the previous one. Today the F-104S represents the "backbone" of the Italian air force and can certainly be said to be one of the best interceptors in existence.

GENERAL MODELLING

You have a Humbrol Model Kit, each piece of which has been carefully researched and produced to allow you to construct a model kit of which you can be justly proud.

Before commencing the assembly

Study these notes and the assembly instructions before starting the model. Identify the numbered pieces on each of the mouldings with the help of the plans. Make certain you know where pieces fit. Where there is a choice of versions, make certain you know which pieces are required for your intended model. Identify the pieces you have to paint before assembling and those that can be painted after assembling.

Follow the step-by-step instructions carefully.

Assembling and gluing

Carefully cut the pieces from the sprue using a craft knife with a sharp blade. If necessary, trim the pieces with a file or a sandpaper board to ensure a perfect fit.

Before applying cement, assemble the pieces "dry", in order to satisfy yourself that you know where each is located and that they fit perfectly together.

Use the minimum amount of Polystyrene Cement or Liquid Poly, following the instructions for these products. Make certain that pieces are located together to give perfect symmetry in the model.

Certain pieces may need "clamping" together after cementing, until set. Use one or more spring-type clothes pegs or adhesive tape to assist you to get a perfect joint.

Use a pair of tweezers to assist you in assembling the smaller components. Polystyrene Cement and Liquid Poly will not adhere to plated or painted plastic, so carefully scrape away the plating from the points of assembly before applying cement. Any small gaps in the model can be filled using Humbrol Model Filler.

Painting
Use Humbrol Enamels for painting your model. Follow the instructions as to which pieces to paint before or after assembly. To matt down a gloss paint use Matt Varnish No. 49. When intermixing paints to obtain a particular shade, make certain that you mix sufficient for the job in hand.

Positioning of decals
Identify the position for each decal on the model according to the version chosen by following the plans. Carefully cut round the decal, soak for a few seconds in luke warm water, carefully slide from the backing paper into the correct position. Absorb excess water with a small piece of blotting paper or soft clean rag. Tools and materials usually recommended and used for modelling (files, pins, craft knife, cements, solvents, paints, etc.) can represent a danger if entrusted to children without the control of a parent. All modellers should exercise care in the use of heat or naked flames and the use of these should not be attempted by a young person under any circumstances.

The above advice is not given lightly and we kindly ask you not to ignore it.
Thank You . . . Happy Modelling

PAINTING

We recommend the use of Humbrol Britfix Polystyrene Cement or Humbrol Britfix Liquid Poly to assemble your model, and the following Modelling Paints for a perfect finish.

Humbrol Colour Reference Numbers	
27 Sea Grey	116 US Dark Green
34 White	117 US Light Green
56 Aluminium	118 US Tan
85 Coal Black	129 Gull Grey

These are the colours required for the overall finish. For opened panels and some wing stores a small amount of 24 Trainer Yellow and 82 Orange Lining will be required.

IN CASE OF COMPLAINT

Your Humbrol Plastic Model kit has been carefully moulded and packed. Should you be in any way dissatisfied with the kit please write to the address below stating the nature of your complaint or the part number(s) required, the kit number, your name, address and post code.

The Sales Department,
Model and Hobby Division,
Humbrol Ltd., Marfleet, Hull HU9 5NE



Sabca Lockheed F 104 G
Force Aerienn Belge
10th Fighter bomber Wing

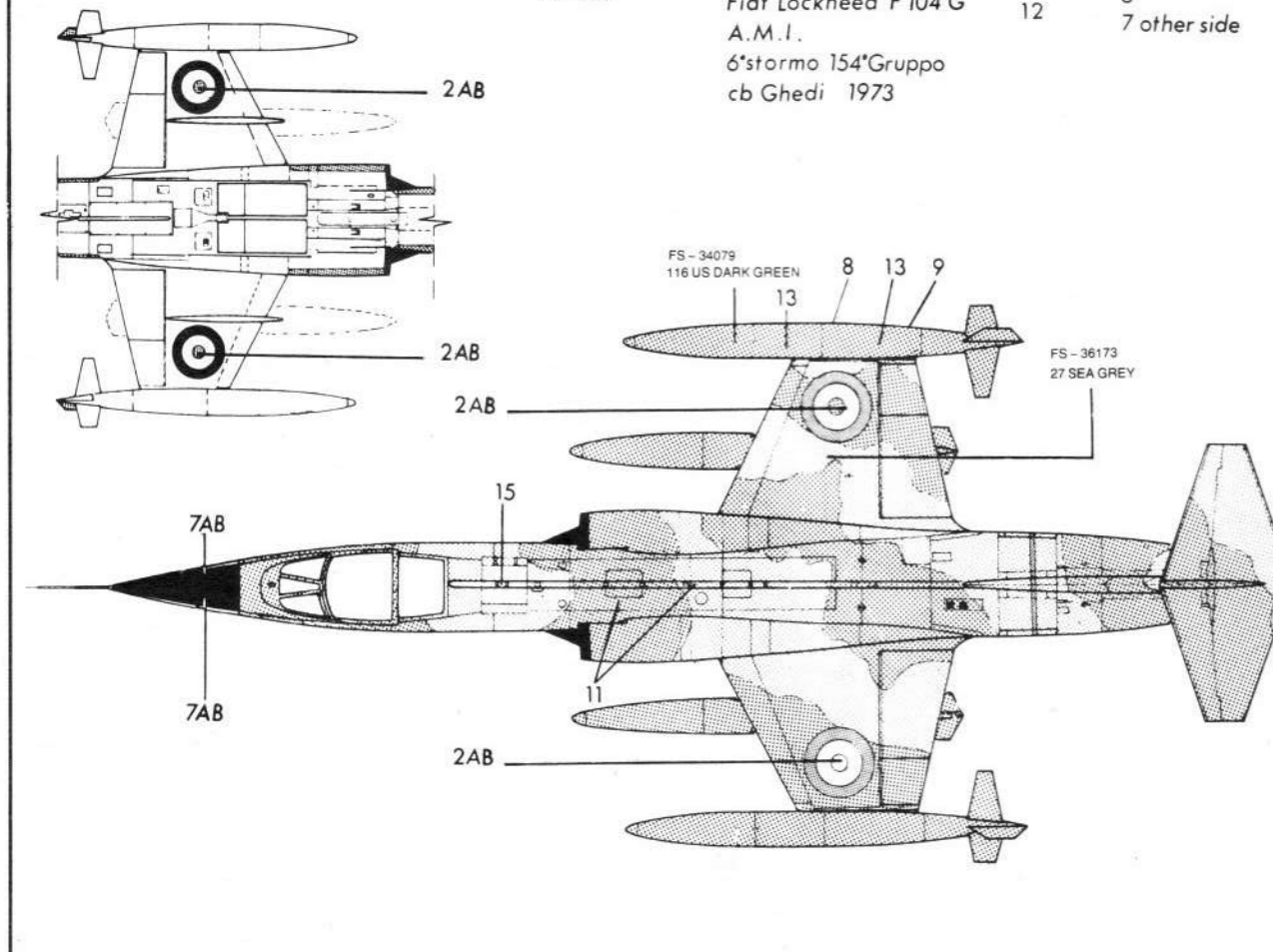
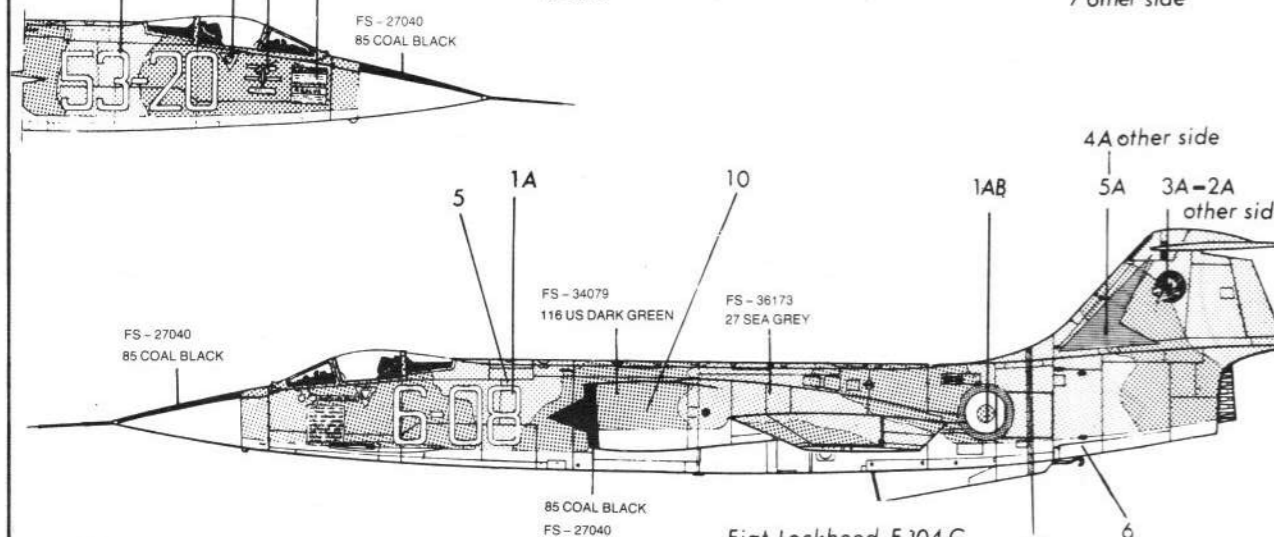
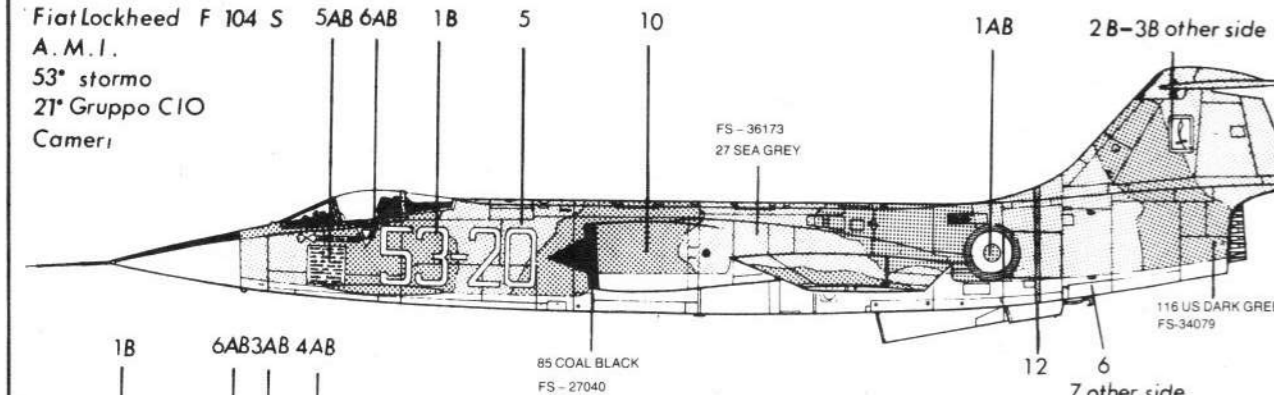
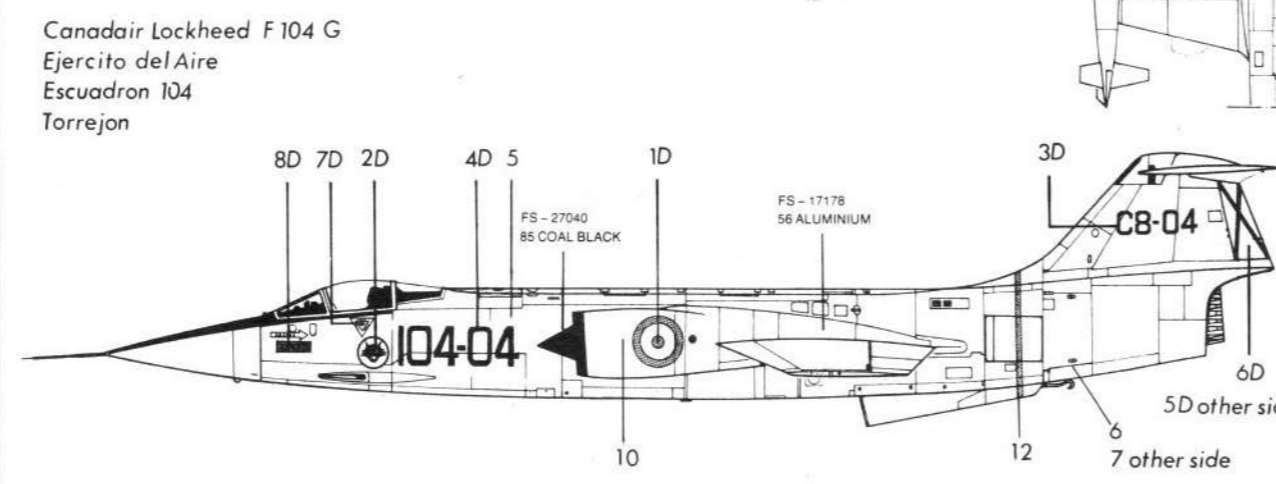
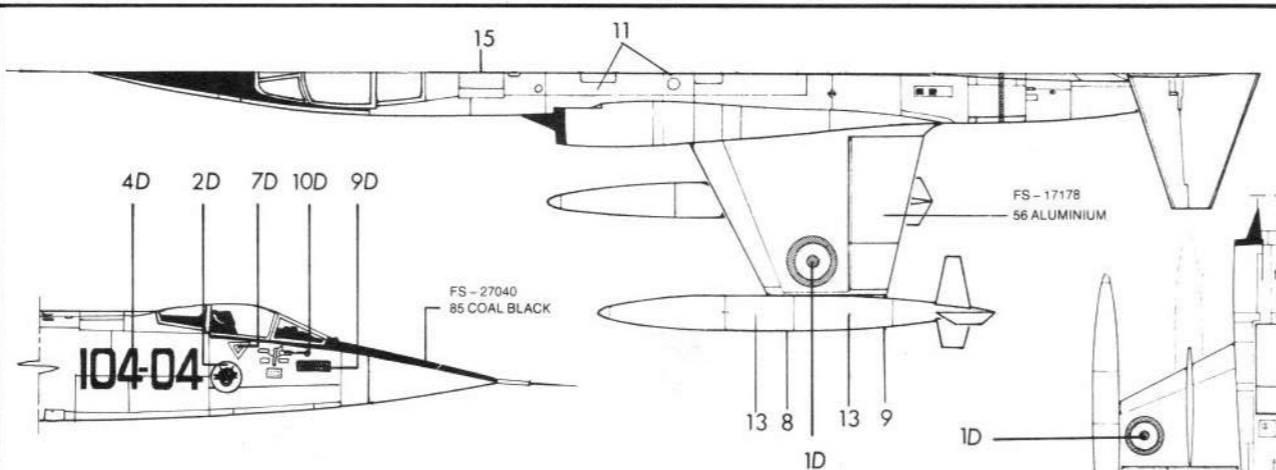
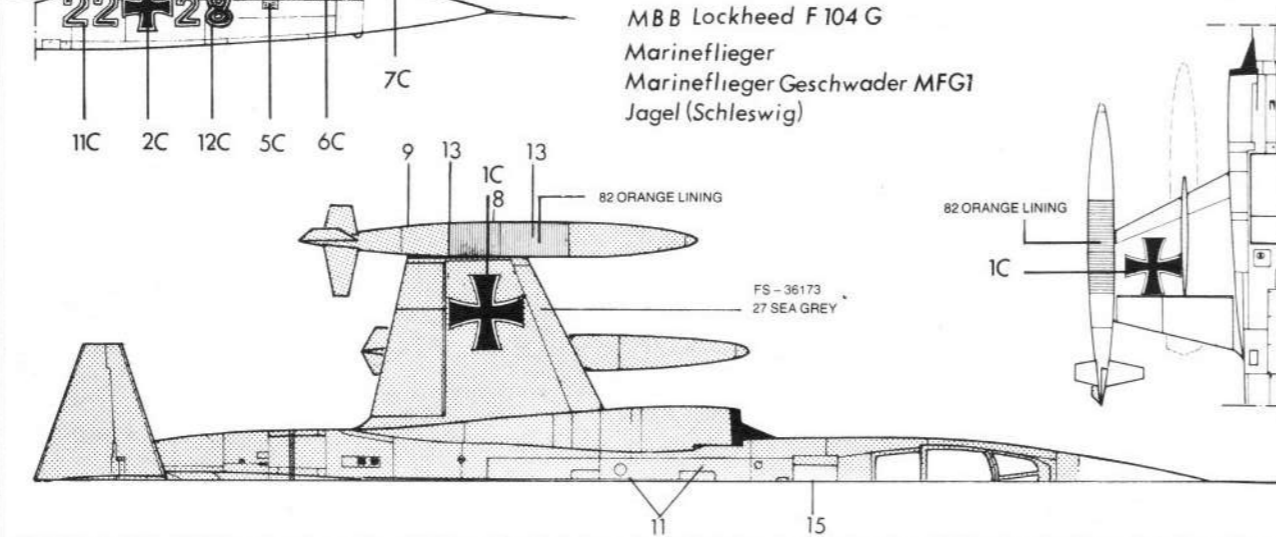
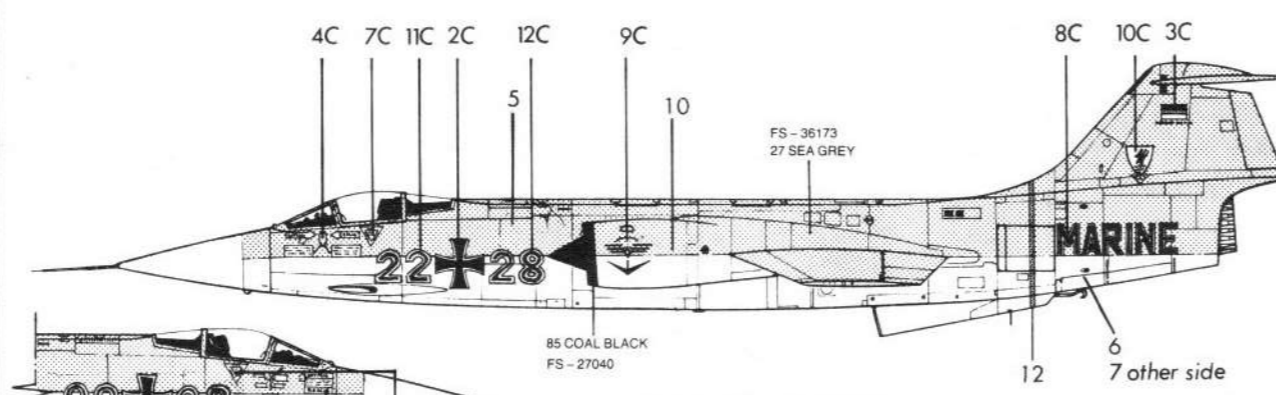
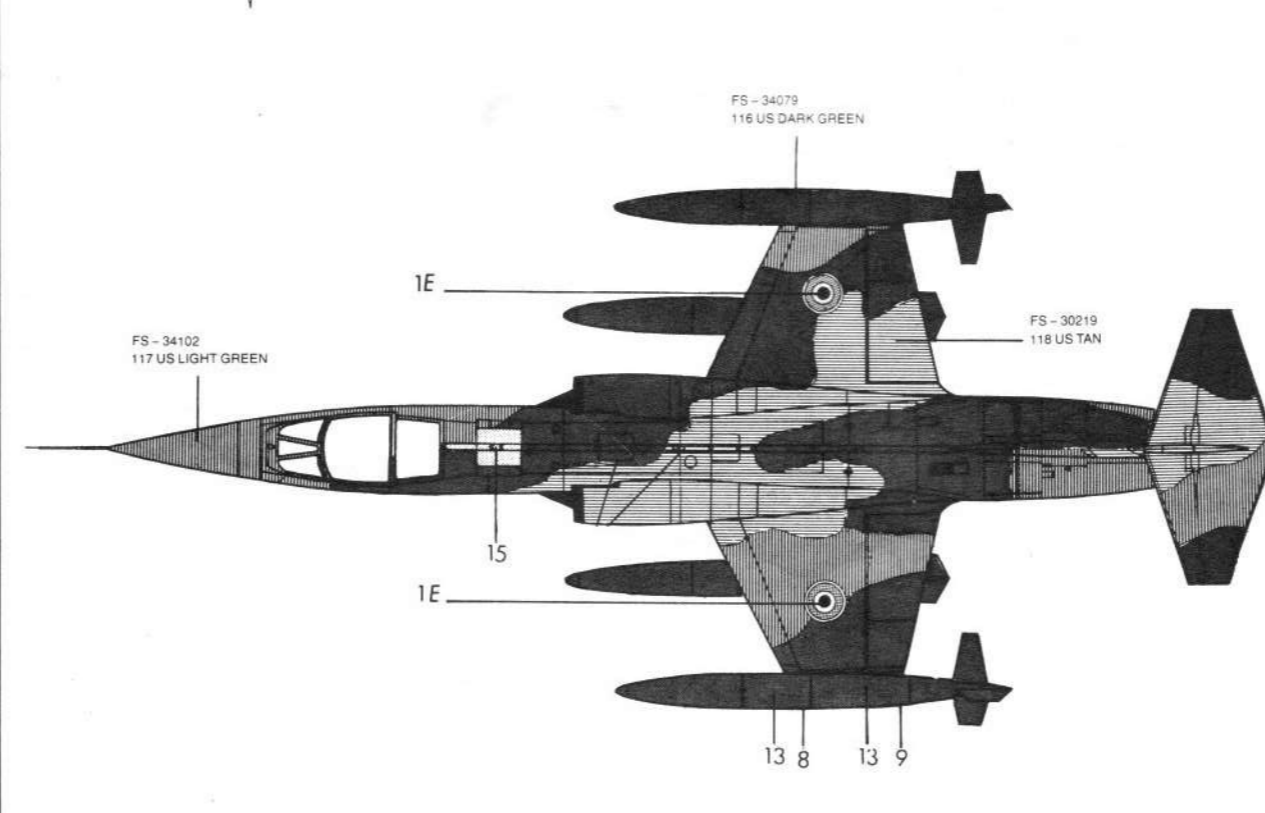
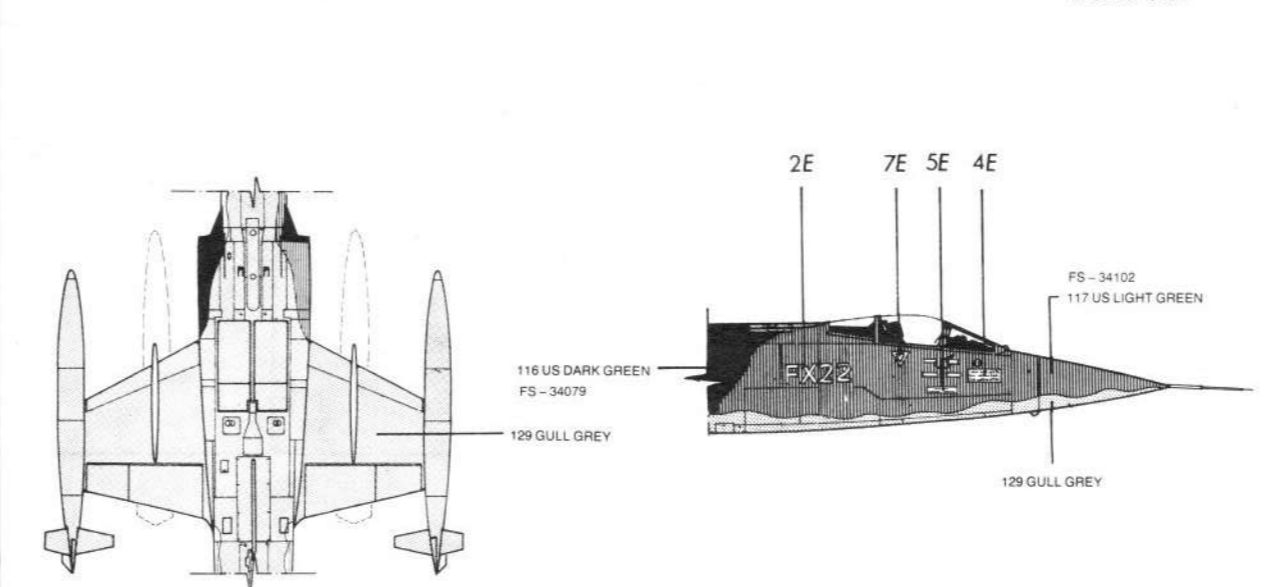
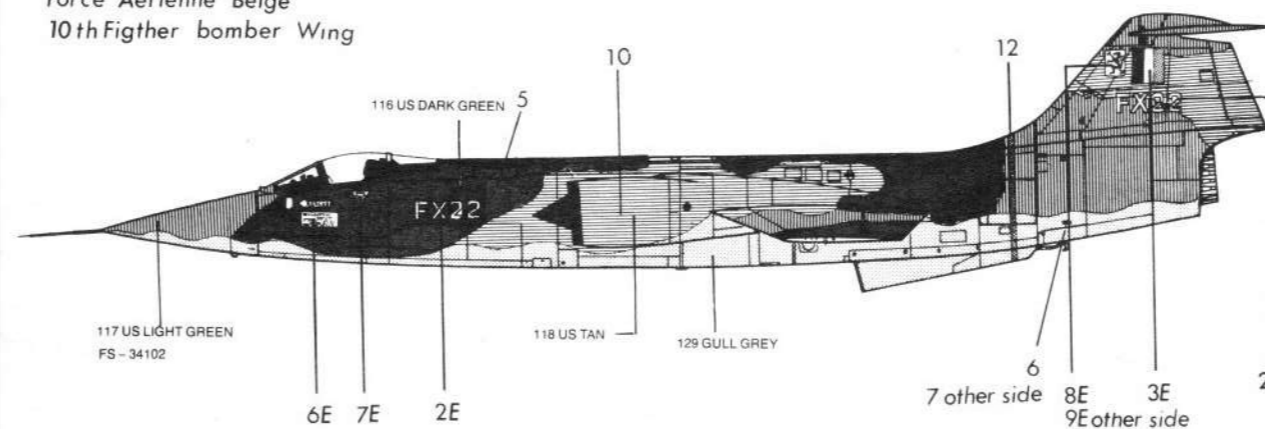

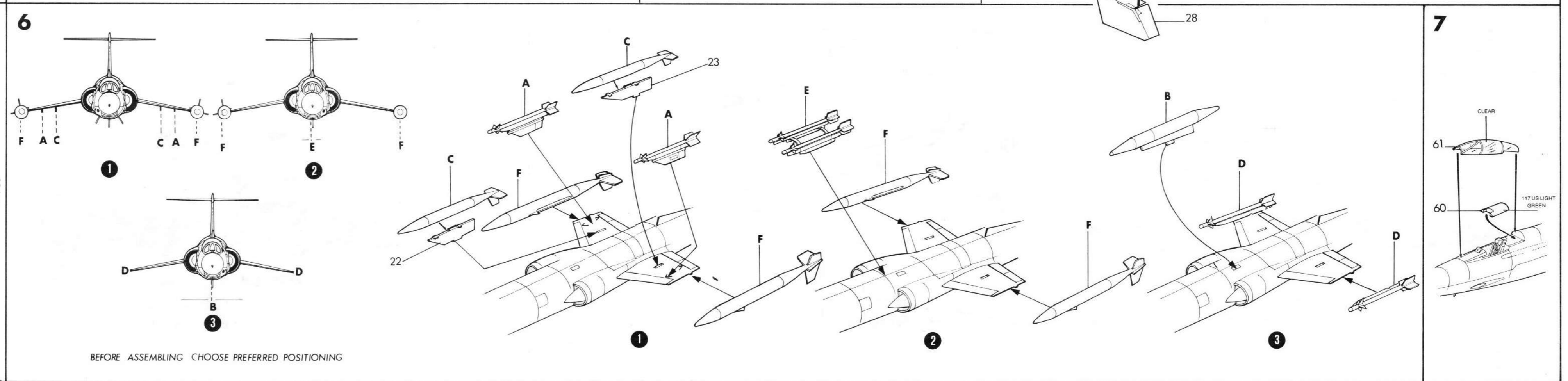
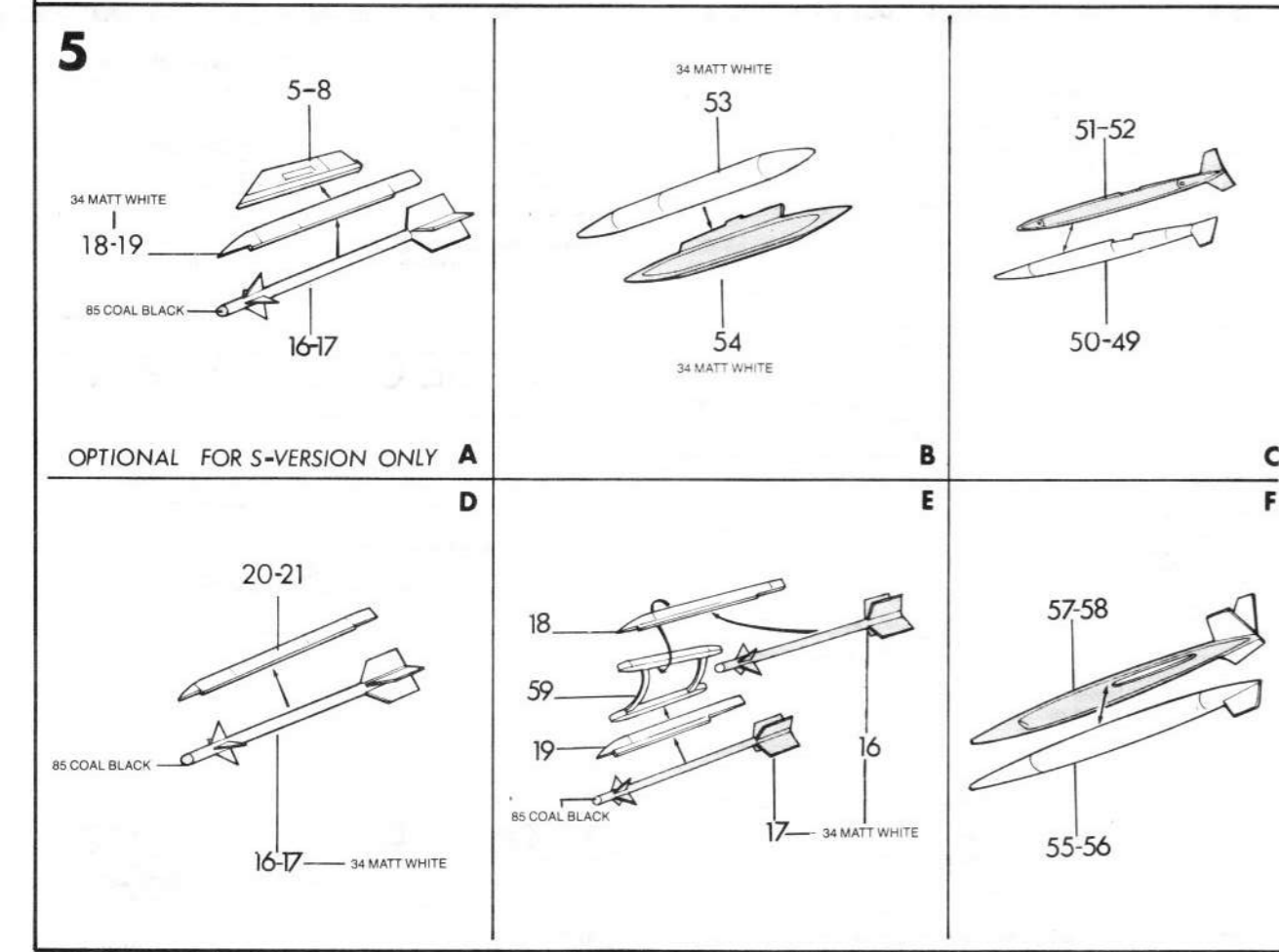
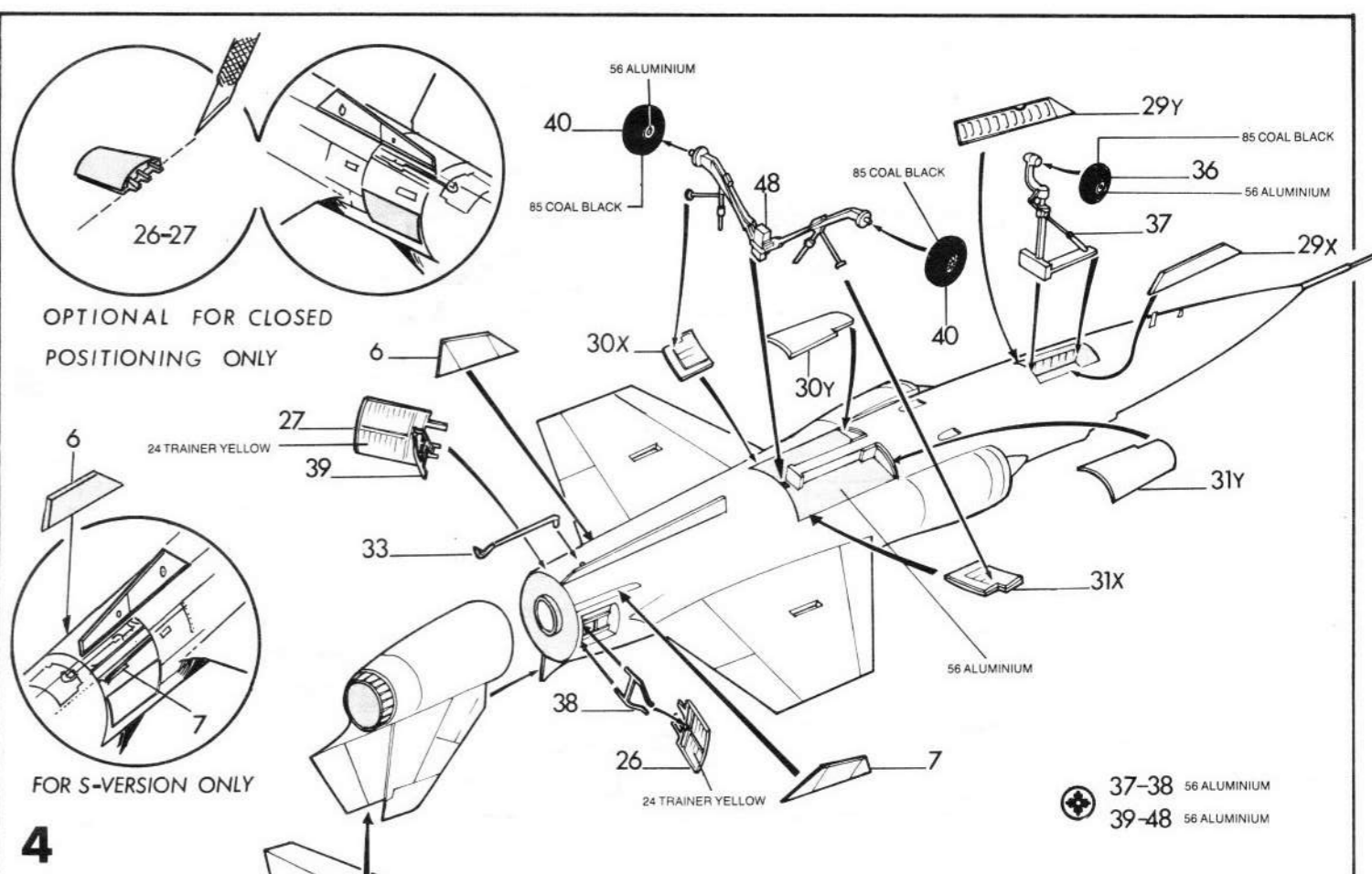
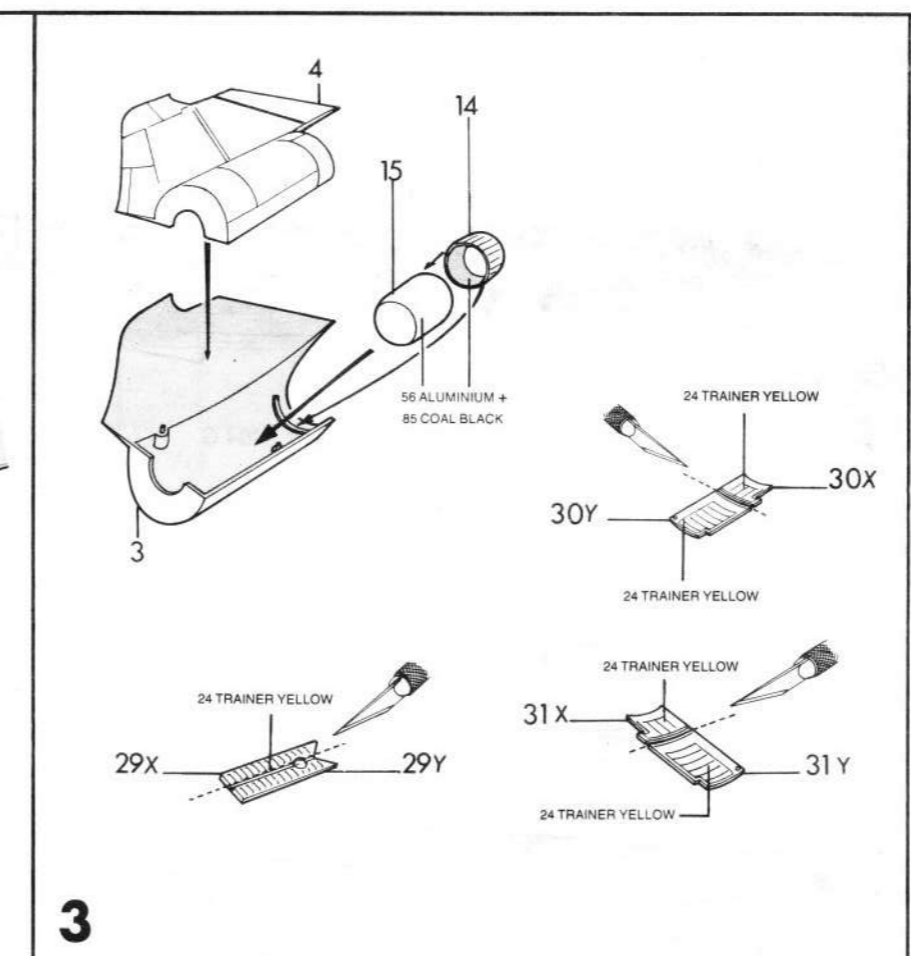
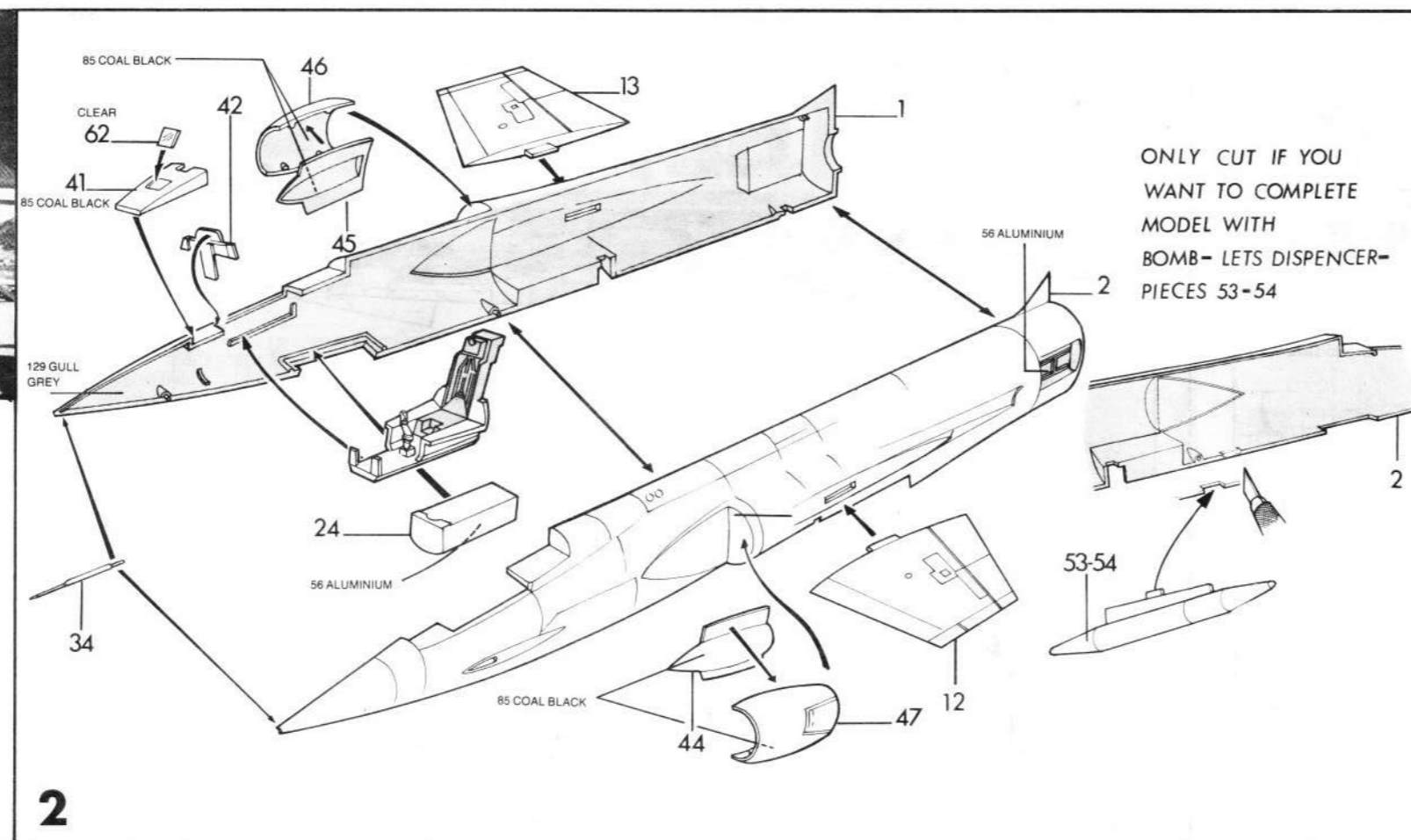
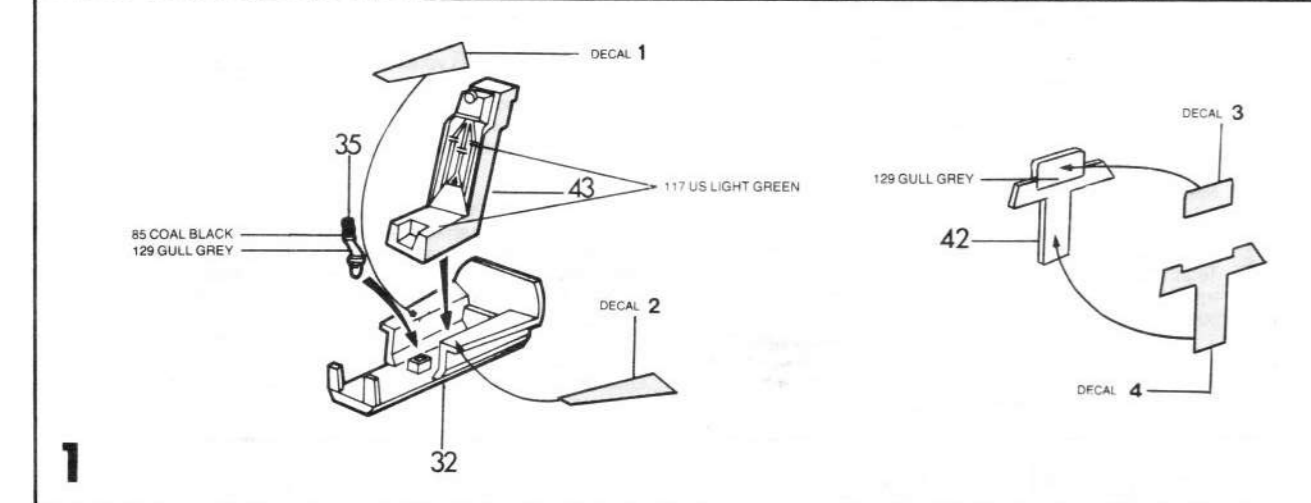
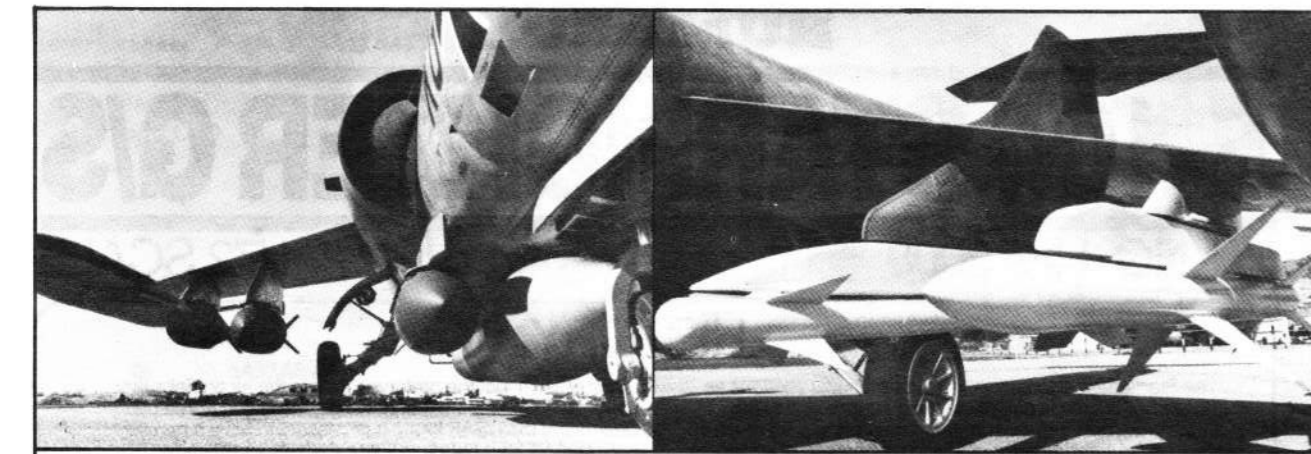

2 3 1 15 7 6 13 13 10 8 14 14 5 12 11

CAUTION

A-B

7 3 2 2 1 2 2 2

4 6

5

B

2 3

53:20

1

53:20

C

1 1 1 1

2 2

MARINE 8

MARINE 8

3 3

9 9

11 11

22 22

28 28

10 10

6

4 4

7 7

5

6:08

1

6:08

3

4 5

7

A

8 9

1 1 1

C8-04

3

C8-04

10

D

1 1

7

8 9

FX22 FX22

2

FX22 FX22

4 5 6

3 3

E

D-8062

1 2 3 1

4 4

F

2 2

6

8

9

4

D-8062

7

6

8

9

4

D

104-04

104-04

4

D