



Fiat 131 Rallye

1975 sah sich die Rennwagenabteilung des Fiat-Konzerns mit dem Problem konfrontiert, einen adäquaten Nachfolger für den in die Jahre gekommenen Fiat 124 Spider zu finden. Gemäß dem Konzept „Mittelklassewagen für siegreiche Rennen“ fiel die Wahl auf den Fiat 131. Der Tuningspezialist Abarth begann unverzüglich mit den Vorbereitungen an dem Serienmodell. Die überwiegenden Veränderungen fanden sich an der Karosserie, bei der jetzt viel Kunststoff- und Aluminiumteile verwendet wurden, um das Eigengewicht des Fahrzeugs spürbar zu senken. Der Motor entstammte dem Modell 132, besaß 1995 ccm Hubraum und bot in der Rallyevariante 235 PS Leistung bei 7500 Umdrehungen in der Minute. Das Debüt des 131 Abarth fand 1975 auf nationaler Ebene statt. Schon im zweiten Rennen belegte das Fahrzeug den ersten Platz und hatte damit seine Bewährungsprobe bestanden. Nach Erfüllung der Homologationsverpflichtung in Höhe von 400 gefertigten Modellen des Fiat 131 Abarth wurde das Fahrzeug am 1. April 1976 für Rennen der Gruppe 4 zugelassen und konnte damit ab diesem Datum an internationalen Rennen teilnehmen. Nach einer zufriedenstellenden Leistung in Marokko überzeugte der 131 durch den Sieg des Teams Alén-Kivimäki in Finnland bei der 1000-Seen-Rallye. Da das Rennen ohne besondere Vorbereitung angegangen war, überzeugte dies die Fiat Rennleitung, die Bemühungen für die Folgesaison zu intensivieren. 1977 gewann der Fiat 131 Abarth den Weltmeistertitel, der 1978 wiederholt wurde. Dennoch gilt der Sieg in Monte Carlo 1980 als der bedeutendste des Fahrzeugs. 1928 hatte Fiat das letzte Mal auf dieser Strecke gewonnen. Dabei war der Sieg keineswegs sicher. Denn die Vorbereitung zur Rallye dauert länger als geplant, drei Tage vor Weihnachten verlangt das Werksteam entgegen den Abmachungen mehr Test. Der deutsche Fahrer Walter Röhrl pocht auf die Einhaltung der Zusagen und der 22-jährige Regensburger verlässt über die Feiertage das Team. Danach kehrt er, noch immer wütend, gemäß der vorherigen Abmachungen termingerecht vor dem Rallye Start zurück. Die ersten Wertungsprüfungen legt der begnadete Fahrer in Jeans und Hemd zurück. Die Rallye Monte Carlo wird extrem schwierig. Schnee, Nebel und dann wieder Sonne diktiert das Bild, über Nacht bilden sich zahllose, gefährliche Eisflächen, die der Perfektionist mit über 180 Stundenkilometern nervenstark und fehlerlos nimmt. Selbst auf der 38 Kilometer langen Sonderprüfung nach Antraigues, der Parade Strecke seines Teamkollegen Andruet, die sich an einem Hang entlang windet, ohne Leitplanke, aber dafür mit tiefen Abgründen, reichlich Eis und Schnee, beweist der spätere zweifache Rallye-Weltmeister Nervenstärke. Die Orangen, die er mit sich führte, bewegen sich im Fahrzeug und klemmen sich unter die Pedale. Röhrl und sein Beifahrer Christian Geistdörfer lösen die Gurte und werfen bei jedem Bremsvorgang eine Frucht weg, bis das Problem behoben ist. Trotz dieses Handicaps holen sie einen souveränen Vorsprung von 40 Sekunden heraus. Am Ende der verschneiten, oft vergregneten Rallye gewinnt Röhrl, der Jahre später zum besten Rallye-Fahrer aller Zeiten gekürt werden wird, das erste Mal in Monte Carlo und erringt damit einen der wichtigsten Siege in der Renngeschichte des Fiat 131 Abarth.

Fiat 131 Rally

In 1975 the Fiat racing car division was confronted by the problem of how to find an adequate successor for the ageing Fiat 124 Spider. According to the concept "medium range car for victorious races" the choice fell on the Fiat 131. Without delay the tuning specialist Abarth began the preliminaries on the production model. The chief modifications were made on the bodywork on which many plastic and aluminium parts were now used in order to appreciably reduce the intrinsic weight of the car. The engine originated from the model 132, had 1995 cc and offered an output of 235 bhp at 7500 rpm. The 131 Abarth made its debut on a national level in 1975. Already in the second race the car took first place and had therefore passed its test. After meeting its homologation requirements of 400 completed models of the Fiat 131 Abarth, on 1st April 1976 the car was approved for Group 4 races and from that date onwards was able to take part in international races. After a satisfactory performance in Morocco the 131 brought in a convincing victory for the team Alén-Kivimäki in the 1000 Lakes Rally in Finland. As the race was started without any special preparation, this persuaded the Fiat racing management to intensify the arrangements for the following season. In 1977 the Fiat 131 Abarth won the world championship title and repeated the feat in 1978. Then the win in 1980 in Monte Carlo was considered to be the most important for the car. 1928 was the last time Fiat had won on that course. However the win was in no way certain. As the preparations for the rally lasted longer than planned and three days before Christmas the works team asked for more testing, contrary to the arrangements. The German driver Walter Röhrl insisted that they abide by the arrangements and the 22-year-old from Regensburg left the team over the holidays. He then came back, still furious, just in time to start the rally in accordance with the prior agreement. The inspired driver took part in the first classification trials in jeans and shirt. The Monte Carlo Rally is extremely difficult. Snow, fog and then some sun dictated the pace. Overnight innumerable patches of dangerous ice formed, which the perfectionist took faultlessly and with a steady nerve at over 180 km/h. On the 38 km long special test section after Antraigues, the parade ground of his team colleague Andruet, that wound along a mountain road overhanging steep precipices without crash barriers, but with plenty of ice and snow, the man who would twice become world rally champion really showed the strength of his nerve. The oranges he carried with him moved about in the car and got stuck under the pedals. Röhrl and his co-driver Christian Geistdörfer loosened their belts and threw out a piece of fruit each time the driver braked until the problem was eliminated. Despite this handicap they pulled out a mighty 40 seconds lead. At the end of the snowy, often rainy rally Röhrl, who years later would be named the best rally driver of all time, won at Monte Carlo for the first time and carried off one of the most important victories in the racing history of the Fiat 131 Abarth.

Benötigte Farben / Used Colors

Benötigte Farben Required colours	Peintures nécessaires Benodigde kleuren	Pinturas necesarias Tintas necessárias	Colori necessari Använda färger	Tarvittavat värit Du trenger følgende farger	Nødvendige farver Необходимые краски	Potrzebne kolory Απαιτούμενα χρώματα	Gerekli renkler Potřebné barvy	Szükséges színek. Potrebne barve
A aluminium, metallic 99 aluminium, metallic aluminium, métallique aluminium, metallic aluminio, metalizado aluminio, metálico aluminio, metalico aluminium, metallic aluminium, metallic aluminium, metallikiilto aluminium, metallak aluminium, metallic алюминиевый, металл aluminium, metalliczny αλουμινίου, μεταλλικό aluminium, metalik hliníková, metaliza aluminium, metall aluminium, metalik	B schwarz, seidenmatt 302 black, silky-matt noir, satiné mat zwar, zijdemat negro, mate seda preto, fosco sedoso nero, opaco seta svart, sidenmatt musta, silkinihimmä sort, silkematt sort, silkematt черный, шелковисто-матовый czarny, jedwabisto-matowy μαύρο, μεταξωτό ματ siyah, ipek mat černá, hedvábně matná fekete, selyemmatt črna, svila mat	C silber, metallic 90 silver, metallic argent, métallique zilver, metallic plata, metalizado plata, metálico argento, metalico silver, metallic hopea, metallikiilto salv, metallak salv, metallic серебристый, металл srebro, metaliczny οσημί, μεταλλικό gümüş, metalik stříbrná, metaliza ezüst, metall srebrna, metalik	D anthrazit, matt 9 anthracite grey, matt anthracite, mat antraciet, mat antracita, mate antracite, fosco antracite, opaco antraicit, matt antrasiitti, himmeä koksgrå, mat antrasit, matt антрацит, матовый srebro, metaliczny σπινθη, μεταλλικό demir, metalik železná, metaliza vas, metall železna, metalik	E eisen, metallic 91 steel, metallic coloris fer, métallique ijzerkleurig, metallic ferroso, metalizado ferro, metálico ferro, metalico jäämärg, metallic teräksenvärinen, metallikiilto jern, metallak jern, metallic стальной, металл železowy, metaliczny σιδηρού, μεταλλικό demir, metalik železná, metaliza vas, metall železna, metalik	F braun, seidenmatt 381 brown, silky-matt brun, satiné mat bruin, zijdemat marrón, mate seda castanho, fosco sedoso marrone, opaco seta brun, sidenmatt ruskea, silkinihimmä brun, silkematt brun, silkematt коричневый, шелковисто-матовый brązowy, jedwabisto-matowy καφέ, μεταξωτό ματ kahverengi, ipek mat hnědá, hedvábně matná barna, selyemmatt rjava, svila mat			

G	H	I	J	K	50 %	L	50 %
farngrün, seidenmatt 360 green, silky-matt vert fougère, satiné mat varengroen, zijdemat verde helecho, mate seda verde feto, fosco sedoso verde felice, opaco seta ornbunnsgrön, sidenmatt sanaisensivihreä, silkinihimmä bregnegrøn, silkematt bregnegrønn, silkematt зелен, папоротник, шелк.-матовый zielony paprós, jedwabisto-matowy πράσινο φτέρης, μεταξωτό ματ egreittitu yeşilli, ipek mat krapradinov zelená, hedvábně mat. párfányzöld, selyemmatt paprot zelena, svila mat	hellgrau, seidenmatt 371 light grey, silky-matt gris clair, satiné mat lichtgrijs, zijdemat gris claro, mate seda cinzento claro, fosco sedoso grigio chiaro, opaco seta ljusgrå, sidenmatt vaaleanharmaa, silkinihimmä lysegrå, silkematt lysgrå, silkematt светло-серый, шелковисто-матовый jasnoszary, jedwabisto-matowy ανοιχτό γκρι, μεταξωτό ματ açık gri, ipek mat světlesedá, hedvábně matná világoszürke, selyemmatt svetlo siva, svila mat	weiß, glänzend 4 white, gloss blanc, brillant wit, glansend blanco, brillante branco, brilhante bianco, lucente vit, blank valkoinen, kiiltävä hvid, skinnende hvít, blank белый, блестящий biały, błyszczący λευκό, γυαλιστερό beyaz, parlak bilá, lesklá fehér, fényes bela, bleskajoča	grau, seidenmatt 378 grey, silky-matt gris, satiné mat grijs, zijdemat gris, mate seda cinzento, fosco sedoso grigio, opaco seta grå, sidenmatt harmaa, silkinihimmä grå, silkematt серый, шелковисто-матовый szary, jedwabisto-matowy γκρι, μεταξωτό ματ gri, ipek mat šedá, hedvábně matná szürke, selyemmatt siva, svila mat	schwarz, matt 8 black, matt noir, mat zwart, mat negro, mate preto, fosco nero, opaco svart, matt musta, himmeä sort, matt sort, matt черный, матовый czarny, matowy μαύρο, ματ siyah, mat černá, matná fekete, matt črna, mat	purpurrot, seidenmatt 331 purple red, silky-matt rouge pourpre, satiné mat purperrood, zijdemat púrpura, mate seda vermelho púrpura, fosco sedoso rosso porpora, opaco seta purpurrood, sidenmatt purpurpuranainen, silkinihimmä purpurrad, silkematt purpurrad, silkematt пурпурно-красный, шелк.-матовый purpurowy, jedwabisto-matowy πορφυρό κόκκινο, μεταξωτό ματ erguvan kırmızı, ipek mat purpuroně červená, hedvábně mat. biborvörös, selyemmatt temno rdeča, svila mat	braun, seidenmatt 381 brown, silky-matt brun, satiné mat bruin, zijdemat marrón, mate seda castanho, fosco sedoso marrone, opaco seta brun, sidenmatt ruskea, silkinihimmä brun, silkematt brun, silkematt коричневый, шелковисто-матовый brązowy, jedwabisto-matowy καφέ, μεταξωτό ματ kahverengi, ipek mat hnědá, hedvábně matná barna, selyemmatt rjava, svila mat	

M	N	1.	O	2.	P	Q
gold, metallic 94 gold, metallic oro, métallique goud, metallic oro, metalizado ouro, metálico oro, metalico gold, metallic gold, metallikiilto gold, metallak gold, metallic золотой, металл złoto, metaliczny χρυσάφι, μεταλλικό altın, metalik zlatá, metaliza arany, metall zlatna, metalik	feuerrot, glänzend 31 fiery red, gloss rouge feu, brillant rood helder, glansend rojo fuego, brillante vermelho vivo, brilhante rosso fuoco, lucente eldröd, blank tulipunainen, kiiltävä ildröd, skinnende ildröd, blank огненно-красный, блестящий szerepony ognisty, błyszczący κόκκινο φωτός, γυαλιστερό ateş kırmızı, parlak ohnivě červená, lesklá tűzpiros, fényes ogeni rdeča, bleskajoča	silber, metallic 90 silver, metallic argent, métallique zilver, metallic plata, metalizado plata, metálico argento, metalico silver, metallic hopea, metallikiilto salv, metallak salv, metallic серебристый, металл srebro, metaliczny οσημί, μεταλλικό gümüş, metalik stříbrná, metaliza ezüst, metall srebrna, metalik	orange, klar 730 orange, clear orange, clair oranje, helder naranja, claro laranja, claro arancione, chiaro orange, klar oranssi, kirkas orange orange orange оранжевый pomarańczowy πορτοκαλί, διαυγές kirmizi, şeffaf červená, círá piros, áttetsző pomarandžasta, jasna	rot, klar 731 red, clear rouge, clair rood, helder rojo, claro vermelho, claro rosso, chiaro röd, klar punainen, kirkas röd röd красный szerepony κόκκινο, διαυγές kirmizi, şeffaf červená, círá piros, áttetsző rdeča, jasna	orange, klar 730 orange, clear orange, clair oranje, helder naranja, claro laranja, claro arancione, chiaro orange, klar oranssi, kirkas orange orange оранжевый pomarańczowy πορτοκαλί, διαυγές kirmizi, şeffaf červená, círá piros, áttetsző pomarandžasta, jasna	

Dieser Bausatz wurde in mehrfachen Qualitäts- und Gewichtskontrollen auf Vollständigkeit überprüft. Reklamationen können nur bearbeitet werden, wenn die Bauanleitung, das aus der Kartonage herausgeschnittene EAN-Strichcode-Feld und der Kassenbon eingeschickt werden. Bitte haben Sie Verständnis dafür, dass wir nur Gewährleistung bei aktuellen Artikeln übernehmen können, die im Zeitraum der letzten 24 Monate erworben worden sind. Unfrei eingesandte Reklamationssendungen werden von uns nicht angenommen! Einzelteile für Umbauten können gegen Vorkasse erworben werden*. Unsere Adresse: Revell GmbH & Co. KG, Abteilung X, Henschelstr. 20-30, 32257 Bünde. Dieser Directservice gilt für die Länder: Deutschland, Benelux, Österreich, Frankreich, Großbritannien. Reklamationen aus den übrigen Ländern werden über die jeweiligen Distributeure abgewickelt. Bitte kontaktieren Sie Ihren Händler.

This Model Kit has been subject to extensive quality and weight checks during the manufacturing process to ensure it leaves our warehouse in perfect condition. We are only able to process applications for missing parts if the following procedure is followed. In all cases the following will be required before we are able to process any request: Original receipt (proof of purchase) original instruction sheets (will be returned) and the bar code cut out of the box. We may not be able to process requests for products that have been discontinued for more than 24 months. Products that are returned directly to us without prior authorisation by a company representative will not be accepted and returned to sender. Replacement parts for conversion or spares will continue to be available however they will incur a handling charge. Please write to: Department X Revell GmbH & Co. KG, Henschelstr 20-30, 32257 Bünde.

This direct service is only available in the following markets: Germany, Benelux, Austria, France & Great Britain, Revell GmbH & Co. KG, Boston Houso, 64-66 Queensway, Hemel Hempstead, Herts, HP2 5HA, Great Britain. For all other markets please contact your local dealer or distributor directly.

Afin de vous donner entière satisfaction et pour nous assurer que tous les éléments nécessaires au montage de votre maquette sont présents dans la boîte, cet article a subi dans son intégralité divers contrôles qualitatifs ainsi que des contrôles de poids.

Si toutefois vous devez nous faire part de certaines réclamations, nous vous prions de bien vouloir vous adresser à votre revendeur habituel, muni de la notice de montage, du code EAN découpé sur la boîte, ainsi que de votre ticket de caisse. Le SAV ne sera assuré que pour les articles ayant été acquis depuis moins de 24 mois. Les pièces de rechange utilisées pour la transformation de maquettes pourront être obtenues en pré-paiement. Dans le cas où vous n'obtiendriez pas satisfaction, vous pouvez vous adresser directement à notre service SAV à l'adresse suivante: REVELL GmbH & Co. KG, Abteilung X, Henschelstraße 20-30, D-32257 Bünde ou Revell GmbH & Co. KG, 14 B, rue du Chapeau Rouge, F-21000 Dijon, France. Pour tous les autres marchés, merci de prendre contact avec votre détaillant ou distributeur.

Deze bouwdoos werd verscheidene malen volledig gecontroleerd op kwaliteit en gewicht. Klachten kunnen slechts in behandeling worden genomen indien de bouwhandleiding, de uit de doos geknipte EAN - streepjescode en de kassabon zijn meegezonden. Wij vragen om uw begrip dat wij alleen garantie kunnen geven voor huidige artikelen die binnen een periode van de laatste 24 maanden zijn gekocht. Onvolledig ingezonden klachten kunnen niet in behandeling worden genomen. Onderdelen voor ombouw kunnen tegen vooruitbetaling gekocht worden.

Ons adres is: Revell GmbH & Co. KG, Afdeling X, Henschelstrasse 20-30, 32257 Bünde, Duitsland. Deze directe service geldt alleen voor de volgende landen: Duitsland, Benelux, Oostenrijk, Frankrijk, Groot-Brittannië. Klachten afkomstig uit overige landen worden via de eventuele lokale vertegenwoordigers van Revell afgewikkeld. Wij verzoeken u contact op te nemen met uw winkelier.

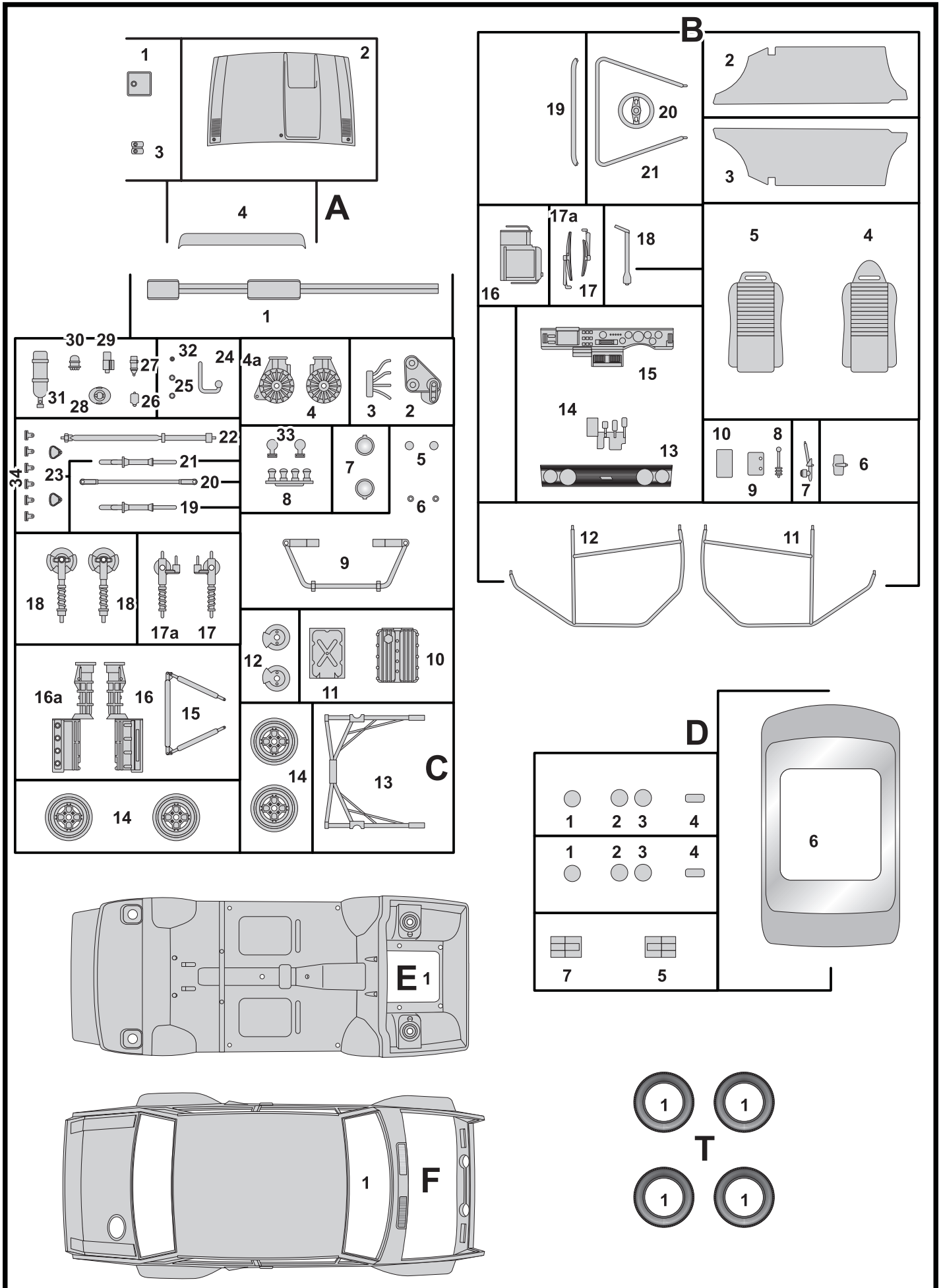

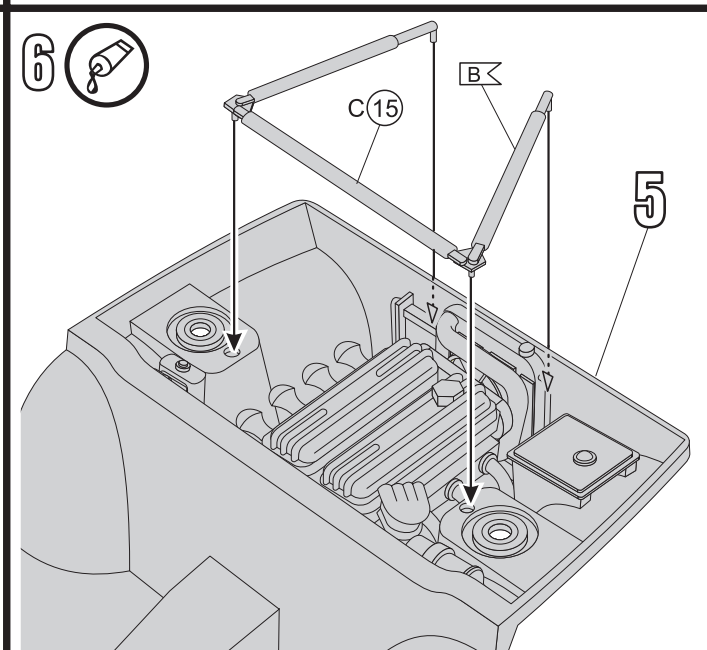
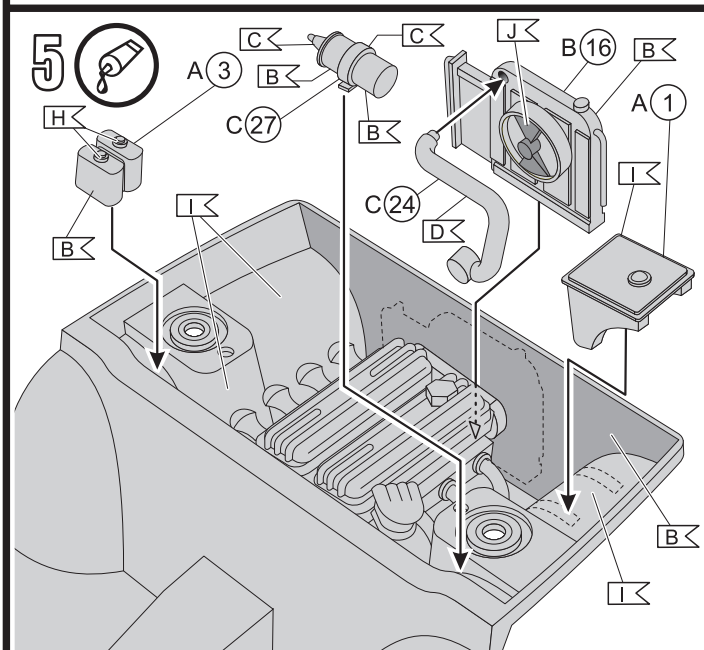
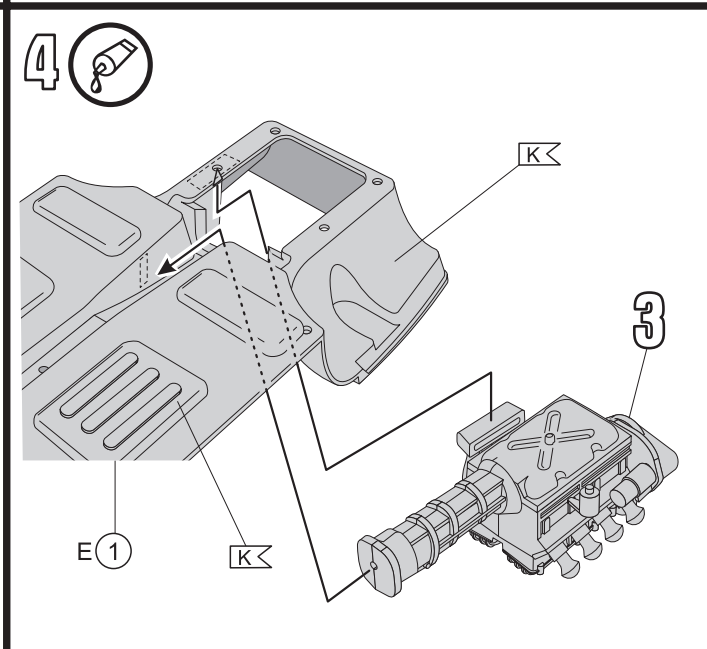
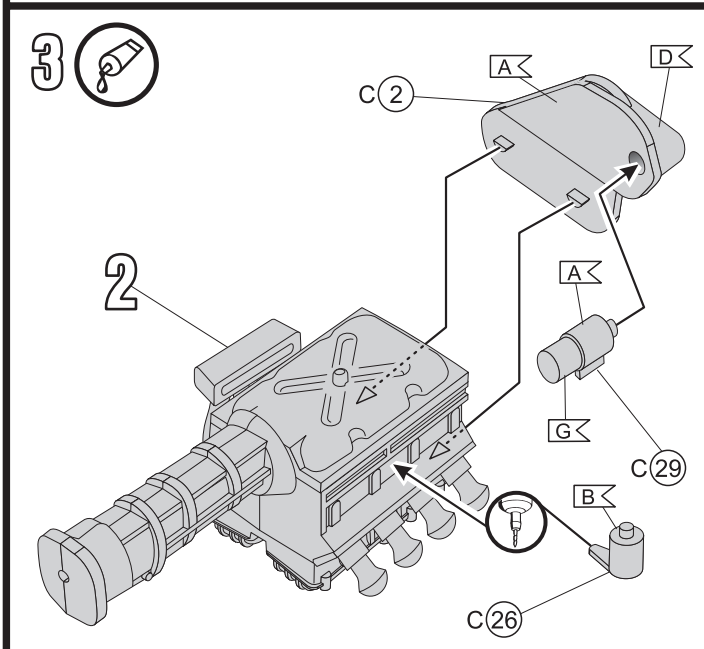
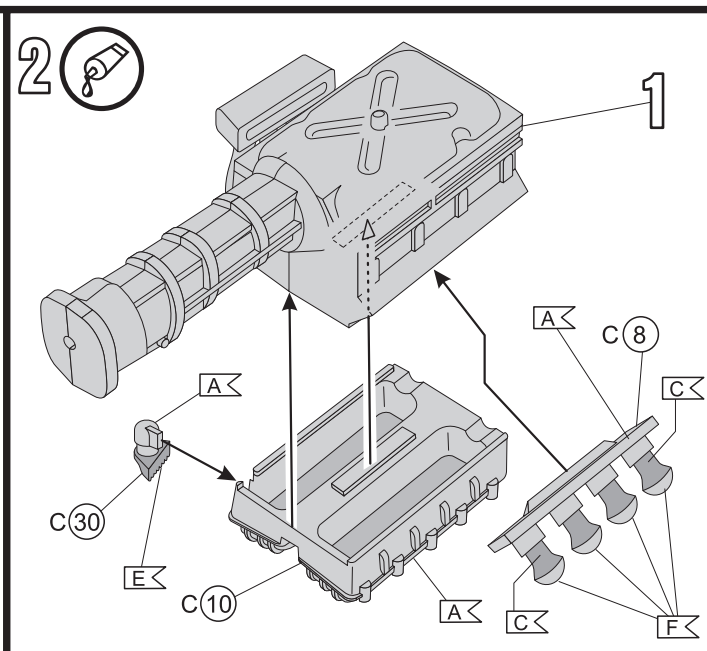
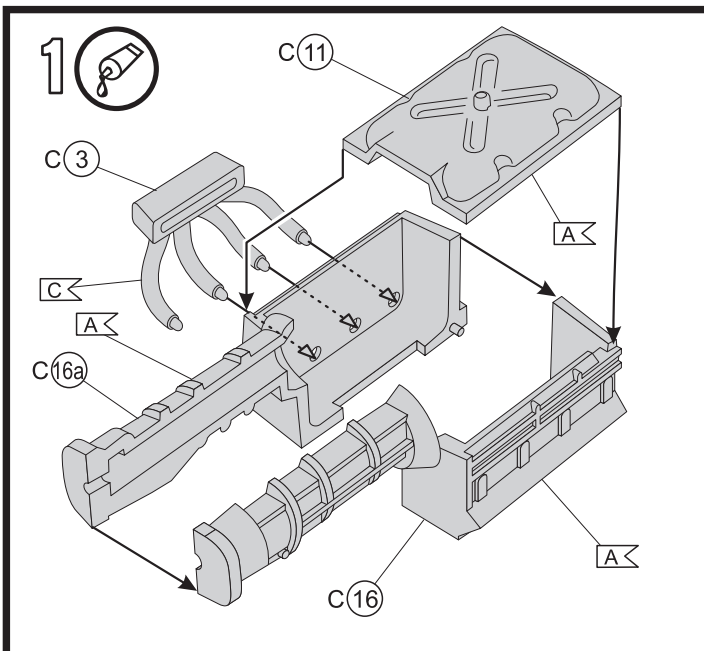

7 

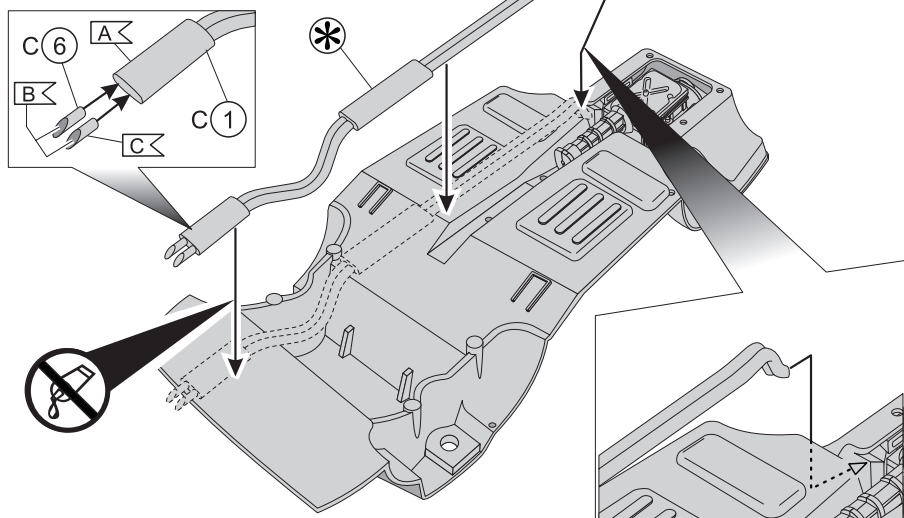

8 

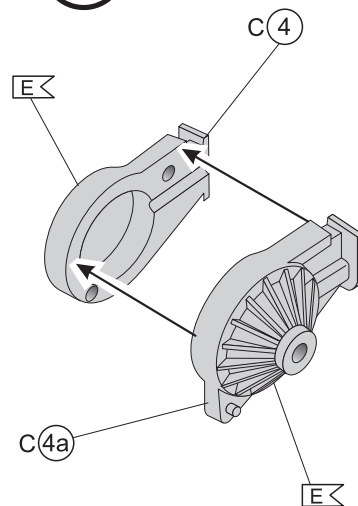

9 

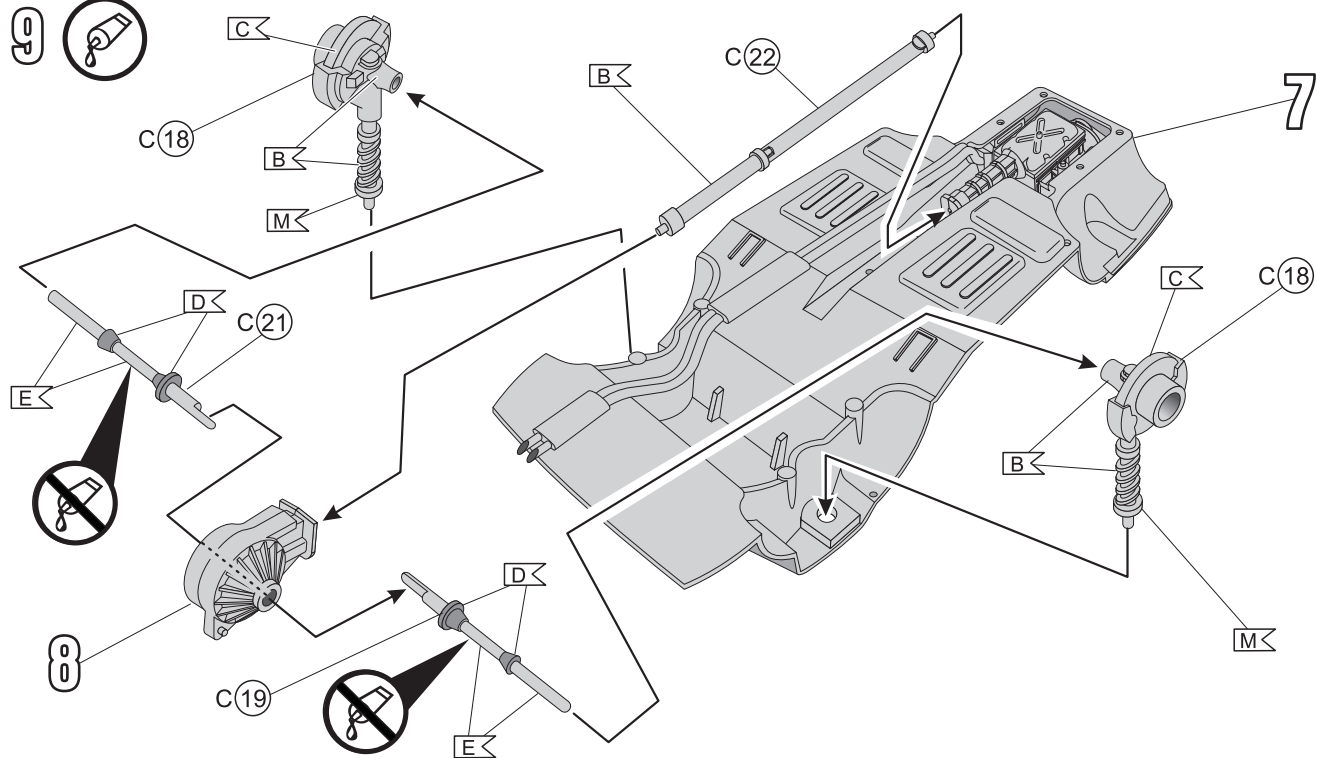

10 

4x

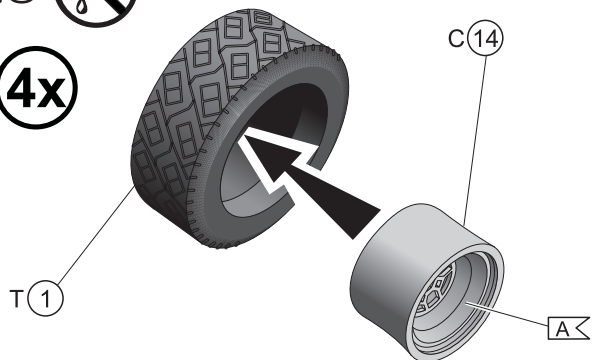

11 

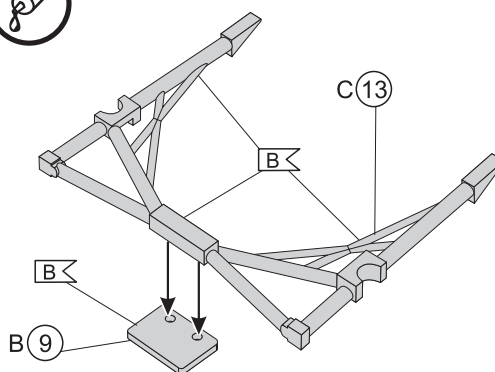

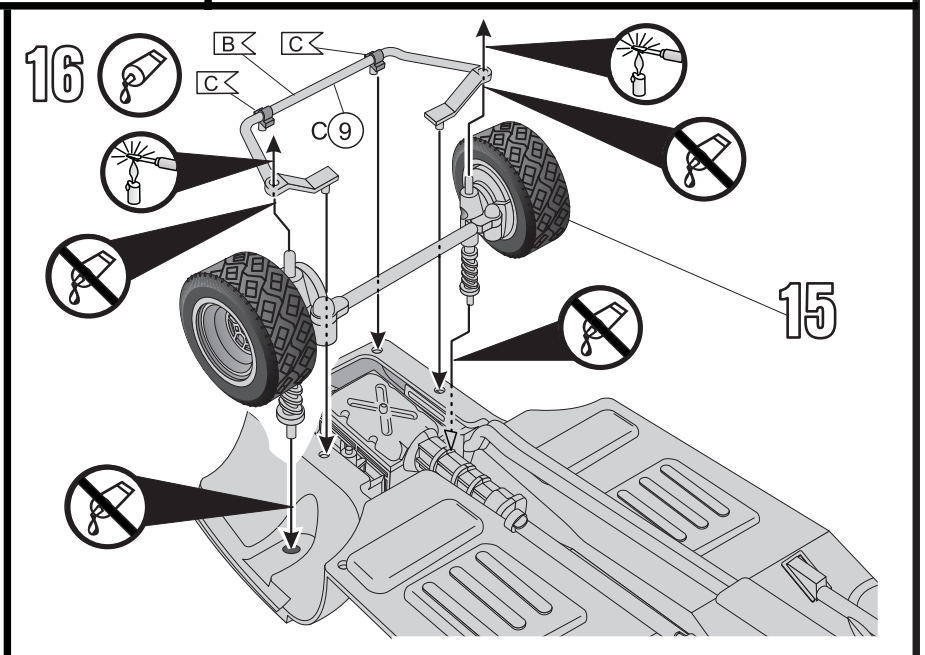
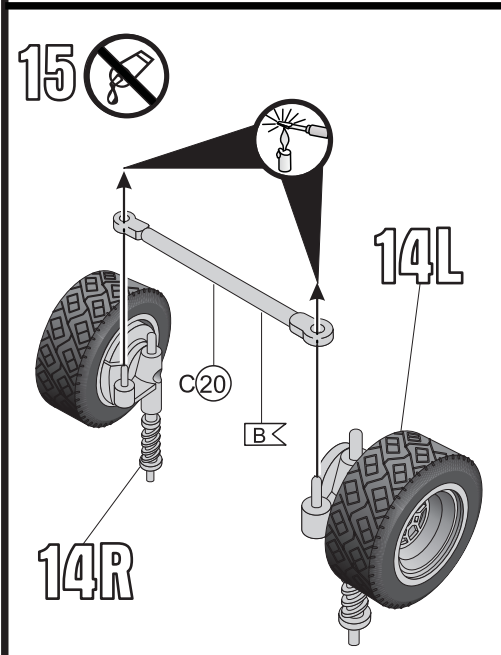
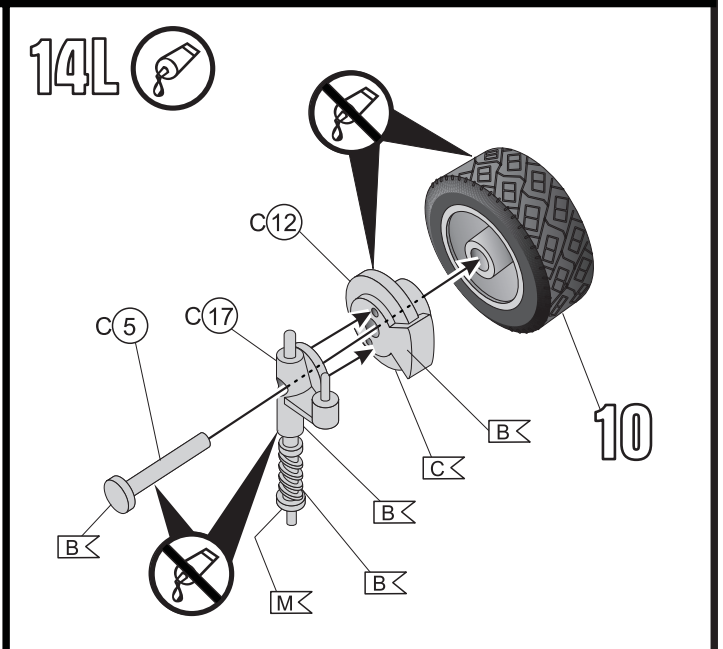
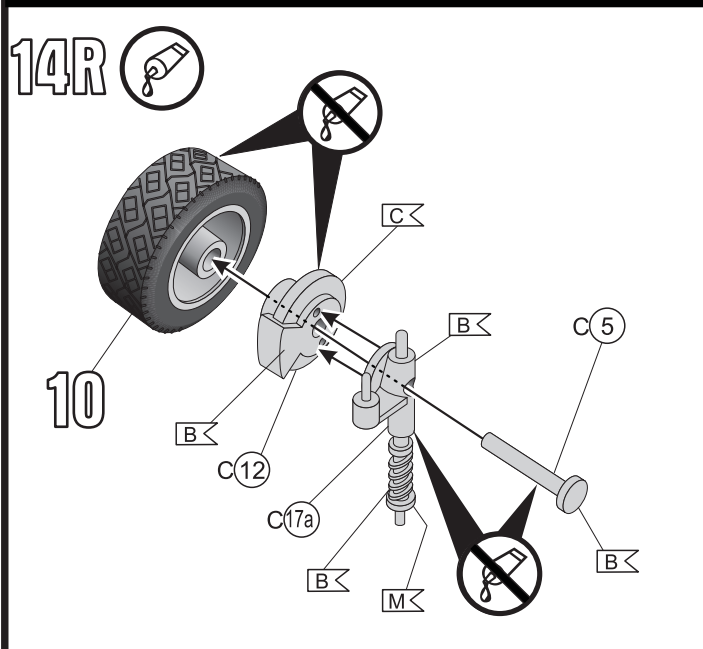
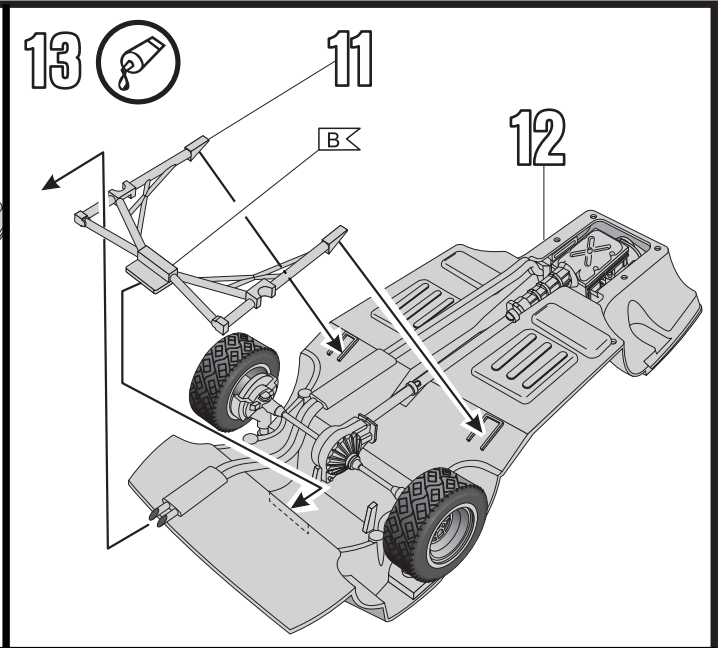
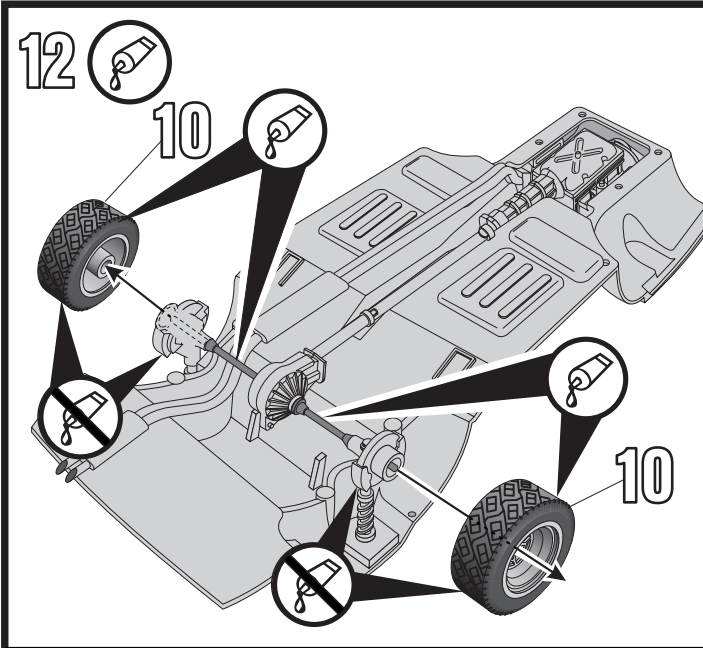

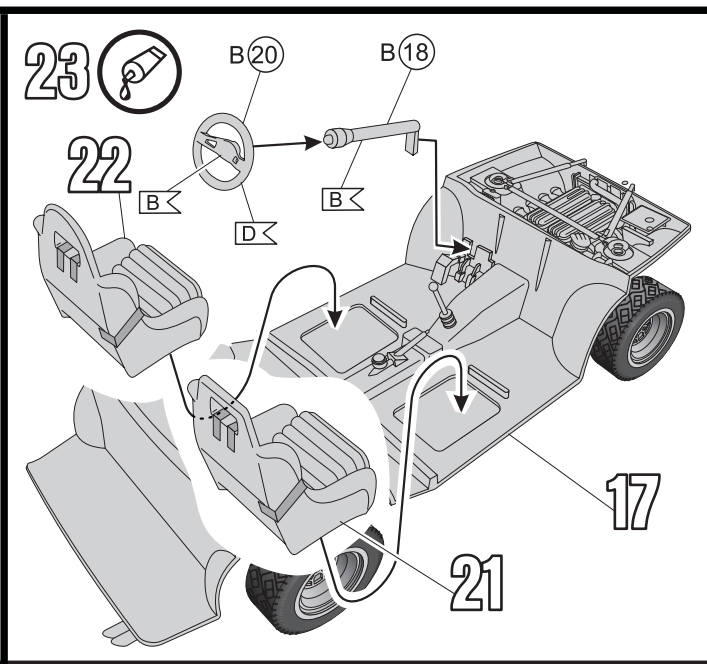
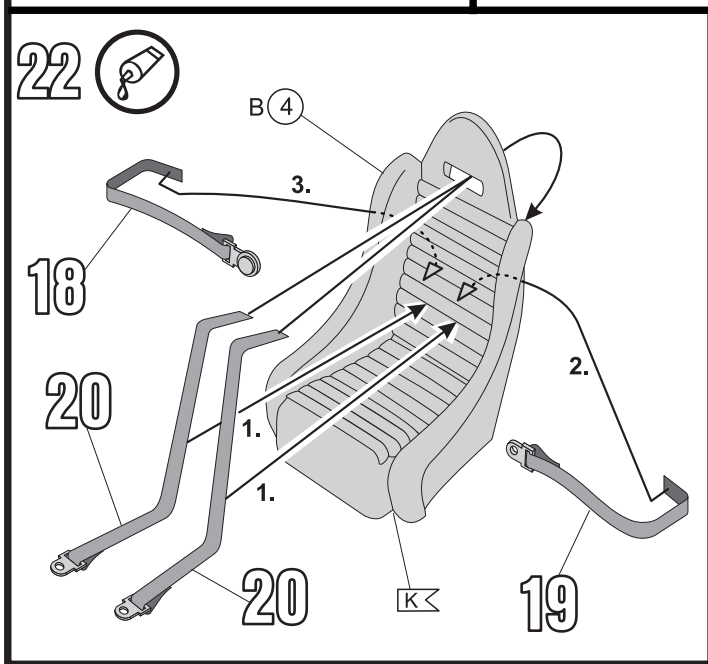
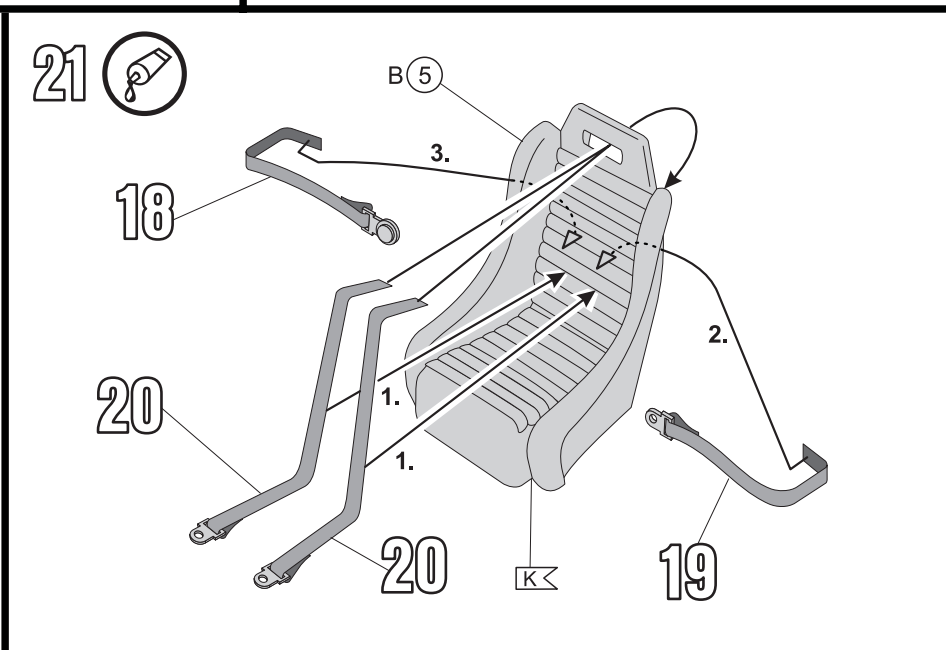
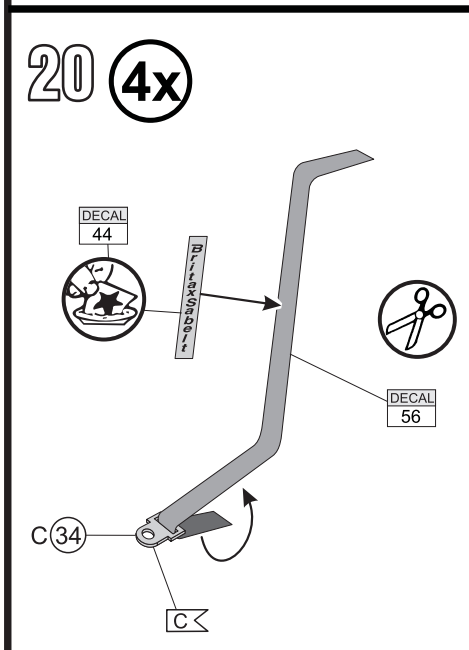
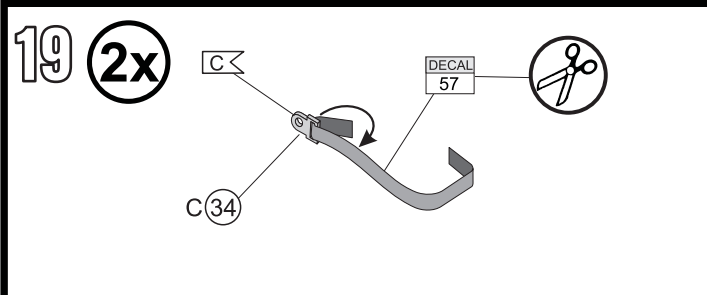
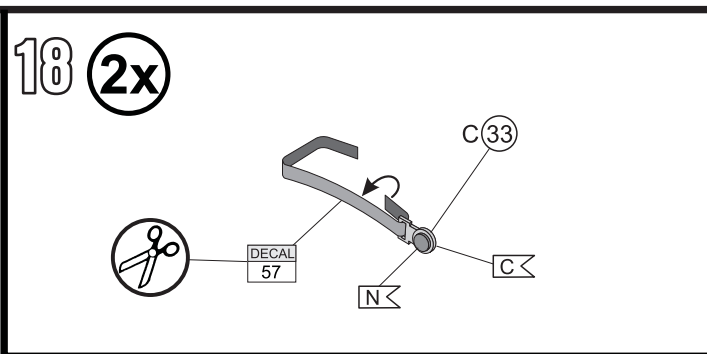
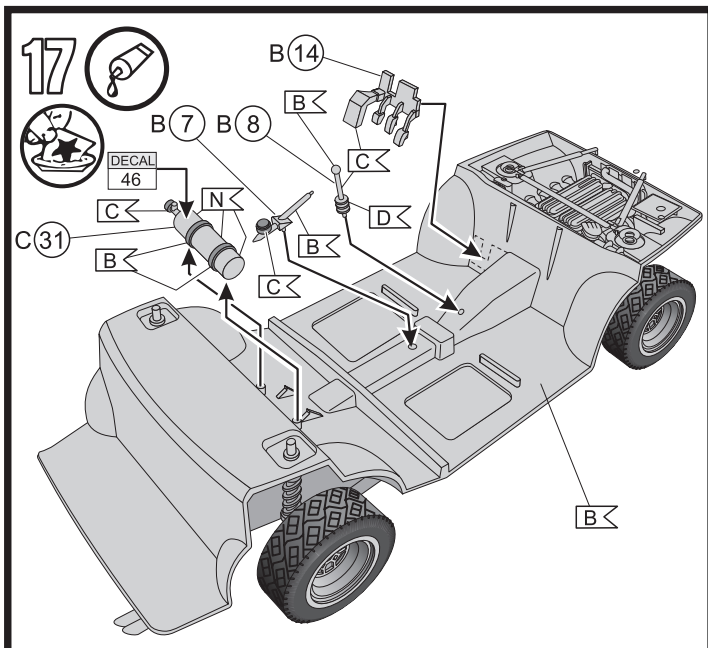

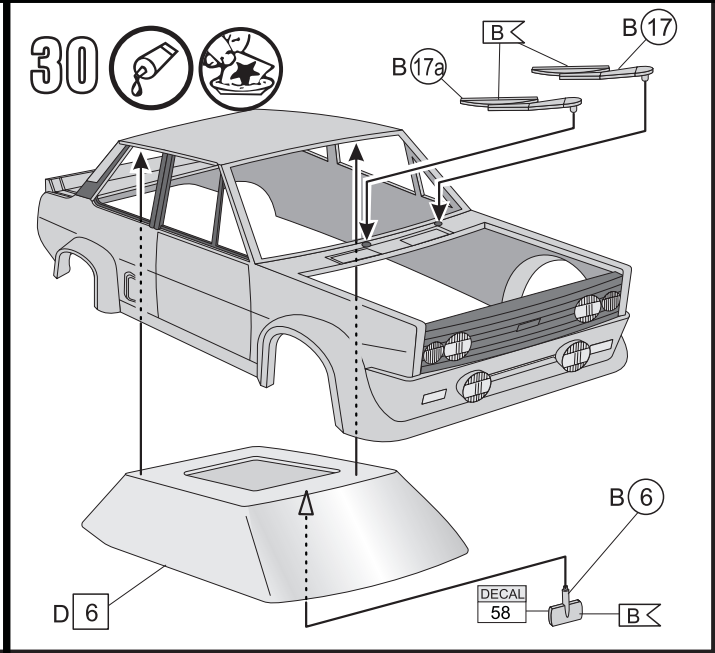
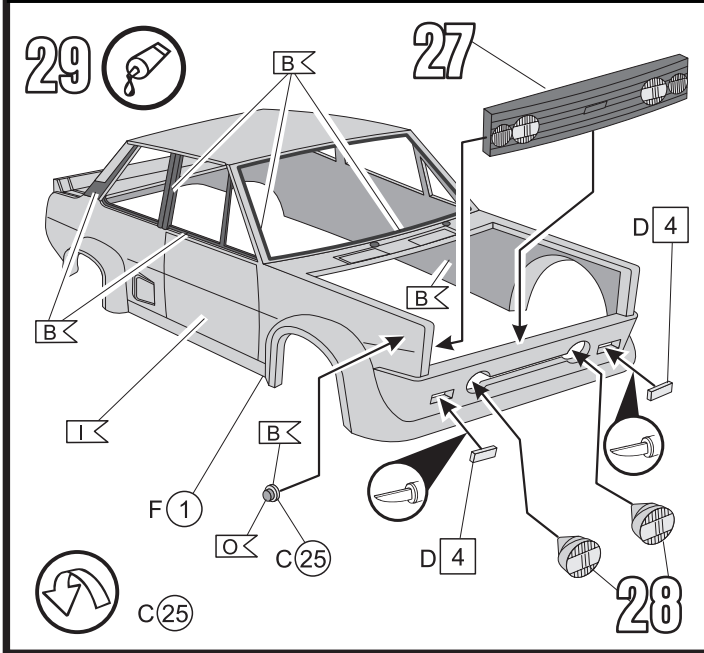
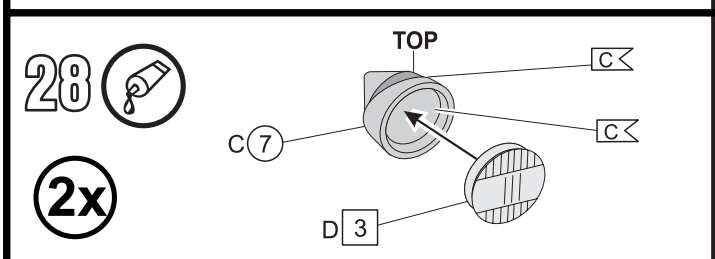
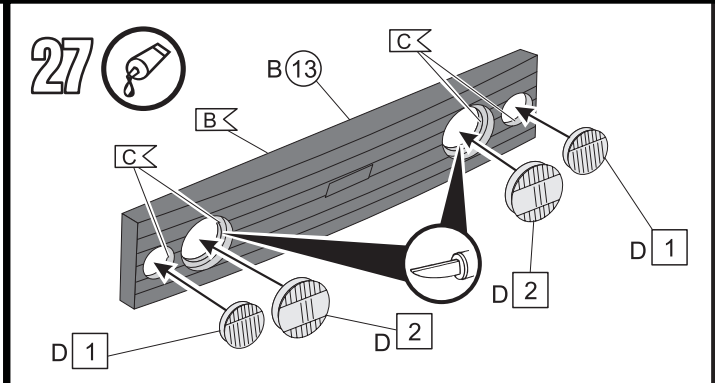
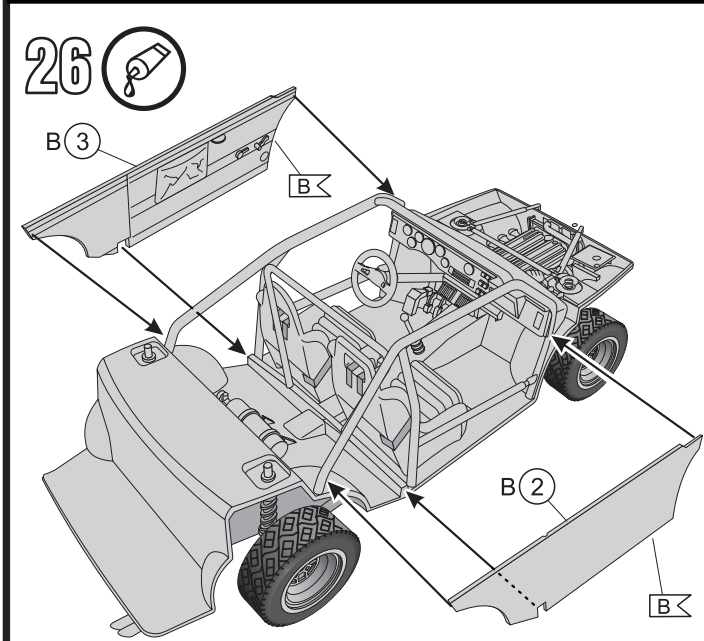
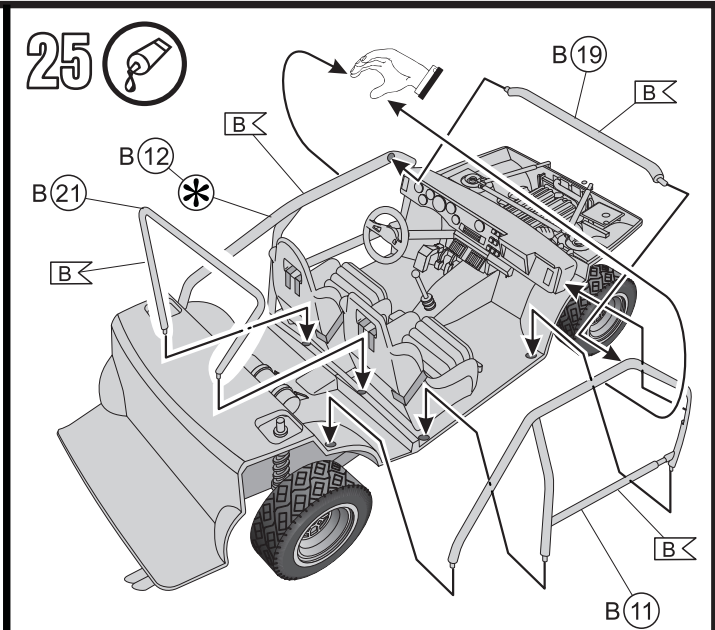
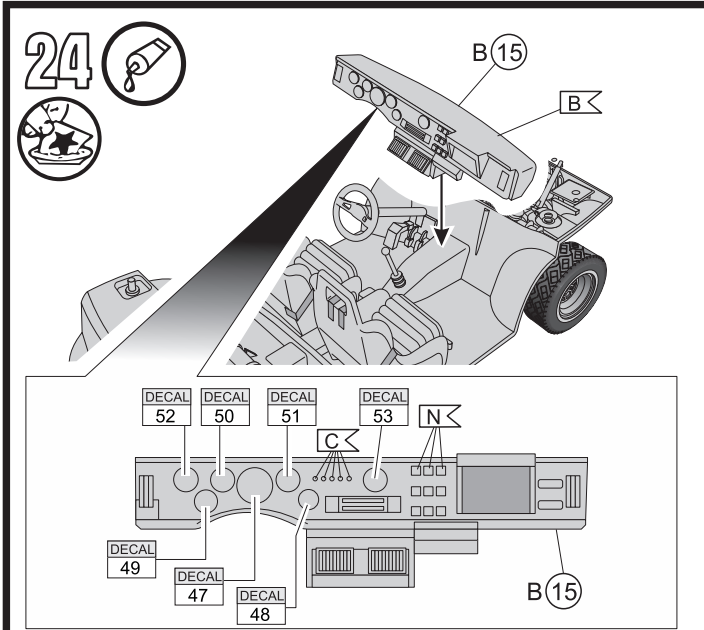

31 

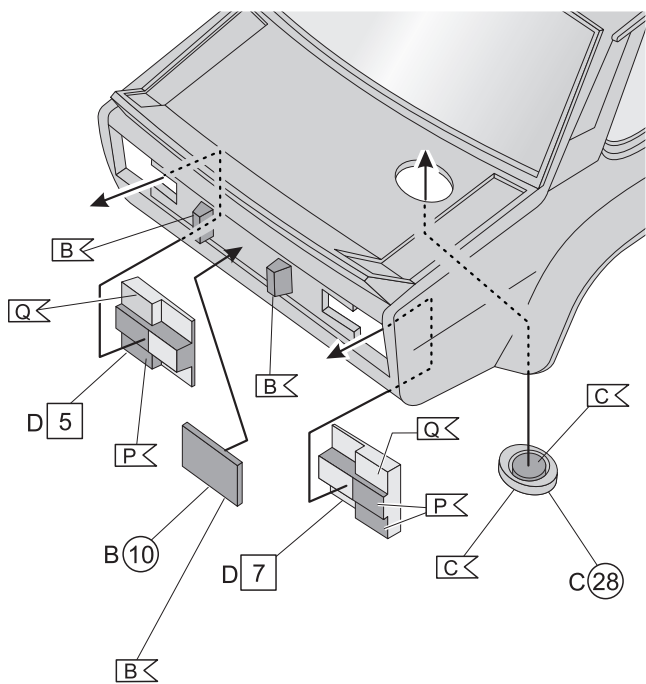

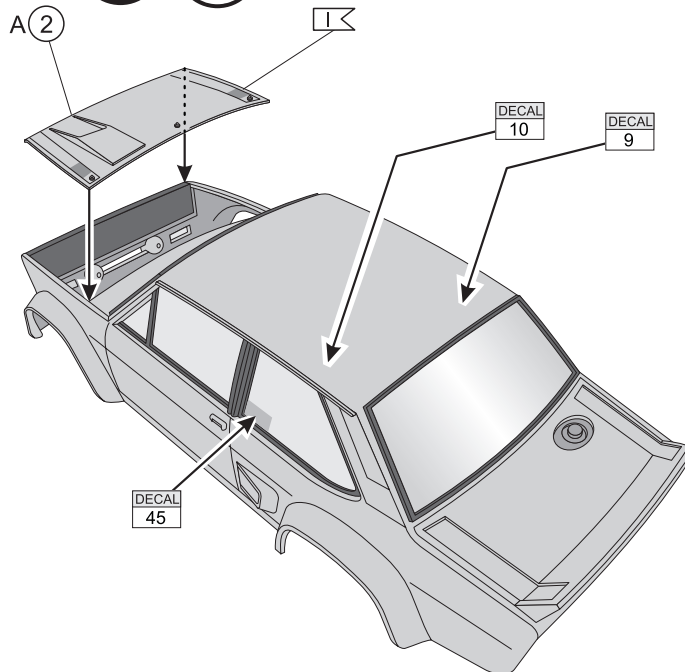

32  

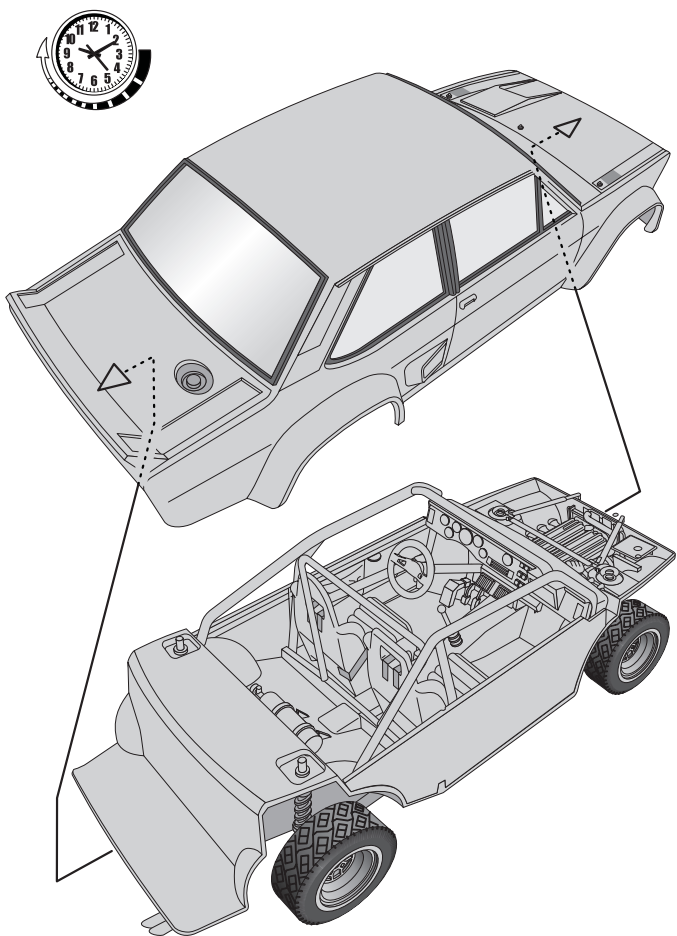

33  



34  

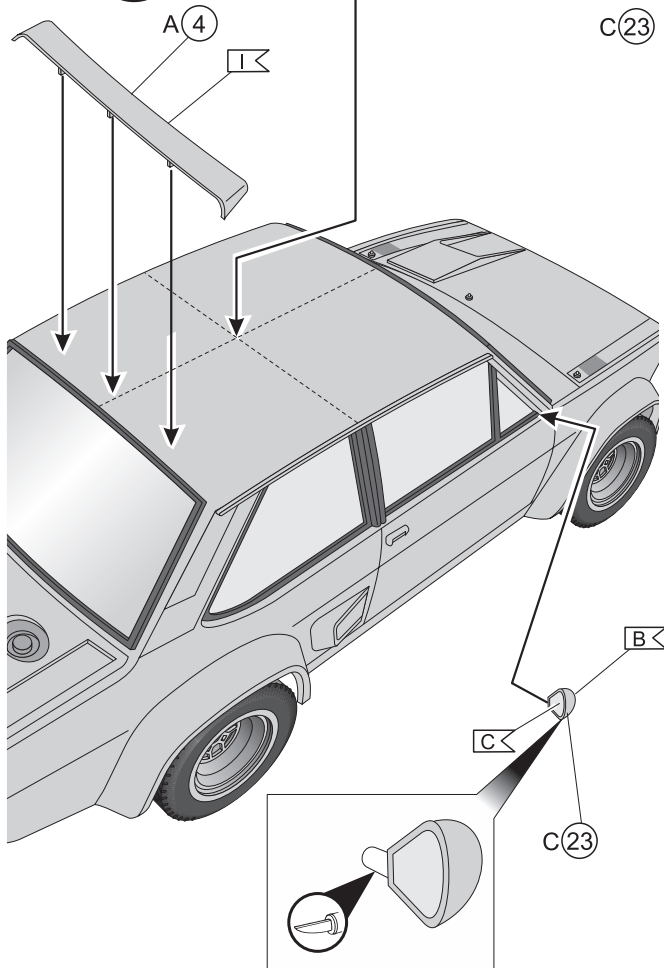

35 

