

# Ernst Udet's aircraft

LIMITED EDITION



# DU DOCH NICHT!!

1/48

Albatros D.V / D.Va  
Fokker Dr.I  
Fokker D.VII (OAW)

11137\_NAV1

eduard

# Ernst Udet – The leading surviving ace

Foreword by Jörn LECKSCHEID

Ernst Udet was born in Frankfurt am Main on Sunday, April 26th, 1896 as the son of Adolf and Paula Udet (née Krüger). The family moved to Munich when Ernst was still a little boy, and he would grow up in the capitol of Bavaria.

Erni, as he was known to his friends, was a bit of a tomboy, and while he was not exactly the most ardent student, he was described as being a bright child who learns quickly – but forgets just as easily!

He very much enjoyed playing outside with his friends, and had developed remarkable skills with his self-made slingshot. Needless to say that these childhood marksmanship skills would serve him well a few years later.

He developed an interest in aviation at an early age, and, together with a group of friends, founded the „Aero Club München“ some time between the age of ten to thirteen.

Beginning in 1909, the Oberwiesenfeld in Munich was used as an airfield, and Gustav Otto, the son of the inventor of the Otto engine, set up his company „Gustav Otto Flugmaschinenwerke“ near that location. Erni and his friends would visit the area frequently to watch the aeroplanes and balloons, but his dream of learning to fly would not be fulfilled while he was still attending school.

His performance at school did not improve much over the years, but he was very skilled at drawing, and when he did pass his exams in 1913, his delighted father presented him with a motorbike.

At the outbreak of the war, Udet immediately volunteered, but was turned down since he was not even 1,60 metres tall. But he still found a way to make it to the front about two weeks later by taking a clever detour.

The „ADAC“, the German Automobile Association, had been looking for volunteers, who owned a motorcycle and were willing to take it along to the front. They did not care about the height of a volunteer, and so Erni and his motorbike left Munich on the evening of August 18th, 1914.

His career as a motorbike messenger would be rather short, since when he learned, that he could get into military aviation quicker if he possessed a privately acquired pilots licence, he took up flying lessons at the aforementioned Gustav Otto Werke at the end of 1914 and received his civilian pilot licence in April 1915.

From then on, his pilot career progressed like that of many other men. He served with various two-seater units (Fliegerabteilungen), one of these was re-formed into Kampfeinsitzer-Kommando (KEK) Habsheim, and with that unit he finally scored his first aerial victory in the afternoon of March 18th, 1916, shooting down a french Farman F 40, one of 22 planes that were heading to bomb Mülhausen on that day.

By the autumn of 1916 another re-organization in the Fliegertruppe began to take shape, and the first Jagdstaffeln (Jastas) were formed. KEK Habsheim mutated into Jasta 15, and Udet was formally transferred to that unit on October 8th, 1916 – without actually moving somewhere else, of course!

Four days later he would score his second victory, and on January 22nd, 1917 he was promoted to the rank of Leutnant der Reserve. Not long before this date, Jasta 15 had received the new Albatros D.III fighter, and Udet would score all of his 13 victories in 1917 in the cockpit of this type and its later variants, the D.V and D.Va.

On June 19th, 1917, Erni was posted to Jasta 37, and he would take over command of that unit on November 7th of that year.

In late January and early February Udet attended the First Fighter Competition in Berlin Adlershof, where prototypes of the latest German fighter aircraft were evaluated and compared. Only the most experienced and successful frontline pilots were present at this event.

Jasta 37 would move to the airfield of Le Cateau on March 15th, 1918, and as they were pitching their tents there, Manfred von Richthofen, who was then stationed not too far away with his Geschwader, paid them a visit, and M v R asked Udet about his current victory score.

„19 confirmed and one pending confirmation“ was the reply, and the Rittmeister responded „Then it’s time for you to join us now“.

That was too good an offer to refuse, Richthofens Geschwader had some of the best pilots and was always equipped with the most modern fighters. Udet arrived at Jasta 11 on March 18th, 1918. His stay at Jasta 11 was rather short though, but long enough to score three victories. He developed a severe ear infection, and von Richthofen personally ordered him to return home to recover. Udet left Jasta 11 for Munich on April 8th, and he received the notification that he had been awarded the „Orden Pour-le-Mérite“ the very next day!

He was still in Munich when the Rittmeister was killed just twelve days later. The ear infection needed one more month to get better, and he returned to the front on May 22nd, 1918, taking command of Jasta 4.

Here, he would initially fly a type that he had already used at Jasta 11, the Fokker Triplane. His new plane at Jasta 4 was in fact an old one, he took over Fokker Dr.I 586/17, formerly flown by the leading ace of Jasta 6, Lt. Hans Kirschstein.

This Triplane would also be flown for only a few short days, since the frontline carrier of the Fokker Dr.I with Jagdgeschwader von Richthofen was almost over.

On June 13th, 1918, as the last component unit of JG I, Jasta 4 converted to the new Fokker D.VII, at last. The other three Jastas of the Geschwader had received the new type several weeks earlier, and now Jasta 4 got it, too.

One of these newly delivered Fokker D.VIIs, which were actually licence-built by the Ostdeutsche Albatros Werke (O.A.W.) would soon be repainted into the iconic – but also somewhat mysterious – „Du doch nicht!!!“.

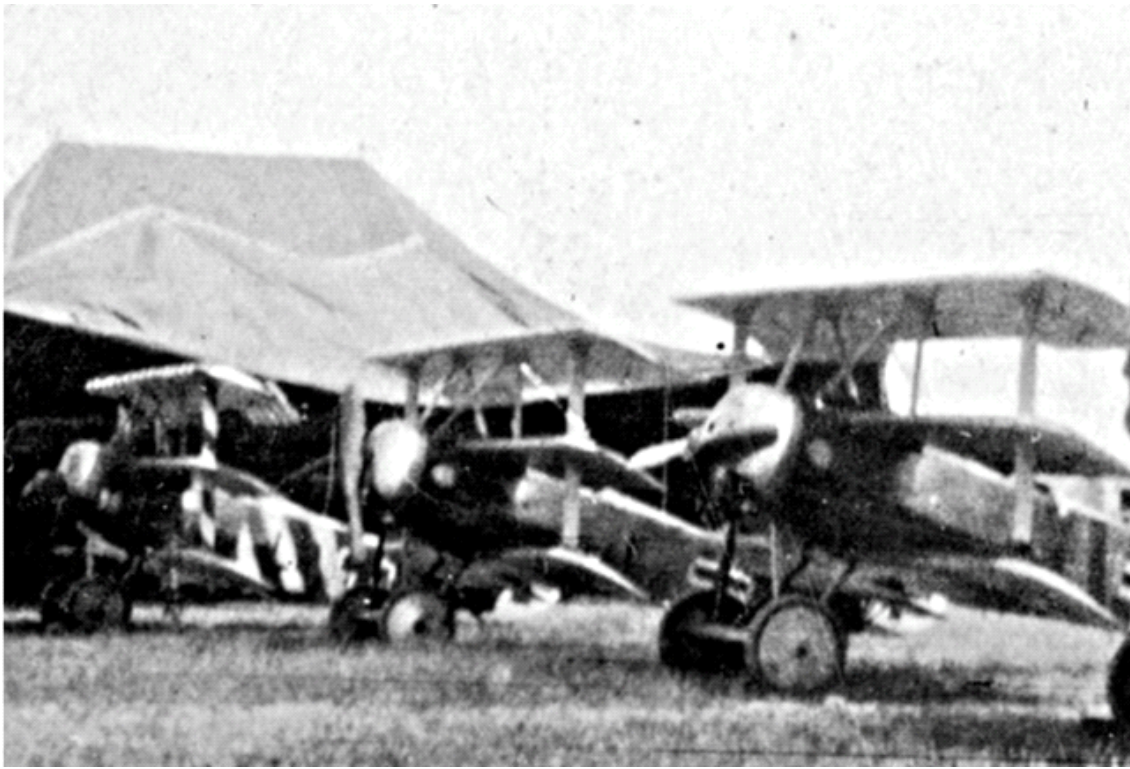

And this particular plane would also only enjoy a short life at the front. On June 29th, 1918, at 7:40 a.m., Udet attacked a French Breguet Br. 14 over Cutry. Thinking that he had disabled the observer with his first burst of machine gun fire, he decided to attack the plane from the side. But, the gunner decided to re-appear, opened fire and his bullets severed the control cables of Udet's beautiful new plane. The D.VII was falling out of control, and Erni barely managed to bail out and land just within the German lines.

He returned to Jasta 4 within a couple of hours, and was back in the cockpit of another Fokker D.VII later that same day – so much for the much-lamented shortage of airplanes in Fliegertruppe!

While flying with Jasta 4, Udet would be credited with 39 out of his total of 62 victories. Though he was officially commanding Jasta 4 up until the end of the war, he was actually only at the front for about 10 or 11 weeks during that period of five and a half months, making his record in terms of victories scored look even more impressive than it already is!

At the end of the war, Erni was the highest scoring German fighter pilot to survive the conflict, with 62 confirmed victories to his credit.

He got engaged to „Lo“ in December 1918, and the pair married in February the next year. Udet remained heavily involved in aviation right after the war, conducting demonstration flights for the public together with fellow ace Robert Ritter von Greim, the final commander of Jasta 34b, and writing articles for various magazines, both in Germany and abroad.

He founded various aviation companies in and around Munich in the 1920s, and sadly his relationship with „Lo“ already ended in 1922, and they divorced in 1923. Udet took the blame for the end of the marriage, and even apologized to Lo for his mishbehaviour in a short letter that still exists today.

Udet's flying adventures in the 1920s carried him to far away places, and in November 1924 newspapers in Germany reported that Udet was killed in a flying accident - which was, of course, not true.

In the 1930s, he was involved in several motion picture films that were all related to flying, he toured around the world in various airplanes and visited the USA, where he was re-united with at least one of his former adversaries, Walter Wannamaker, who was shot down by Udet in early July 1918.

Besides flying, he very much enjoyed the fun side of life, appreciated the company of attractive women as well as good food and alcohol, the two latter in ever increasing amounts.

His old comrade Hermann Göring talked him into taking up a very high position in the newly founded „Reichsluftfahrtministerium“ (RLM) but Udet himself found that in that job he was nothing but a flyer who was chained to a desk.

It turned out that he was not really the man best suited for this job, which he himself despised, and by 1941 he was blamed for many of the things that were going wrong in the RLM for the past couple of years.

On November 17th, 1941, Udet died in his home in Berlin. Internally, the cause of death was determined as suicide, but the Nazi leadership could hardly admit such a death of a famous celebrity to the general public. Instead, the propaganda reported that he was severely injured while testing a new secret weapon and succumbed to his injuries.

#### References:

- Ernst Udet – Kreuz wider Kockarde, 1918
- Ernst Udet – Mein Fliegerleben, 1935
- Alex Imrie – The Fokker Triplane, ISBN 1-85409-118-2, Arms & Armour Press, 1992
- Armand van Ishoven - Ernst Udet – Biographie eines großen Fliegers, 1977, ISBN 3-88199-316-9

ATTENTION



UPOZORNĚNÍ



ACHTUNG



ATTENTION



注意



Carefully read instruction sheet before assembling. When you use glue or paint, do not use near open flame and use in well ventilated room. Keep out of reach of small children. Children must not be allowed to suck any part, or pull vinyl bag over the head.



Před započatím stavby si pečlivě prostudujte stavební návod. Při používání barev a lepidel pracujte v dobře větrané místnosti. Lepidla ani barvy nepoužívejte v blízkosti otevřeného ohně. Model není určen malým dětem, mohlo by dojít k požití drobných dílů.

INSTRUCTION SIGNS \* INSTR. SYMBOLS \* INSTRUKTION SINNBILDEN \* SYMBOLES \* 記号の説明

OPTIONAL  
VOLBABEND  
OHNOUTSAND  
BROUSITOPEN HOLE  
VYVRTAT OTVORSYMETRICAL ASSEMBLY  
SYMETRICKÁ MONTÁŽREMOVE  
ODŘÍZNOUTREVERSE SIDE  
OTOČITAPPLY EDUARD MASK  
AND PAINT  
POUŽIT EDUARD MASK  
NABARVIT

PARTS



DÍLY



TEILE



PIÈCES



部品の

## PLASTIC PARTS

A&gt;

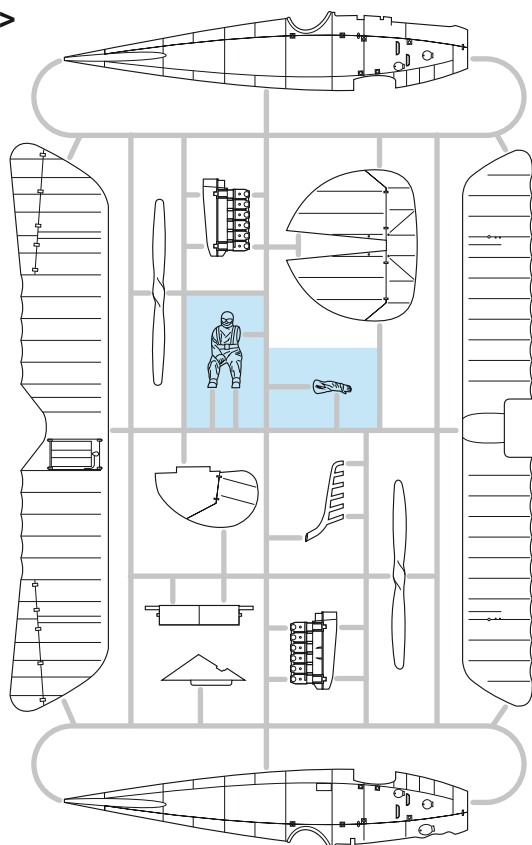

B&gt;

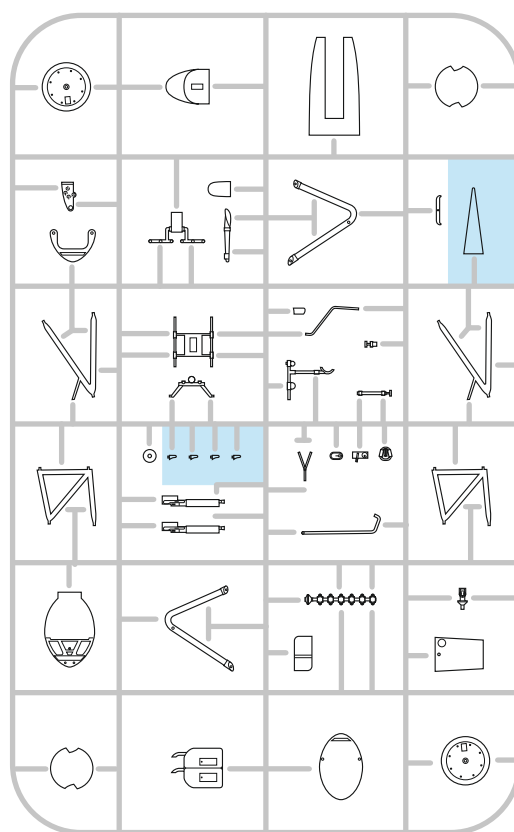

## PE - PHOTO ETCHED DETAIL PARTS

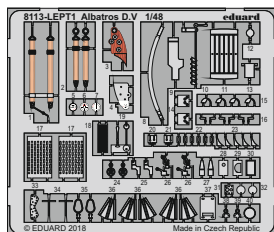
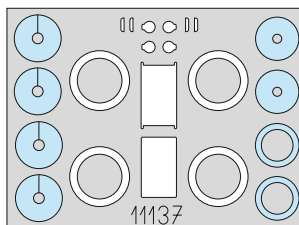
eduard  
MASK

## FILM

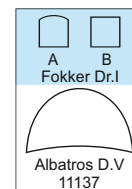

-Parts not for use. -Teile werden nicht verwendet. -Pièces à ne pas utiliser. -Tyto díly nepoužívejte při stavbě. -

COLOURS



BARVY



FARBEN



PEINTURE



色

GSI Creos (GUNZE)		MISSION MODELS	
AQUEOUS	Mr.COLOR	PAINTS	
H8	C8		SILVER
H11	C62	MMP-001	FLAT WHITE
H12	C33	MMP-047	FLAT BLACK
H37	C43		WOOD BROWN
H39	C67		PURPLE
H47	C41	MMP-012	RED BROWN
H51	C11	MMP-063	GRAY
H70	C60	MMP-056	LIGHT GULL GRAY

GSI Creos (GUNZE)		MISSION MODELS	
AQUEOUS	Mr.COLOR	PAINTS	
H330	C361	MMP-077	DARK GREEN
Mr.METAL COLOR		METALLICS	
MC214		MMM-001	DARK IRON
MC218		MMM-003	ALUMINIUM
MC219		MMM-009	BRASS
Mr.COLOR SUPER METALLIC		METALLICS	
SM201		MMC-001	SUPER FINE SILVER

# Albatros D.V/D.Va

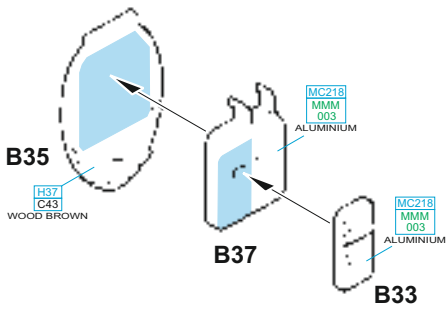

decal 55

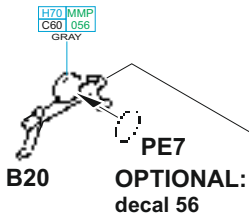
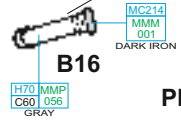
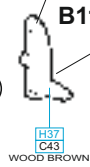

**PE7**  
OPTIONAL:  
decal 56

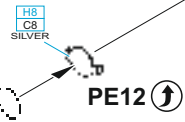

**PE5**  
OPTIONAL:  
decal 53

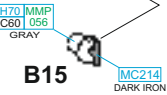

**B36**

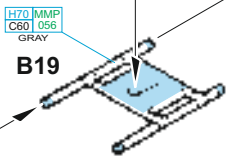

**PE6** OPTIONAL:  
decal 54

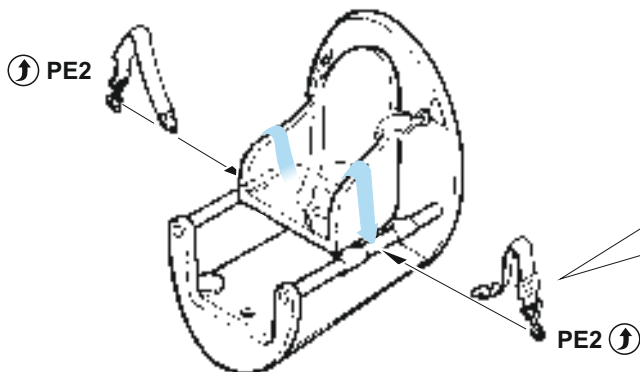
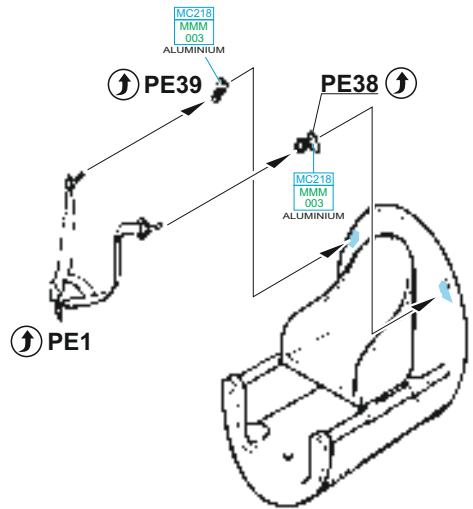
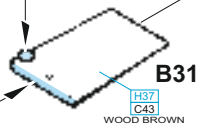
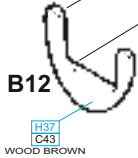

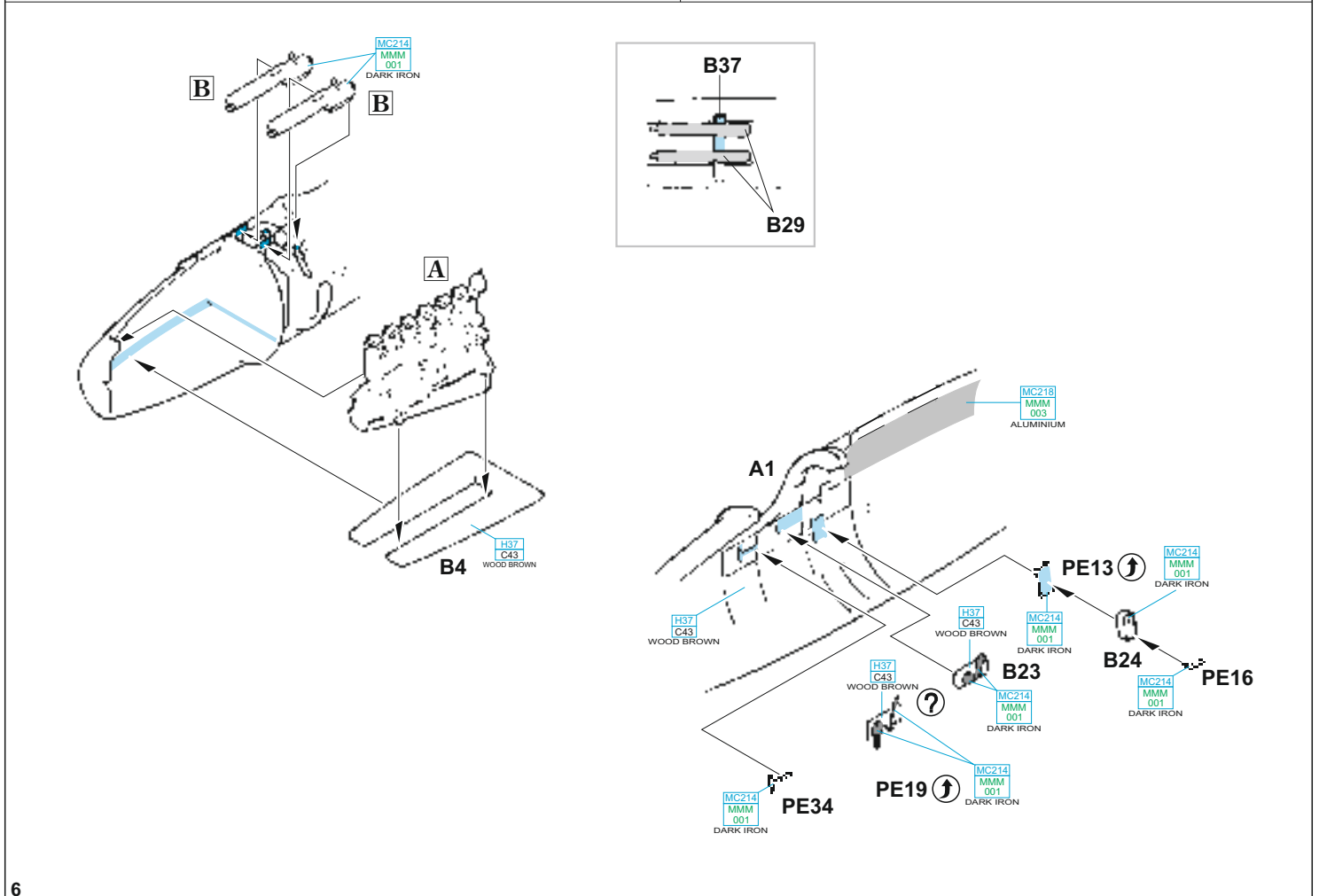
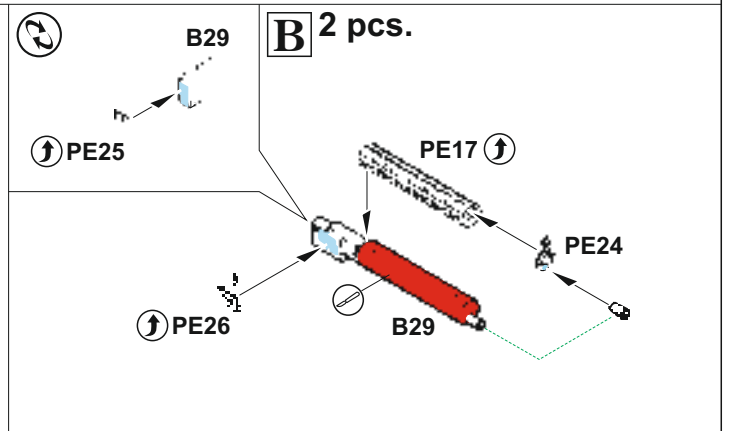
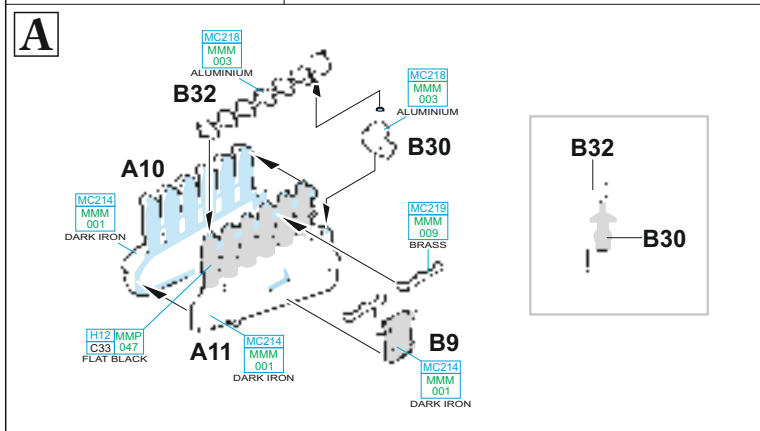
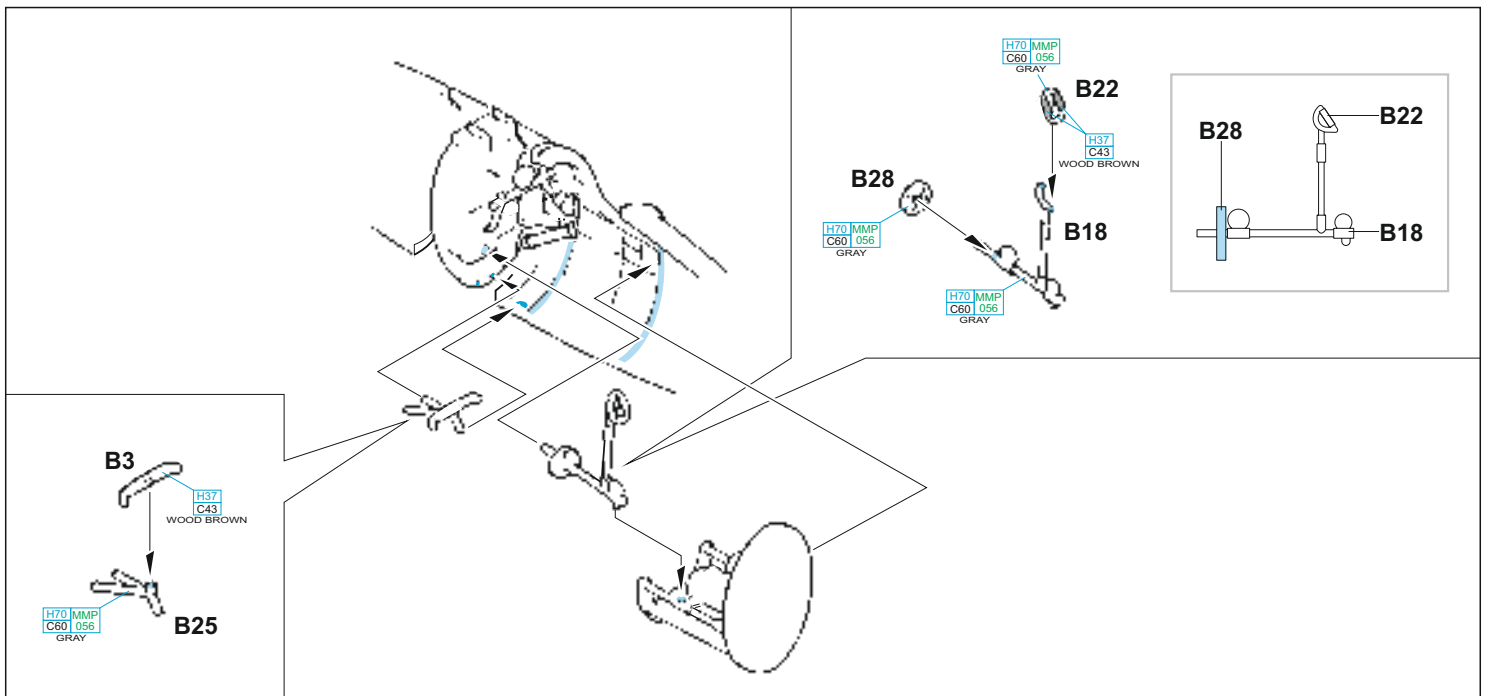

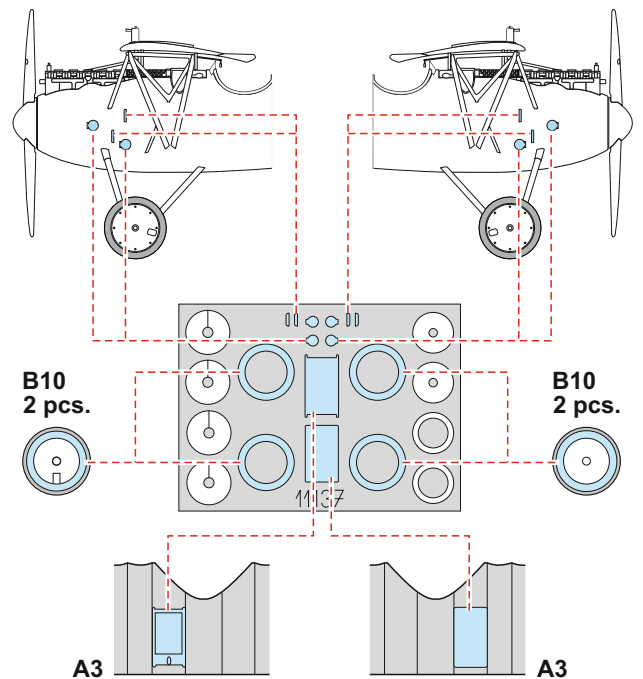
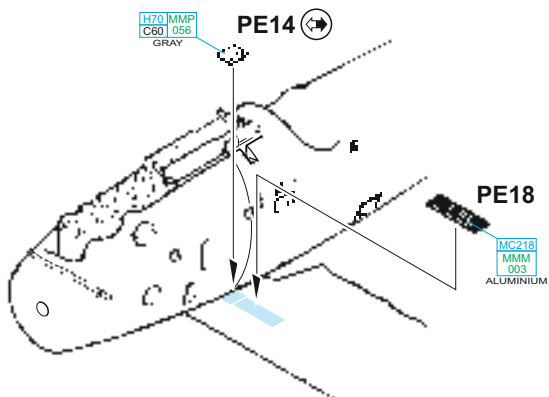
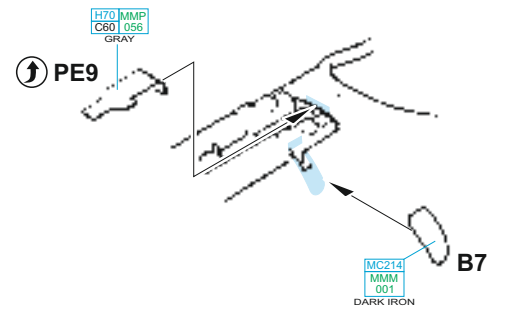
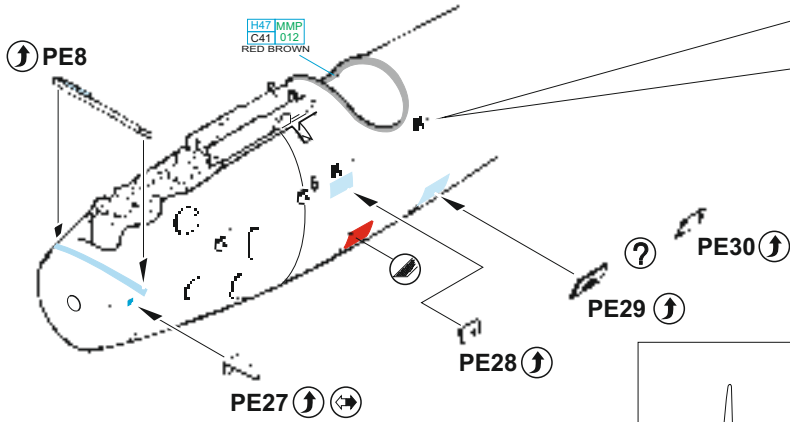
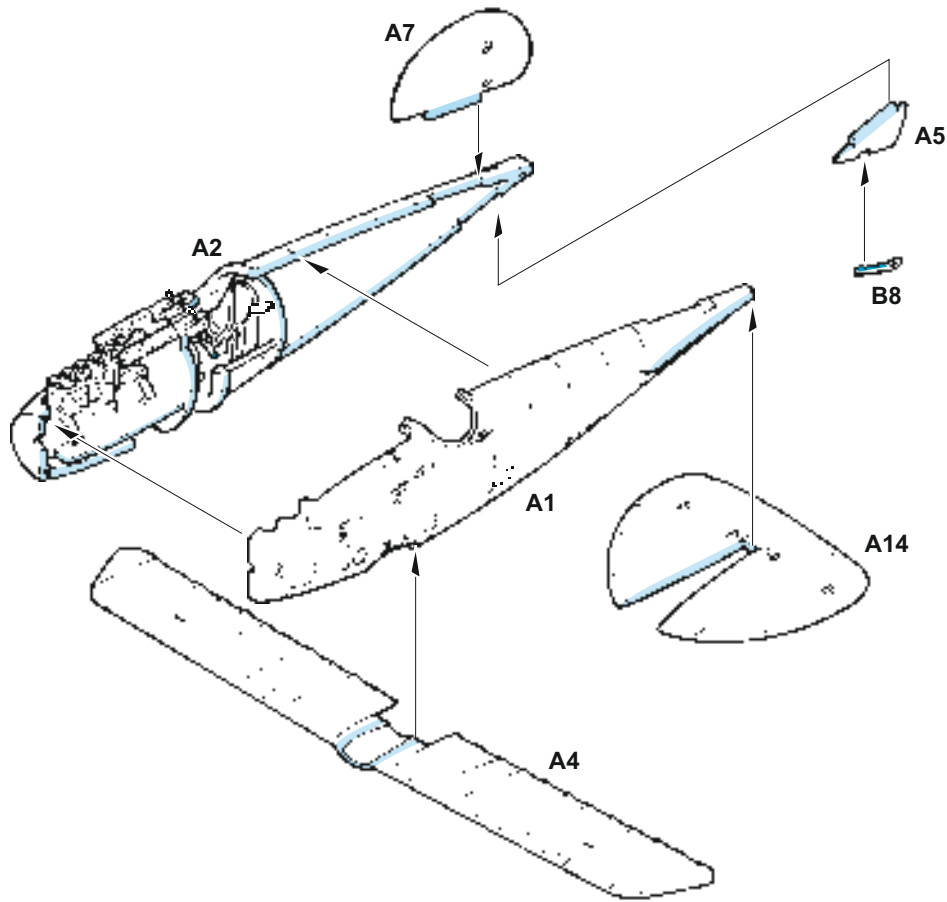

1 = CAMOUFLAGE COLOR - MARKING A  
 H70 MMP C80 056 GRAY - MARKINGS B, C

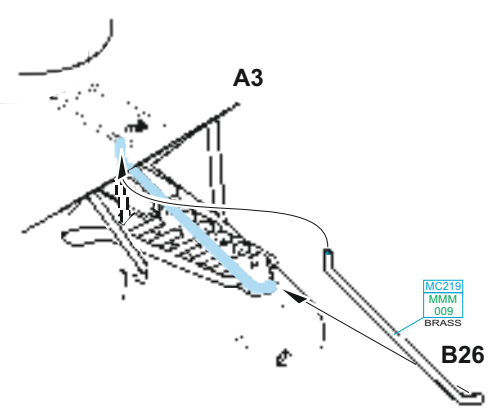
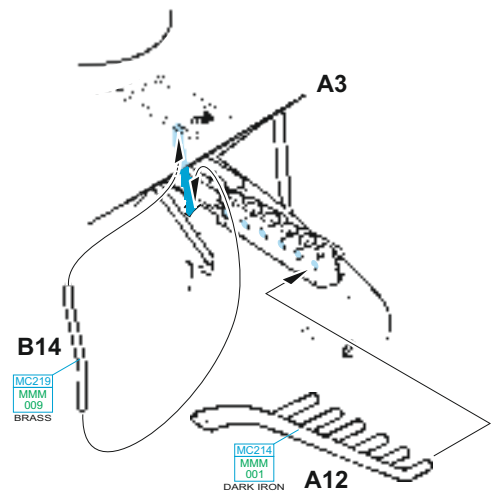
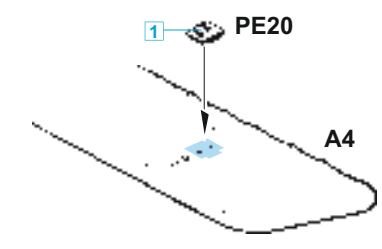
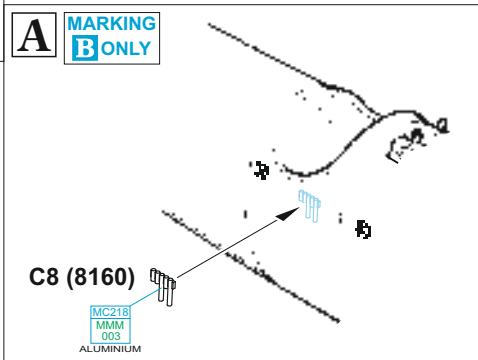
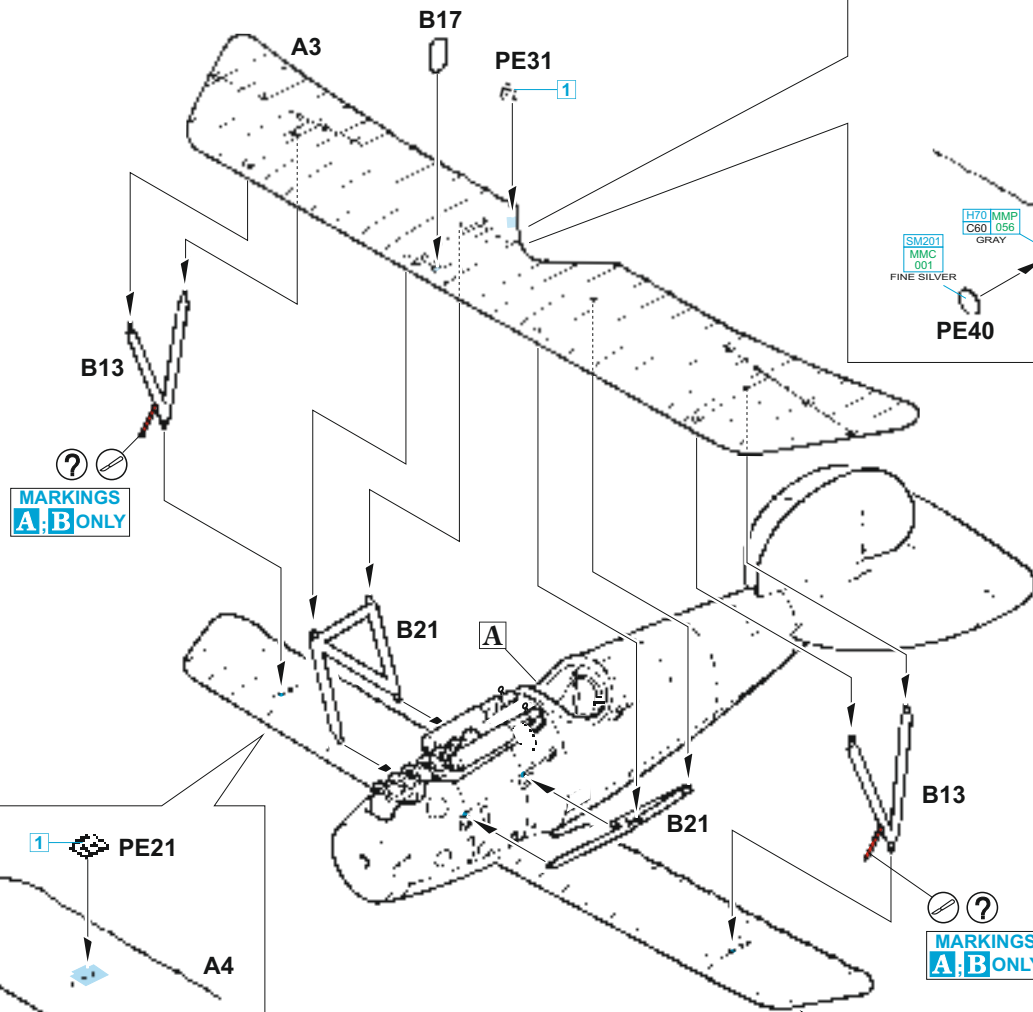
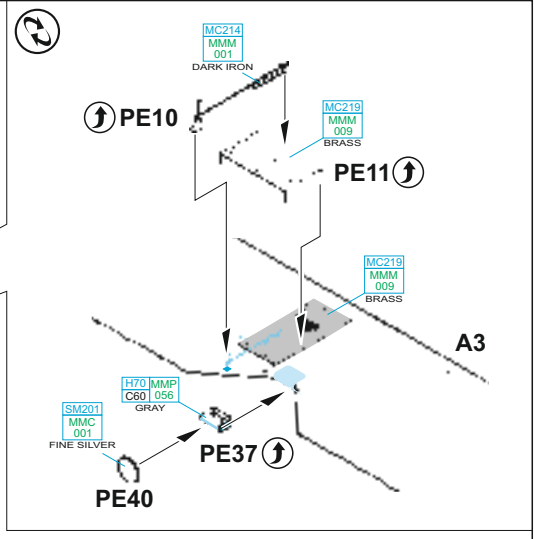



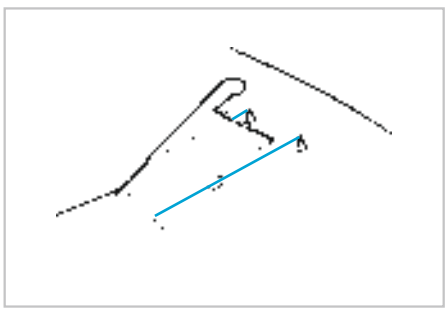
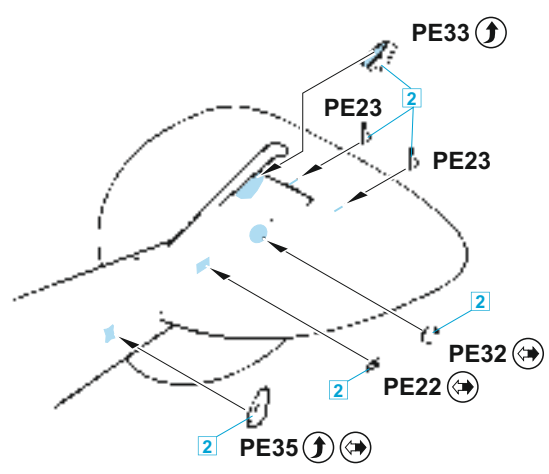
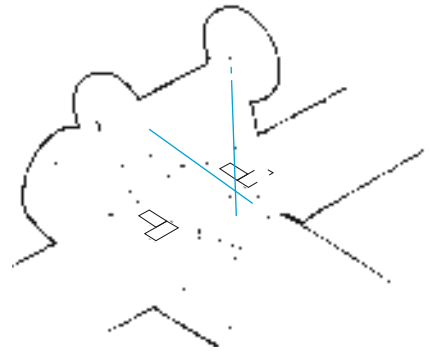
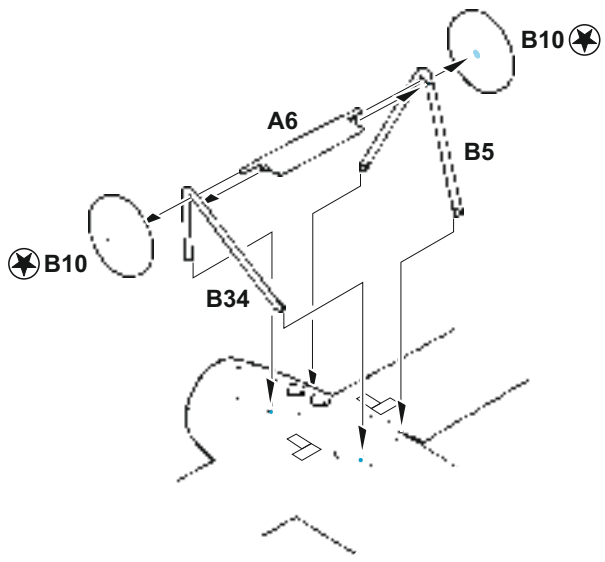

CAMOUFLAGE COLOR  
 2 = H70 MMP - MARKINGS A; C  
 C60 056 - MARKING B  
 GRAY

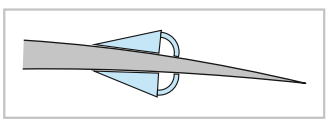
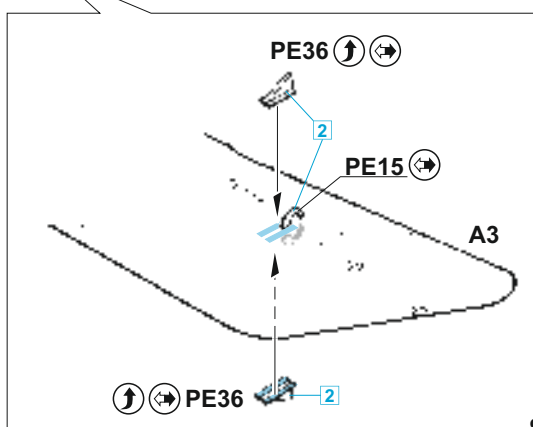
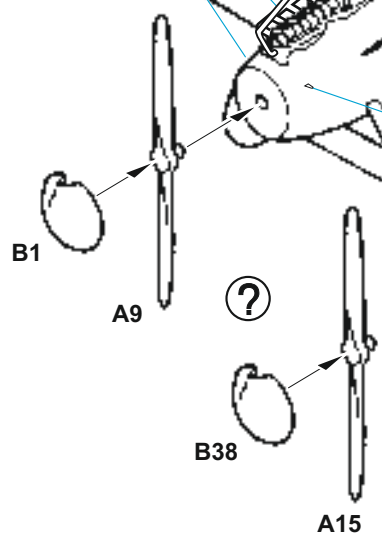
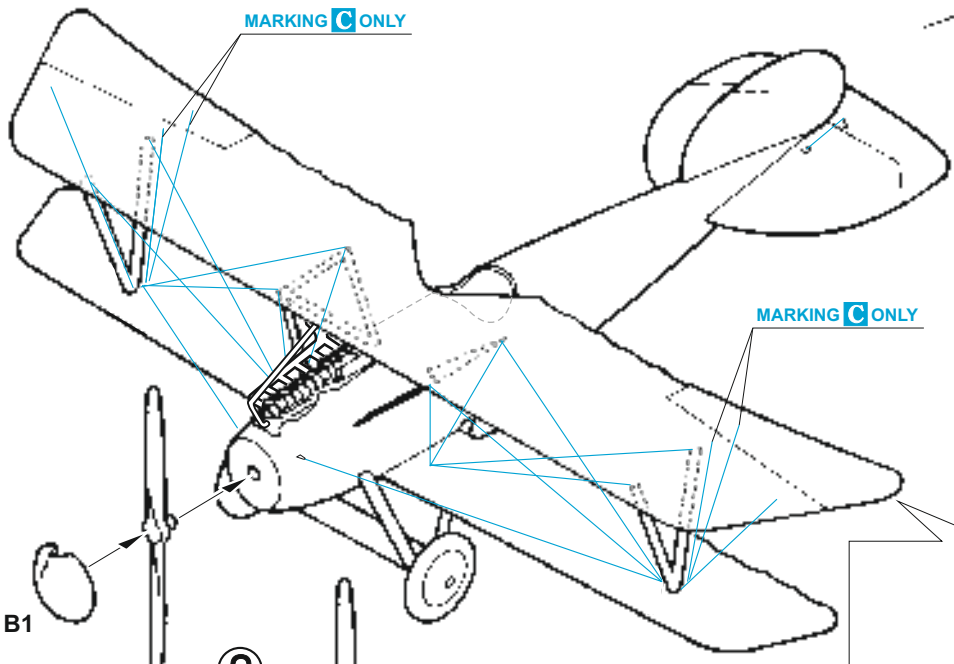
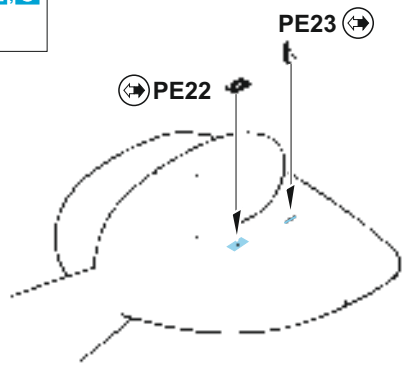



Carefully read instruction sheet before assembling. When you use glue or paint, do not use near open flame and use in well ventilated room. Keep out of reach of small children. Children must not be allowed to suck any part, or pull vinyl bag over the head.



Před započatím stavby si pečlivě prostudujte stavební návod. Při používání barev a lepidel pracujte v dobře větrané místnosti. Lepidla ani barvy nepoužívejte v blízkosti otevřeného ohně. Model není určen malým dětem, mohlo by dojít k požití drobných dílů.



OPTIONAL  
VOLBA



BEND  
OHNOUT



SAND  
BROUSIT



OPEN HOLE  
VYVRTAT OTVOR



SYMETRICAL ASSEMBLY  
SYMETRICKÁ MONTÁŽ



REMOVE  
ODŘÍZNOUT



REVERSE SIDE  
OTOČIT



APPLY EDUARD MASK  
AND PAINT  
POUŽÍT EDUARD MASK  
NABARVIT



## PLASTIC PARTS

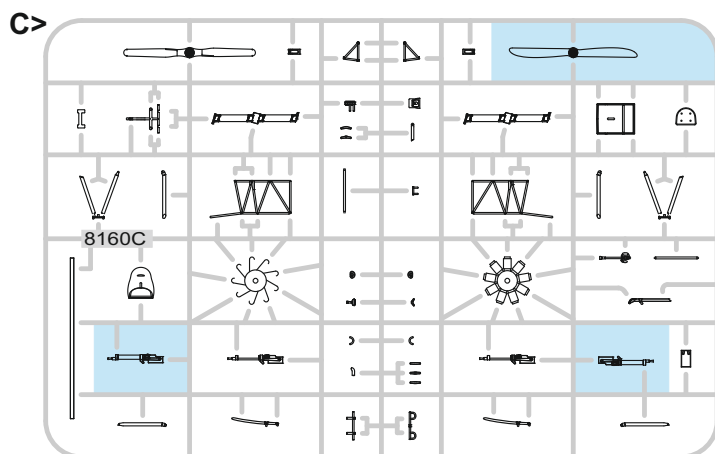
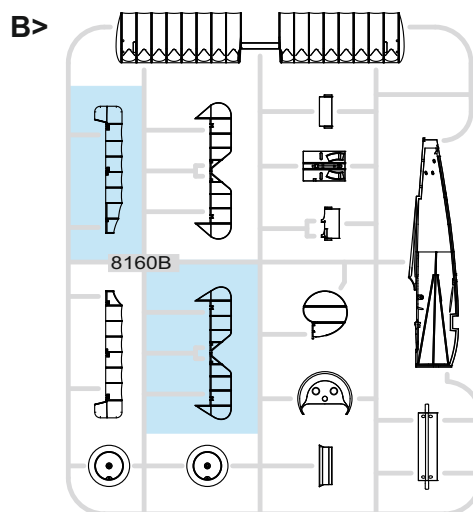
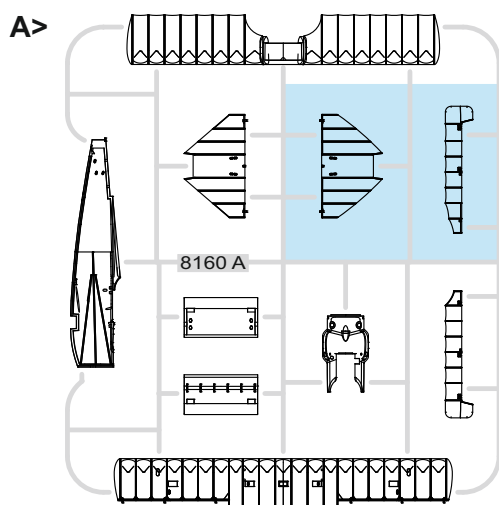

## FILM

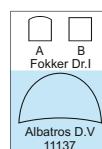

## PE - PHOTO ETCHED DETAIL PARTS

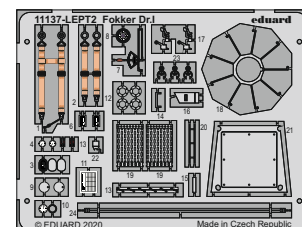
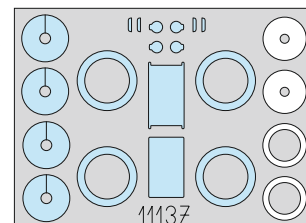
eduard  
MASK

-Parts not for use. -Teile werden nicht verwendet. -Pièces à ne pas utiliser. -Tyto díly nepoužívejte při stavbě. -



GSI Creos (GUNZE)		MISSION MODELS	
AQUEOUS	Mr.COLOR	PAINTS	
H11	C62	MMP-001	FLAT WHITE
H12	C33	MMP-047	FLAT BLACK
H27	C44		TAN
H37	C43		WOOD BROWN
H47	C41	MMP-012	RED BROWN
H51	C11	MMP-063	LIGHT GULL GRAY
H52	C12	MMP-091	OLIVE DRAB
H67	C115	MMP-057	LIGHT BLUE

GSI Creos (GUNZE)		MISSION MODELS	
AQUEOUS	Mr.COLOR	PAINTS	
H70	C60	MMP-056	GRAY
H85	C45		SAIL COLOR
H422	C122	MMP-053	LIGHT GREEN
Mr.METAL COLOR		METALLICS	
MC214		MMM-001	DARK IRON
MC218		MMM-003	ALUMINIUM
MC219		MMM-009	BRASS

# Fokker Dr.I

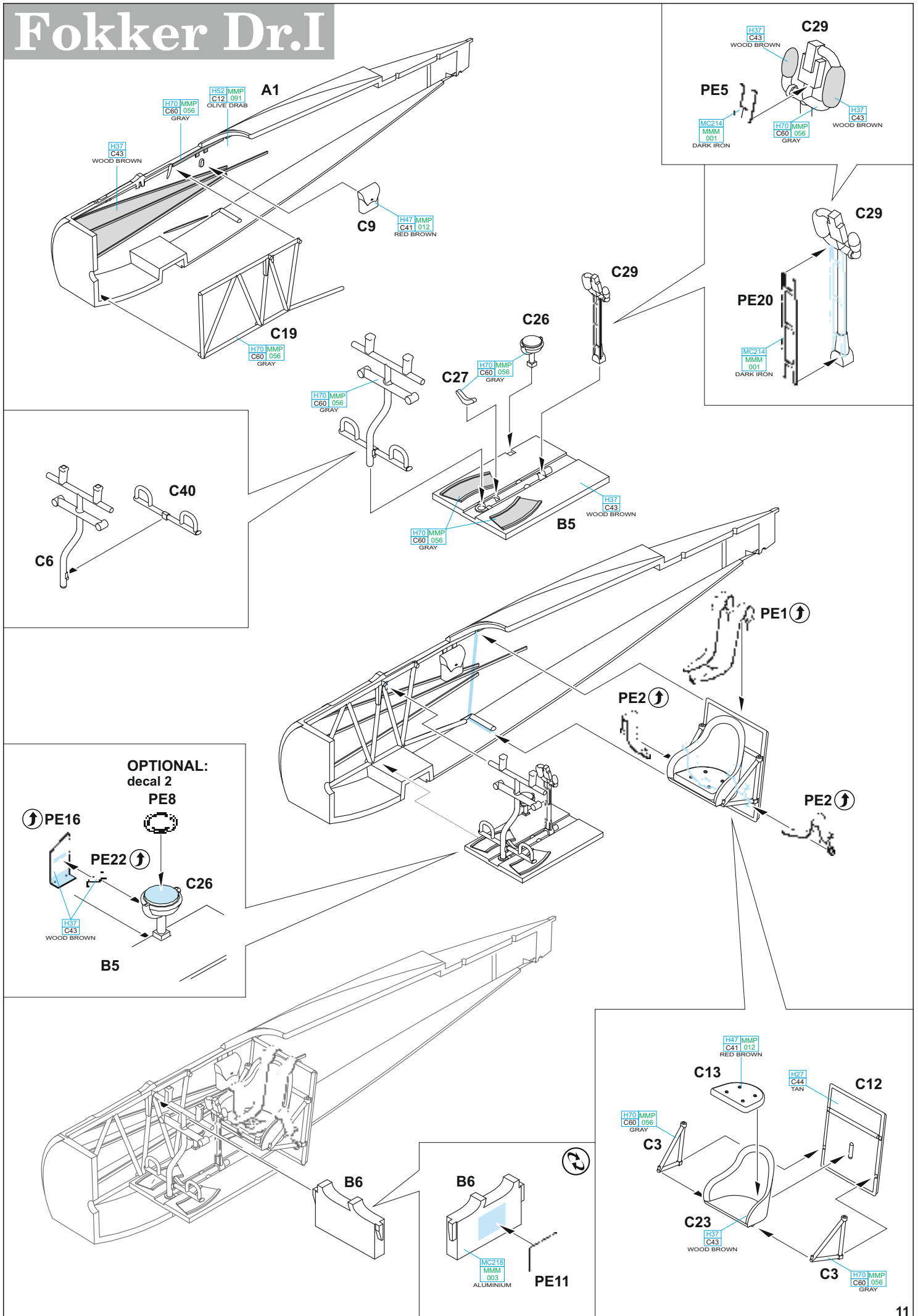

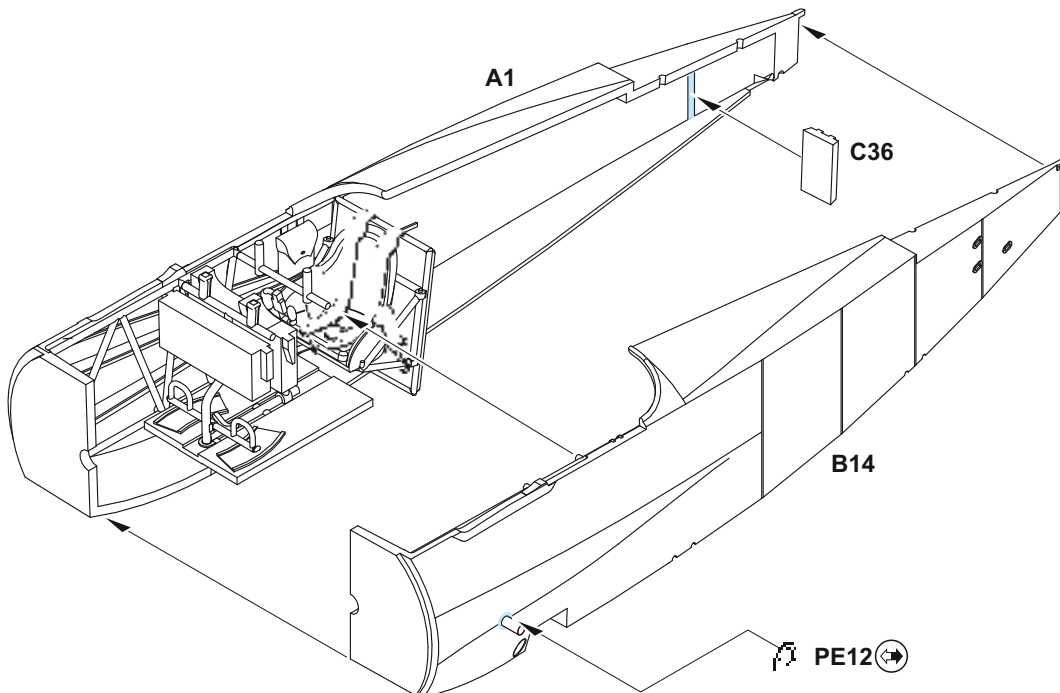
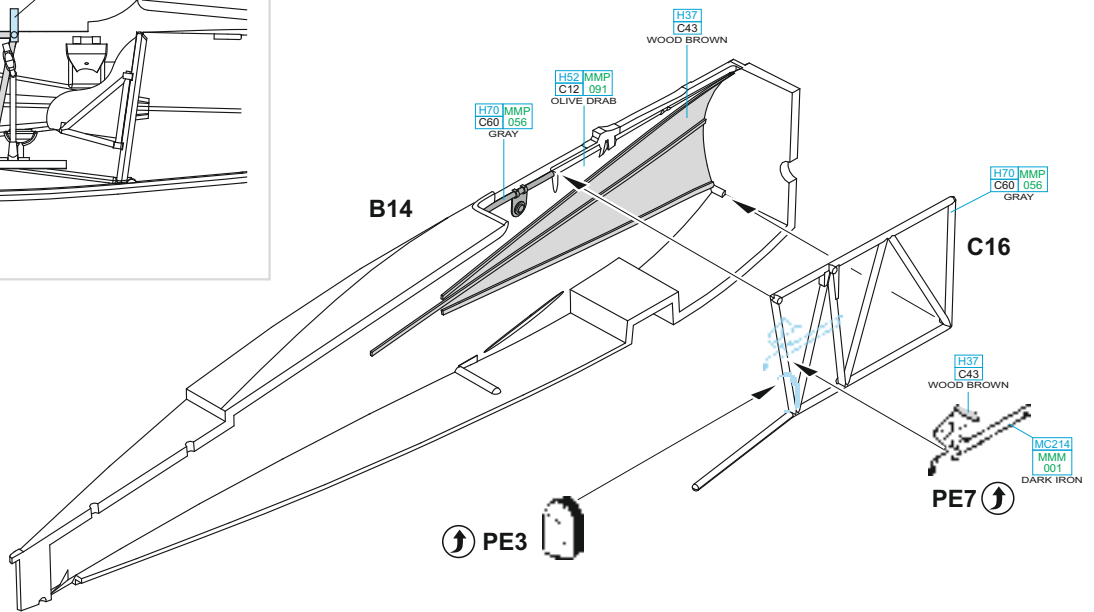
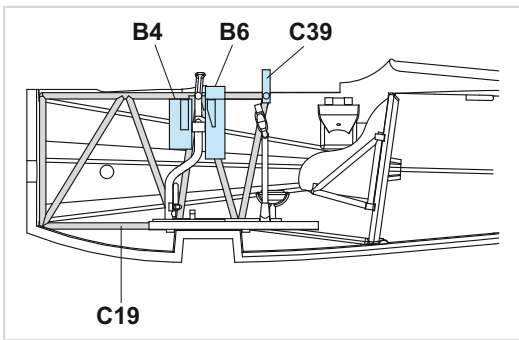
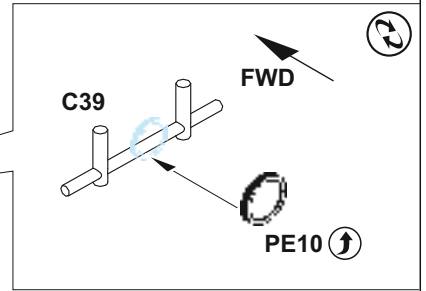
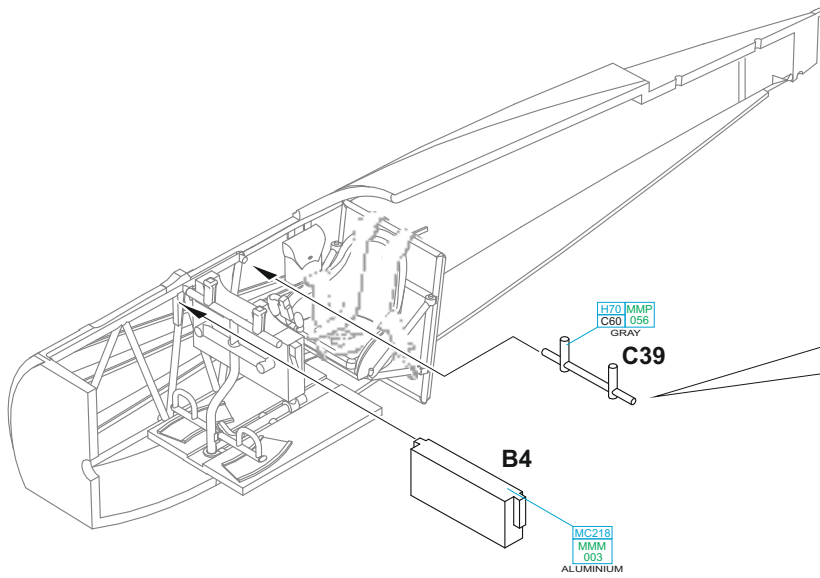

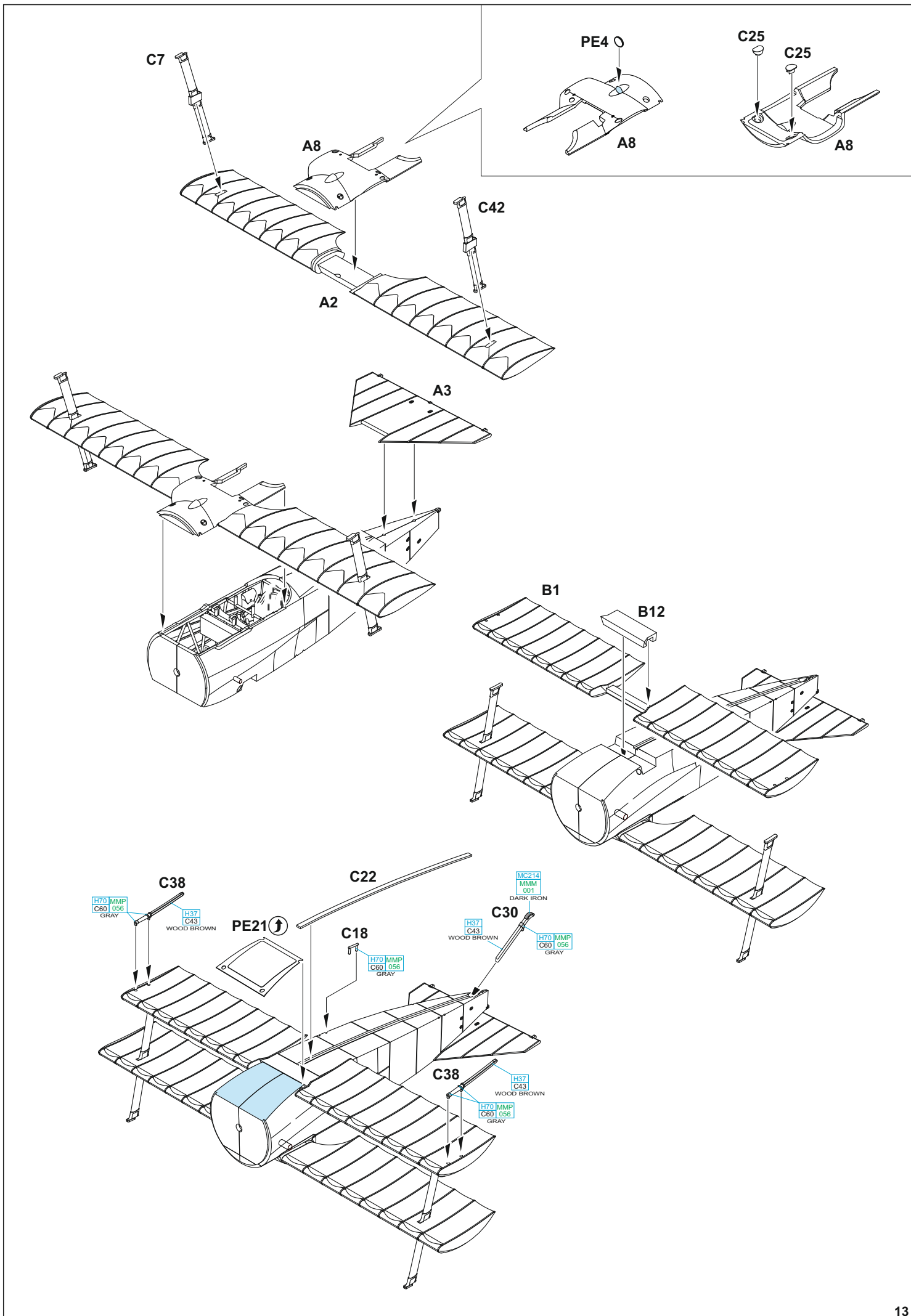

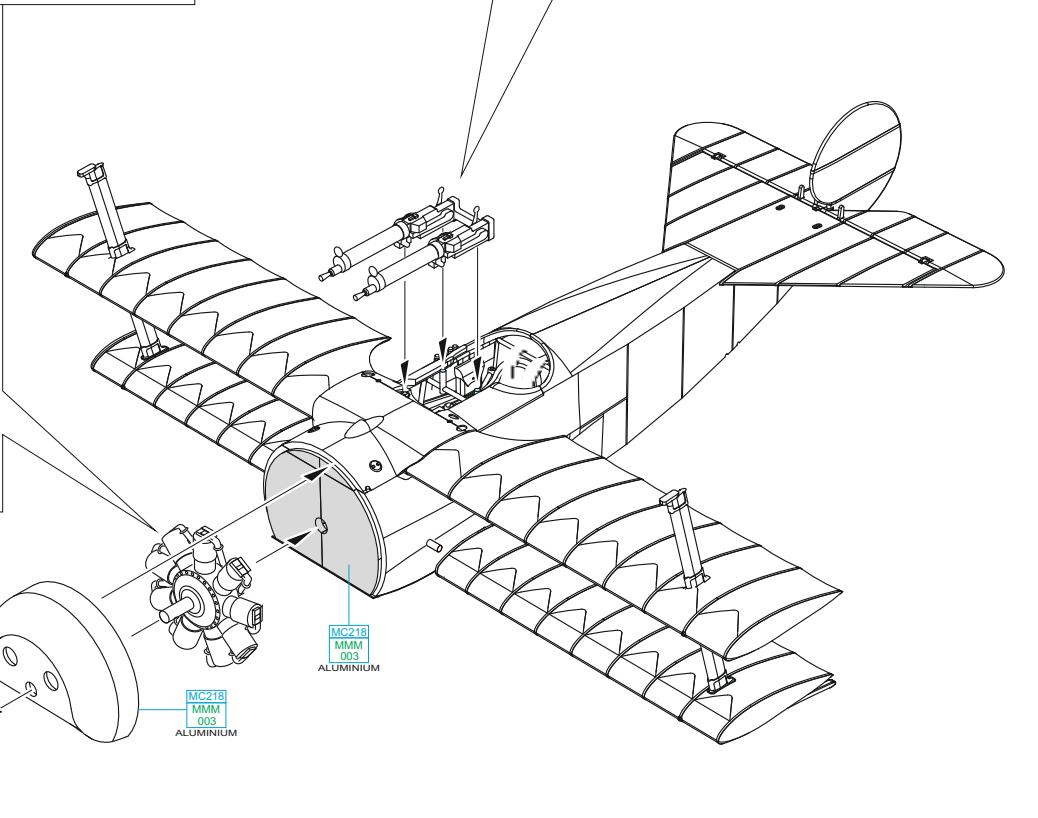
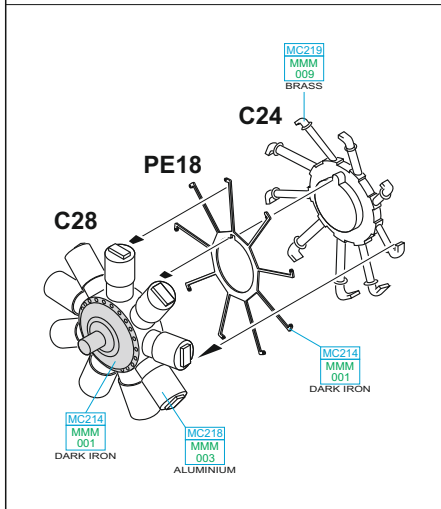
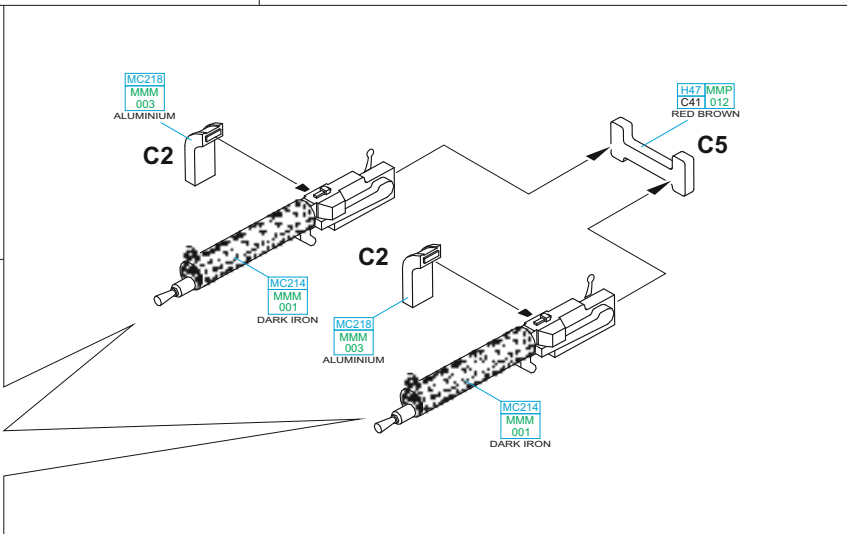
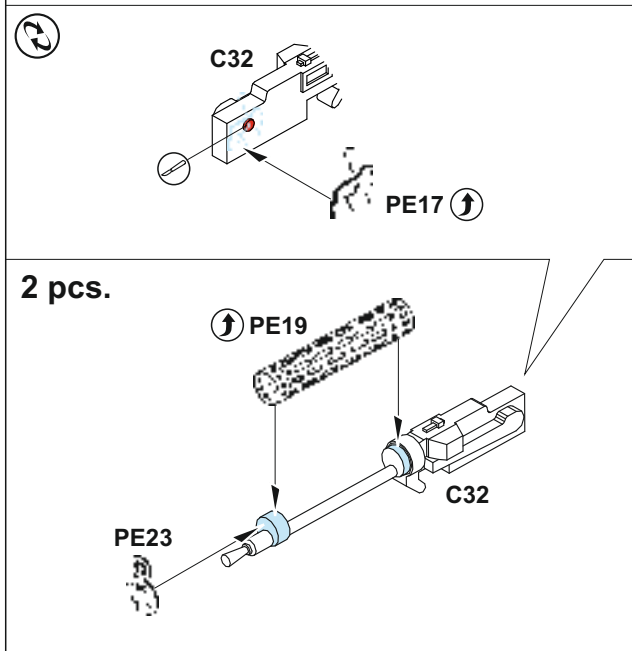
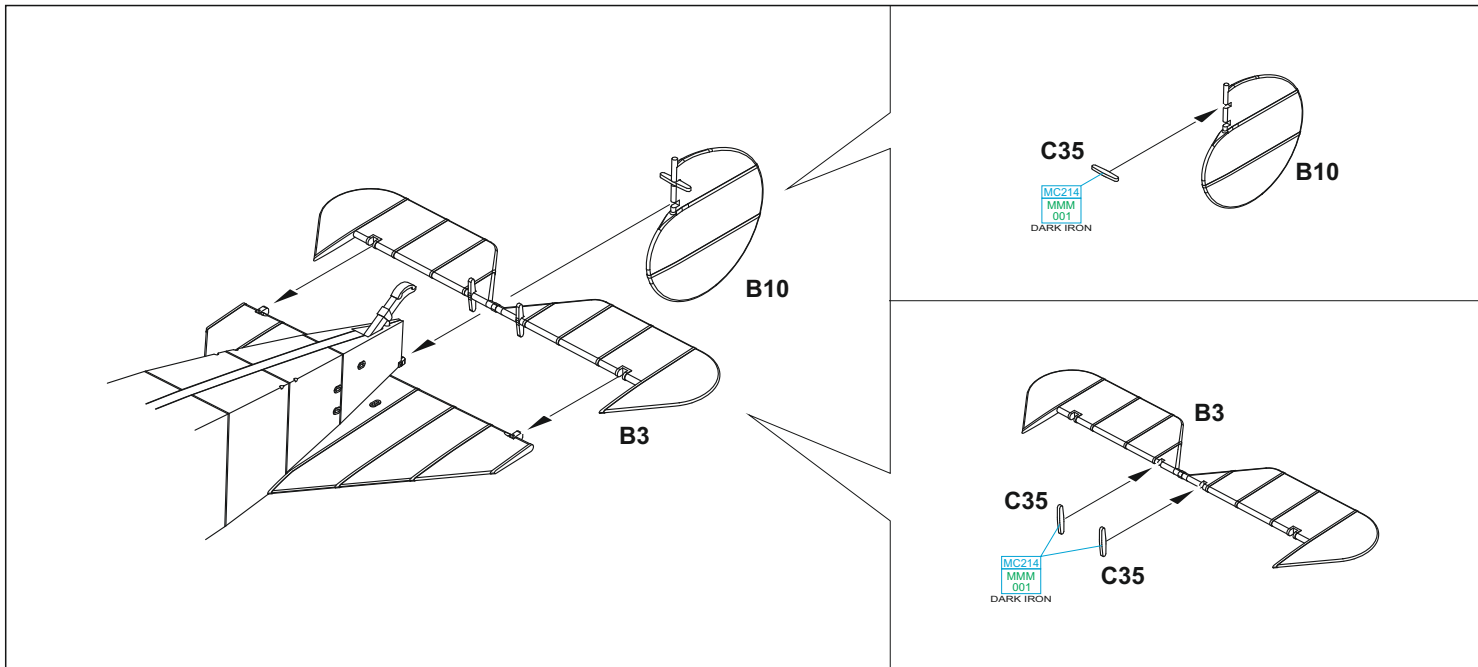

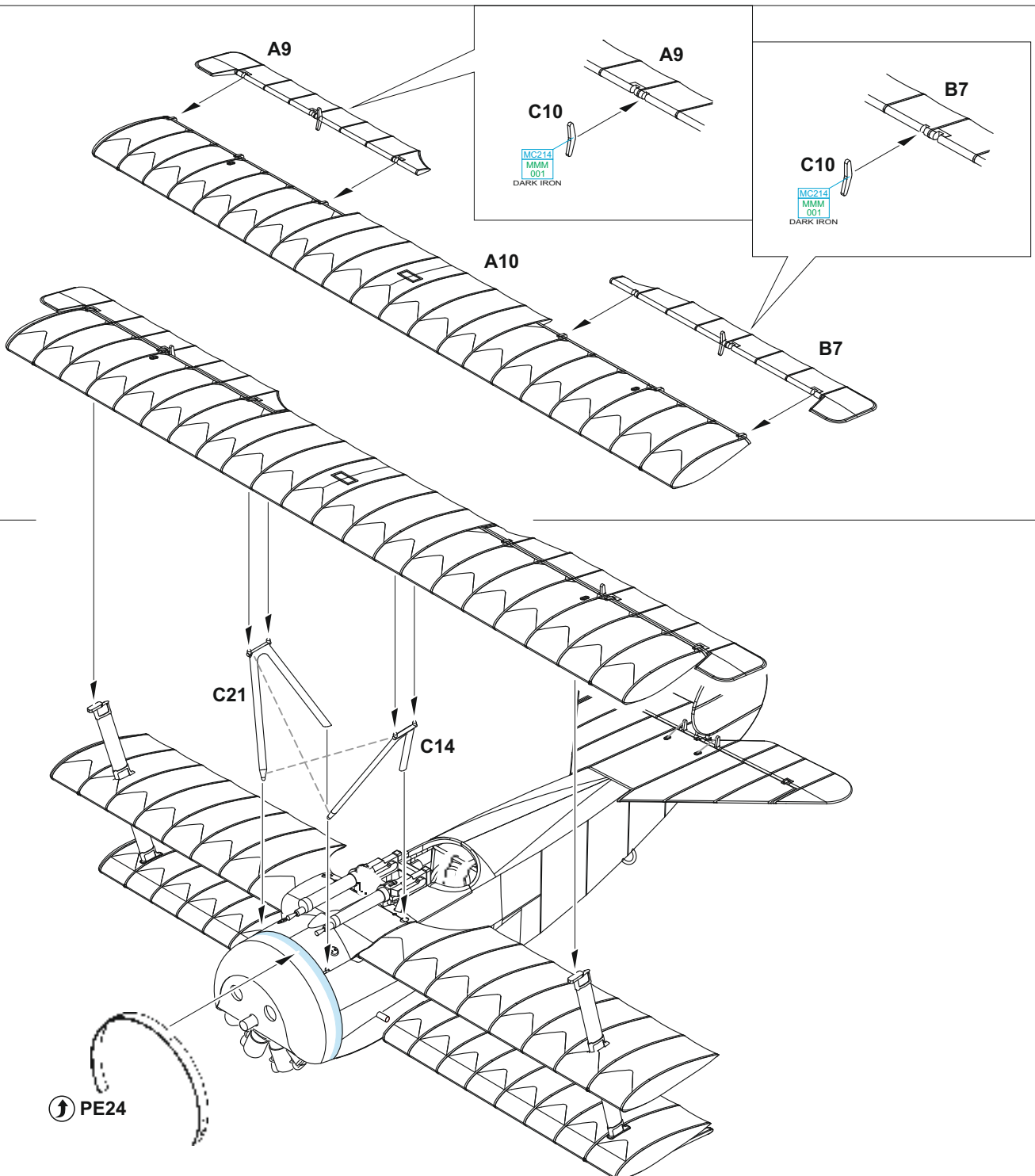
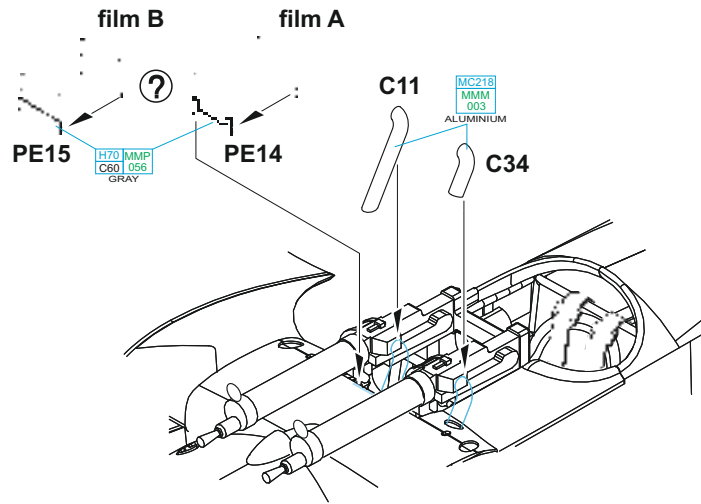

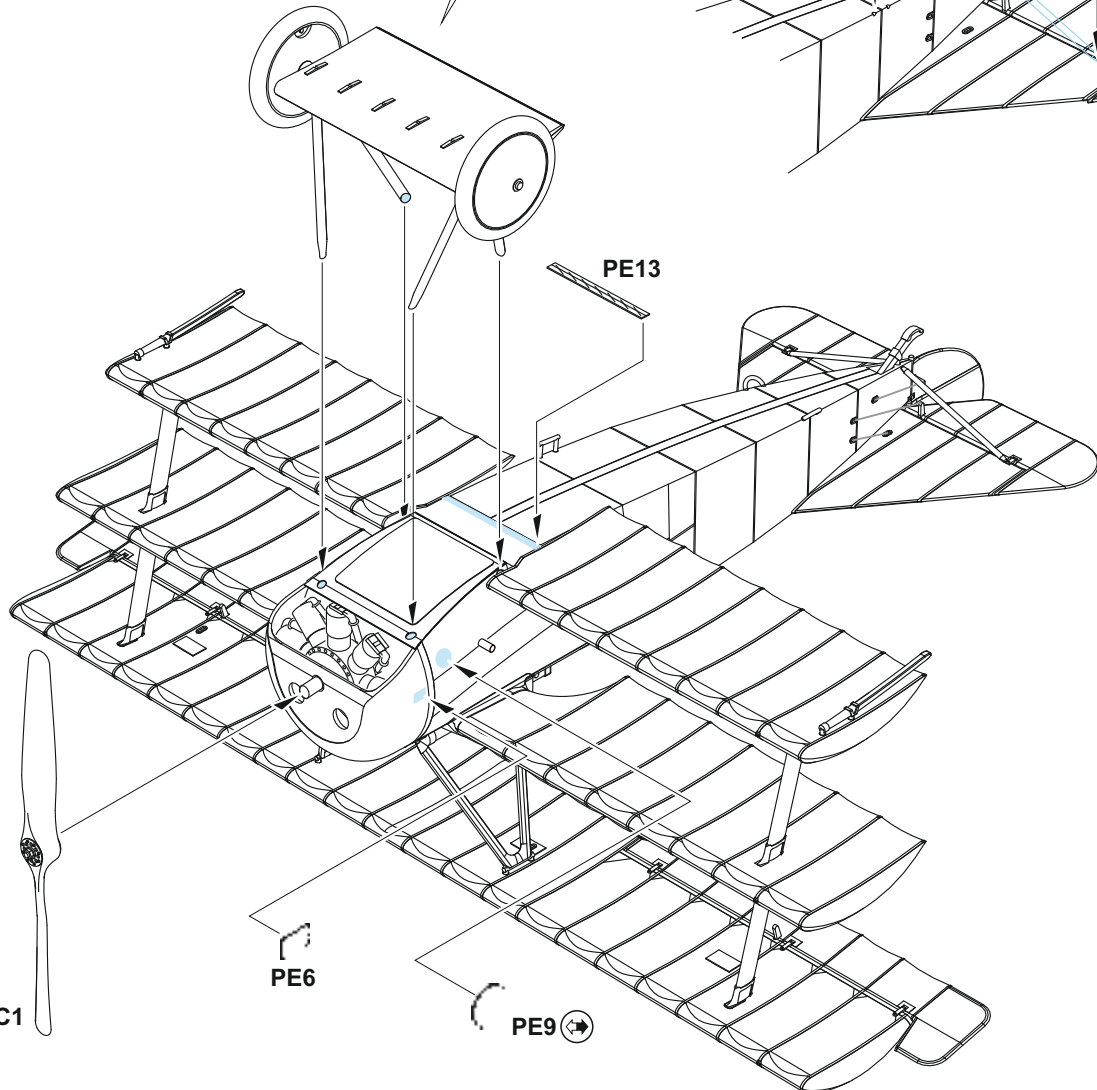
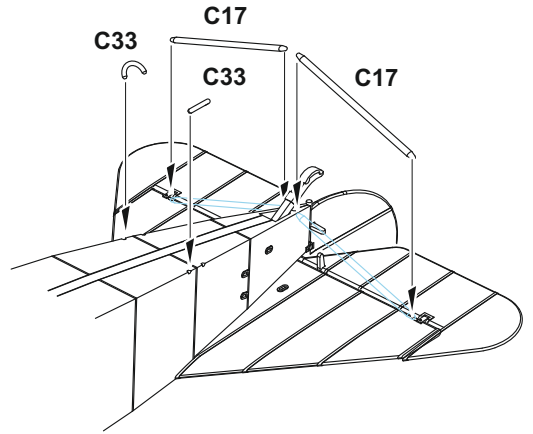
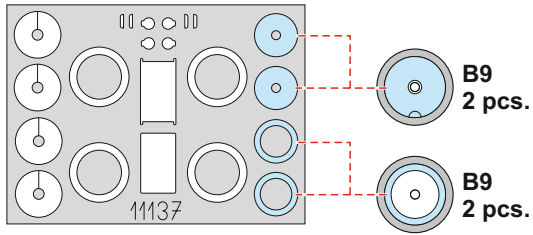
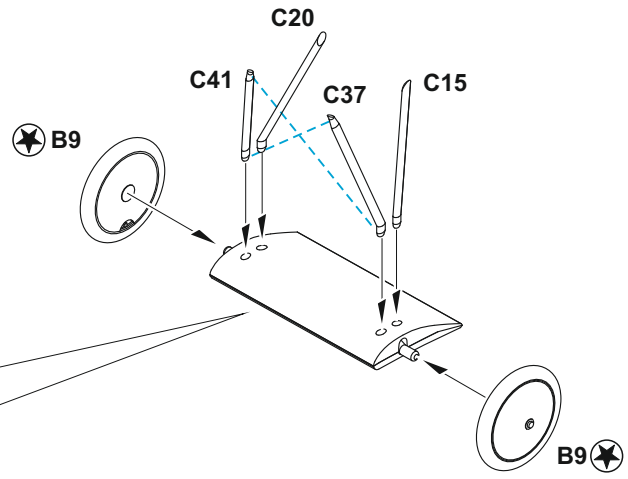
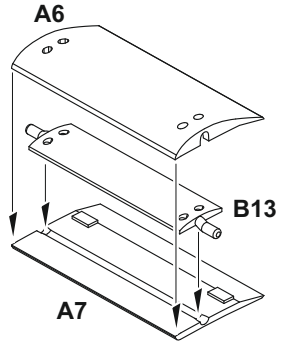





Carefully read instruction sheet before assembling. When you use glue or paint, do not use near open flame and use in well ventilated room. Keep out of reach of small children. Children must not be allowed to suck any part, or pull vinyl bag over the head.



Před započítím stavby si pečlivě prostudujte stavební návod. Při používání barev a lepidel pracujte v dobře větrané místnosti. Lepidla ani barvy nepoužívejte v blízkosti otevřeného ohně. Model není určen malým dětem, mohlo by dojít k požití drobných dílů.

## INSTRUCTION SIGNS \* INSTR. SYMBOLS \* INSTRUKTION SINNBILDEN \* SYMBOLES \* 記号の説明

OPTIONAL  
VOLBABEND  
OHNOUTSAND  
BROUSITOPEN HOLE  
VYVRTAT OTVORSYMETRICAL ASSEMBLY  
SYMETRICKÁ MONTÁŽREMOVE  
ODŘÍZNOUTREVERSE SIDE  
OTOČITAPPLY EDUARD MASK  
AND PAINT  
POUŽIT EDUARD MASK  
NABARVIT

## PARTS



## DÍLY



## TEILE



## PIÈCES



## PLASTIC PARTS

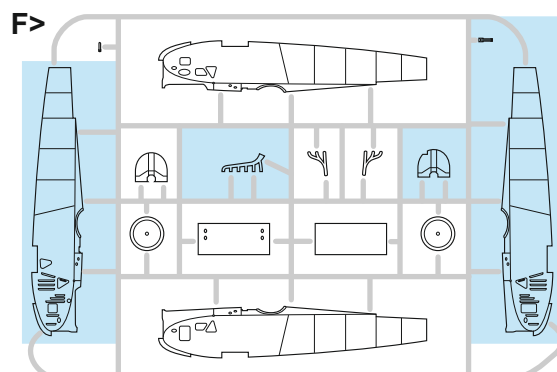
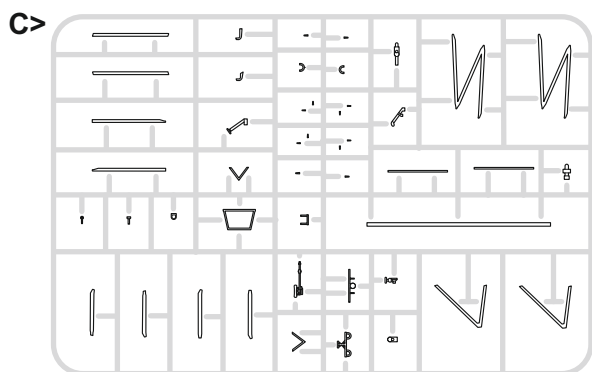
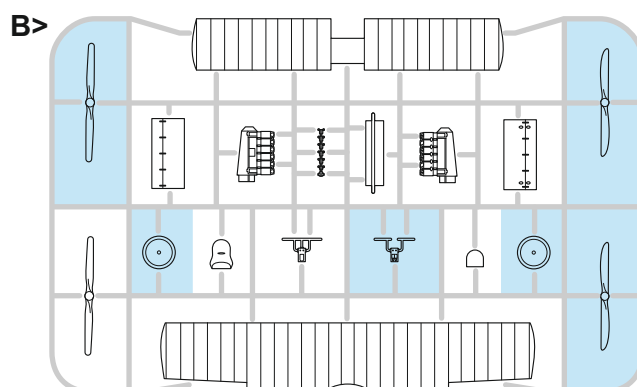
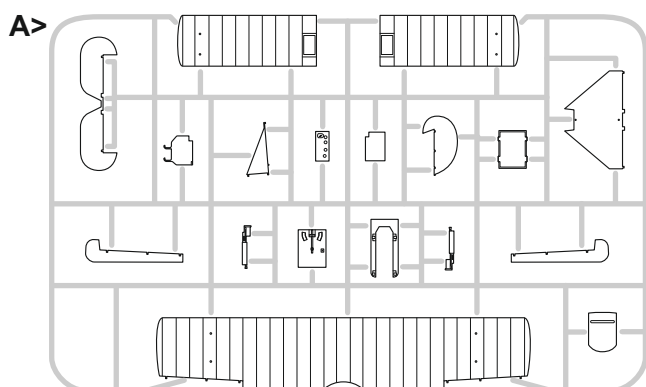

## PE - PHOTO ETCHED DETAIL PARTS

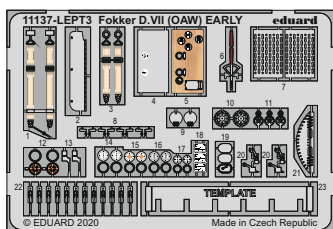

## eduard BRASS RP - RESIN PARTS



RP1



RP2



RP3



RP4

## eduard MASK

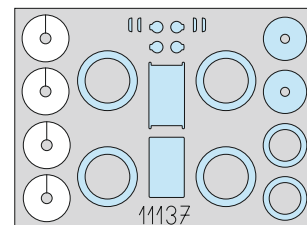

-Parts not for use. -Teile werden nicht verwendet. -Pièces à ne pas utiliser. -Tyto díly nepoužívejte při stavbě. -

## COLOURS



## BARVY



## FARBEN



## PEINTURE



GSI Creos (GUNZE)		MISSION MODELS	
AQUEOUS	Mr.COLOR	PAINTS	
H8	C8		SILVER
H11	C62	MMP-001	FLAT WHITE
H12	C33	MMP-047	FLAT BLACK
H13	C3	MMP-003	FLAT RED
H37	C43		WOOD BROWN
H39	C67		PURPLE
H47	C41	MMP-012	RED BROWN
H51	C11	MMP-063	LIGHT GULL GRAY

GSI Creos (GUNZE)		MISSION MODELS	
AQUEOUS	Mr.COLOR	PAINTS	
H53	C13		NEUTRAL GRAY
H85	C45		SAIL COLOR
H330	C361	MMP-077	DARK GREEN
H423	C123	MMP-054	DARK GREEN
Mr.METAL COLOR		METALLICS	
	MC214	MMM-001	DARK IRON
	MC219	MMM-009	BRASS

# Fokker D.VII

**A**

C28

PE16

H53 C13 NEUTRAL GRAY

**OPTIONAL:**  
decal 39

F13

PE2

F2

**B**

**OPTIONAL:**  
decal 40

C27

PE15

C33

C14

C17

C32

RP1

H37 C43 WOOD BROWN

H12 MMP C33 047 FLAT BLACK

H12 MMP C33 047 FLAT BLACK

H37 C43 WOOD BROWN

H8 C8 SILVER

H12 MMP C33 047 FLAT BLACK

H8 C8 SILVER

H47 MMP C41 012 RED BROWN

H53 C13 NEUTRAL GRAY

H53 C13 NEUTRAL GRAY

**eduard BRASSIN**

**RP1 - TO USE PILOT FIGURE ONLY**

B15

B12

C18

C32

H47 MMP C41 012 RED BROWN

H53 C13 NEUTRAL GRAY

H53 C13 NEUTRAL GRAY

**D TO USE THE PILOT FIGURE**

RP2

RP1

B

H47 MMP C41 012 RED BROWN

H53 C13 NEUTRAL GRAY

**eduard BRASSIN**

**C**

PE1

PE3

A11

decal A13

H85 C45 SAIL COLOR

**TO USE THE PILOT FIGURE**

decal A11

F13

A

B

C

?

**TO USE THE PILOT FIGURE**

decal A11

F13

A

D

?

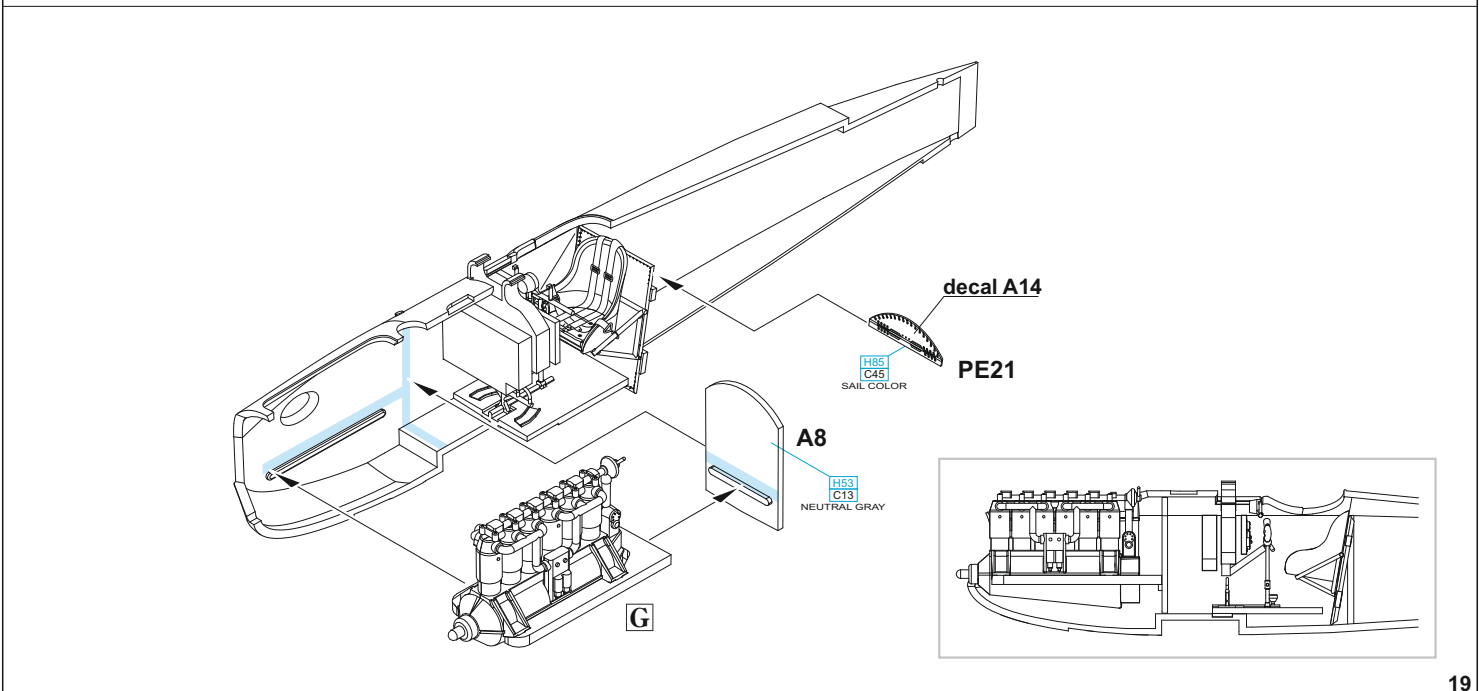
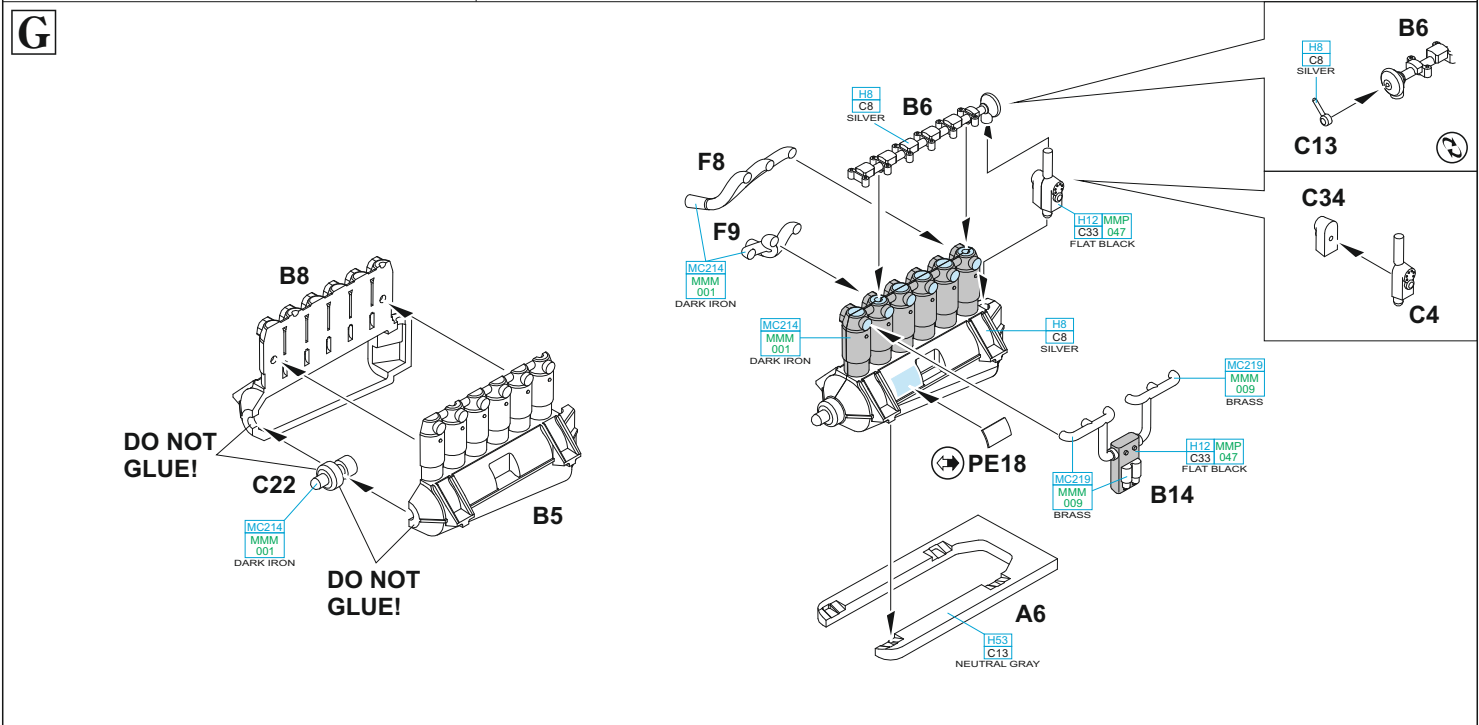
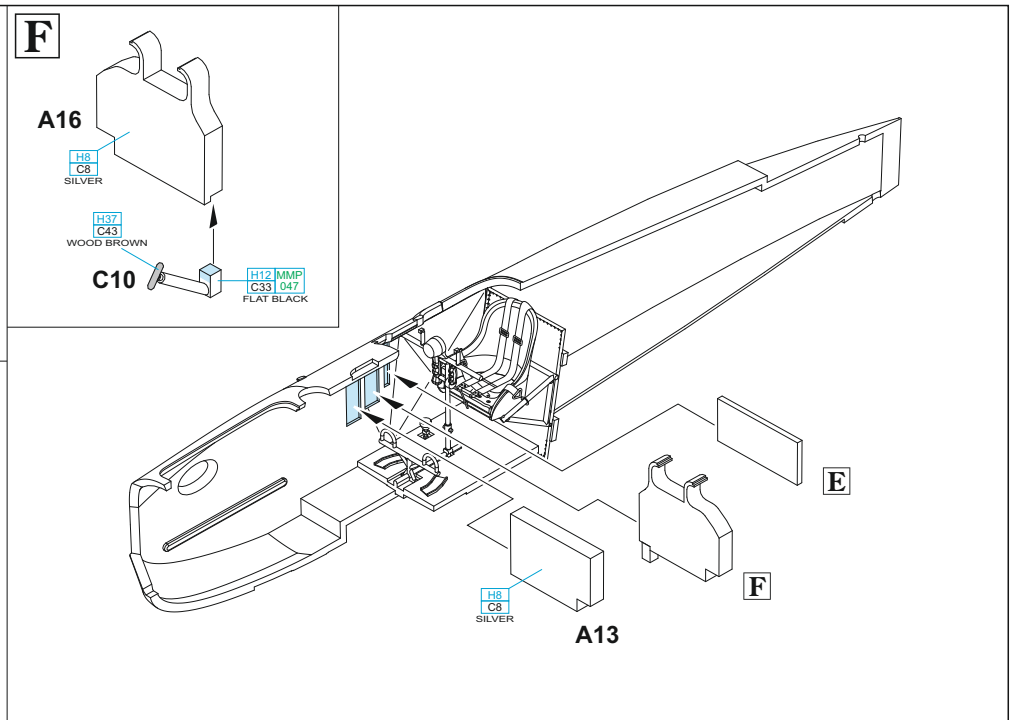
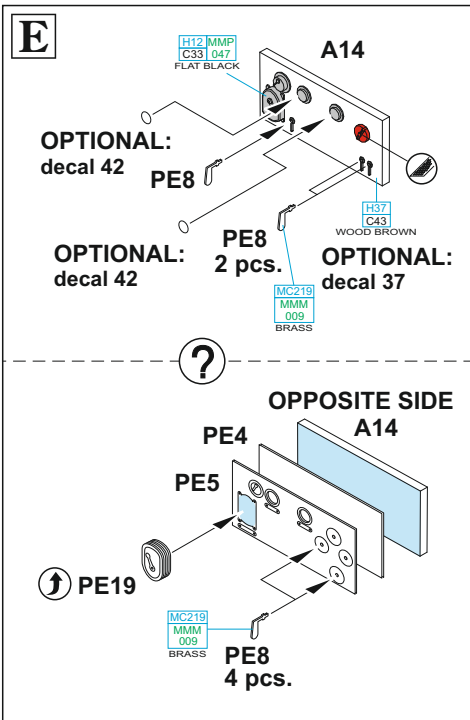

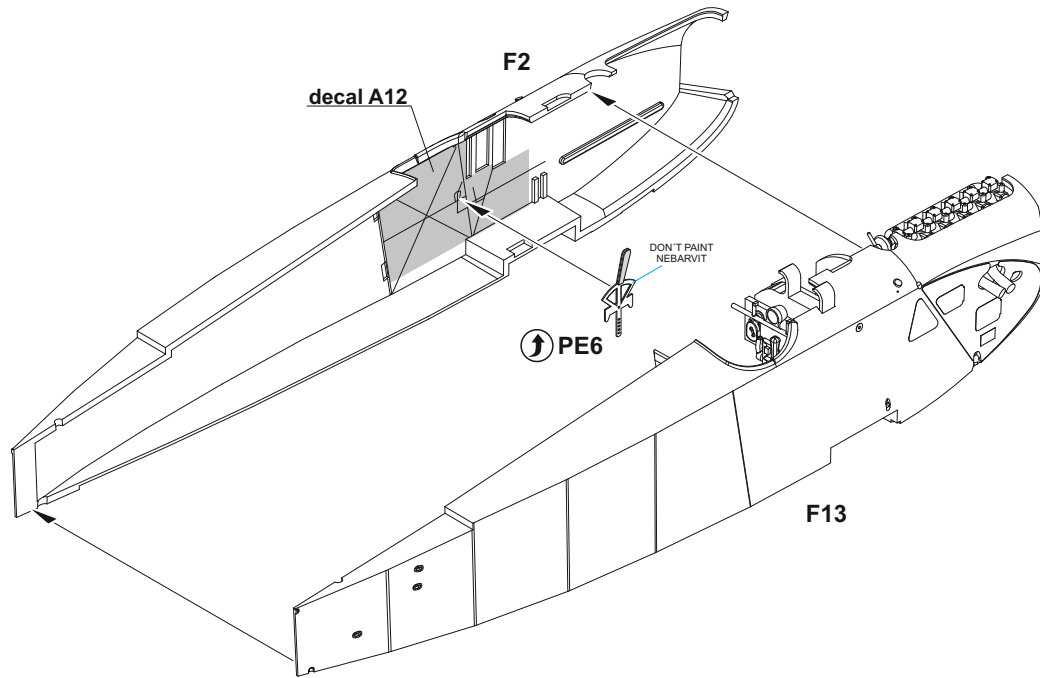

1	CAMOUFLAGE COLOR	- MARKING F
	H226 MMP C192 054	- MARKING C
	DARK GREEN	

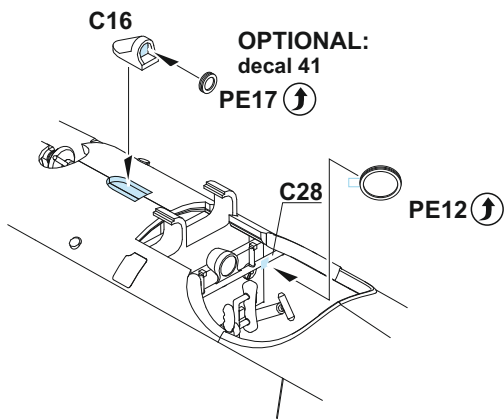

OPTIONAL:  
decal 41

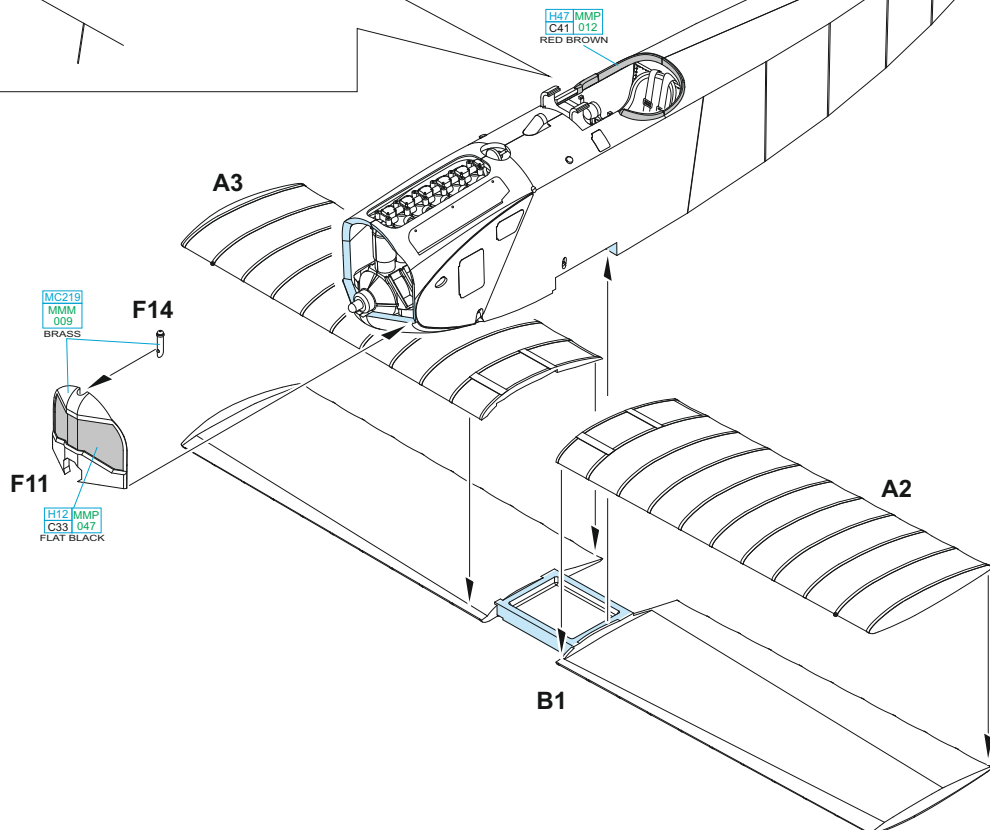
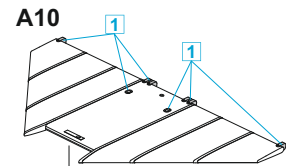

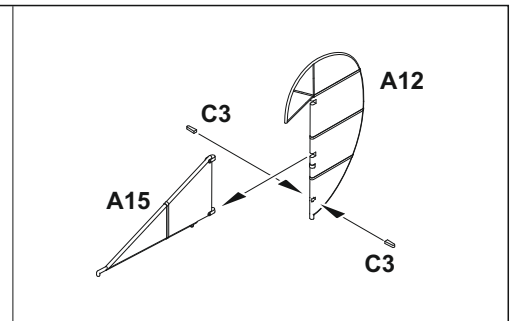
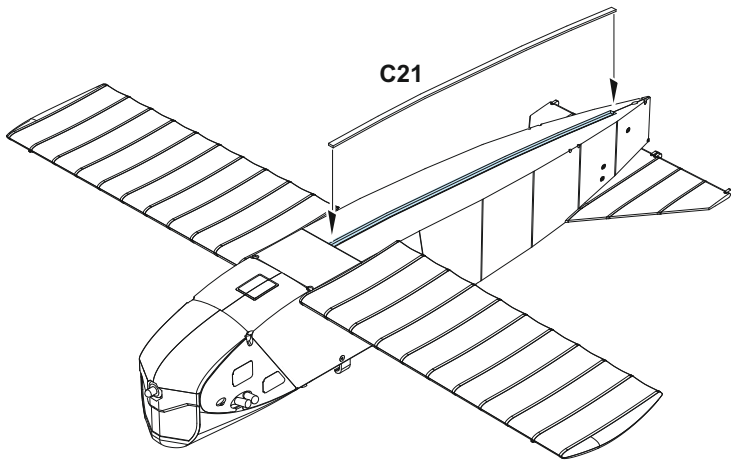

**APPLY LOZENGE DECALS IN THIS STEP**

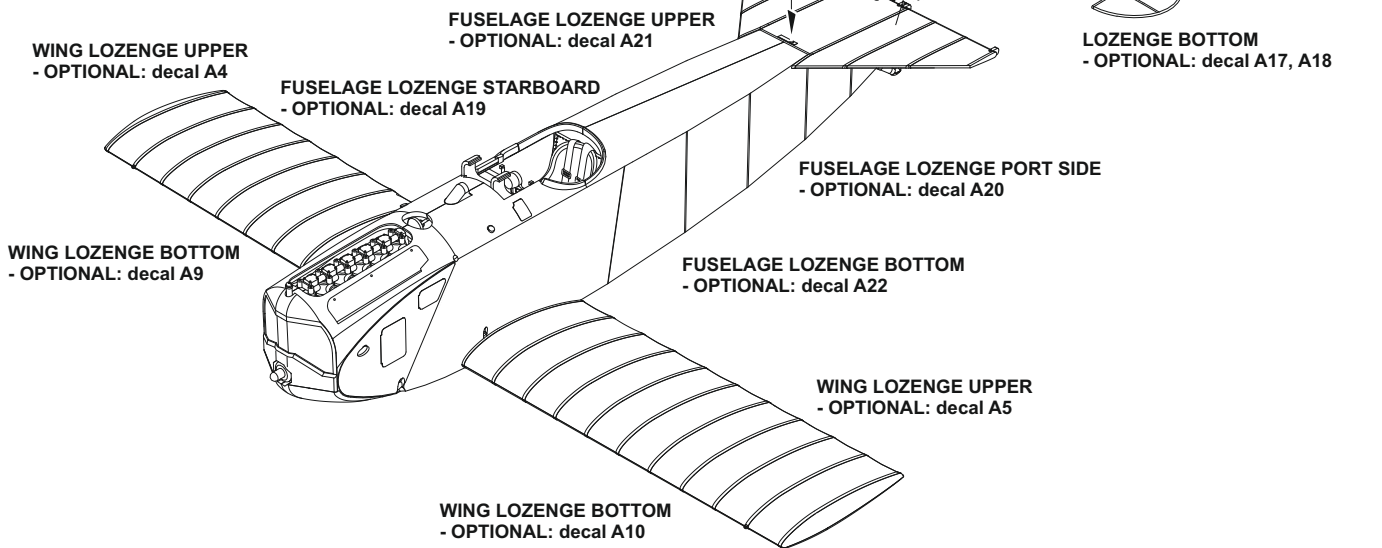

RIB STRIPES AND COMPLETE LOZENGE DECAL APPLICATION - SEE PAGE 31

**H** 2 pcs.

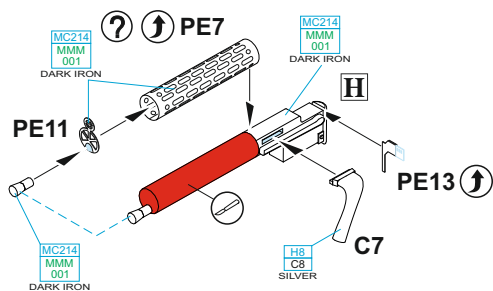
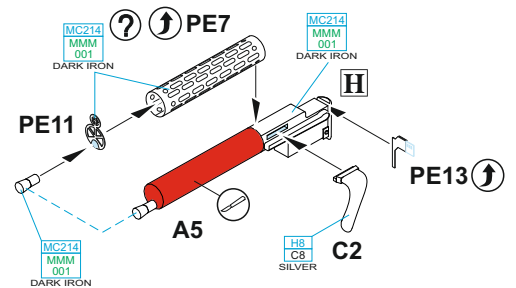
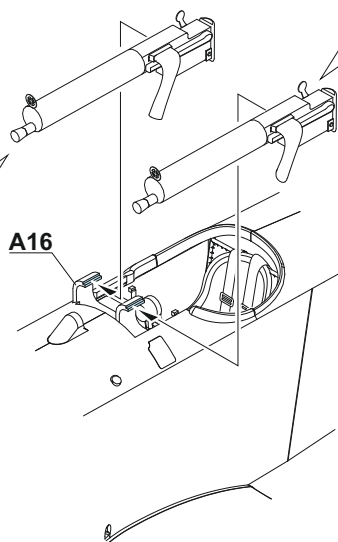
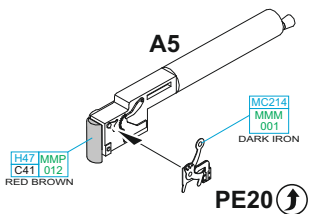

**APPLY LOZENGE DECALS IN THIS STEP**

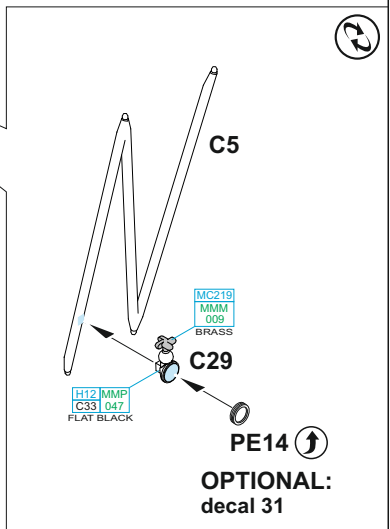
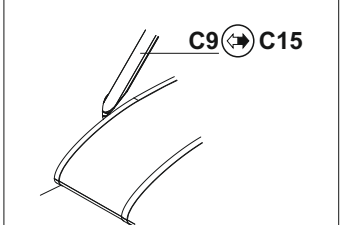
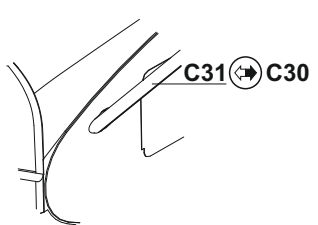
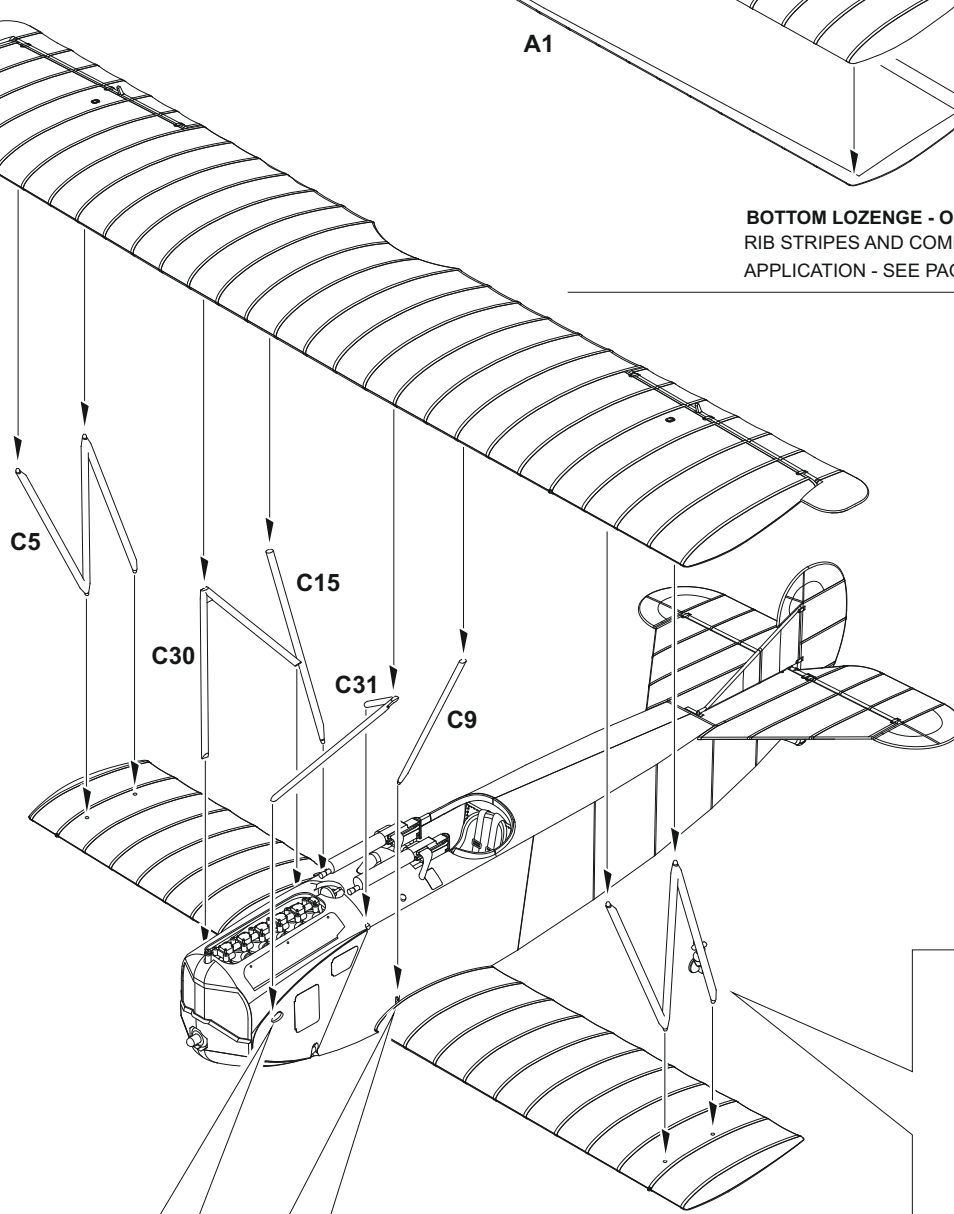
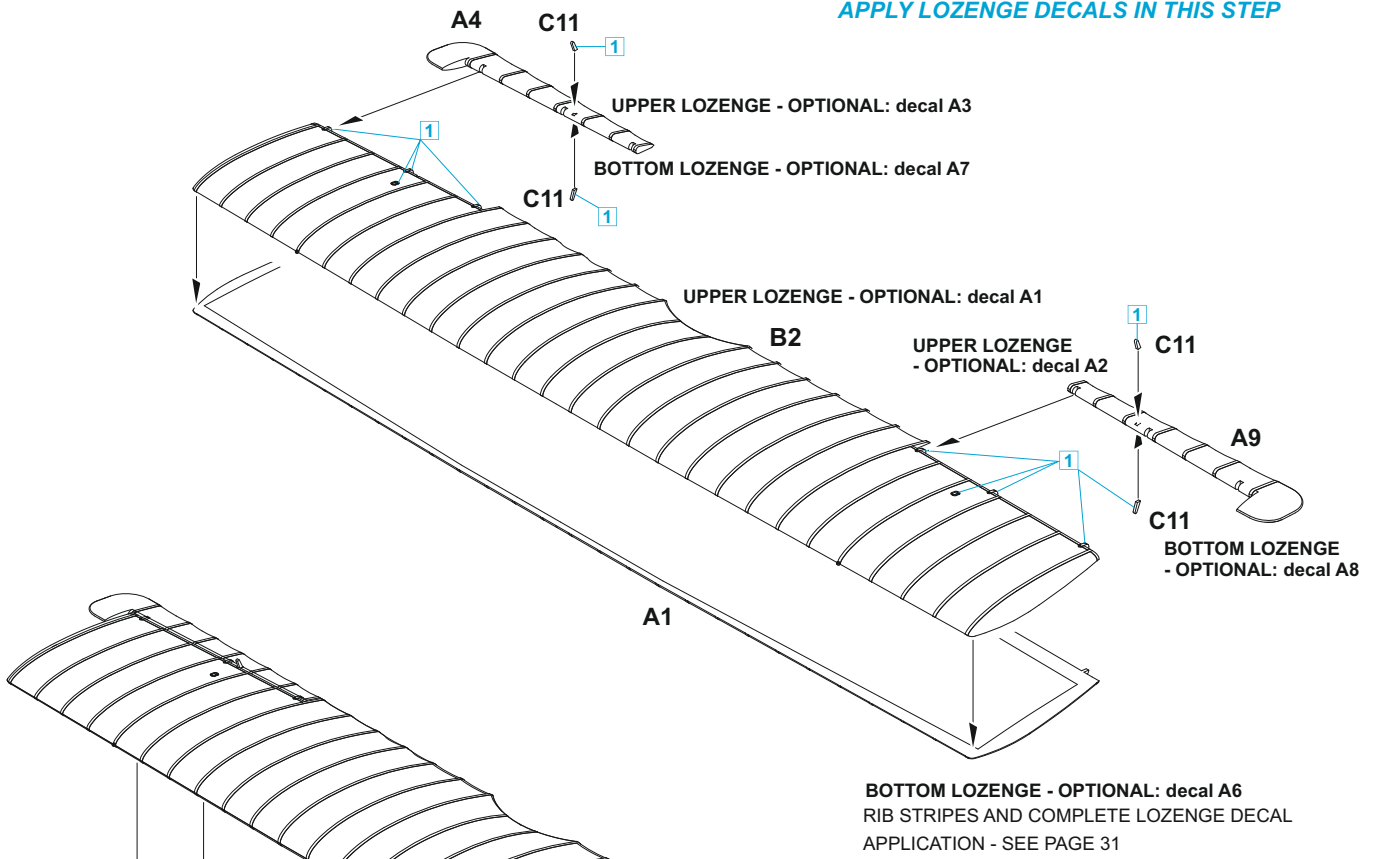

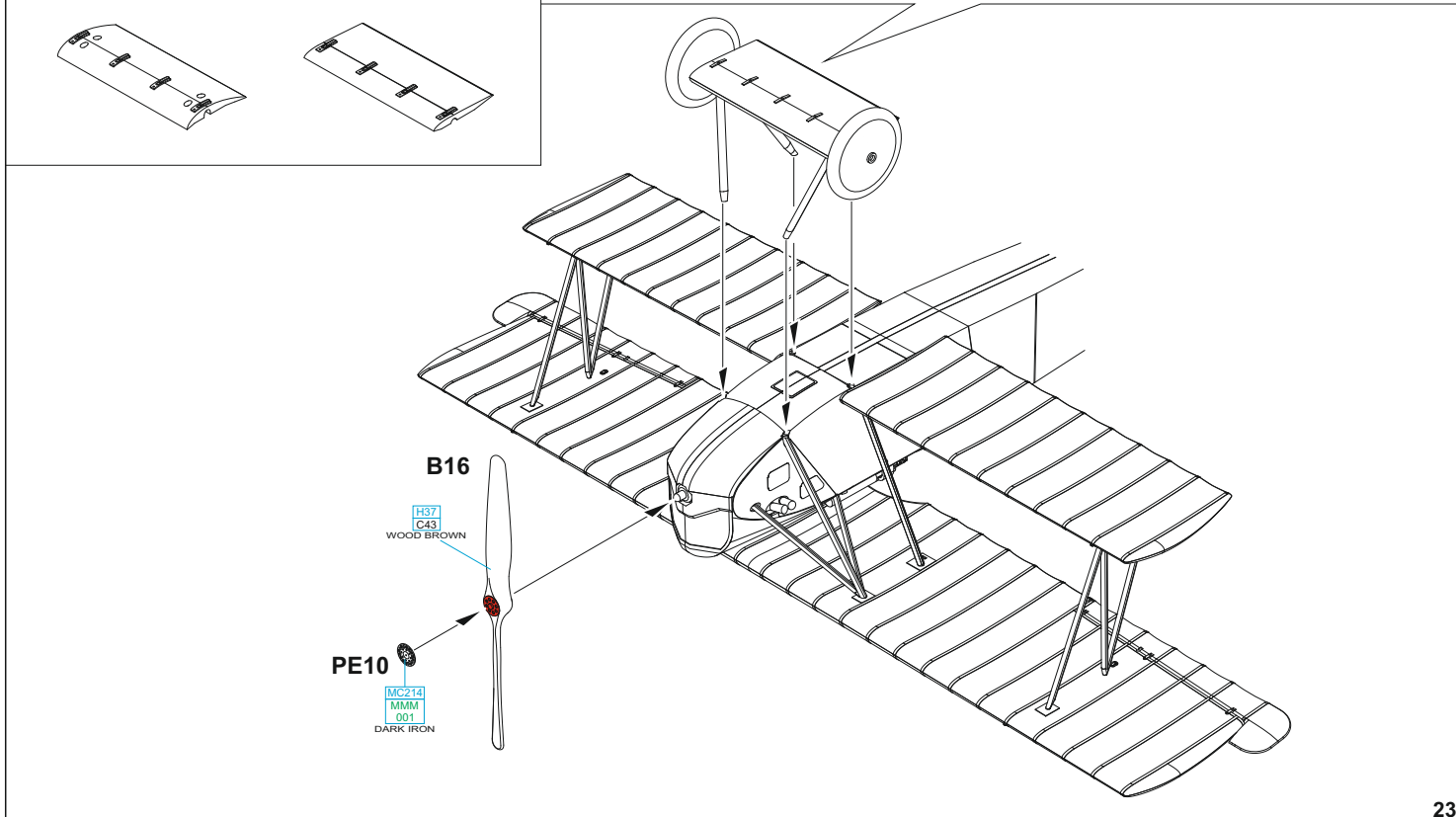
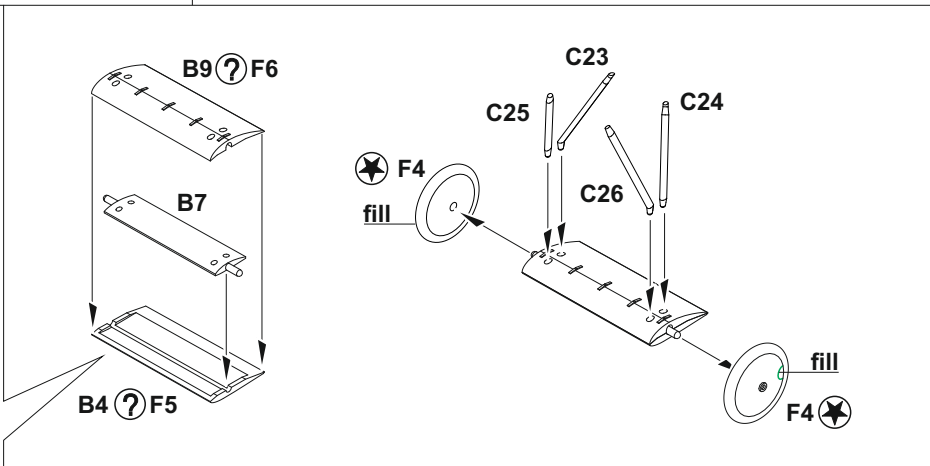
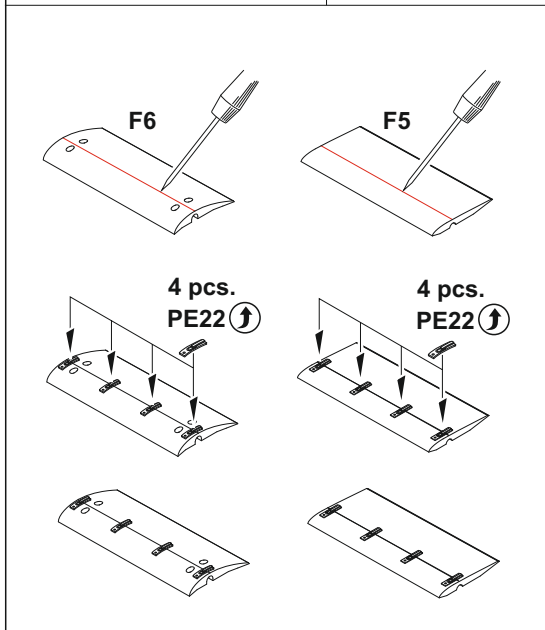
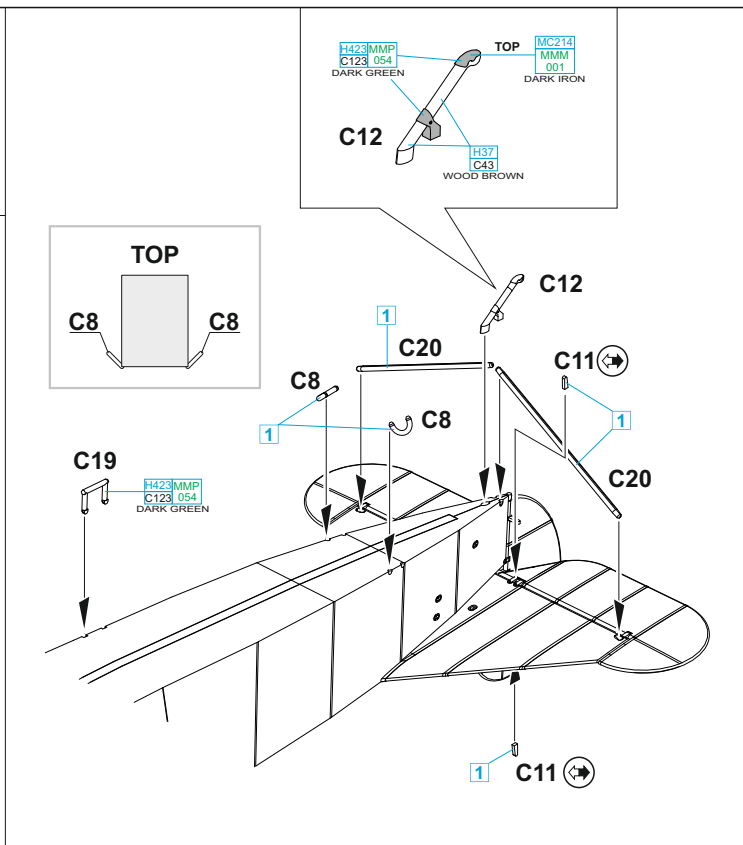
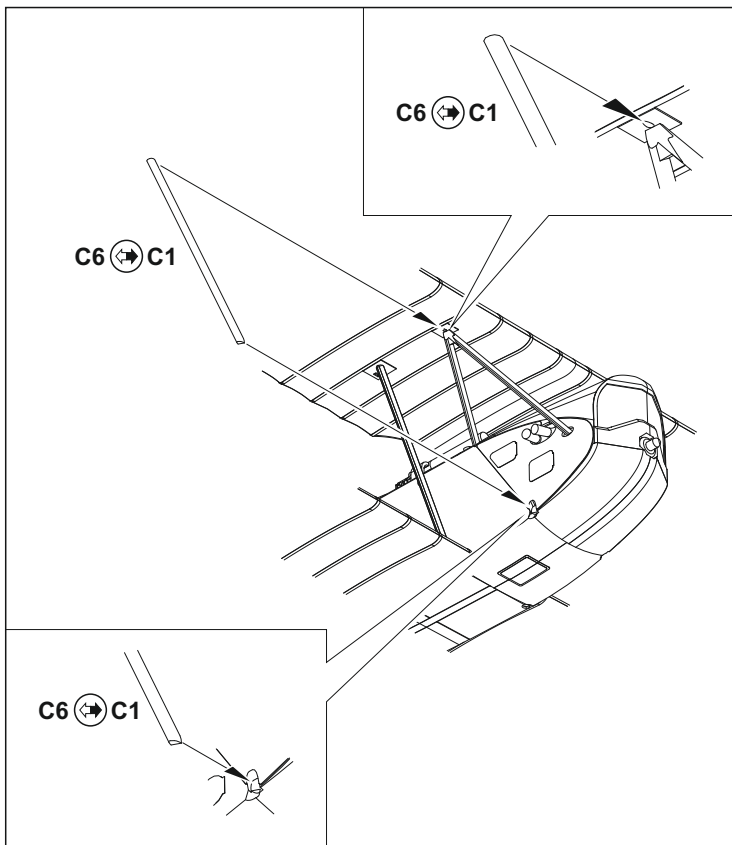

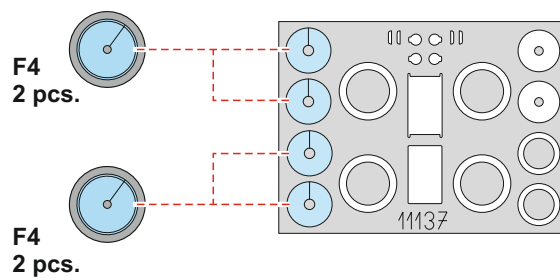
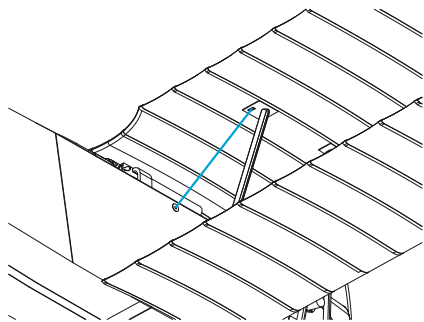
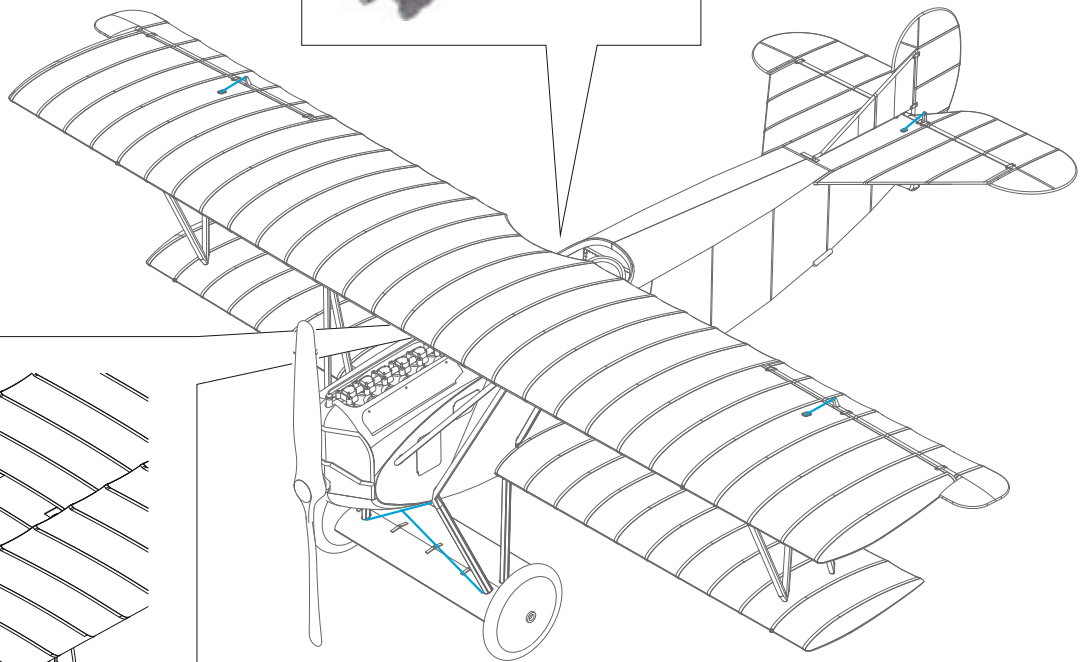
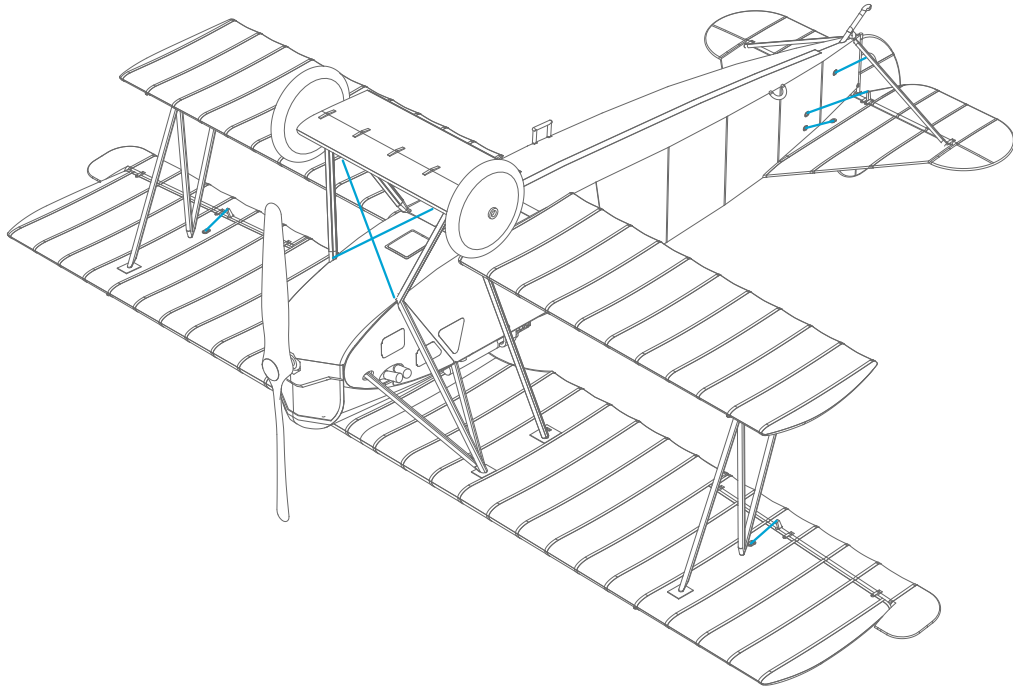



# A Albatros D.V Jasta 37, Wasquehal airfield, France, July 1917

Coming from Jasta 15, Udet was posted to Jasta 37 as a regular pilot on July 26th, 1917. This posting came at his own request, since several of his old comrades from his days in his old Kampfeinsatzkommando were now serving with that Jasta. This silver-painted Albatros D.V was supposedly his first plane in Jasta 37, and all known photos show it with an immaculate overall finish. The black-and-silver striped tail was the unit marking of Jasta 37, and this was actually retained until the end of the war. The silver colour was an overall finish applied to the plane, the metal cowling and spinner were painted black and there was a black stripe applied to the wheel hub, on this plane onto the inner wheel covers, too. The "LO" marking was placed quite close to the cockpit on this plane. The military number of this machine is unknown, as is its eventual fate.

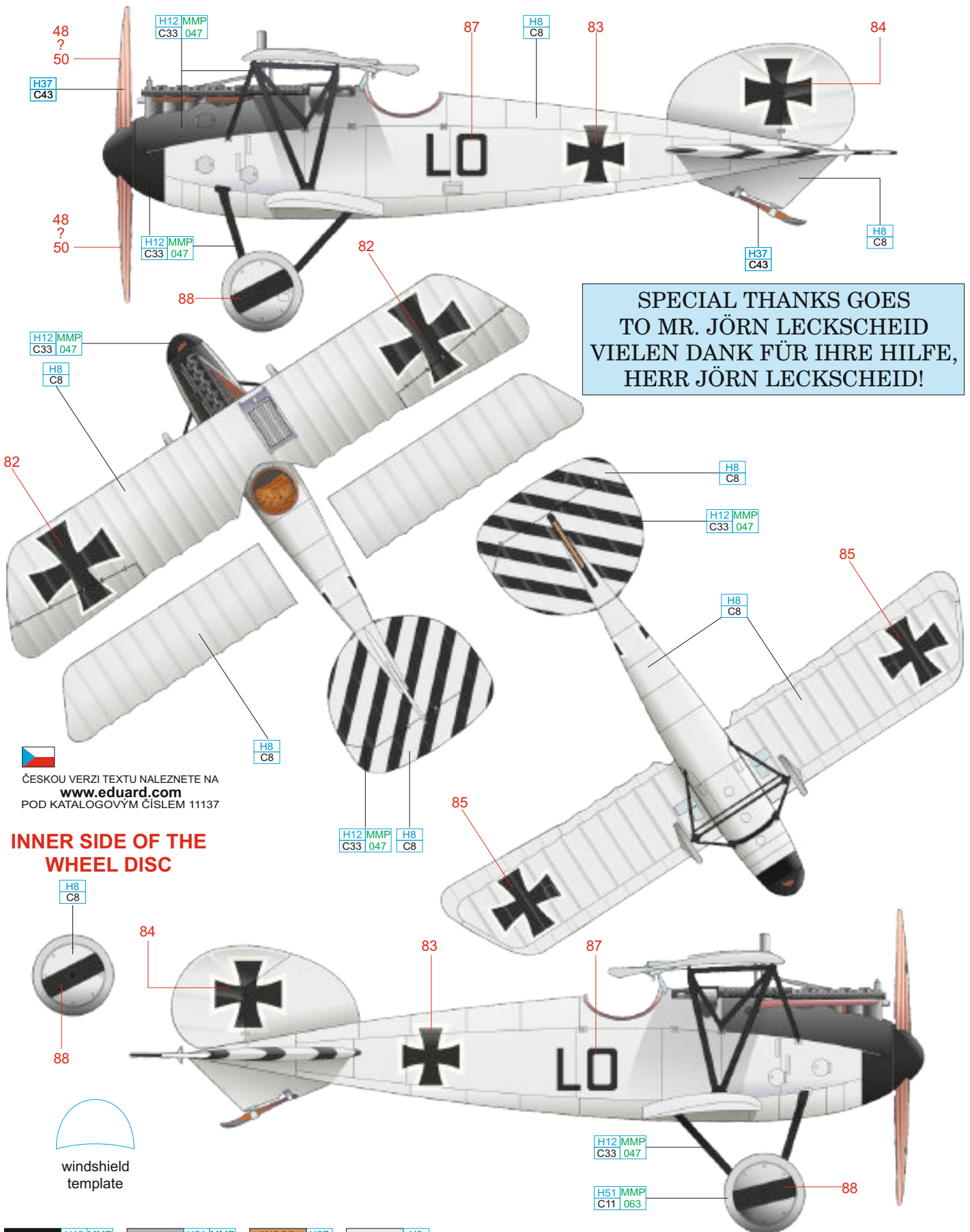

SPECIAL THANKS GOES TO MR. JÖRN LECKSCHEID  
 VIELIEN DANK FÜR IHRE HILFE,  
 HERR JÖRN LECKSCHEID!



ČESKOU VERZI TEXTU NALEZNETE NA  
[www.eduard.com](http://www.eduard.com)  
 POD KATALOGOVÝM ČÍSLEM 11137

## INNER SIDE OF THE WHEEL DISC

windshield template

BLACK	H12 MMP C33 047	GRAY	H51 MMP C11 063	WOOD BROWN	H37 C43	SILVER	H8 C8
-------	-----------------	------	-----------------	------------	---------	--------	-------

# B Albatros D.V, 4476/17, Jasta 37, Phalempin Airfield, France, September 1917

The silver Albatros D.V was followed by a second machine of the same type that appeared in a less spectacular finish. Albatros D.V 4476/17 retained its wooden fuselage factory finish, with just the "LO" marking applied, this time located a bit closer to the fuselage cross. The personal marking now received the addition of a white outline to give it a three-dimensional appearance. At one time, a telescopic gunsight was fitted, as was a taller than usual windscreen. Both these features were not seen again on one of his known later aircraft – and Udet certainly did not need a tall windscreen on any of his planes! The wings of this machine were covered in five-colour aircraft fabric (Flugzeugstoff), on both surfaces. Again, the fate of this plane is not known. It was either destroyed in a crash or handed down to a new pilot and re-painted, both these cases were quite common.

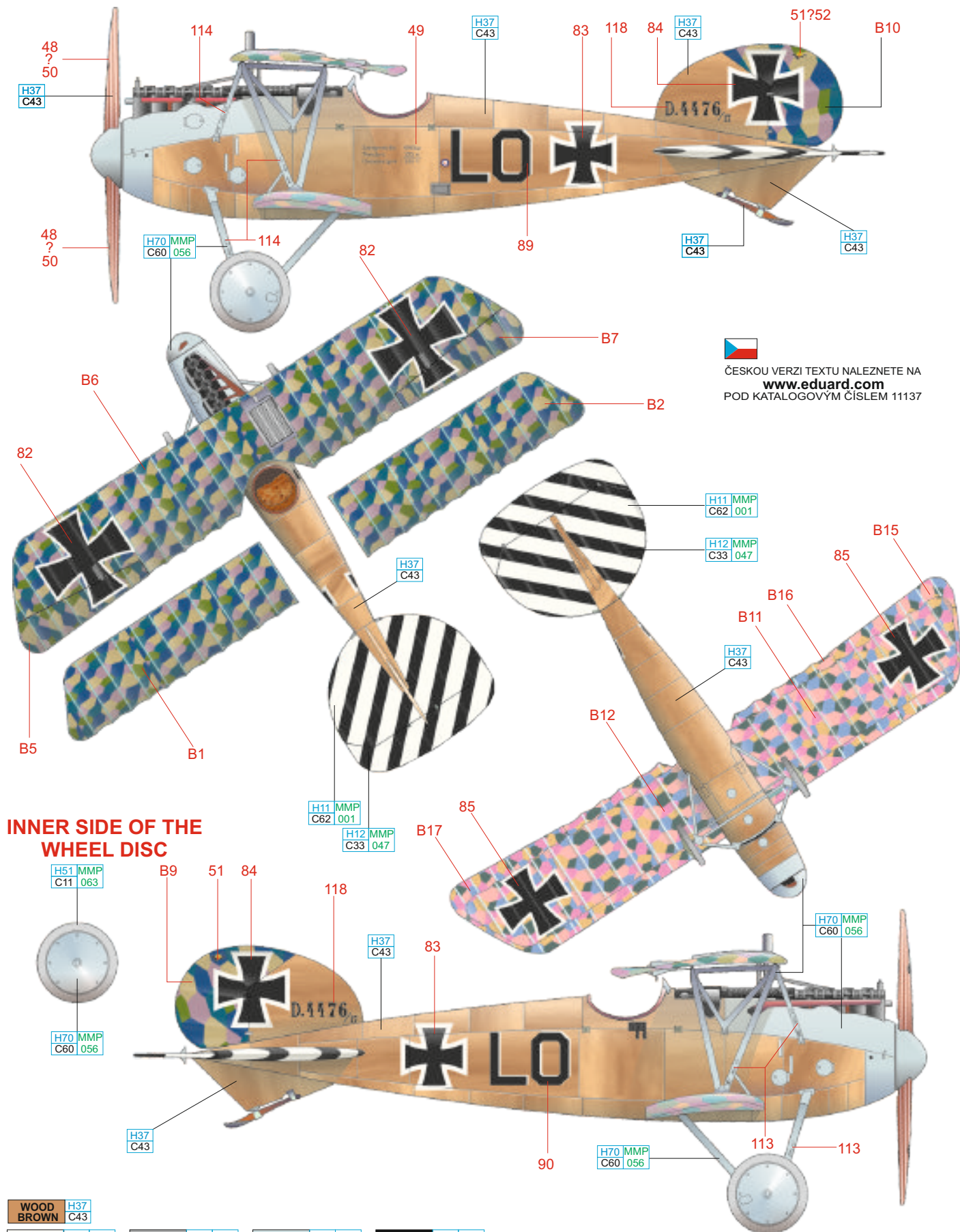

ČESKOU VERZI TEXTU NALEZNETE NA  
[www.eduard.com](http://www.eduard.com)  
 POD KATALOGOVÝM ČÍSLEM 11137

## INNER SIDE OF THE WHEEL DISC



WOOD BROWN	H37 C43	GRAY	H51 MMP C11 063	GRAY	H70 MMP C60 056	BLACK	H12 MMP C33 047
WHITE	H11 MMP C62 001						

# C Albatros D.Va, Jasta 37, Wynghenge Airfield, France, late 1917/early 1918

Udet was named commander of Jasta 37 on November 07th, 1917, when the previous Jasta commander Oblt. Kurt Grasshoff was posted away to lead Jasta 37. In his new position he flew this black-fuselaged D.Va in the winter of 1917/18. The chevron marking on the nose was applied in an interesting position. On all three of his known Albatros fighters in this unit the "LO" was applied in an angular manner. The lower wings of this machine were covered in five-colour aircraft fabric (Flugzeugstoff), while the upper surfaces were most likely painted in the usual two-tone camouflage. This mix was seen on at least one other Jasta 37 Albatros fighters, too. Two White "stripe" markings can be seen on the leading edge of the upper wing in photos, and we have interpreted this as two chevrons similar to the ones on the nose. Unfortunately, no clear view showing the top surface of the upper wing is known. One day, possibly an icy winter day in February 1918, this machine turned over on its back, most likely during a failed landing attempt. Udet would remain with Jasta 37 until March 8th, 1918, when he posted away, to join the most famous Jasta of them all, Manfred von Richthofen's Jasta 11. Udet was named commander of Jasta 37 on November 7th, 1917, when the previous Jasta commander Oblt. Kurt Grasshoff was posted away to lead Jasta 37. He would remain in that position until March 18th, 1918, when Udet in turn was posted away, to the most famous Jasta of them all, Manfred von Richthofen's Jasta 11.

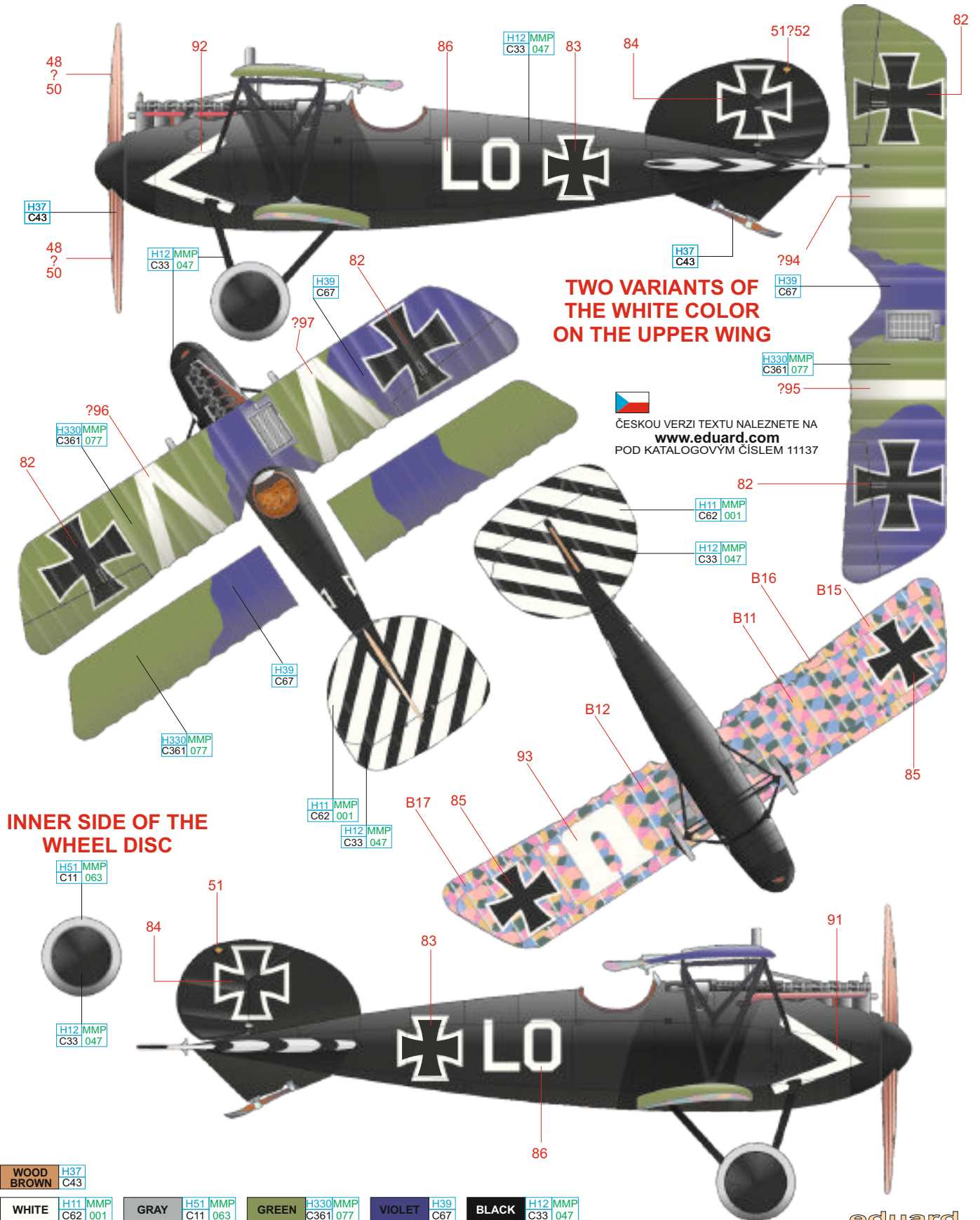

# D Fokker Dr.I, 586/17, Jasta 4, Airfield "La Ferme Puisieux" near Laon, France, late May 1918

After a few short weeks of flying with Jasta 11, Udet developed an ear infection and was sent home to Munich on April 8th, 1918 to recover. He only returned to JG I on May 22nd, and was then given command of Jasta 4. Previously, Jasta 6 ace Lt. Hans Kirschstein had acted as deputy commander of Jasta 4, but he returned to Jasta 6 when they re-equipped with the Fokker D.VII on May 15th, 1918. Kirschstein had painted his plane in alternating oblique black and white stripes on the fuselage and upper wing to throw off the aim of a pursuer. He called his planes in that marking "Die optische Täuschung" (the optical illusion). The stripes on the tail were the unit marking of his parent unit, Jasta 6. Obviously he left his Triplane behind at Jasta 4, and it was taken up by Udet when he returned from Munich a week later. Udet simply added the famous "LO" to the fuselage sides to personalize the plane, but it would only serve him for a short time. The "O" of his personal marking has now become rounded, more changes to the design of this monogram would follow soon. At some point in late May or early June, one of the cylinders of the rotary engine detached while the engine was running, tearing apart the engine cowling and damaging the upper wing. National insignias on the wings were changed most likely during the early days of the June 1918.

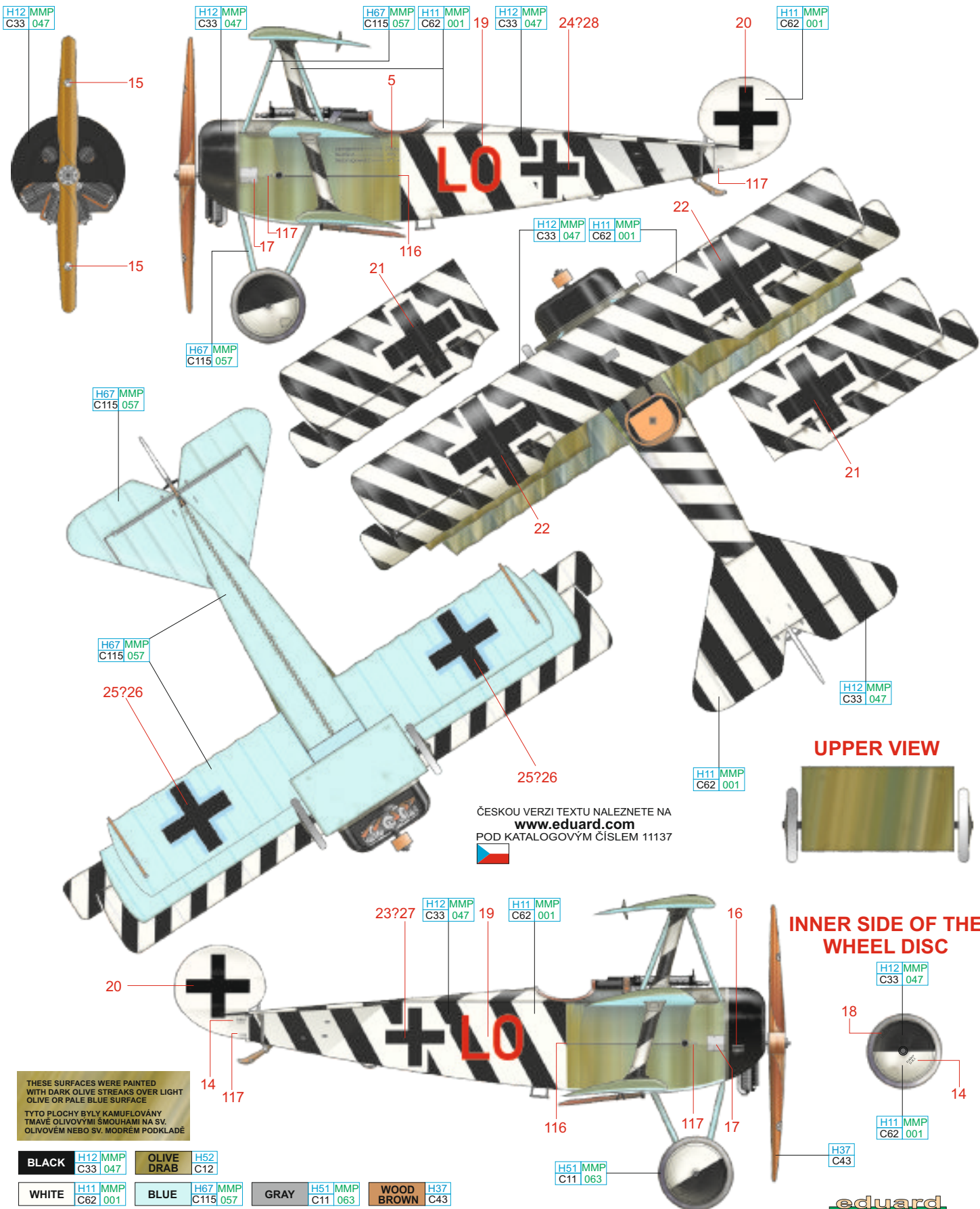

ČESKOU VERZI TEXTU NALEZNETE NA  
[www.eduard.com](http://www.eduard.com)  
 POD KATALOGOVÝM ČÍSLEM 11137



THESE SURFACES WERE PAINTED WITH DARK OLIVE STREAKS OVER LIGHT OLIVE OR PALE BLUE SURFACE  
 TYTO PLOCHY BYLY KAMUFLAGOVÁNY TMÁVĚ OLIVOVÝMI ŠMOUHAMI NA SV. OLIVOVĚM NEBO SV. MODRÉM PODKLADĚ

BLACK	H12 MMP C33 047	OLIVE DRAB	H52 C12
WHITE	H11 MMP C62 001	BLUE	H67 MMP C115 057
GRAY	H51 MMP C11 063	WOOD BROWN	H37 C43

# E Fokker Dr.I 593/17, Jasta 4, Beugneux-Cramoiselles Airfield, France, early June 1918

Jasta 4 had converted to the Fokker Dr.I on April 20th, 1918 while Udet was away from the front, and this was apparently a reserve Triplane that Udet used to replace the striped Triplane after it was damaged beyond repair. Photos show the plane in use at Jasta 4 in early June 1918 at Beugneux-Cramoiselles airfield. The chevron he had used previously in Jasta 37 on his Albatros D.Va re-appeared, on this Dr.I, now painted onto the horizontal tailplane. The outline of his „LO!“ marking had only been applied as a chalk outline on the fuselage sides, as a guide for the painter who would complete the marking later. No photo showing the „LO!“ marking actually applied to this plane is known. Apparently, not much effort was made to personalize the plane, Udet and his men were hoping to get the new D.VII soon.

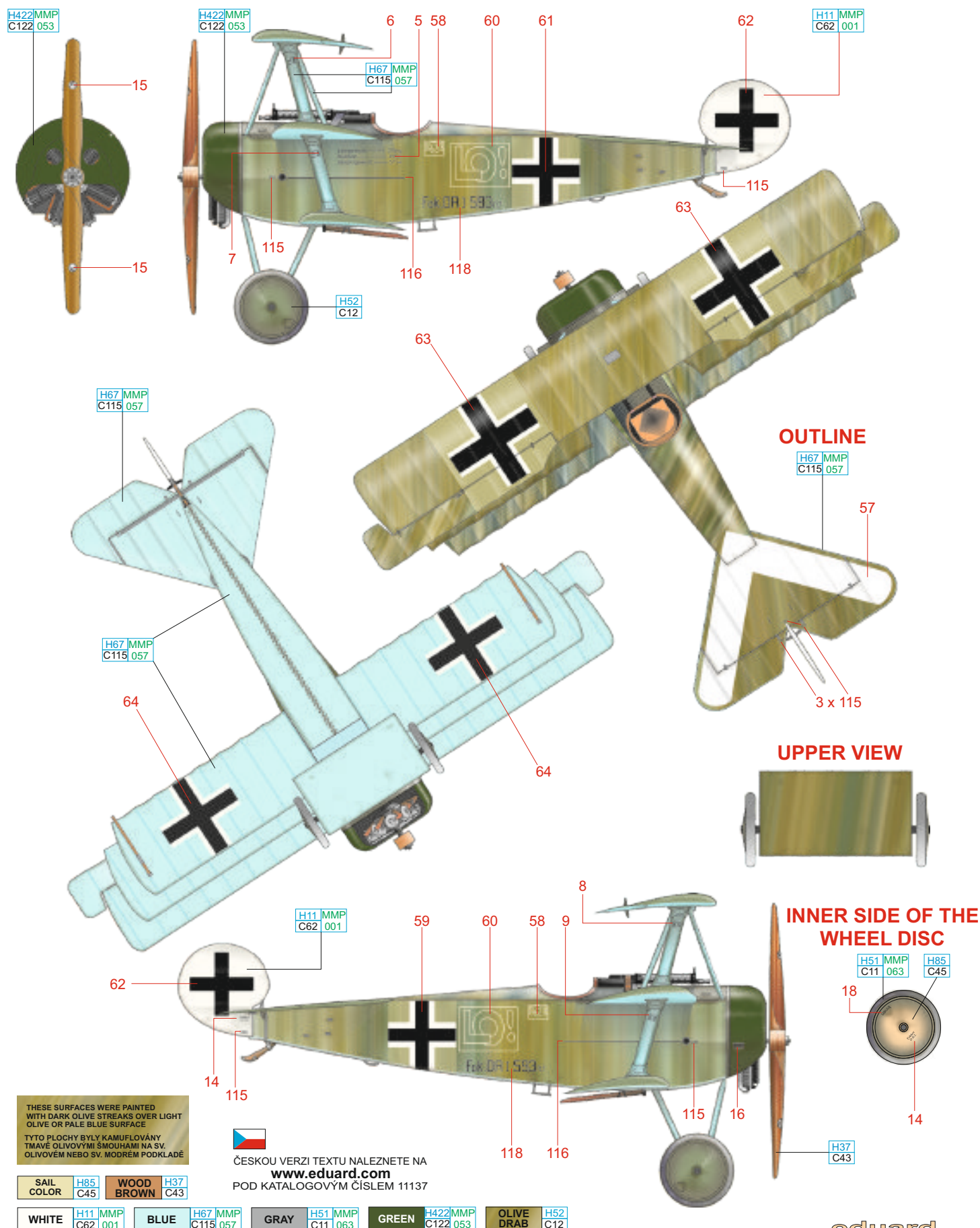

THESE SURFACES WERE PAINTED WITH DARK OLIVE STREAKS OVER LIGHT OLIVE OR PALE BLUE SURFACE  
 TYTO PLOCHY BYLY KAMUFLOVÁNY TMÁVĚ OLIVOVÝMI ŠMOUHAMI NA SV. OLIVOVĚM NEBO SV. MODRĚM PODKLADĚ

ČESKOU VERZI TEXTU NALEZNETE NA [www.eduard.com](http://www.eduard.com)  
 POD KATALOGOVÝM ČÍSLEM 11137

SAIL COLOR H85/C45 WOOD BROWN H37/C43

WHITE H11/MMP/C62/001 BLUE H67/MMP/C115/057 GRAY H51/MMP/C11/063 GREEN H422/MMP/C122/053 OLIVE DRAB H52/C12

# F Fokker D.VII (OAW), 20xx/18, Jasta 4, Beugneux-Cramoiselles Airfield, France, June 1918

Jasta 4 finally received the new Fokker D.VII on June 13th, 1918 – all these were license-built OAW machines, to replace their out-dated Triplanes. Immediately, a new unit marking, in the form of black noses, wheel covers and struts, was introduced. This marking was certainly inspired by the black fuselages of Jasta 37. Udet was named as the acting commander of Jagdgeschwader "Von Richthofen" on June 18th, and although he only held this position for one day, it was probably enough of an event to mark his plane in a more recognizable style. The fuselage was supposedly fully painted red, possibly as a reference to his previous service in Jasta 11. The wings were striped in red and white, similar to the Kirschstein plane, but with the stripes slanted in the opposite direction. The number of stripes is usually thought to be higher than we show here, but the famous photo of this plane is HEAVILY retouched, and close inspection reveals that only the stripe going through the right wing cross is original. All other stripes shown were simply drawn into the photo! By comparison with another tiny photo, shown in a TV documentary, we have come up with our interpretation of the upper wing stripe layout. The nose and wheel covers may have retained the black Jasta 4 unit markings, or were painted red as well. Available photos leave the possibility of both these options. Of course, this beautiful plane was lost on June 29th, 1918 in combat against a French Breguet Br. 14 observation plane.

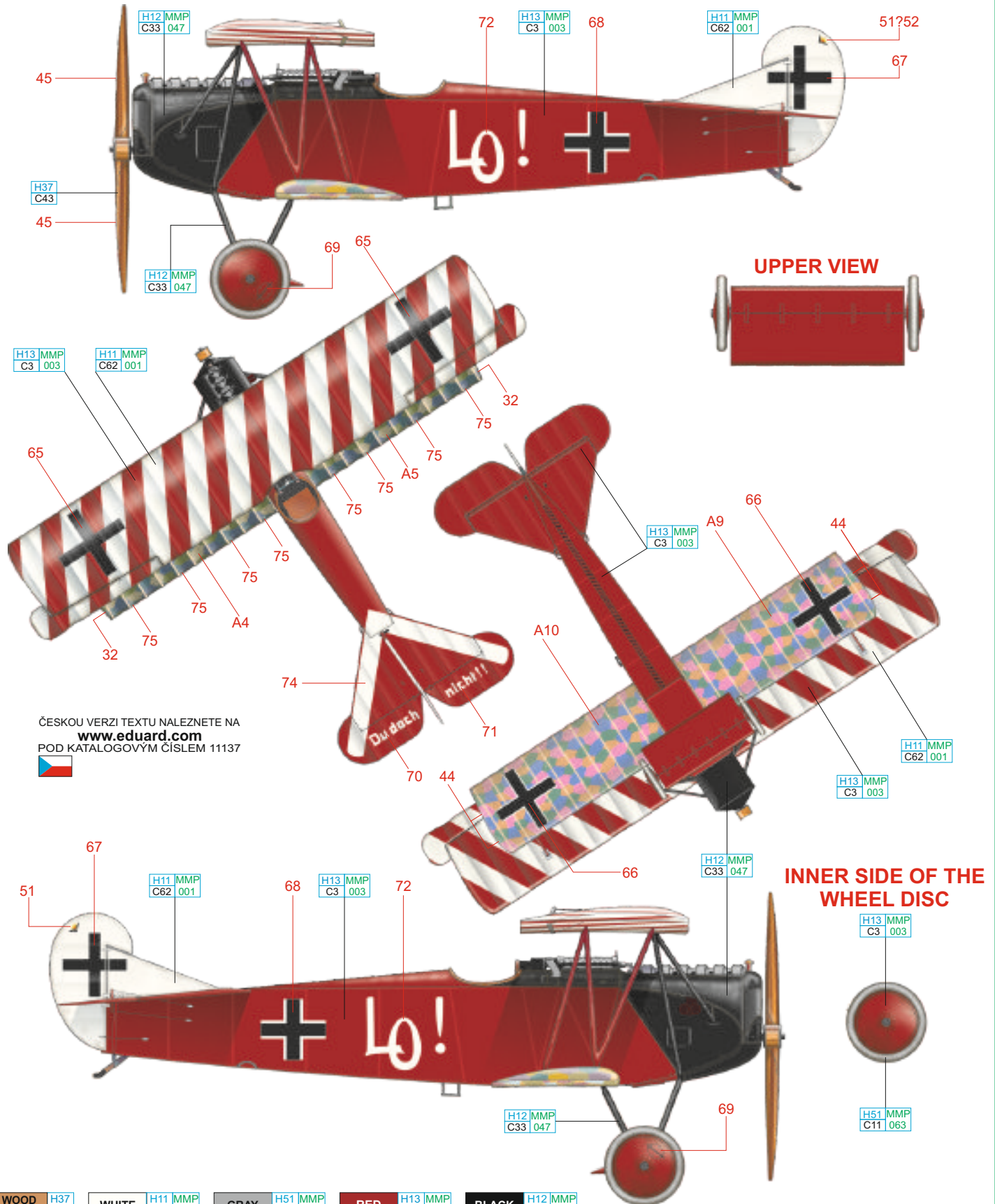

WOOD BROWN	H37 C43	WHITE	H11 MMP C62 001	GRAY	H51 MMP C11 063	RED	H13 MMP C3 003	BLACK	H12 MMP C33 047
------------	---------	-------	-----------------	------	-----------------	-----	----------------	-------	-----------------

# G Fokker D.VII (OAW), 20xx/18, Jasta 4, Airfield "La Ferme Puisieux" near Laon, France, August 1918

The photographs documenting the appearance of this plane were taken between late July and mid August 1918. Like "Du doch nicht!!" it was an early production OAW-built example, powered by a Mercedes engine and fitted with an Axial propeller. By this time, Udet very much preferred flying his Fokker-built D.VIIF powered by the BMW IIIa engine, which he very much preferred over the less powerful Mercedes. Most likely, this was the reserve plane he flew the day after "Du doch nicht!!" was lost, and kept it as a backup plane in case his D.VIIF was undergoing maintenance, and was not ready for immediate use. The fuselage and wings were covered with the four-colour variant of the aircraft fabric (Flugzeugstoff) that is usually called "Lozeng fabric". The wing rib tapes of early production OAW-built D.VII's were supposedly of natural linen fabric to use up existing stock of unprinted linen material.

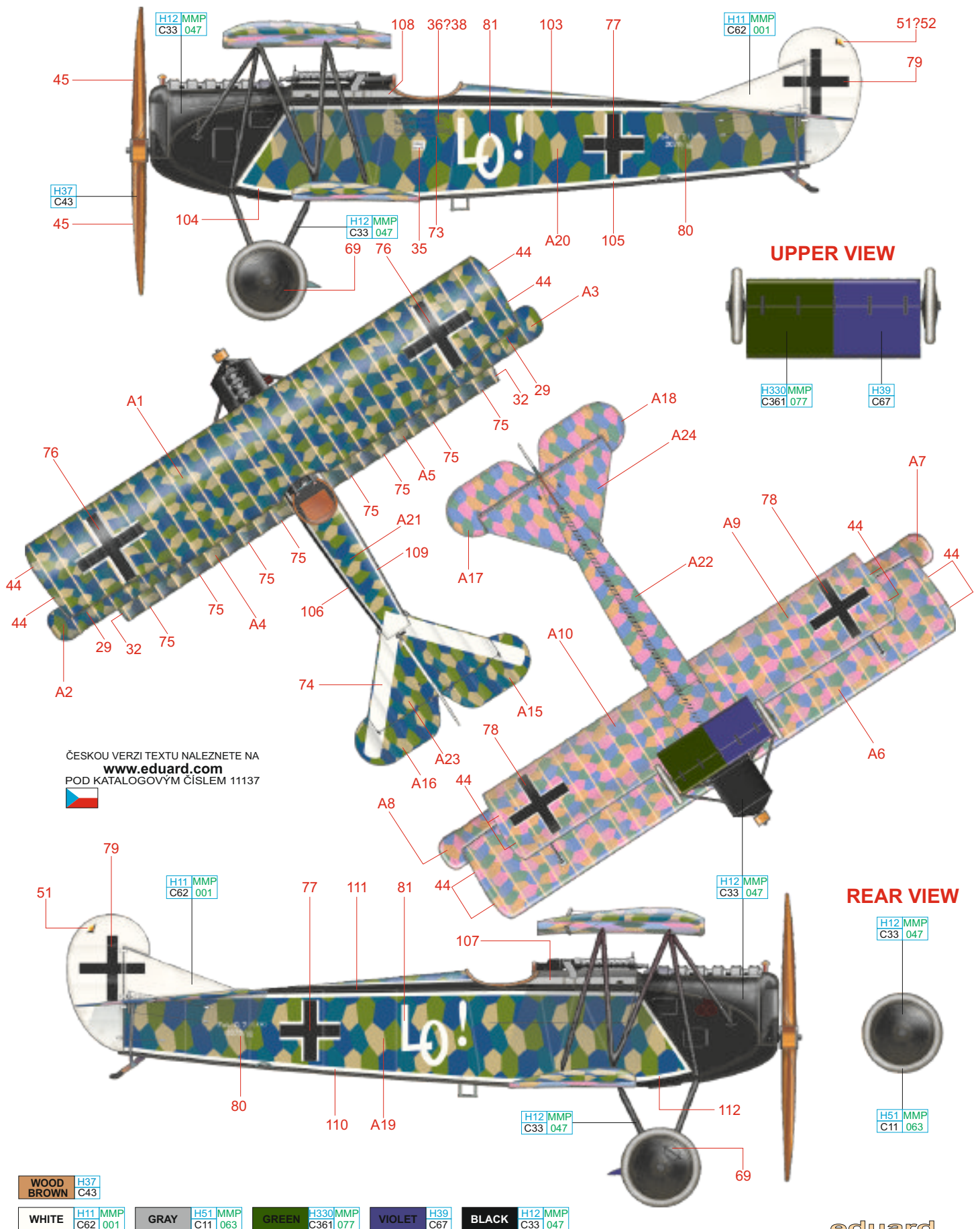

ČESKOU VERZI TEXTU NALEZNETE NA [www.eduard.com](http://www.eduard.com)  
POD KATALOGOVÝM ČÍSLEM 11137



