

T-6 TEXAN & U. S. NAVY

AVION ARGENT MAT.
MATT SILVER AIRCRAFT.

PAS DE MÂTS D'ANTENNE, VERRIÈRE
COMPLÈTE, TOUS MONTANTS.
NO ANTENNA MASTS,
FULL FRAMED CANOPIES.

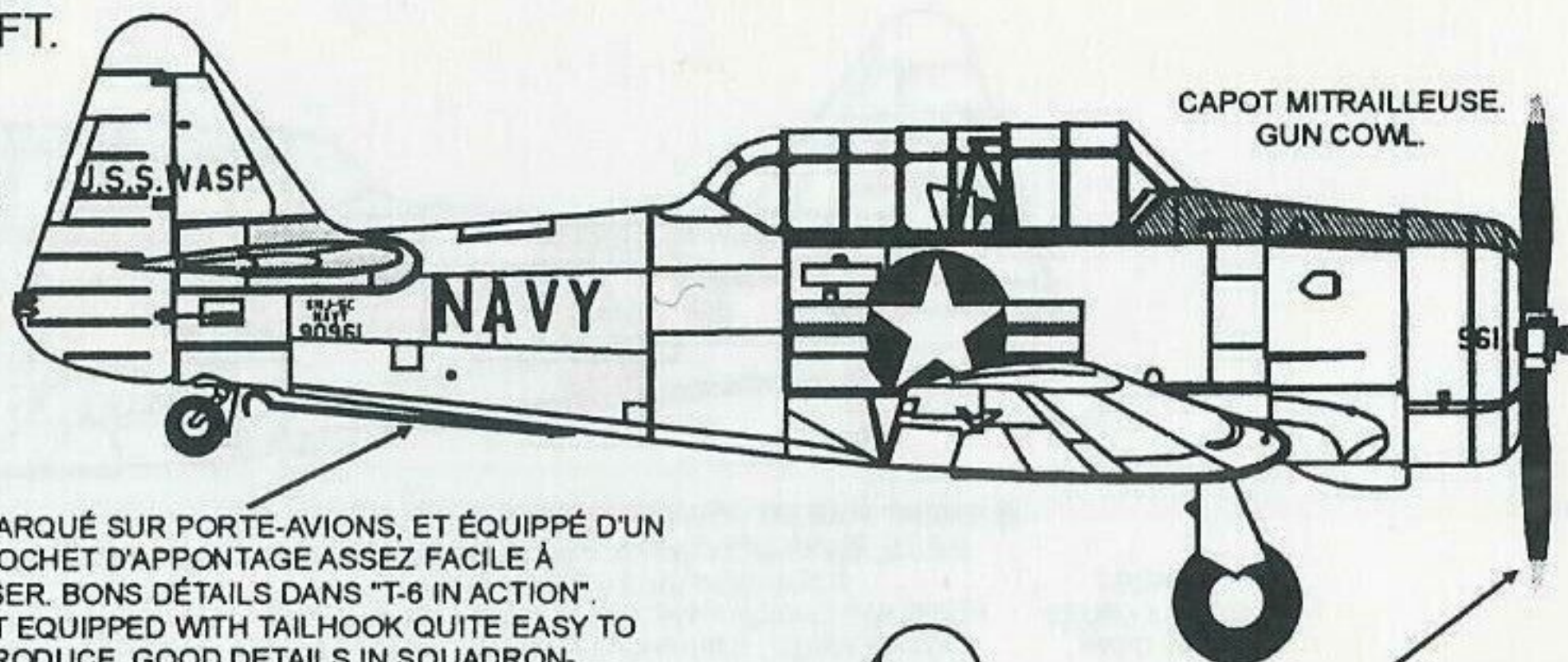

CAPOT MITRAILLEUSE.
GUN COWL.

AVION EMBARQUÉ SUR PORTE-AVIONS, ET ÉQUIPPÉ D'UN
CROCHET D'APPONTAGE ASSEZ FACILE À
RÉALISER. BONS DÉTAILS DANS "T-6 IN ACTION".
AIRCRAFT EQUIPPED WITH TAILHOOK QUITE EASY TO
REPRODUCE. GOOD DETAILS IN SQUADRON-
SIGNAL'S "T-6 IN ACTION".

CAPOT ANTI-REFLETS
VERT OLIVE Fs34087.
ANTI-DAZZLE PANNEL
OLIVE DRAP.

HÉLICE NOIRE,
POINTES JAUNE.
MATT BLACK PROP BLADES,
YELLOW TIPS.



COCARDES DE 18MM DE
DIAMÈTRE SUR FUSELAGE.
18MM DIAMETER NATIONAL INSIGNIAS
ON MID FUSELAGE POSITION.

ANTI-DÉRAPANTS SUR
RACINES D'AILES.
ANTI-SLIP PANNELS
ON WING ROOTS.

PAS DE CASSEROLE
D'HELICE.
NO DROP SPINNER.

TRAPPES DE ROUES
MONTÉES.
WHEEL DOORS
IN PLACE.

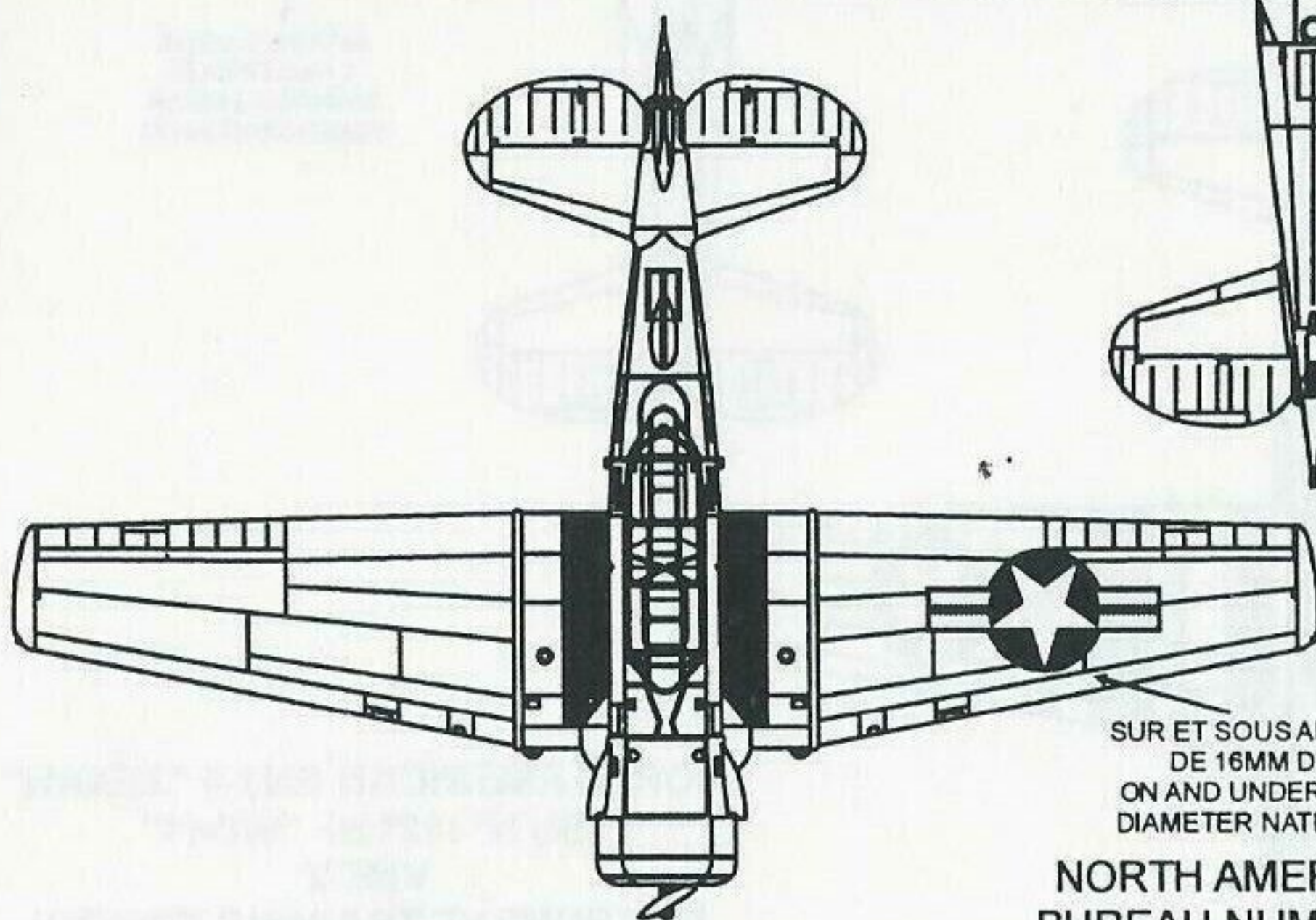
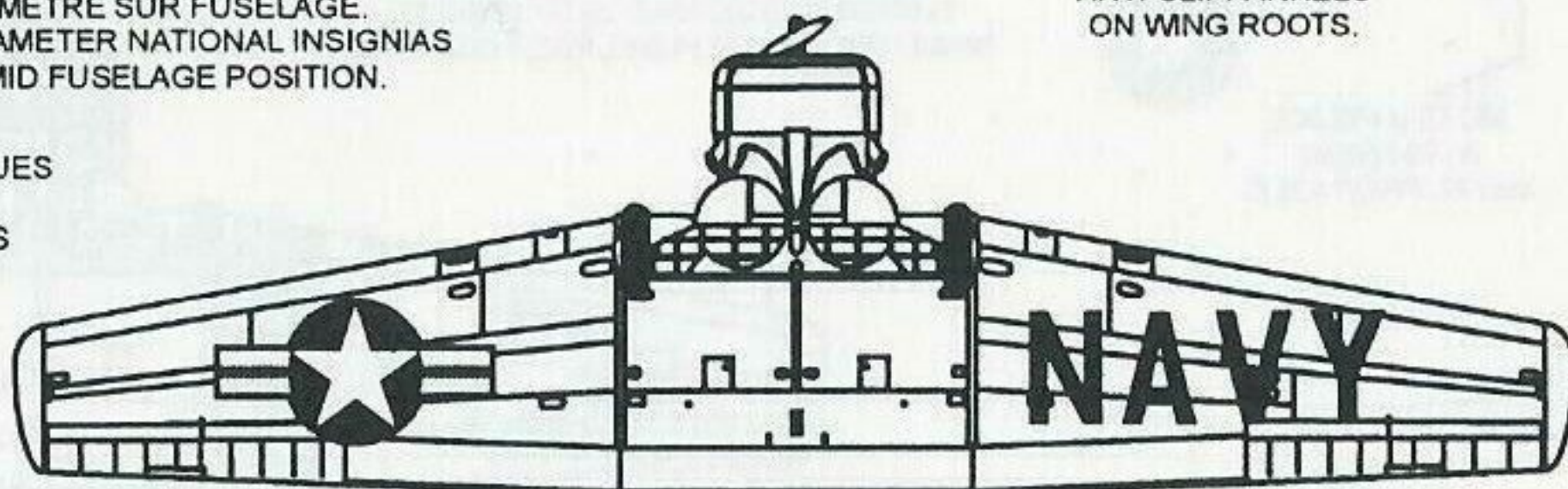

SUR ET SOUS AILES, COCARDES
DE 16MM DE DIAMÈTRE.
ON AND UNDER WING 16MM OF
DIAMETER NATIONAL INSIGNIAS.

L'AXE D'HÉLICE SEMBLE PEINT
D'UNE COULER SOMBRE.
PROP AXLE SEEMS TO BE PAINT
WITH A DARK COLOR.

NORTH AMERICAN SNJ-5C "TEXAN"
BUREAU NUMBER 90961 "USS WASP"
PORTE-AVIONS CV-18 USS WASP AIRCRAFT CARRIER
U.S. NAVY

1950

AVION ARGENT MAT AVEC TRACES LEGERES D'ECHAPPEMENT.
MATT SILVER AIRCRAFT WITH SLIGHT EXHAUST STAINS.

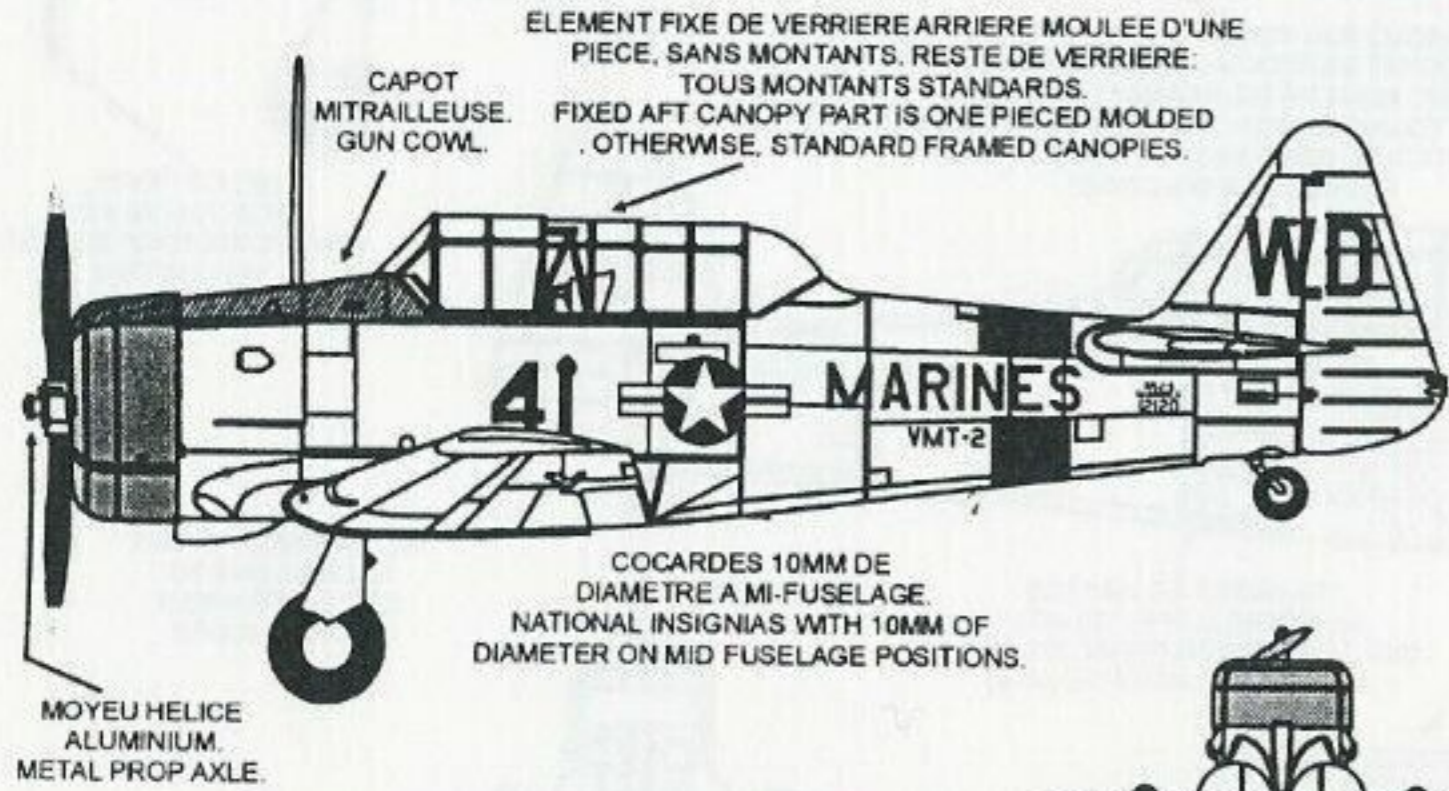
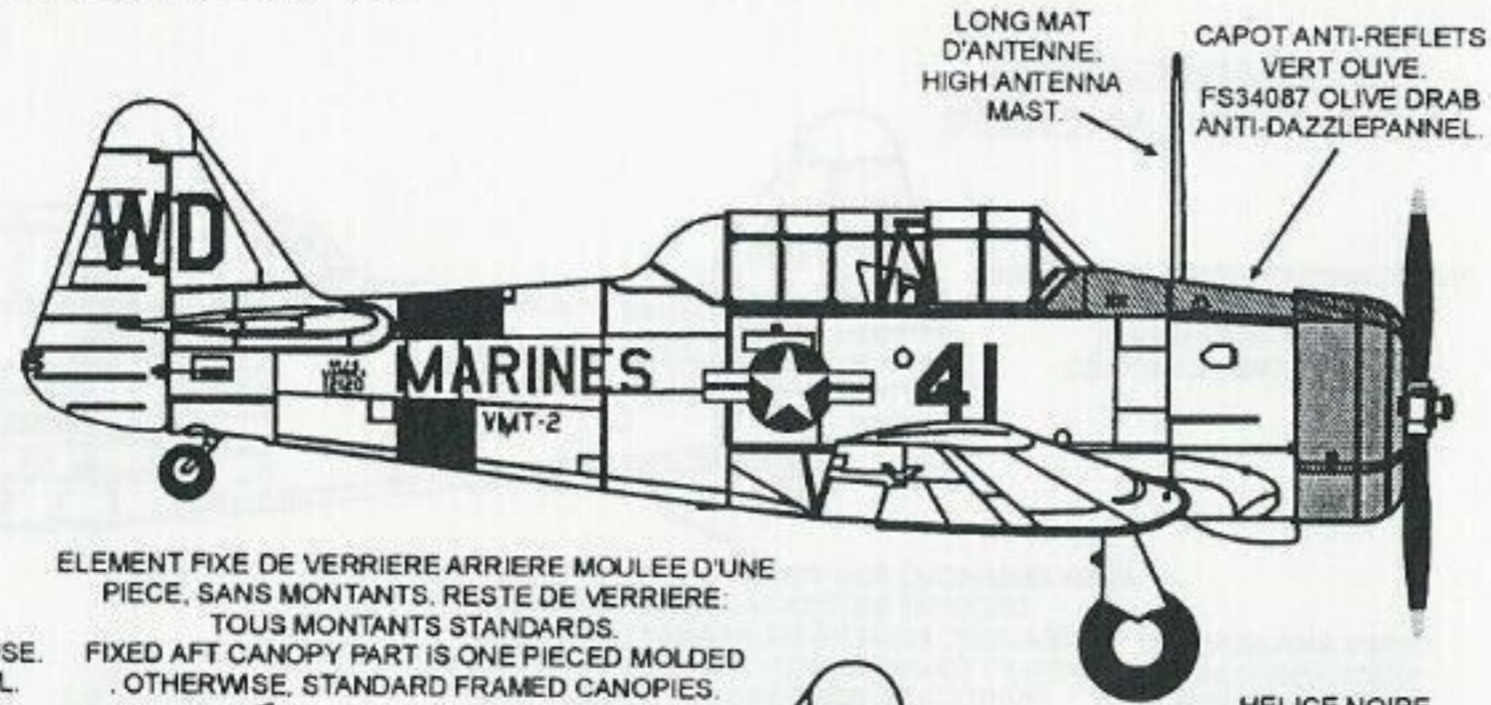

HELICE NOIRE, POINTES JAUNES. BLACK PROP. YELLOW TIPS.

CAPOT MOTEUR, BANDEAUX DE FUSELAGE ET AILES VERT MOYEN SIGNIFIANT ICI: ENTRAINEMENT AU PSV. ENGINE COWL, FUSELAGE AND WIN BANDS ARE LIGHT GREEN "WILLOW GREEN" FS34187.

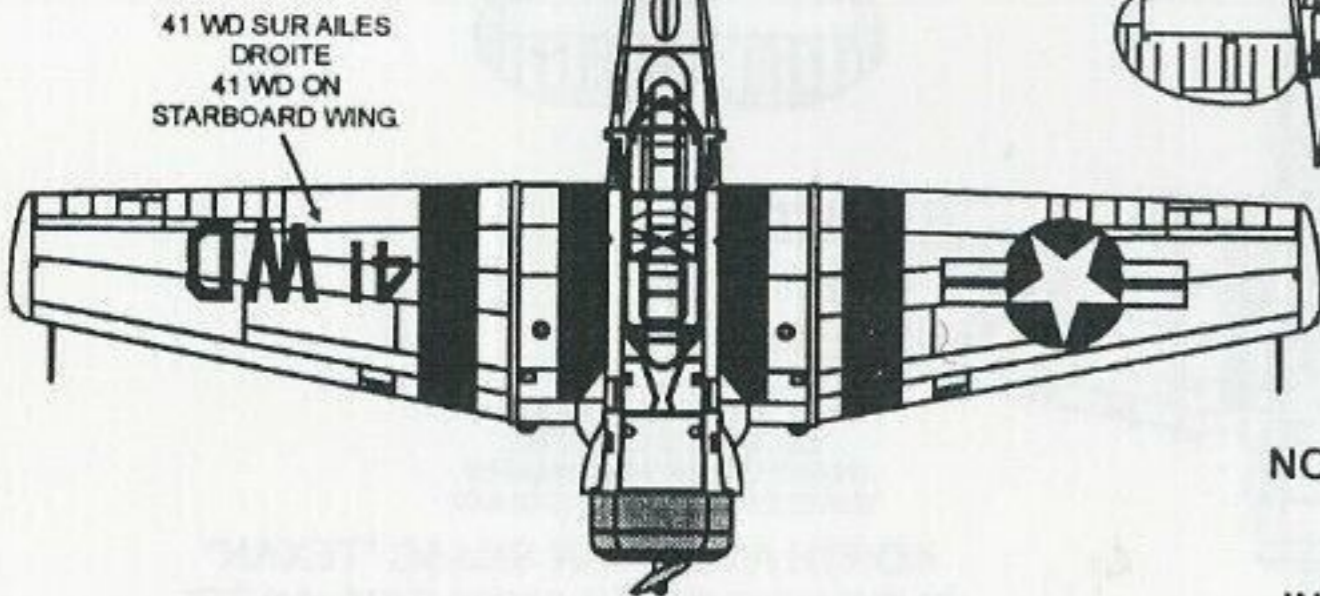
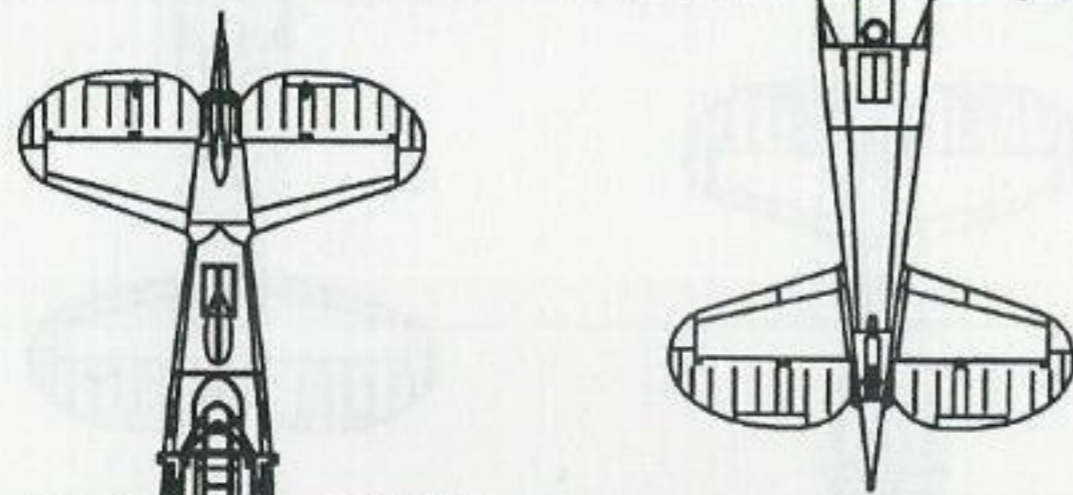
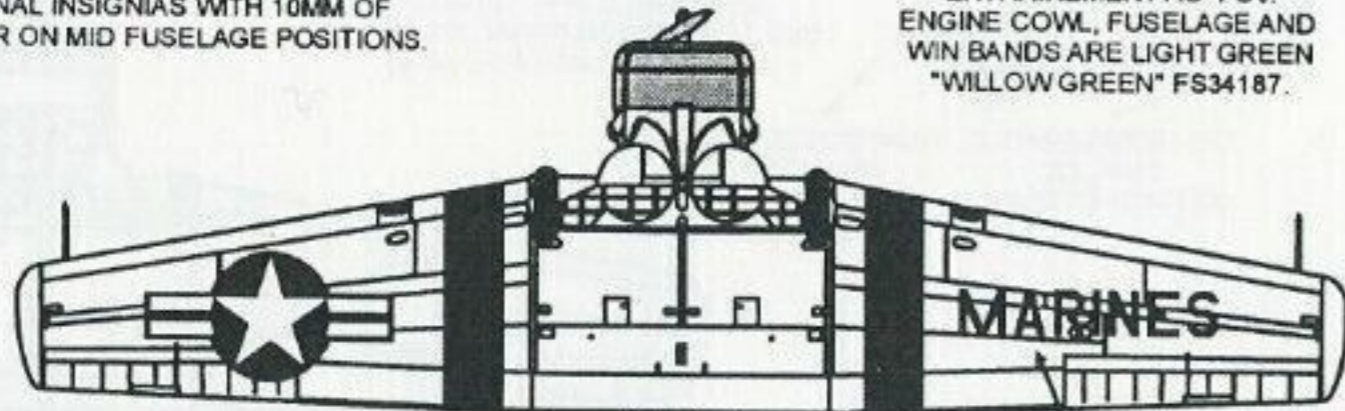

NORTH AMERICAN SNJ-6 "TEXAN"
BU N° :12120 "WD41"
VMT-2
INSTRUMENT TRAINING SCHOOL
MCAS EL TORO
CALIFORNIA + 1955
U.S. MARINE CORPS

AVION ARGENT MAT.
MATT SILVER AIRCRAFT.

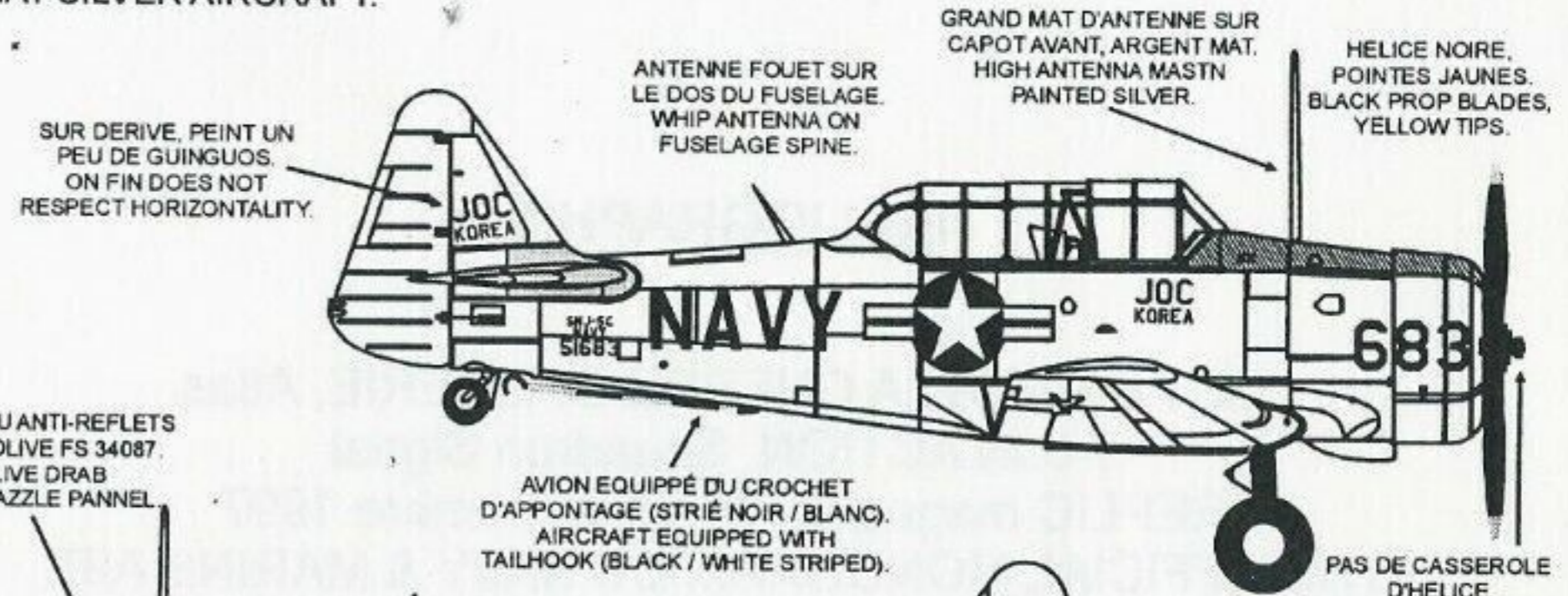

PANNEAU ANTI-REFLETS VERT OLIVE FS 34087. OLIVE DRAB ANTI-DAZZLE PANNEL.

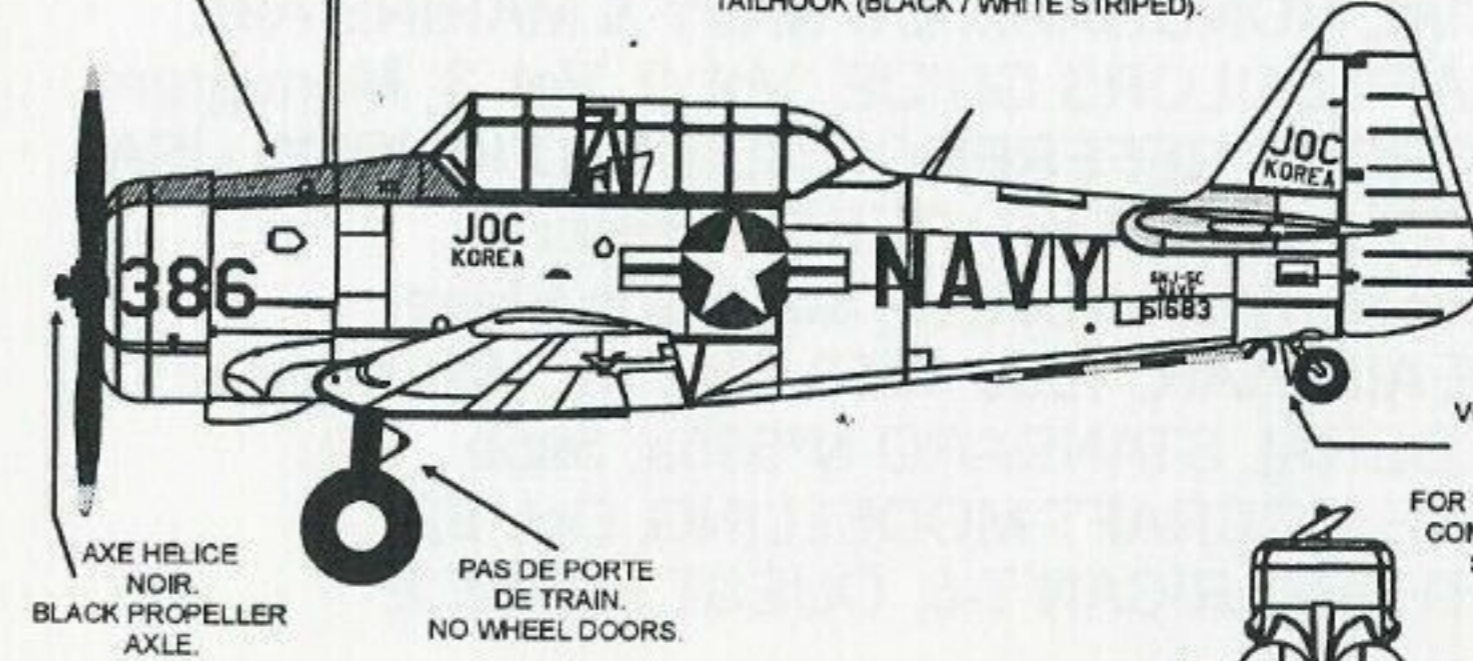

LA ROULETTE DU QUEUE DES SNJ EMBARQUES EST PROTEGEE D'UNE TOLE POUR EVITER L'ARRACHEMENT N CAS DE MAUVAIS APPONTAGE. VOIR "T-6 IN ACTION" POUR DETAILS. CARRIER BORNE SNJ'S HAVE A SPECIAL PROTECTION FOR THE TAILWHEEL, TO AVOID FUSELAGE COMING APART DURING BAD LANDINGS. SEE "T-6 IN ACTION" FOR DETAILS.

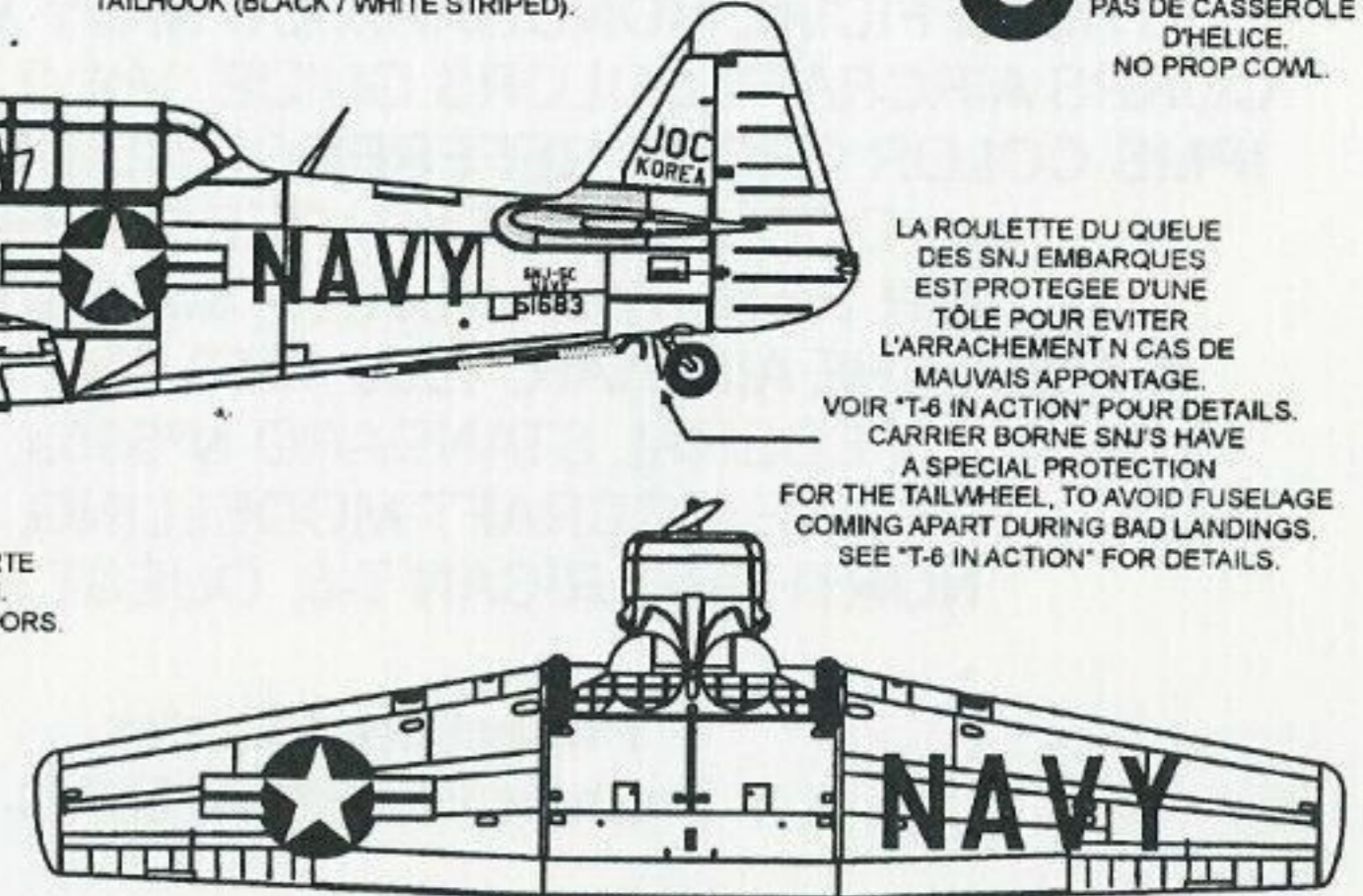

PANNEAUX ANTI-DERAPANTS EN PLACE SUR AILES. ANTI-SLIP PANNELS IN PLACE ON WING ROOTS.

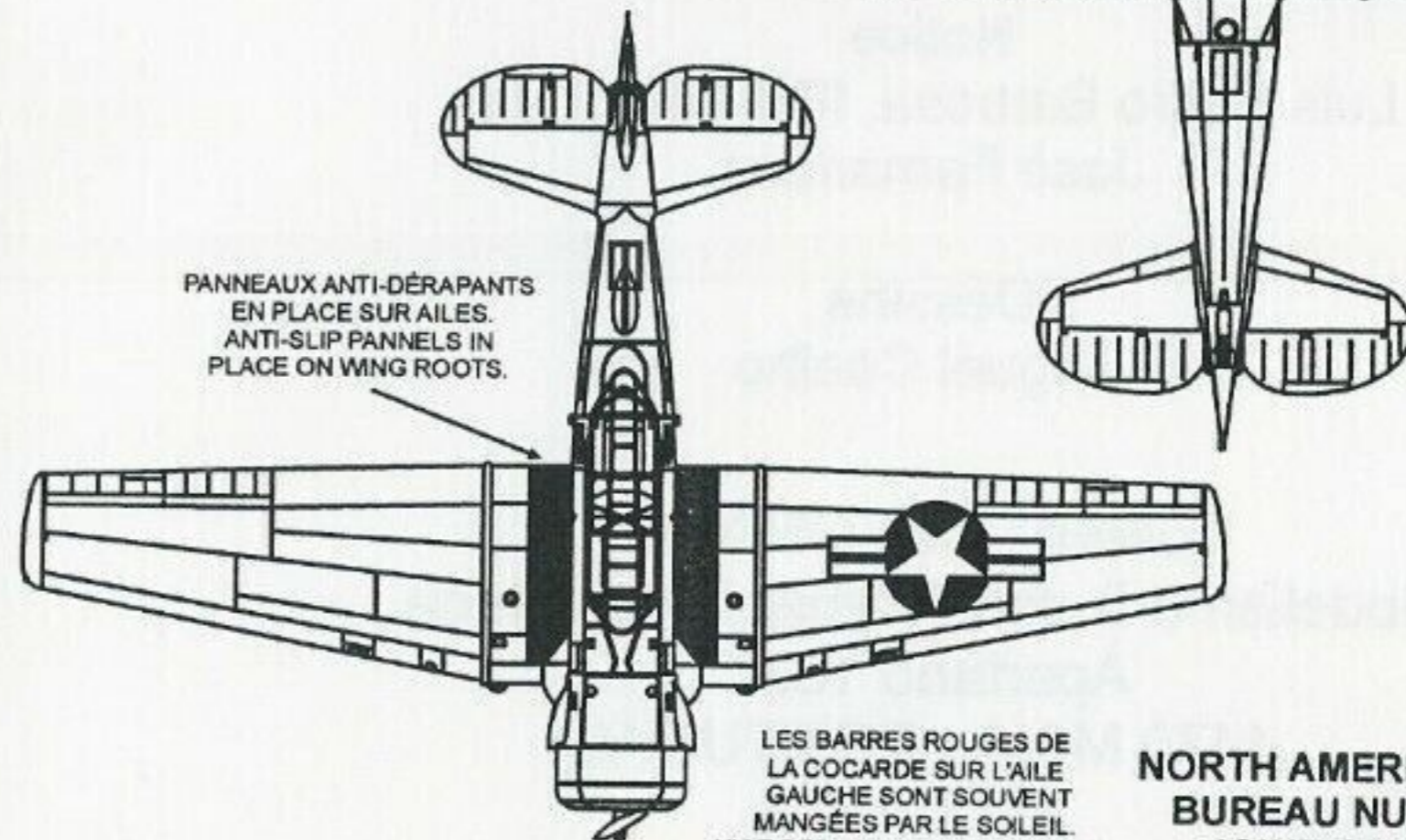

LES BARRES ROUGES DE LA COCARDE SUR L'AILE GAUCHE SONT SOUVENT MANGÉES PAR LE SOLEIL. NICE RED STRIPES ON NATIONAL INSIGNIA, OVER PORT WING, ARE MOST OF THE TIME FADED TO A PALE PINK.

NORTH AMERICAN SNJ-5C "TEXAN"
BUREAU NUMBER :51683 "JOC"
JOINT OPERATIONS CENTER
KOREA
LIAISON NAVY / 5TH AIR FORCE
VIP TRANSPORT ETC.1951

T-6 TEXAN & U. S. NAVY

BIBLIOGRAPHIE

LE T-6 DANS LA GUERRE D'ALGERIE, Atlas
T-6 IN ACTION, Squadron Signal
REPLIC magazine, N° 76, decembre 1997
THE OFFICIAL MONOGRAM US NAVY & MARINE AIR
CORPS AIRCRAFT COLORS GUIDE, Vol. 2, Vol. 3, Monogram
IPMS COLOR CROSS-REFERENCE GUIDE, D.K., IPMS USA
DOCUMENTATION PERSONNELLE
AIR WAR OVER KOREA, Squadron Signal
KOREA, THE AIR WAR, 1950-1953, Osprey, Vol. 1, Vol. 2
FEDERAL STANDARD N°595a, 595b
SCALE AIRCRAFT MODELLING, Oct. 82
NORTH AMERICAN T-6, OUEST FRANCE

Project coordinator
Freiherr von FINK, D.F.C

Notice
Luis Pedro Barbosa, IPMS Portugal
José Fernandes

Dessins
Miguel Coelho

Editeur : COLORADO
Modelismo & decalcomanias Limitada
Apartado 1037
4470 MAIA - PORTUGAL

Internet : <http://www.decalco.com/>

Email : colorado@decalco.com