



POLIKARPOV R-1

1:72
model # CP72026



ADVANCED
★ ★

scale model kit

SPAN: 194,74 mm ✪ LENGTH: 128,31 mm ✪ NUMBER OF PARTS: 360 pcs

1 stages of assembly	? optional
A variants of assembly	glue by super glue
A1 part number	do not glue
fill with putty	make a hole
1 apply decals	detach with knife
1 apply the adhesive mask	paint
bend	repeat the operation N times

Role Multi-purpose reconnaissance biplane
 National origin USSR
 Manufacturer Polikarpov
 Designer N.N. Polikarpov
 First flight August 1924
 Number built 2751 aircraft

P-1 is a two-seat reconnaissance aircraft created in 1924 in the USSR on the basis of the DH-9a aircraft, in the design bureau of N.N. Polikarpov. The design of the R-1 was not a direct copy of the British prototype but was an adaptation of one of the most successful aircraft of the First World War for this purpose to the capabilities of the nascent Soviet aircraft industry. R-1 became the first large-scale aircraft in the USSR, produced from 1924 to 1932 at two factories in Moscow and Taganrog. The total production of modifications R-1 (reconnaissance), R-2 (training version), MP-1 (float version), and P-1 (unarmed civilian version) amounted to 2751 copies. The first cars were equipped with the American Liberty-12 engine and since 1925 they installed its Soviet copy M-5. Aircraft of this type played an important role in the formation of the Red Army Air Force. The R-1 was used by the Soviet Air Force in the Sino-Soviet conflict on the CER in 1929. Civilian versions of the R-1 and R-2 participated in the international flight Moscow-Beijing-Tokyo in 1925. The R-1 was in service until the mid-1930s.

REQUIRED PAINTS

A A.MIG-0197 BRASS	B A.MIG-0199 COPPER	C A.MIG-0045 GUN METAL	D A.MIG-0194 ALUMINIUM	E A.MIG-0191 STEEL	F A.MIG-0204 MEDIUM GUNSHIP GREY	G A.MIG-0040 RUST	H A.MIG-0133 LEATHER	I A.MIG-0029 DESERT YELLOW	J A.MIG-0249 Allg LIGHT GRAY BLUE	K A.MIG-0031 KHAKI GREEN
L A.MIG-0091 VARNISH GLOSSY	M A.MIG-0054 SIGNAL GREEN	N A.MIG-0050 WHITE	O A.MIG-0064 EARTH BROWN	P A.MIG-0032 SATIN BLACK	R A.MIG-0033 RUBBER	S A.MIG-0038 LIGHT WOOD	T A.MIG-0058 GREEN KHAKI	 AMMO by MIG Jimenez		

THIS MODEL IS PRODUCED FOR EXPERIENCED MODELERS OVER 14 YEARS

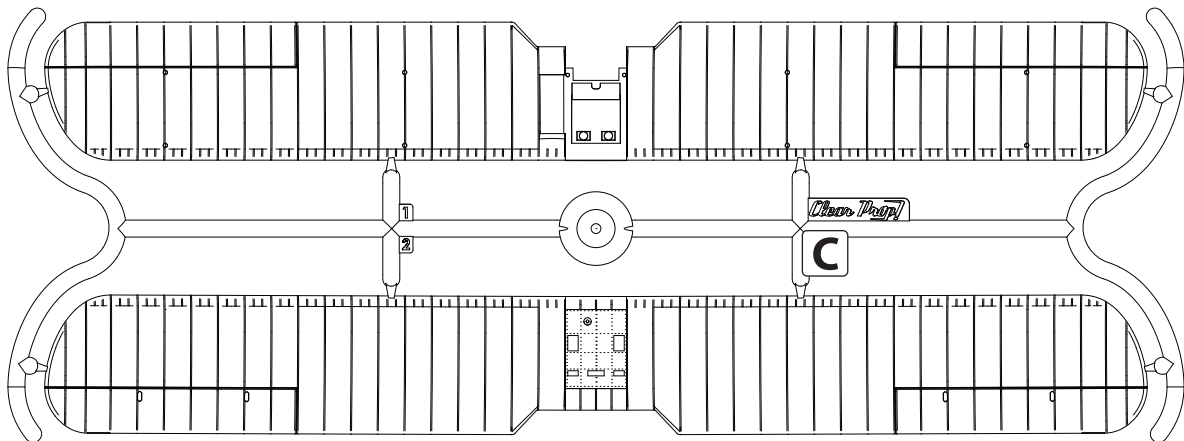
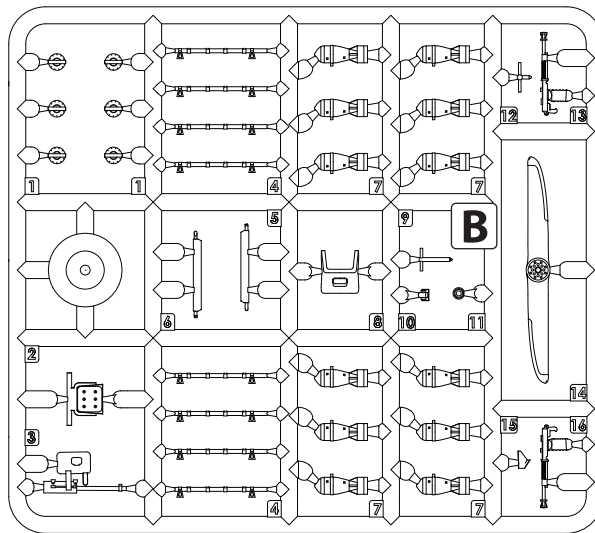
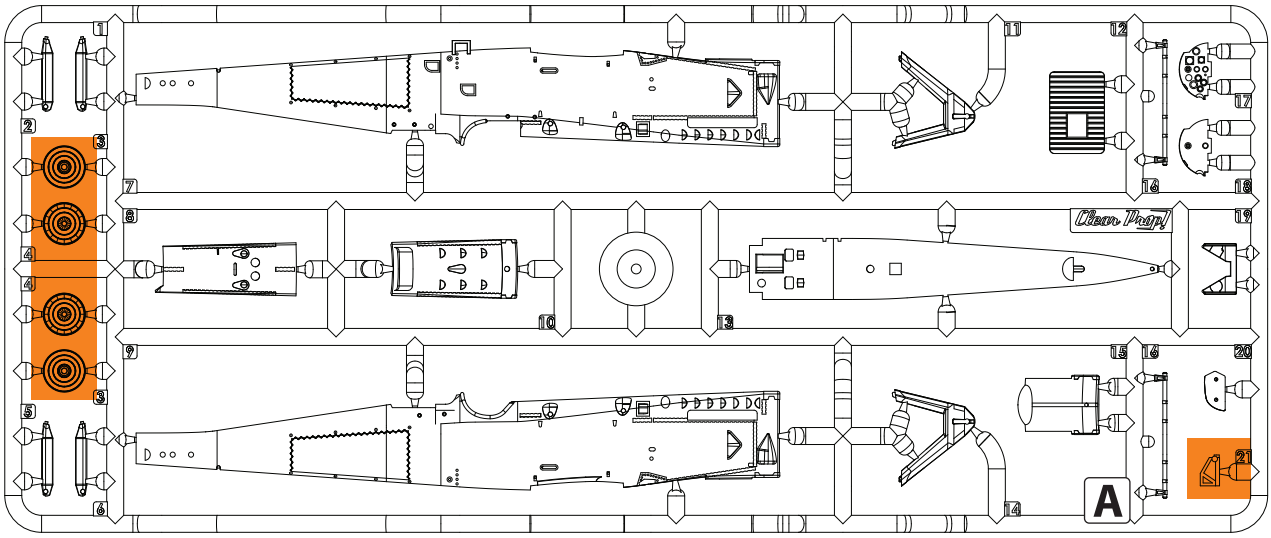

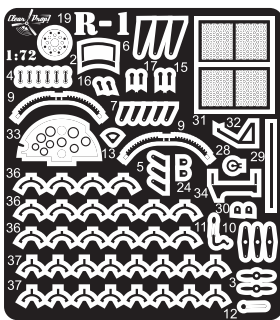
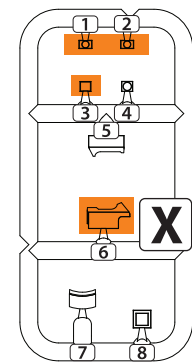
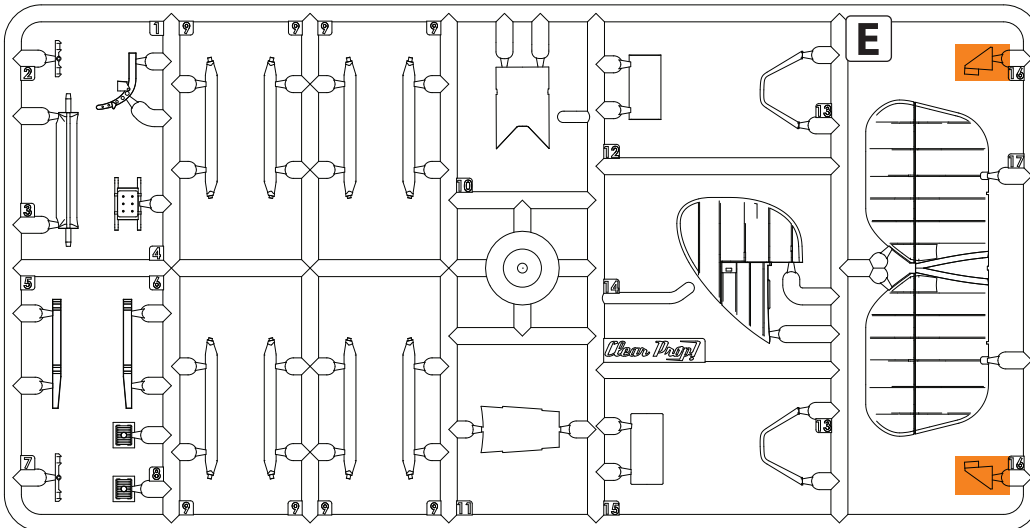
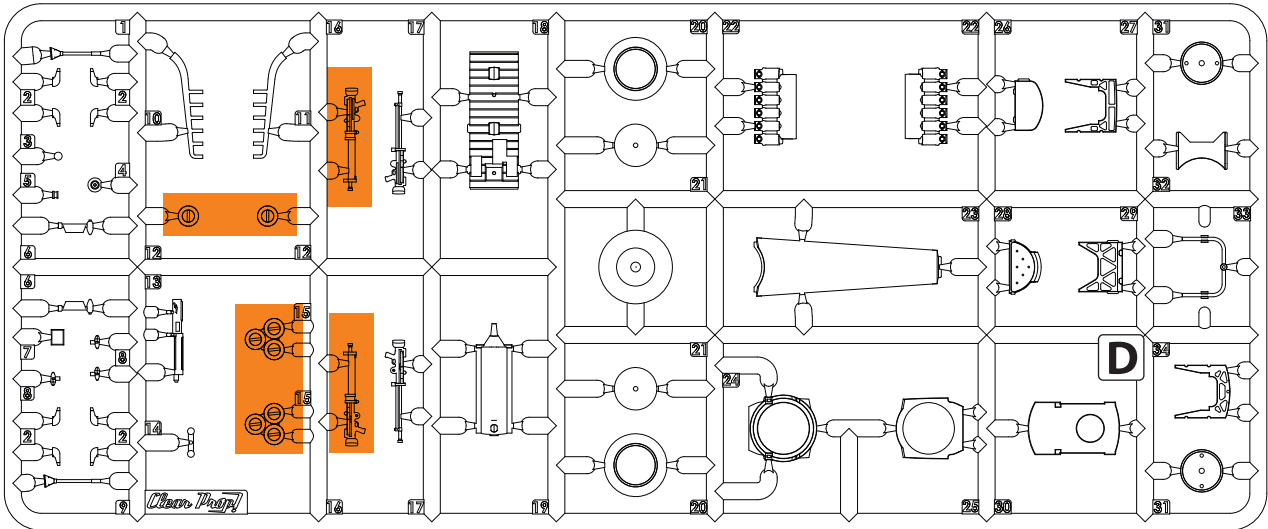

Parts not for use

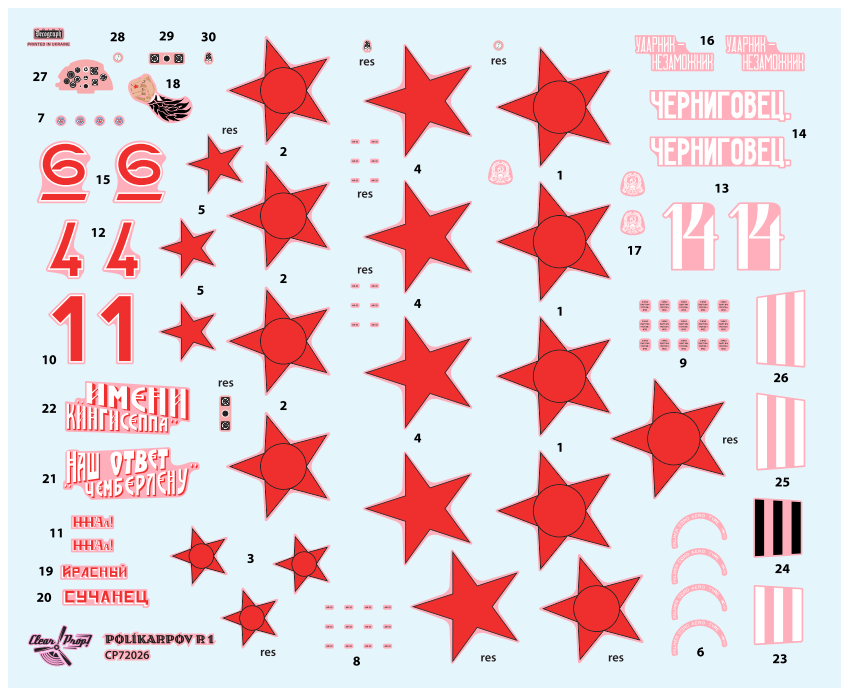

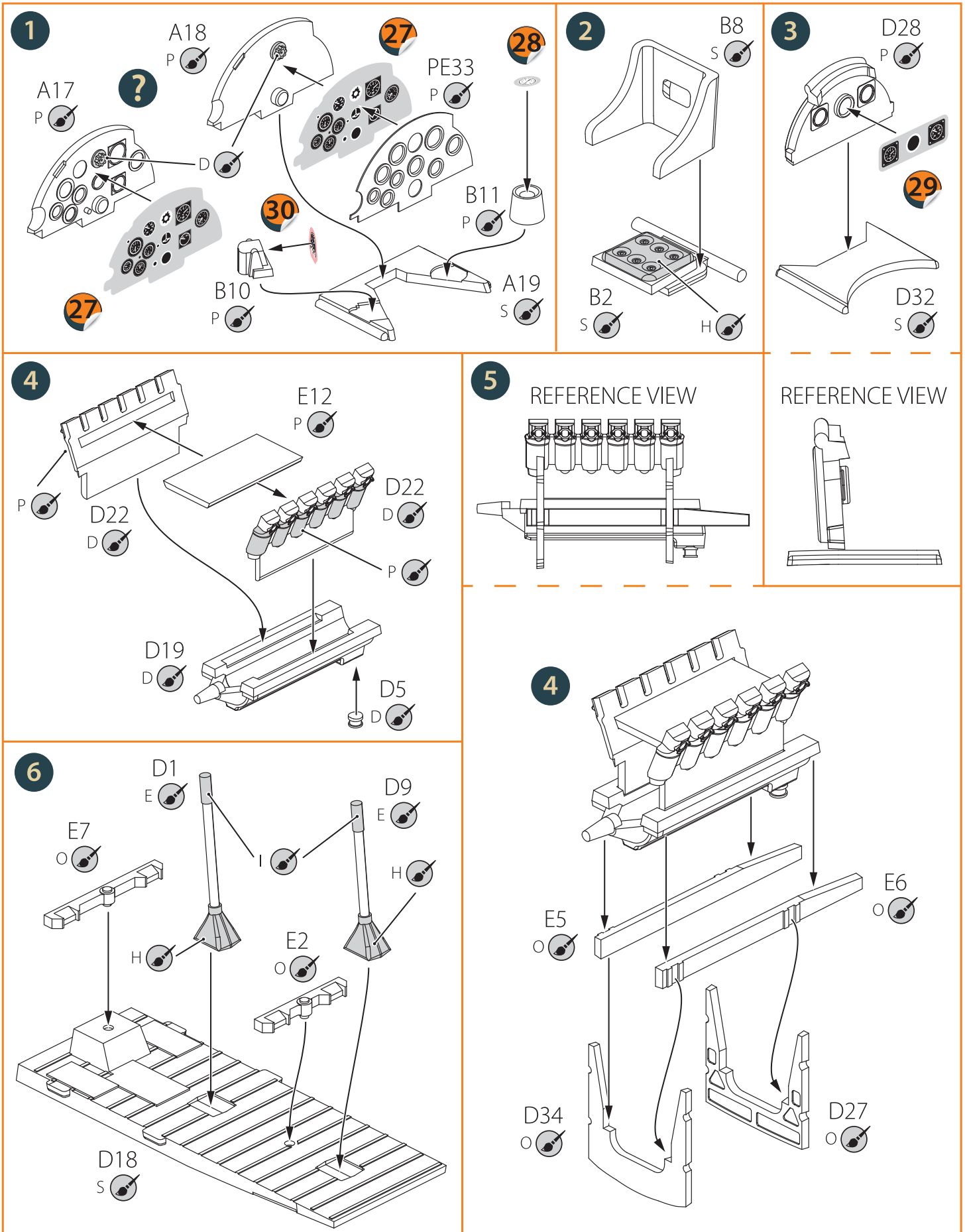

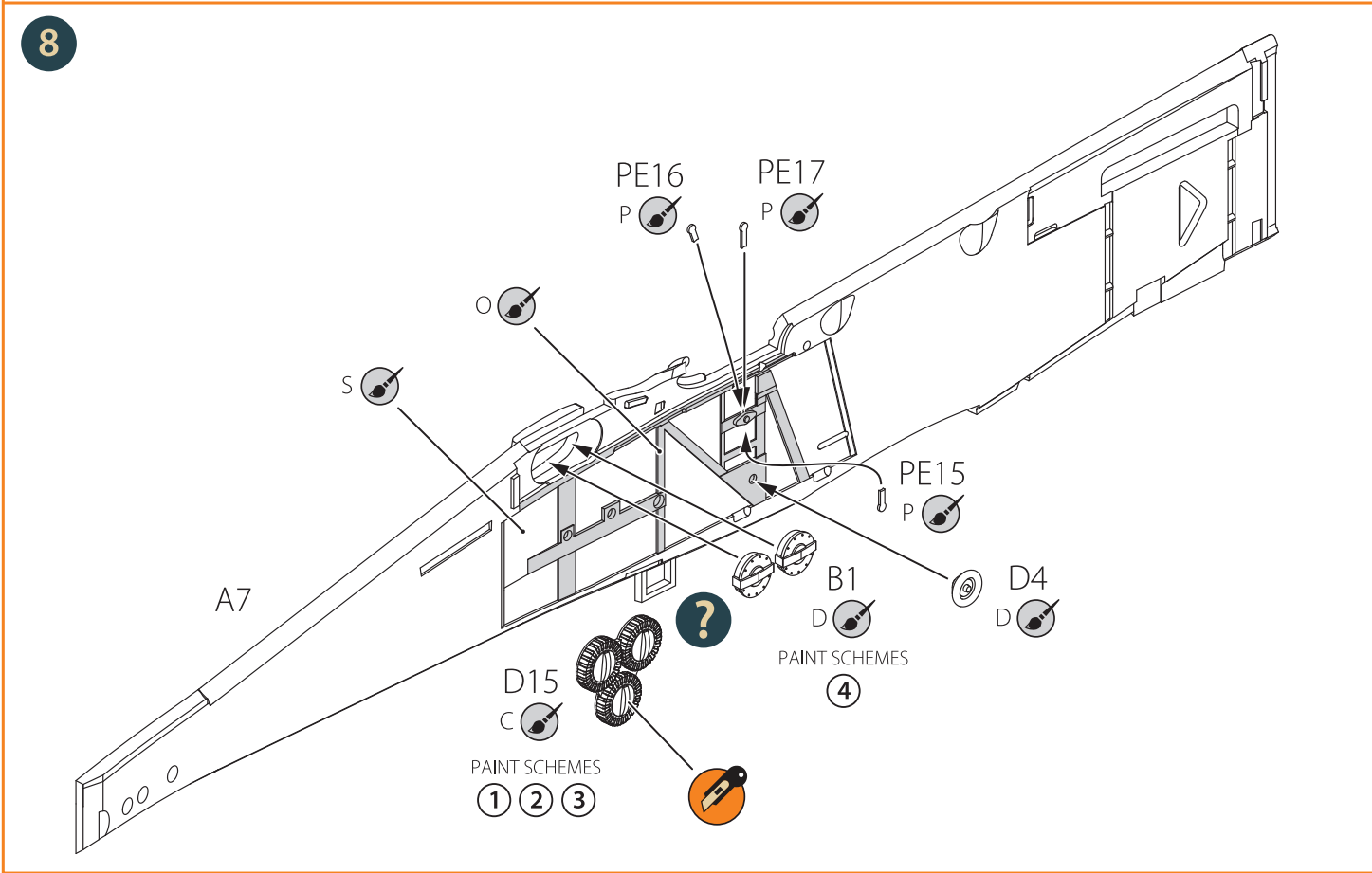
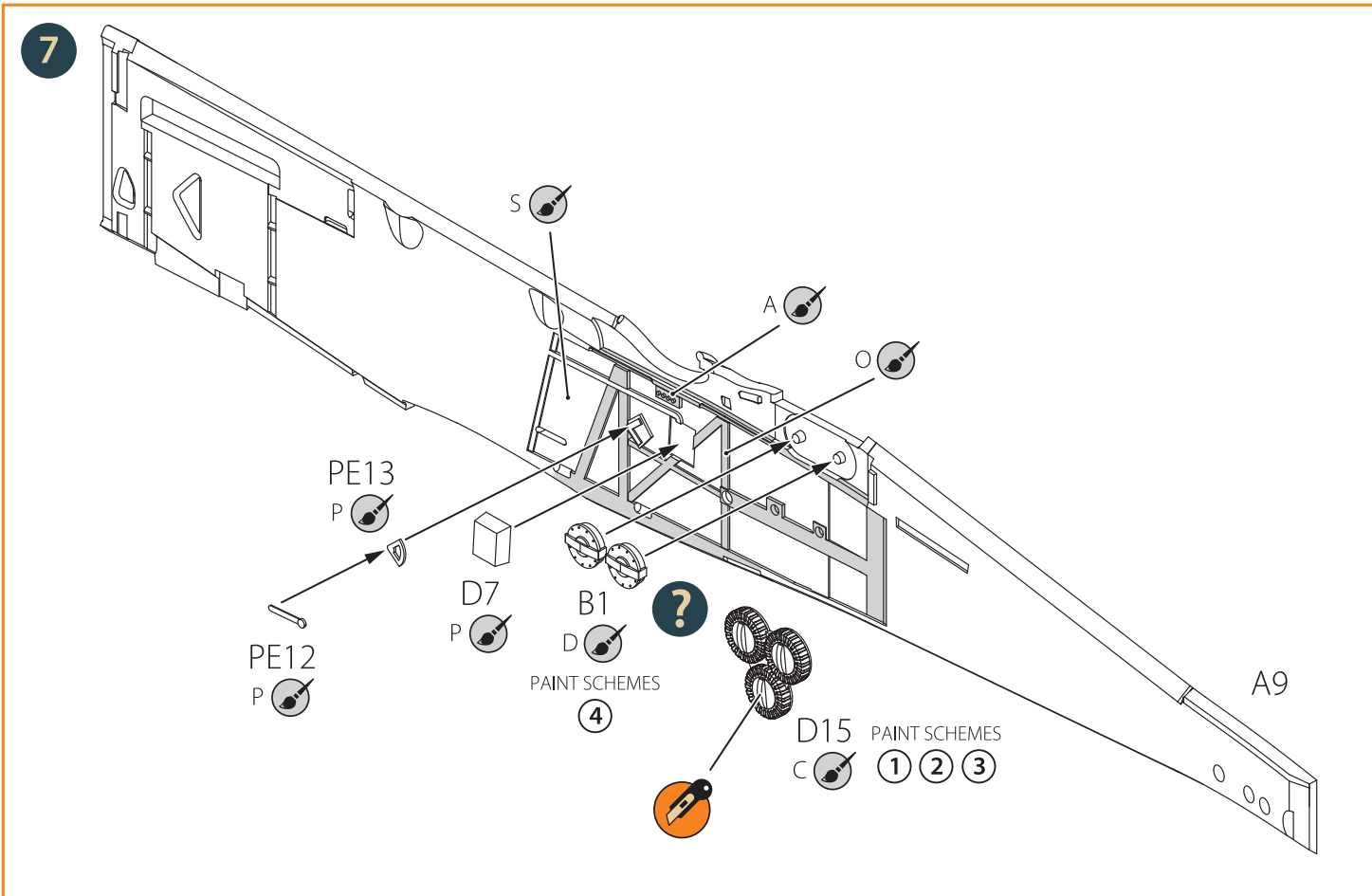

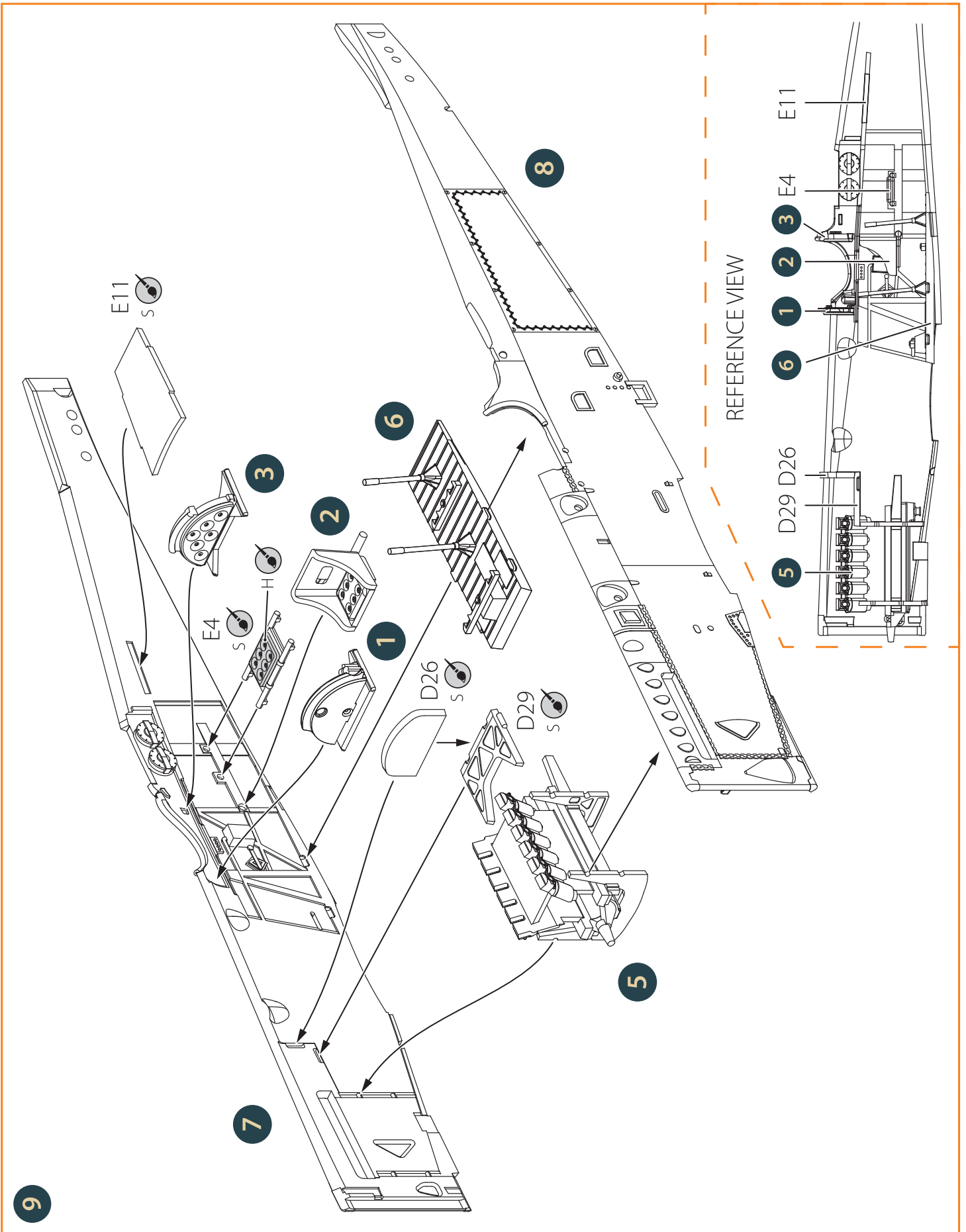

10

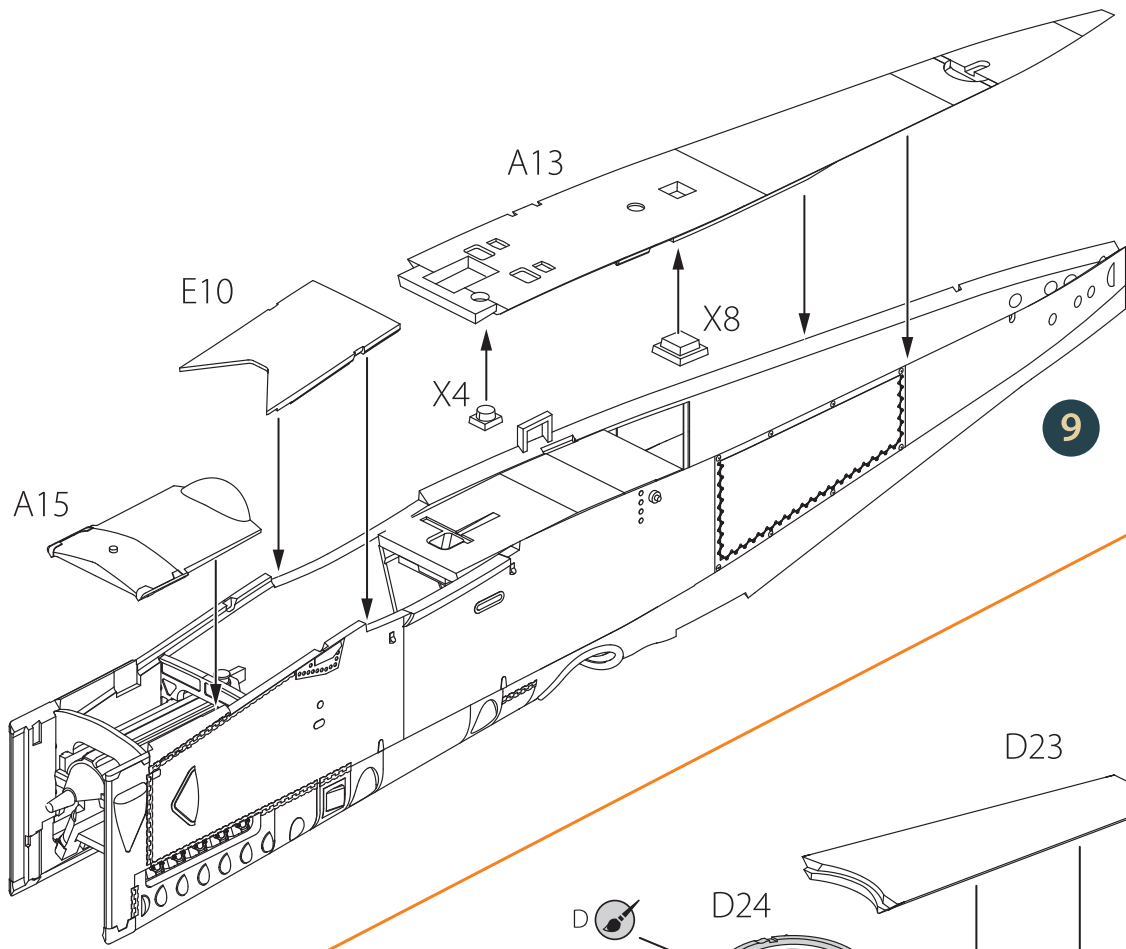

11

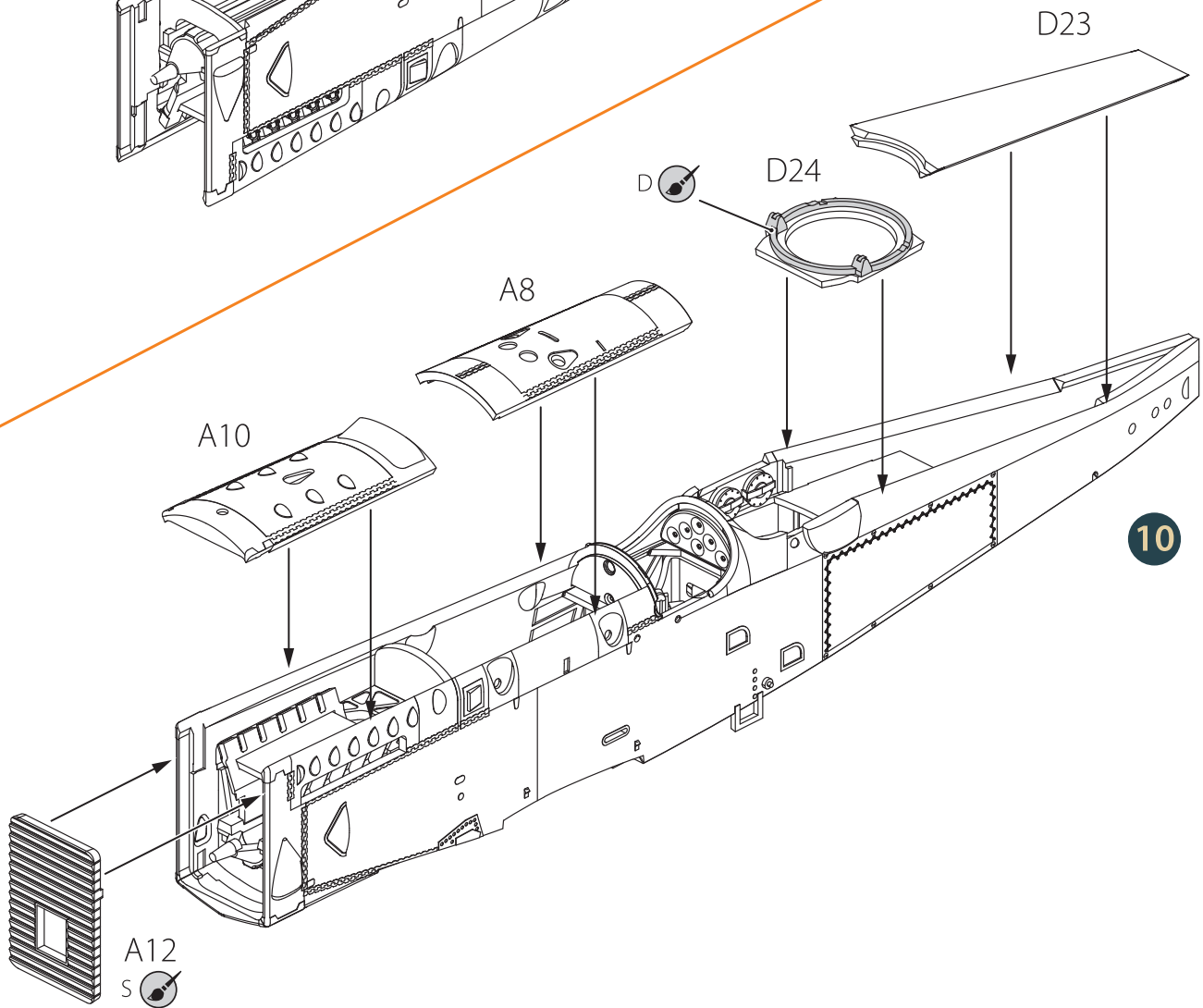

12

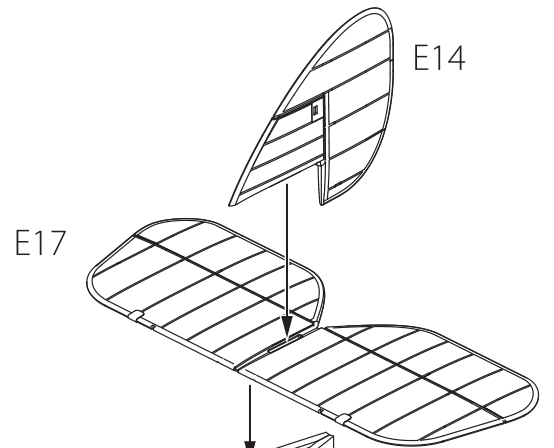

13

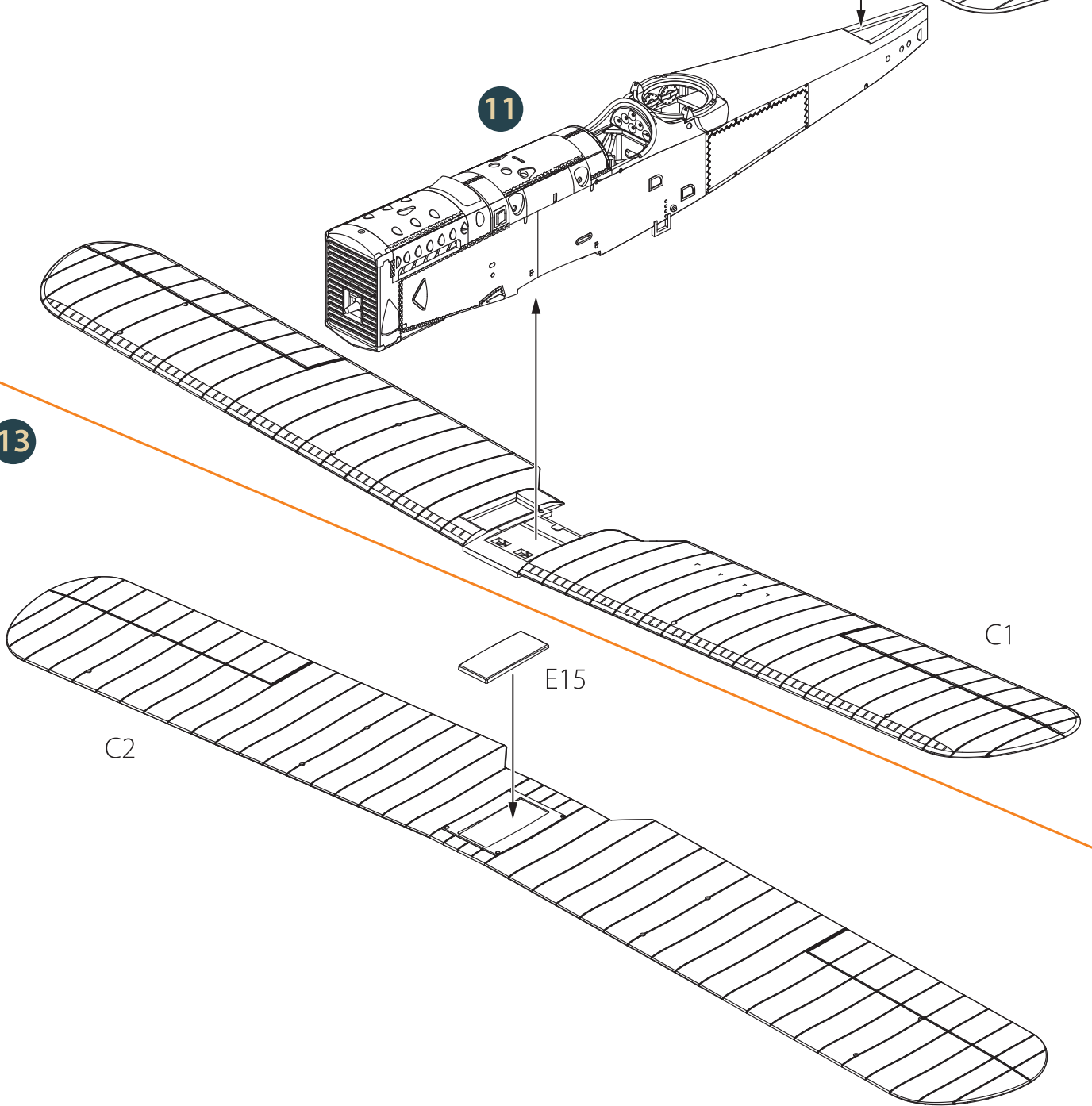

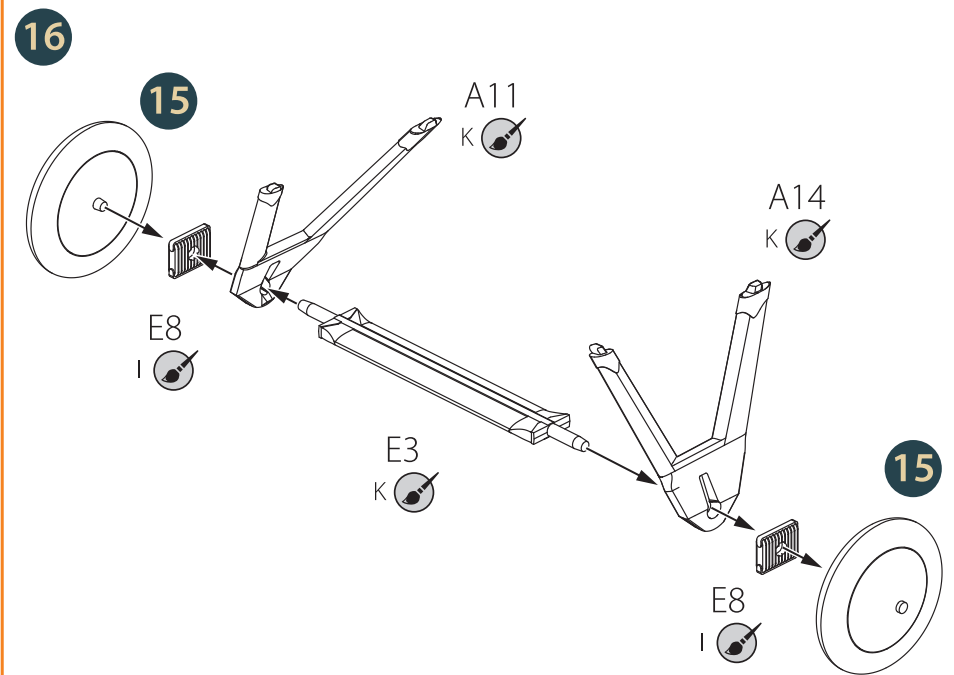
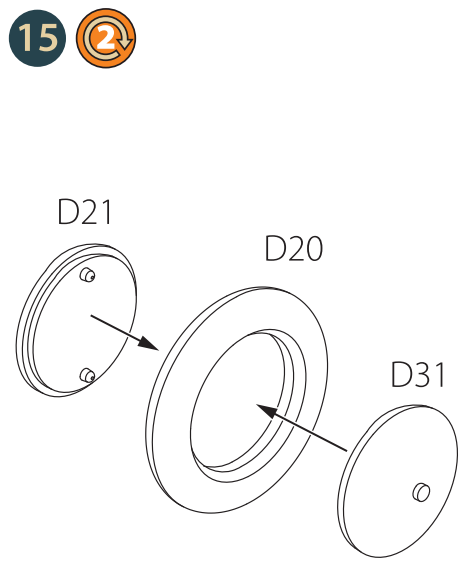
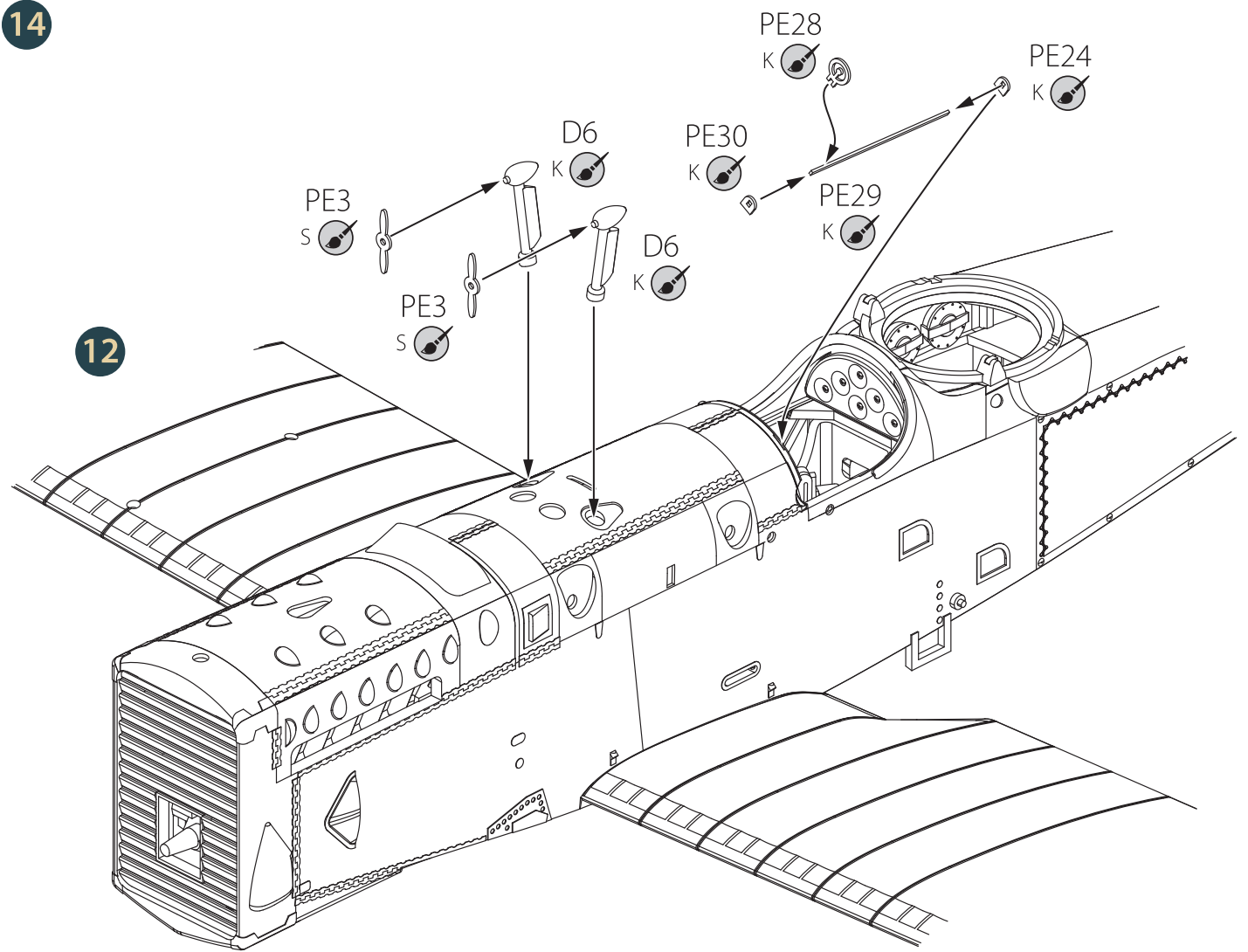

17

13

14

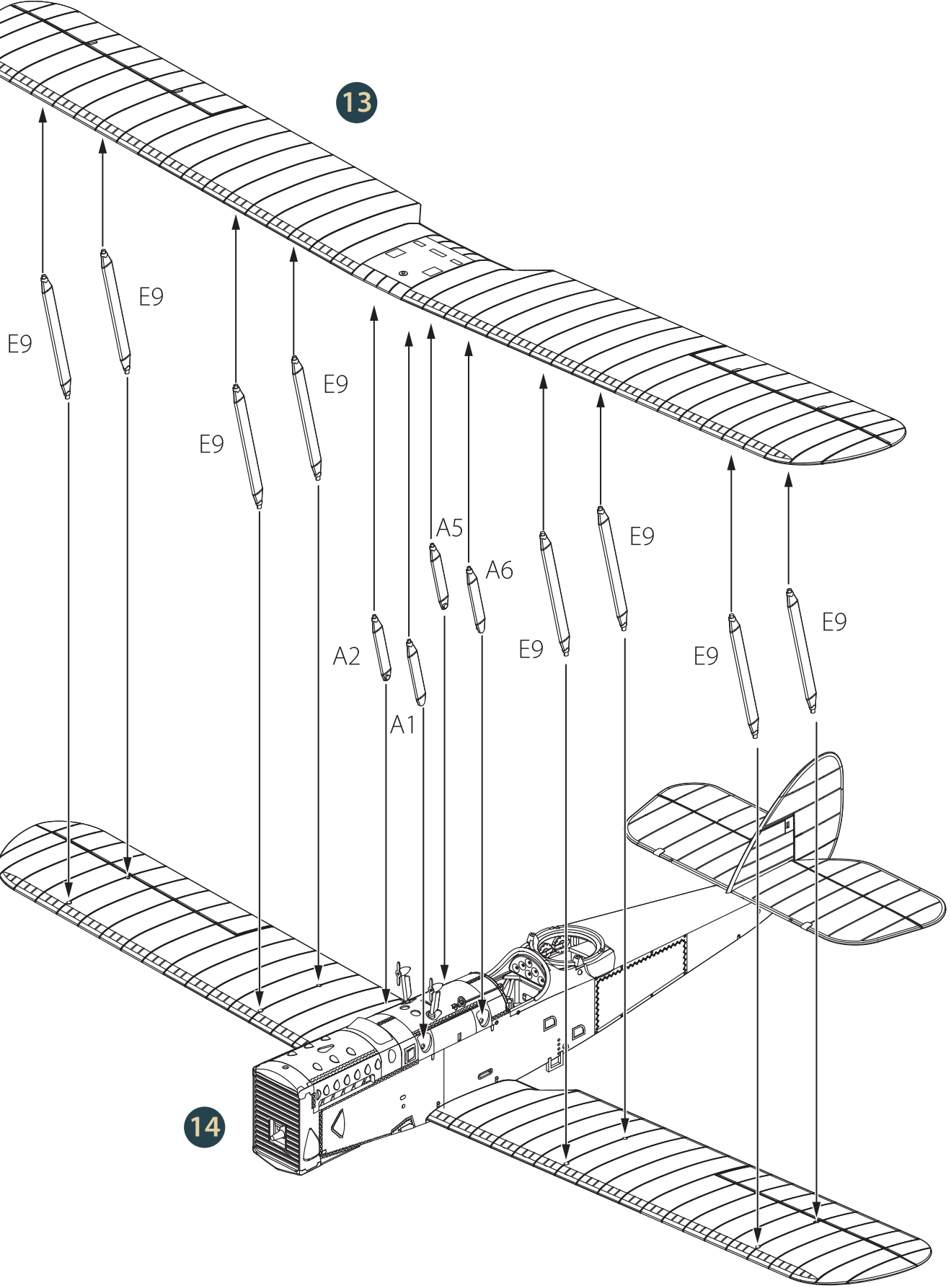

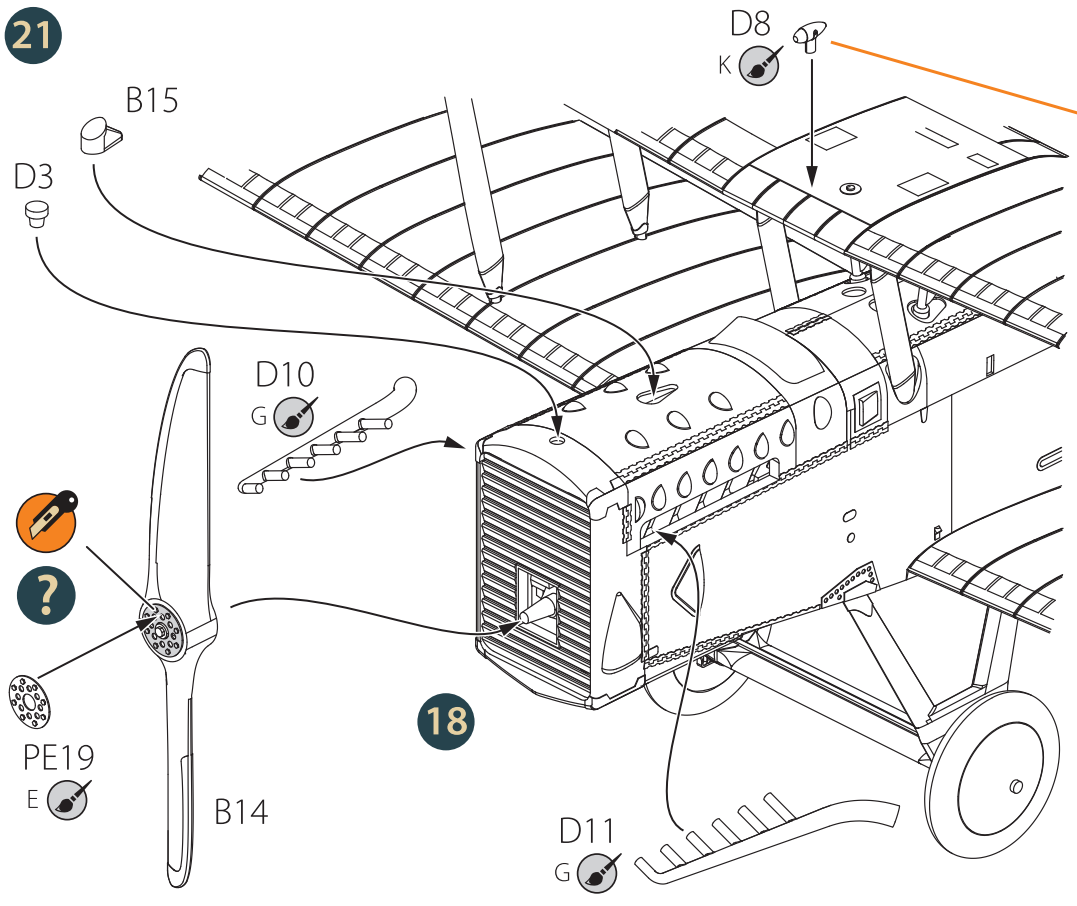
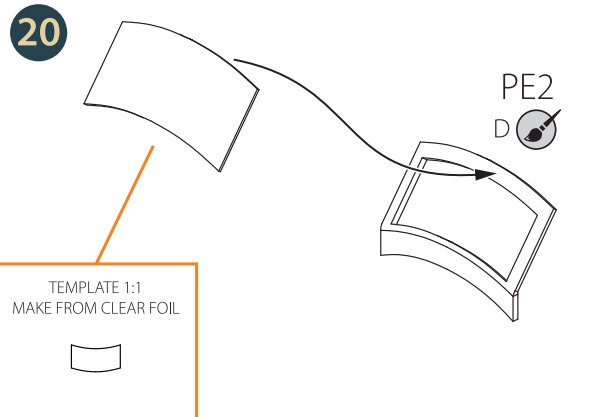
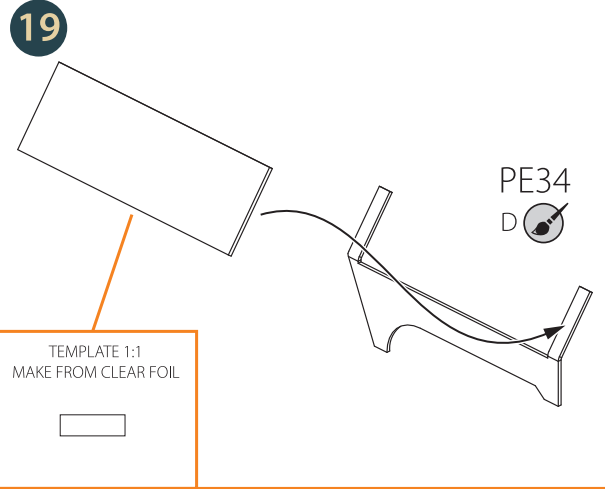
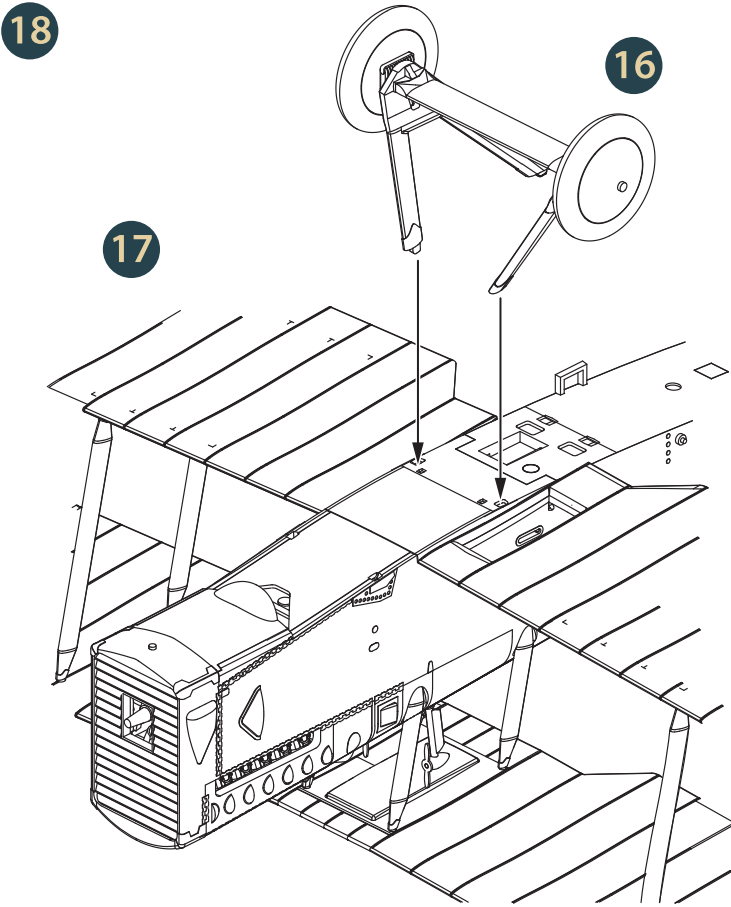

CORRECT POSITION OF NAVIGATION LIGHT

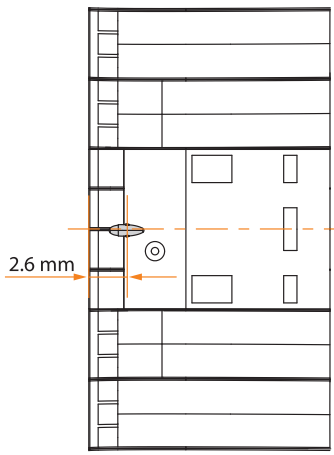

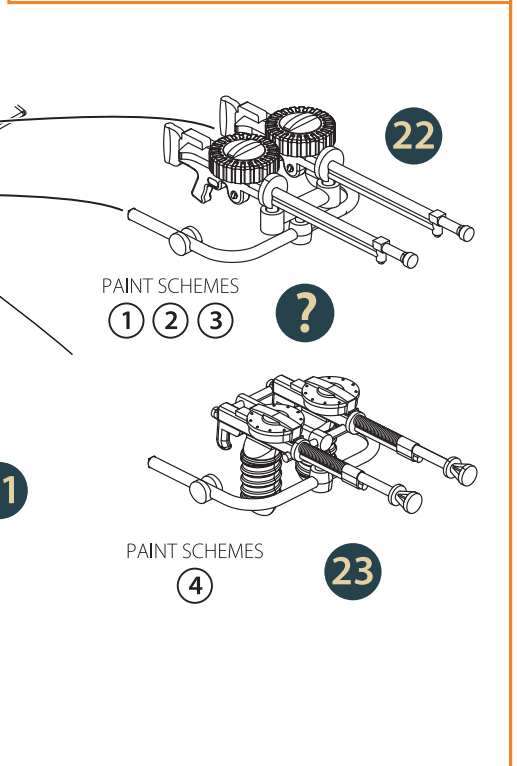
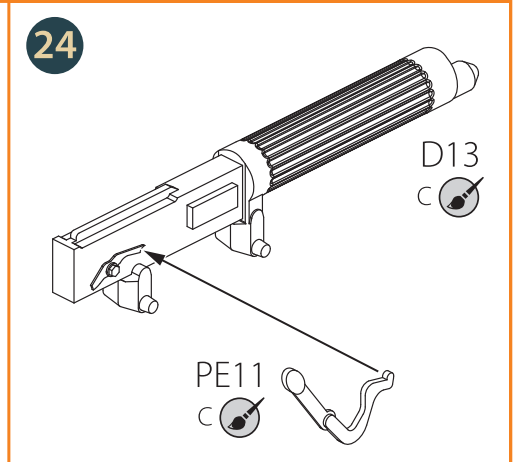
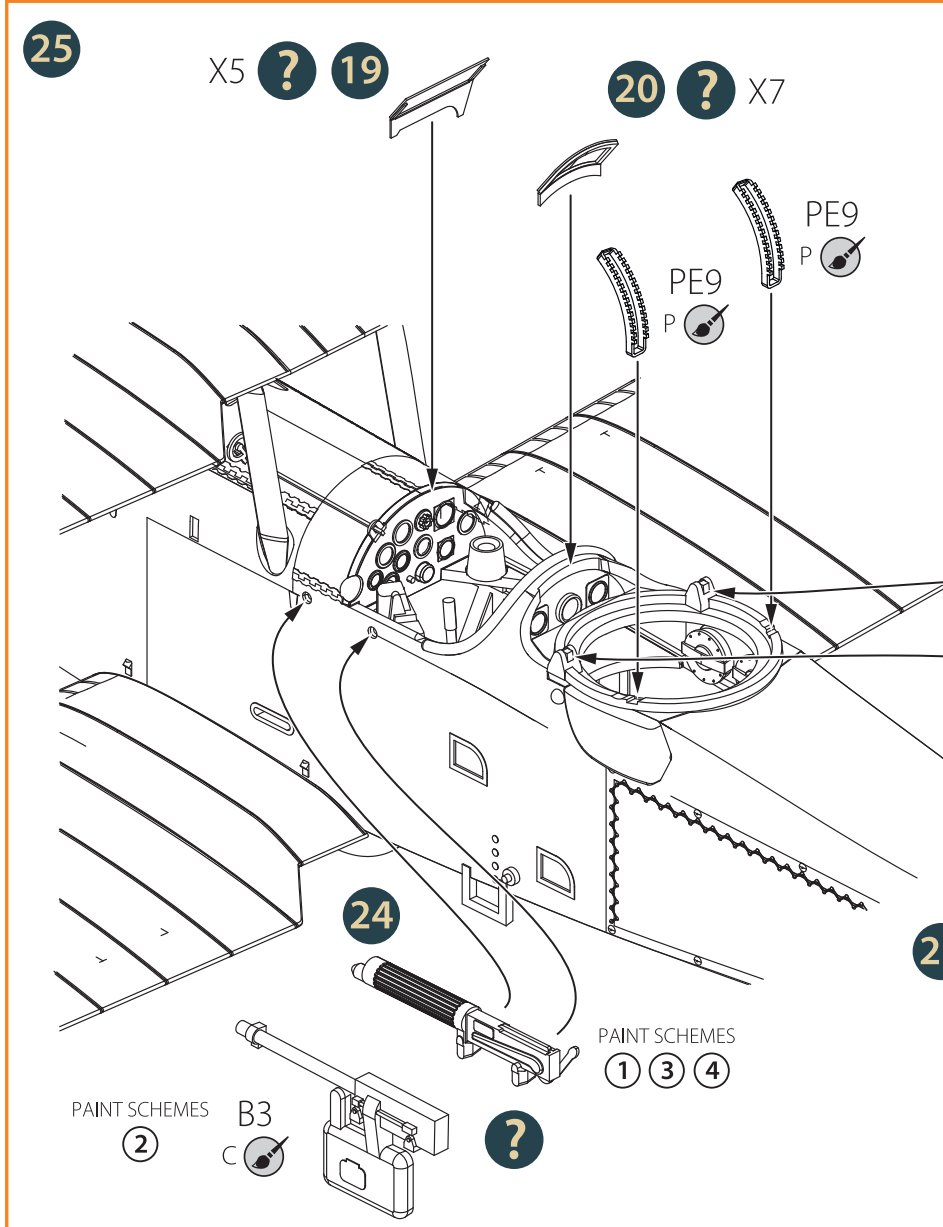
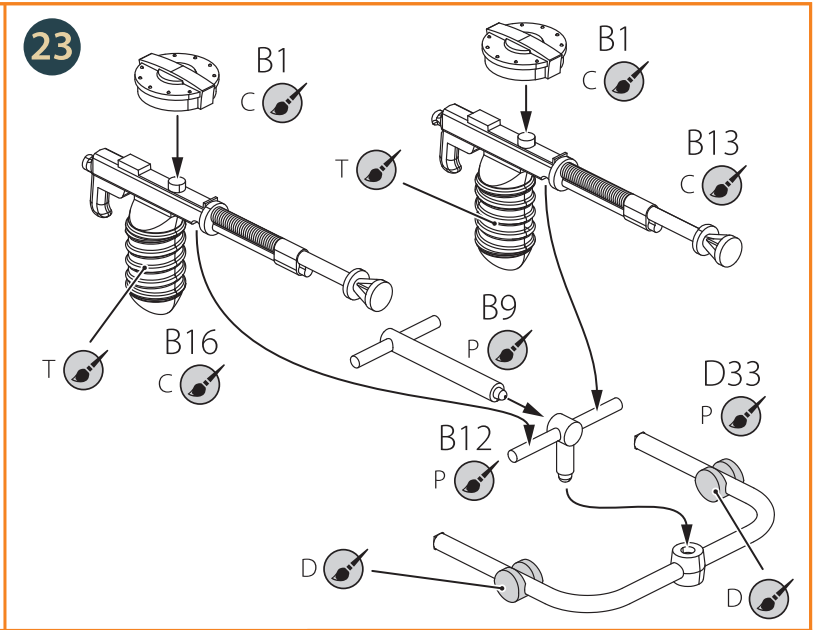
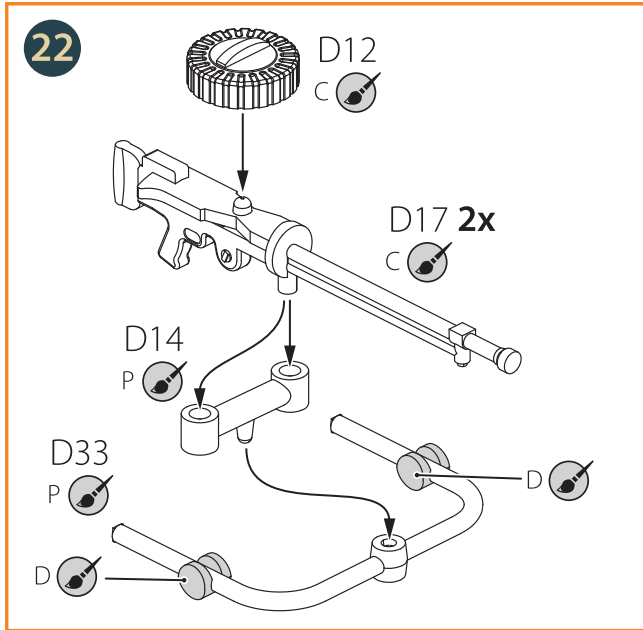

26

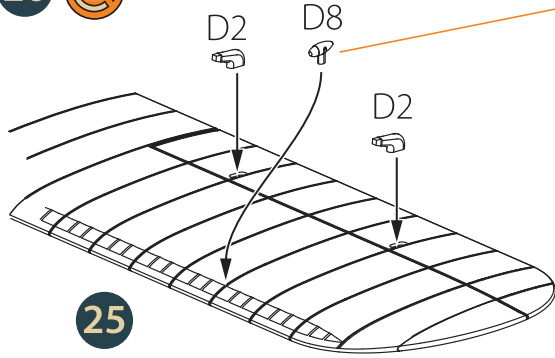

CORRECT POSITION OF NAVIGATION LIGHT

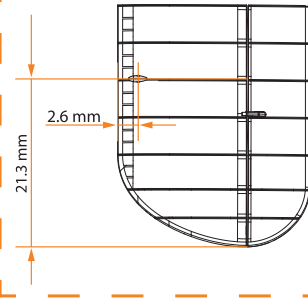

27

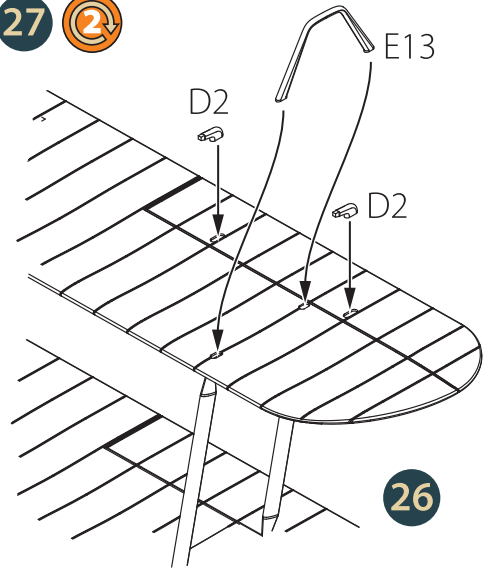

28

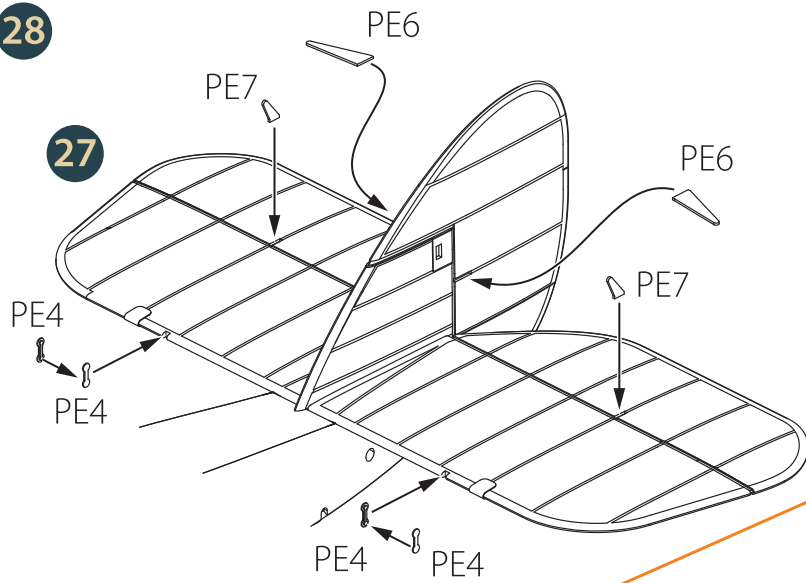

29

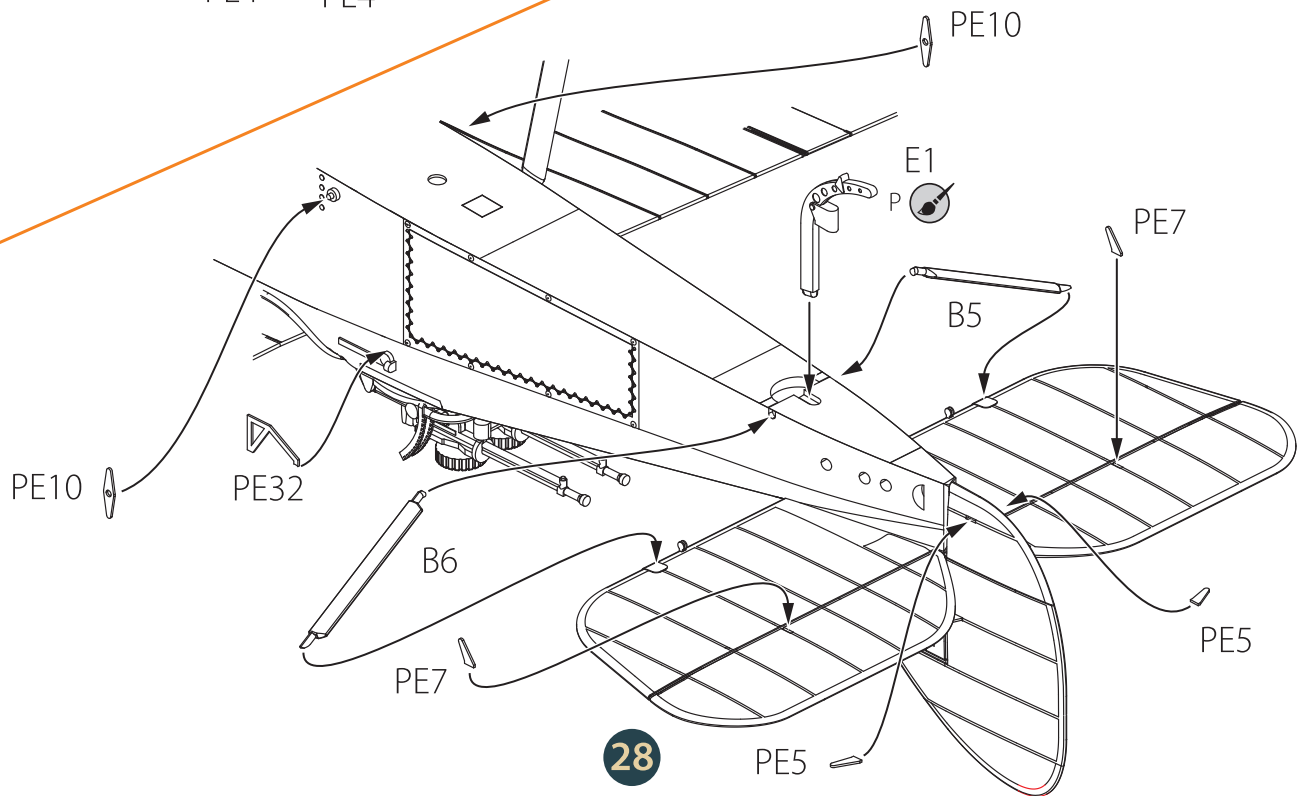

32

29

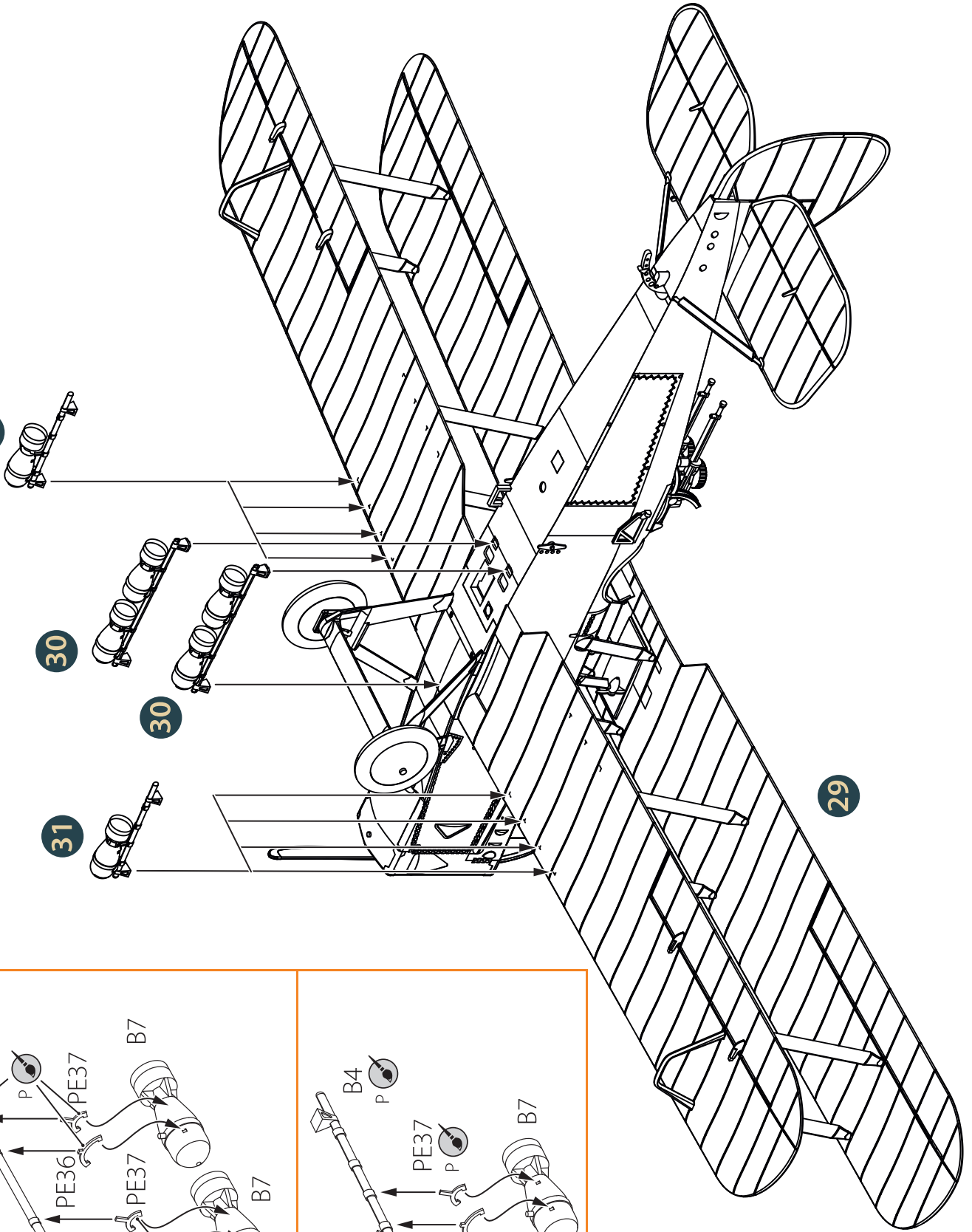

30 2

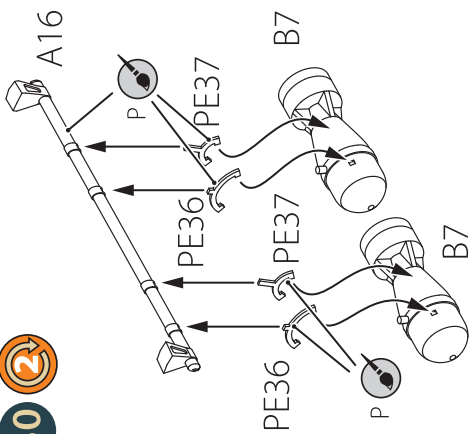

31 8

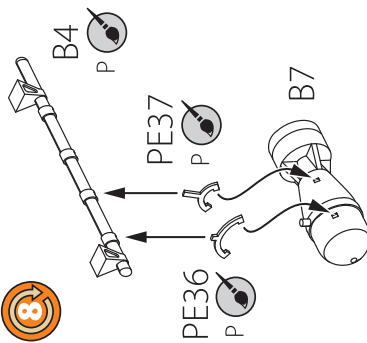

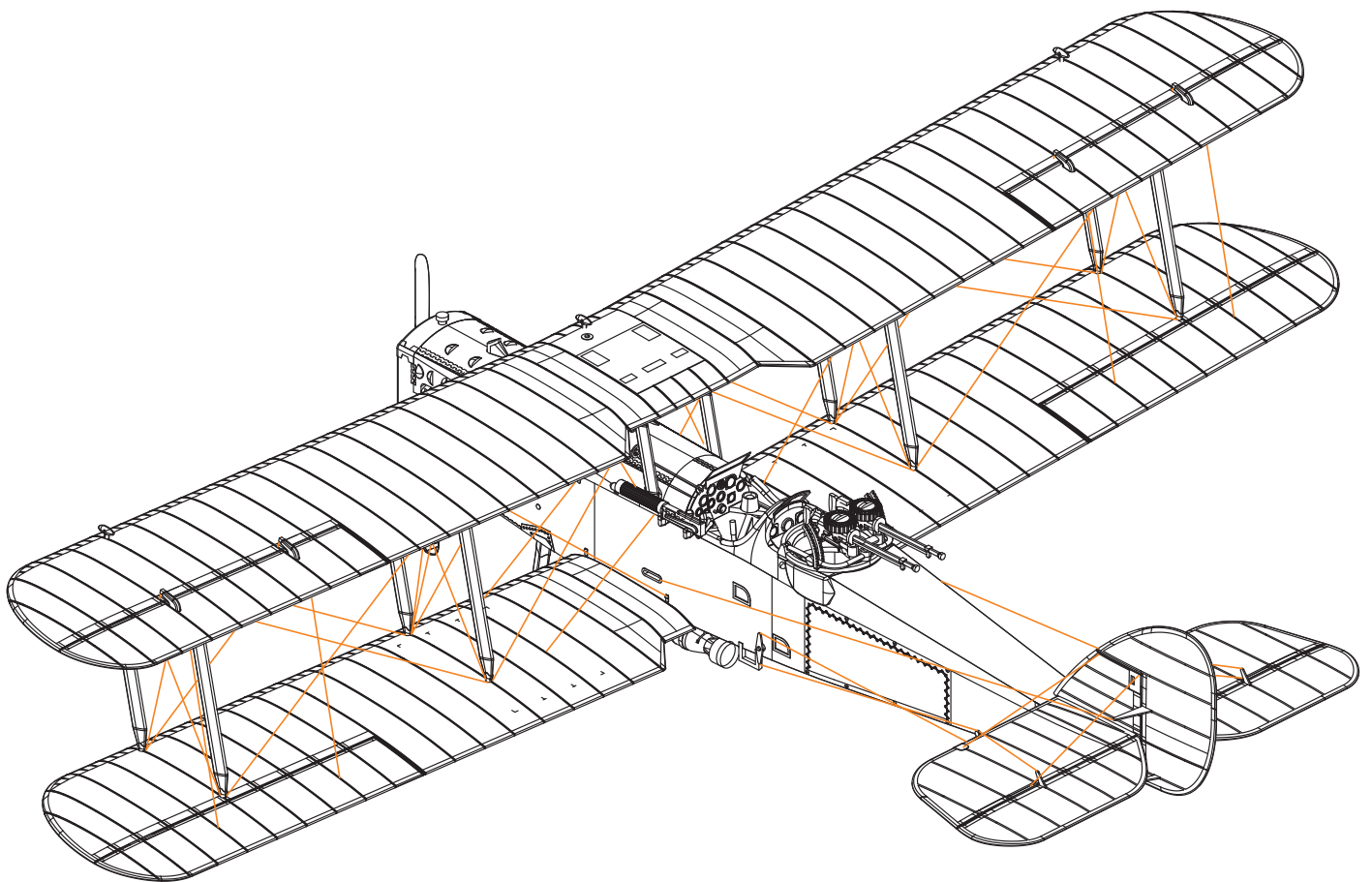
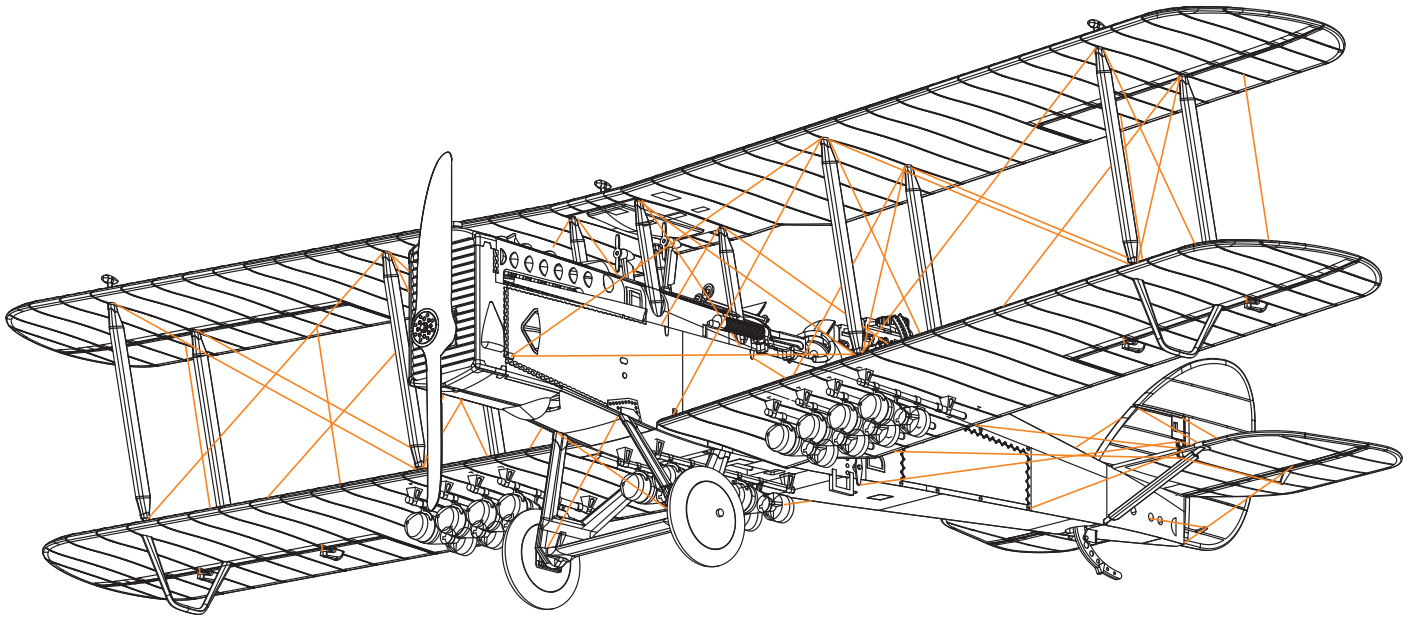

- | | | | | | | | | | |
|---------------------|-------------------------|--------------------------------------|-----------------------|------------------------------------|------------------------------|-------------------------------|---------------------------|----------------------|--------------------------|
| A | D | F | H | J | K | M | P | R | S |
| A.MIG-0197
BRASS | A.MIG-0194
ALUMINIUM | A.MIG-0204
MEDIUM
GUNSHIP GREY | A.MIG-0133
LEATHER | A.MIG-024
AllgLIGHT
GRAY BLU | A.MIG-0031
KHAKI
GREEN | A.MIG-0054
SIGNAL
GREEN | A.MIG-0032
SATIN BLACK | A.MIG-0033
RUBBER | A.MIG-0038
LIGHT WOOD |

① R-1 "Krasny Suchanets" from the 19th Independent Aviation Unit of the Red Army Air Force named "Far Eastern Ultimatum", Soviet-Chinese conflict, Chinese Eastern Railway (CER) October-November 1929

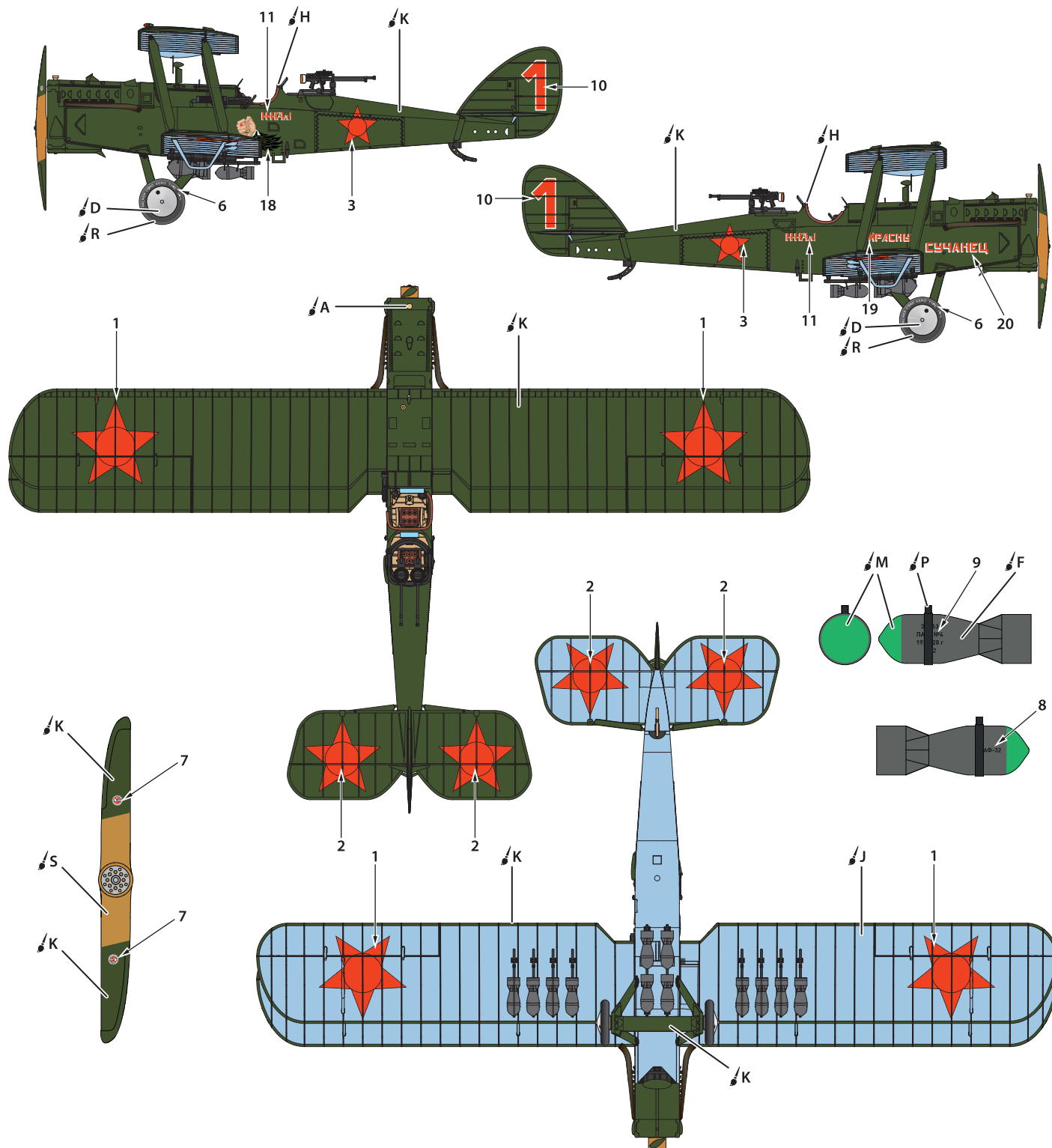



- | | | | | | | | | | |
|---------------------|-------------------------|--------------------------------------|-----------------------|------------------------------------|------------------------------|-------------------------------|---------------------------|----------------------|--------------------------|
| A | D | F | H | J | K | M | P | R | S |
| A.MIG-0197
BRASS | A.MIG-0194
ALUMINIUM | A.MIG-0204
MEDIUM
GUNSHIP GREY | A.MIG-0133
LEATHER | A.MIG-024
AllgLIGHT
GRAY BLU | A.MIG-0031
KHAKI
GREEN | A.MIG-0054
SIGNAL
GREEN | A.MIG-0032
SATIN BLACK | A.MIG-0033
RUBBER | A.MIG-0038
LIGHT WOOD |

② R-1 "Imeni Kingiseppa" built with the money of workers from Leningrad and workers from USSR's Estonia, Red Army Air Force squadron "Our answer to Chamberlain", Moscow, 1928

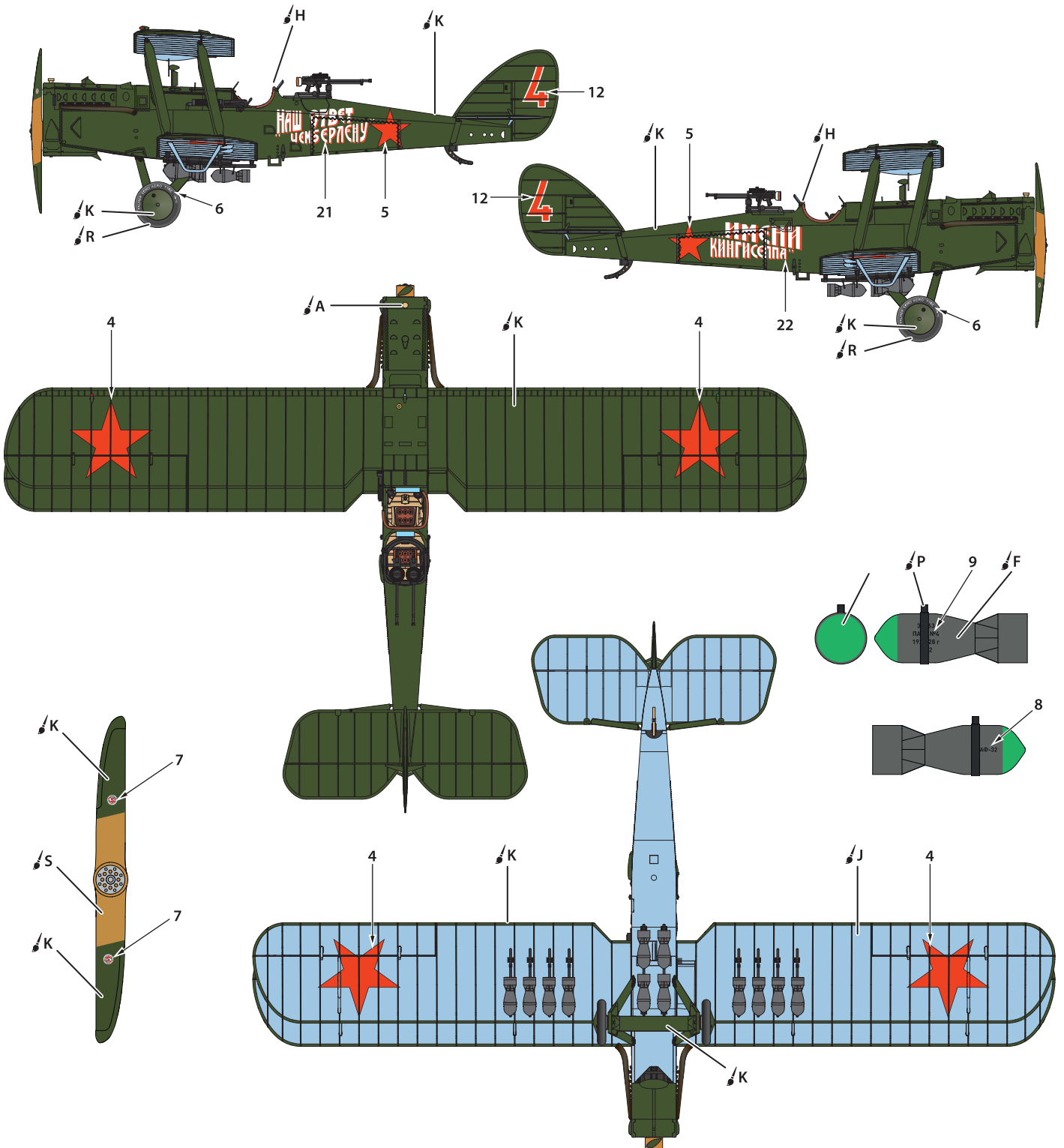



- | | | | | | | | | | |
|---------------------|-------------------------|--------------------------------------|-----------------------|------------------------------------|------------------------------|-------------------------------|---------------------------|----------------------|--------------------------|
| A | D | F | H | J | K | M | P | R | S |
| A.MIG-0197
BRASS | A.MIG-0194
ALUMINIUM | A.MIG-0204
MEDIUM
GUNSHIP GREY | A.MIG-0133
LEATHER | A.MIG-024
AllgLIGHT
GRAY BLU | A.MIG-0031
KHAKI
GREEN | A.MIG-0054
SIGNAL
GREEN | A.MIG-0032
SATIN BLACK | A.MIG-0033
RUBBER | A.MIG-0038
LIGHT WOOD |

③ R-1 "Chernigovets" from the Red Army Air Force 5th reconnaissance squadron, pilot Lee Dia-muk, Kharkiv, 1925

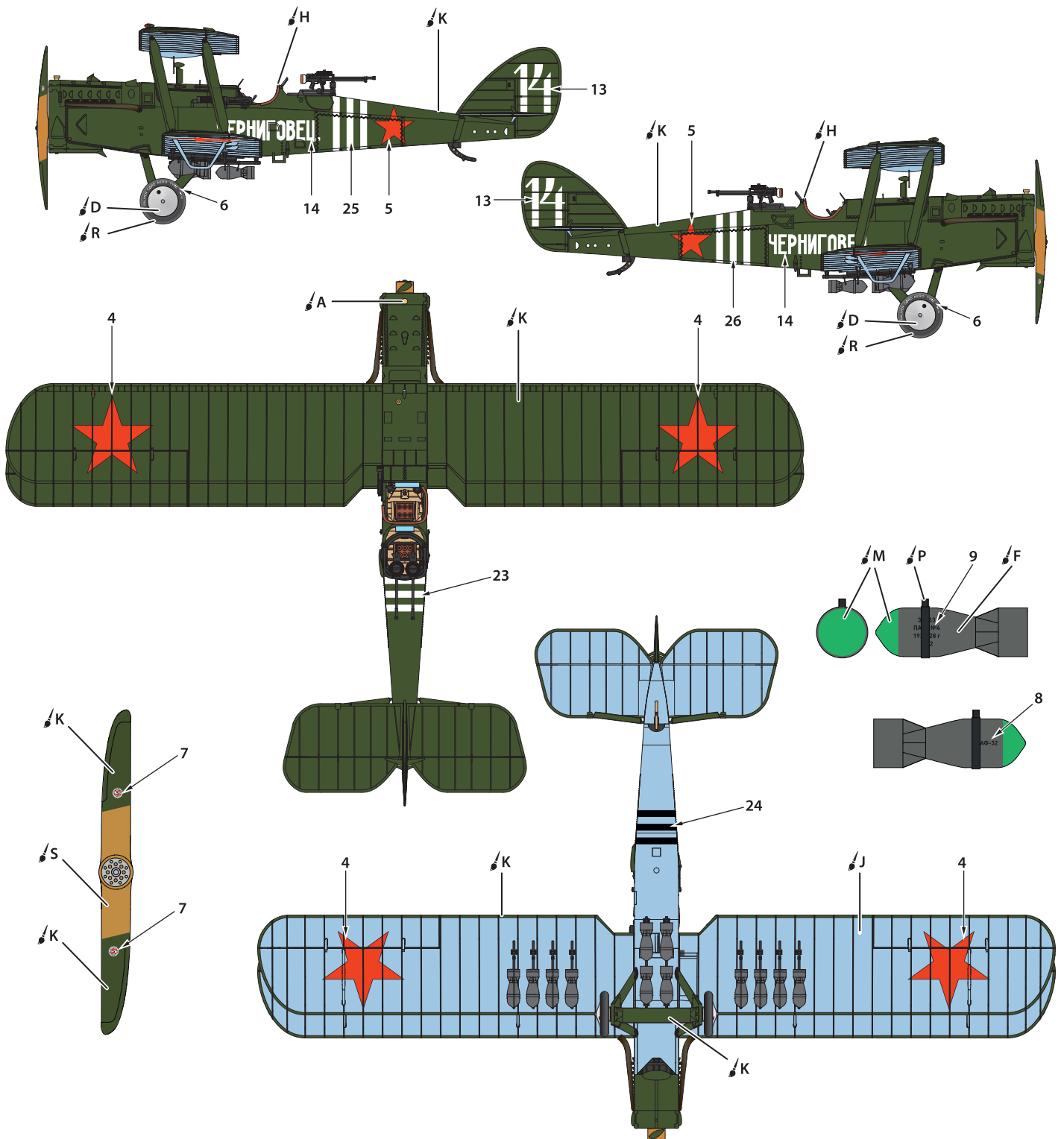



VISIT OUR SITE FOR MORE SCALE MODEL KITS

clearpropmodels.com



sales@clearpropmodels.com



www.fb.com/Clearpropmodels